

Pioneering for You

**wilo**

## **Wilo-Rexa FIT**



**en** Installation and operating instructions



## Table of contents

<b>1</b>	<b>General information .....</b>	<b>5</b>
1.1	About these instructions .....	5
1.2	Copyright .....	5
1.3	Subject to change .....	5
1.4	Warranty .....	5
<b>2</b>	<b>Safety .....</b>	<b>5</b>
2.1	Identification of safety instructions.....	5
2.2	Personnel qualifications.....	6
2.3	Electrical work .....	6
2.4	Monitoring devices .....	7
2.5	Use in fluids hazardous to health .....	7
2.6	Transport.....	7
2.7	Installing/dismantling.....	7
2.8	During operation .....	7
2.9	Maintenance tasks .....	8
2.10	Operating fluid .....	8
2.11	Operator responsibilities.....	8
<b>3</b>	<b>Application/use .....</b>	<b>8</b>
3.1	Intended use .....	8
3.2	Improper use.....	9
<b>4</b>	<b>Product description .....</b>	<b>9</b>
4.1	Design .....	9
4.2	Monitoring devices .....	10
4.3	Operating modes.....	10
4.4	Operation with frequency converter.....	10
4.5	Operation in an explosive atmosphere .....	10
4.6	Technical data .....	10
4.7	Type key .....	10
4.8	Scope of delivery.....	11
4.9	Accessories .....	11
<b>5</b>	<b>Transportation and storage .....</b>	<b>11</b>
5.1	Delivery.....	11
5.2	Transport.....	11
5.3	Storage .....	12
<b>6</b>	<b>Installation and electrical connection .....</b>	<b>12</b>
6.1	Personnel qualifications.....	12
6.2	Installation types.....	13
6.3	Operator responsibilities.....	13
6.4	Installation .....	13
6.5	Electrical connection .....	17
<b>7</b>	<b>Commissioning.....</b>	<b>19</b>
7.1	Personnel qualifications.....	19

7.2	Operator responsibilities.....	19
7.3	Direction of rotation check (for three-phase current motors only).....	19
7.4	Before switching on.....	20
7.5	Switch on and off.....	20
7.6	During operation.....	20
<b>8</b>	<b>Decommissioning/dismantling.....</b>	<b>21</b>
8.1	Personnel qualifications.....	21
8.2	Operator responsibilities.....	21
8.3	Decommissioning.....	21
8.4	Removal.....	21
<b>9</b>	<b>Maintenance and repair.....</b>	<b>23</b>
9.1	Personnel qualifications.....	23
9.2	Operator responsibilities.....	23
9.3	Operating fluid.....	23
9.4	Maintenance intervals.....	23
9.5	Maintenance measures.....	24
<b>10</b>	<b>Faults, causes and remedies.....</b>	<b>25</b>
<b>11</b>	<b>Spare parts.....</b>	<b>27</b>
<b>12</b>	<b>Disposal.....</b>	<b>27</b>
12.1	Oils and lubricants.....	27
12.2	Protective clothing.....	28
12.3	Information on the collection of used electrical and electronic products.....	28

## 1 General information

### 1.1 About these instructions

These installation and operating instructions are an integral part of the product. Read these instructions before commencing work and keep them in an accessible place at all times. Strict adherence to these instructions is a precondition for the intended use and correct operation of the product. All information and markings on the product must be observed.

The language of the original operating instructions is German. All other languages of these instructions are translations of the original operating instructions.

### 1.2 Copyright

These installation and operating instructions have been copyrighted by the manufacturer. Contents, of whatever type, which may not be reproduced or distributed, or used for purposes of competition and shared with others.

### 1.3 Subject to change

The manufacturer reserves the right to make technical modifications to the device or individual components. The illustrations used may differ from the original and are intended as an example representation of the device.

### 1.4 Warranty

The specifications in the current "General Terms and Conditions" apply to the warranty and the warranty period. These can be found at [www.wilo.com/legal](http://www.wilo.com/legal). Any deviations must be contractually agreed and shall then be given priority.

#### **Claim to warranty**

If the following points are complied with, the manufacturer is obligated to rectify every qualitative or constructive flaw:

- The defects are reported in writing to the manufacturer within the warranty period.
- Application according to intended use.
- All monitoring devices are connected and tested before commissioning.

#### **Exclusion from liability**

Exclusion from liability excludes all liability for personal injury, material damage or financial losses. This exclusion ensues as soon as one of the following applies:

- Inadequate configuration due to inadequate or incorrect instructions by the operator or the client

- Non-compliance with installation and operating instructions
- Improper use
- Incorrect storage or transport
- Incorrect installation or dismantling
- Insufficient maintenance
- Unauthorised repairs
- Inadequate construction site
- Chemical, electrical or electro-chemical influences
- Wear

## 2 Safety

This chapter contains basic information which must be adhered to during the individual phases of the life cycle. Failure to follow the installation and operating instructions will result in injuries to persons, damage to the environment and the device and result in the loss of any claims for damages. Failure to follow the instructions can result in the following risks:

- Danger to persons due to electrical, mechanical and bacteriological factors as well as electromagnetic fields
- Environmental risks due to leakage of hazardous substances
- Property damage
- Failure of important functions of the product

**Additionally, the instructions and safety instructions in the other chapters must be observed!**

### 2.1 Identification of safety instructions

These installation and operating instructions set out safety instructions for preventing personal injury and damage to property. These safety instructions are shown differently:

- Safety instructions relating to personal injury start with a signal word, are **preceded by a corresponding symbol** and are shaded in grey.



#### **DANGER**

##### **Type and source of the danger!**

Consequences of the danger and instructions for avoidance.

- Safety instructions for property damage start with a signal and are displayed **without** a symbol.

---

#### **CAUTION**

##### **Type and source of the danger!**

Consequences or information.

---

**Signal words**

- **DANGER!**  
Failure to observe the safety instructions will result in serious injuries or death!
- **WARNING!**  
Failure to follow the instructions can lead to (serious) injuries!
- **CAUTION!**  
Failure to follow the instructions can lead to property damage and a possible total loss.
- **NOTE!**  
Useful information on handling the product.

**Symbols**

These instructions use the following symbols:

-  Danger of electric voltage
-  Danger of bacterial infection
-  Danger of explosion
-  General warning symbols
-  Warning of crushing
-  Warning of cutting injuries
-  Warning of hot surfaces
-  Warning of high pressure
-  Warning of suspended loads
-  Personal protective equipment: Wear a safety helmet
-  Personal protective equipment: Wear foot protection
-  Personal protective equipment: Wear hand protection
-  Personal protective equipment: Wear mouth protection
-  Personal protective equipment: Wear safety goggles
-  Autonomous work prohibited! A second person must be present.
-  Useful information

**Markups**

- ✓ Prerequisite

- 1. Work step/list  
⇒ Information/instructions

► Result

**2.2 Personnel qualifications**

Personnel must:

- Be instructed in the locally applicable accident prevention regulations.
- Have read and understood the installation and operating instructions.  
Personnel must have the following qualifications:
- Electrical work: Electrical work must be carried out by a qualified electrician (in accordance with EN 50110-1).
- Installation-/dismantling: The technician must be trained in the use of the necessary tools and mounting materials for the relevant construction site.
- Maintenance tasks: The technician must be familiar with the use of operating fluids and their disposal. In addition, the technician must have basic knowledge of mechanical engineering.

**Definition of “qualified electrician”**

A qualified electrician is a person with appropriate technical education, knowledge and experience who can identify **and** prevent electrical hazards.

**2.3 Electrical work**

- A qualified electrician must carry out the electrical work.
- When connecting to the mains, comply with the locally applicable laws and regulations of the local energy supply company.
- Before commencing work, disconnect the device from the mains and secure it against being switched on again without authorisation.
- Personnel is trained on the execution of the electrical connection and the options for switching off the device.
- Comply with the technical specifications contained in these installation and operating instructions and on the rating plate.
- Earth the device.
- Observe the manufacturer’s specifications when connecting to electrical switching systems.
- Comply with the specifications on electro-magnetic compatibility when connecting electronic start-up controllers (e.g. soft starter or frequency converter). If required, take into account special measures (e.g. shielded cables, filters etc.).

- Replace defective power supply cables immediately. Contact customer service.

## 2.4 Monitoring devices

The following monitoring equipment must be provided on-site:

### **Circuit breaker**

The size of the circuit breakers conforms to the rated current of the pump. The switching characteristics should comply with group B or C. Observe local regulations.

### **Motor protection switch**

Make provision for an on-site motor protection switch for devices without a plug! The minimum requirement is a thermal relay/motor protection switch with temperature compensation, differential triggering and anti-reactivation device in accordance with the local regulations. In case of sensitive mains, make provision for the installation on-site of other protective equipment (e.g. overvoltage, undervoltage or phase failure relay, etc.).

### **Residual-current device (RCD)**

Comply with the regulations of the local energy supply company! The use of a residual-current device is recommended.

If persons come into contact with the device and conductive fluids, secure the connection **with** a residual-current device (RCD).

## 2.5 Use in fluids hazardous to health

There is a danger of bacterial infection when using the device in fluids hazardous to health! Thoroughly clean and disinfect the device after dismantling and prior to further use. The operator must ensure the following:

- The following protective equipment is provided and worn when cleaning the device:
  - Closed safety goggles
  - Breathing mask
  - Protective gloves
- All persons are informed about the fluid, the associated danger and its correct handling!

## 2.6 Transport

- The following protective equipment must be worn:
  - Safety shoes
  - Safety helmet (when using lifting equipment)
- Always hold the handle to transport the device. Never pull the power supply cable!
- Only use legally specified and approved lifting gear.

- Select the lifting gear based on the available conditions (weather, attachment point, load, etc.).
- Always attach the lifting gear to the attachment points (handle or lifting eyelet).
- The stability of the lifting equipment must be ensured during operation.
- When using lifting equipment, a second person must be present to coordinate the procedure if required (e.g. if the operator's field of vision is blocked).
- Persons are not permitted to stand beneath suspended loads. Do **not** lift loads above workplaces, on which people are present.

## 2.7 Installing/dismantling

- Wear the following protective equipment:
  - Safety shoes
  - Safety gloves against cuts
  - Safety helmet (when using lifting equipment)
- Locally applicable laws and regulations for work safety and accident prevention must be complied with.
- Disconnect the device from the mains and secure it against being switched on again without authorisation.
- All rotating parts must be at a standstill.
- Provide adequate aeration in closed rooms.
- When working in chambers and closed spaces, a second person must be present for safety reasons.
- Take immediate countermeasures if there is a build-up of toxic or suffocating gases!
- Clean the device thoroughly. Disinfect devices that are used in fluids hazardous to health!
- Make sure that there is no risk of explosion when carrying out any type of welding work or work with electrical devices.

## 2.8 During operation

- Wear the following protective equipment:
  - Safety shoes
  - Ear protection (in accordance with the notice of the work regulations)
- Work area of the device is not a recreational area. No persons are allowed in the work area during operation.
- The operator must immediately report any faults or irregularities to their line manager.
- If safety-endangering defects occur, the operator must immediately deactivate the device:
  - Malfunction of the safety and monitoring equipment
  - Damage to the housing parts
  - Damage to the electrical equipment
- Never reach into the suction port. The rotating parts can crush and sever limbs.

- If the motor emerges during operation, the motor housing can reach temperatures in excess of 40 °C.
- Open all gate valves in the piping on the suction and pressure side.
- Ensure minimum water submersion through dry-running protection.
- Under normal operating conditions, the sound pressure level of the device is below 85 dB(A). However, the actual sound-pressure level depends on several factors:
  - Installation depth
  - Installation
  - Fixation of accessories and pipe
  - Duty point
  - Immersion depth
- If the device is operated under normal operating conditions, the operator must measure the sound pressure. Ear protection must be worn for sound pressure level of 85 dB(A) and above and this must be noted in the work regulations!

## 2.9 Maintenance tasks

- Wear the following protective equipment:
  - Closed safety goggles
  - Safety shoes
  - Safety gloves against cuts
- Always carry out maintenance tasks outside the operating space/installation site.
- Only carry out maintenance tasks mentioned in this installation and operating instructions.
- Only original parts from the manufacturer may be used for maintenance and repairs. Use of parts other than the original parts releases the manufacturer from any liability.
- Collect any leakage of fluid and operating fluid immediately and dispose of it according to the locally applicable guidelines.
- Store tools at the designated locations.
- After completing work, reattach all safety and monitoring devices and check that they function properly.

### **Changing operating fluid**

In case of a defect, a pressure **of several bar can build up** in the motor! This pressure escapes when the screw plugs are **opened**. If screw plugs are opened without due caution, they can be ejected at high speed! To avoid injuries, observe the following instructions:

- Adhere to the prescribed sequence of work steps.
- Unscrew the screw plugs slowly, but never unscrew them completely. As soon as the pressure escapes

(audible whistling or hissing of air), stop turning the screw plug any further.

**WARNING! Hot operating fluid can also spray out when the pressure is escaping. This can result in scalding! To avoid injuries, allow the motor to cool down to the ambient temperature before carrying out any work!**

- When the pressure has completely dissipated, fully unscrew the screw plug.

## 2.10 Operating fluid

In the sealing chamber, the motor is filled with white oil. Operating fluid must be replaced during regular maintenance work and disposed off according to the local guidelines.

## 2.11 Operator responsibilities

- Installation and operating instructions must be in a language which the personnel can understand.
- Make sure that the personnel is relevantly trained for the specified work.
- Provide the necessary protective equipment and make sure that the personnel wears it.
- Safety and information signs mounted on the device must be always legible.
- Train the personnel pertaining to the functioning of the system.
- Eliminate risk from electrical current.
- Equip hazardous components inside the system with an on-site guard.
- Identify and cordon off the work area.
- To ensure safe working practice, define the responsibilities of the employees.

Children and persons below 16 years or with reduced physical, sensory or mental capacities or limited experience are prohibited from handling the device! A technician must supervise persons below 18 years!

# 3 Application/use

## 3.1 Intended use

Submersible pumps are suitable for pumping:

- Sewage containing faeces (in accordance with EN 12050-1)
- Wastewater (with small amounts of sand and gravel)
- Fluids with dry matter up to max. 8 %



### 3.2 Improper use



#### DANGER

#### Explosion due to pumping of explosive fluids!

Pumping of highly flammable and explosive fluids (gasoline, kerosene, etc.) in pure form is strictly prohibited. There is a risk of fatal injury due to explosion! The pumps are not designed for these fluids.



#### DANGER

#### Danger due to fluids hazardous to health!

If the pump is used in fluids hazardous to health, decontaminate the pump after dismantling and before carrying out any other work! There is danger to life! Observe the specifications in the work regulations! The operator must make sure that the personnel has received and read the work regulations!

The submersible pumps must **not be used** for pumping:

- Drinking water
- Fluids containing hard components (such as stones, wood, metal, etc.)
- Fluids containing large quantities of abrasive contents (e.g. sand, gravel)

Intended use also includes compliance with this manual. Any other use is regarded as non-compliant with the intended use.

## 4 Product description

### 4.1 Design

Submersible sewage pump as a submersible monobloc unit for intermittent operation for wet well installation.

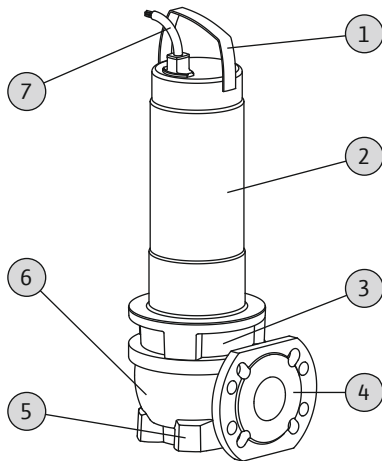

Fig. 1: Overview

1	Handle/attachment point
---	-------------------------

2	Motor
3	Seal housing
4	Pressure port
5	Suction port
6	Hydraulics housing
7	Power supply cable

#### 4.1.1 Hydraulics

Rotodynamic hydraulics with vortex impeller and horizontal flange connection on the pressure side  
The hydraulics is **not** self-priming, i.e. the fluid must flow in either automatically or with supply pressure.

#### 4.1.2 Motor

The drive versions used are single-phase current and three-phase current surface-cooled motors. The motor is cooled by the fluid around it. The waste heat is transferred directly to the fluid via the motor housing. The motor may emerge during operation.

With single-phase AC motors, the operating capacitor is integrated in the motor. The connection cable is available in the following versions:

- **Single-phase version:**
  - With shockproof plug
  - With a shockproof plug and fitted with a float switch
- **Three-phase version:**
  - With bare cable end
  - With CEE plug and fitted with a float switch

#### 4.1.3 Seal

The seal for the fluid and the motor compartment is made via two mechanical seals. The sealing chamber between the mechanical seals is filled with medical white oil.

#### 4.1.4 Material

- Pump housing: EN-GJL-250
- Impeller: EN-GJL-250
- Motor housing: 1.4301
- Shaft: 1.4021
- Seal on the motor side: C/MgSiO<sub>4</sub>
- Seal on the fluid side: SiC/SiC
- Seal, static: NBR

#### 4.1.5 Fitted accessories

##### Float switch

In the "A" version the pump is equipped with a float switch. Depending on the fill level, it is possible to switch the pump on and off automatically, by using the float switch.

### Plug

In the “P” and “A” version, a shockproof plug is attached for single-phase AC motors and a CEE plug is attached for three-phase motors. The plug is designed for use in commercially available shock-proof or CEE sockets and is **not** overflow-proof.

## 4.2 Monitoring devices

### Monitoring of motor winding

The thermal motor monitoring protects the motor winding from overheating. Temperature limiting with bimetallic strip is fitted as standard.

Thermal motor monitoring is self-switching for single-phase current motors. I.e. if the motor is switched off due to overheating and then cools down, it is automatically switched on again.

For three-phase current motors, the thermal motor monitoring must be connected in the switchgear or plug.

### Sealing chamber monitoring

The sealing chamber can be equipped with an external pencil electrode. The electrode registers fluid ingress through the m.seal on the fluid side. An alarm or deactivation of the pump can therefore take place through pump control.

## 4.3 Operating modes

### Operating mode S1: Continuous duty

The pump can operate continuously at the rated load without exceeding the permissible temperature.

### Operating mode S2: Short-time duty

The maximum operating period is specified in minutes, e.g. S2-15. The pause must last until the machine temperature no longer differs from the temperature of the coolant by more than 2 K.

### Operating mode S3: Intermittent periodic duty

This operating mode defines a switching cycle in a combination of periods of operation and standstill. Specified value (e.g. S3 25 %) relates to the operating time. The switching cycle has a duration of 10 min. If two values (e.g. S3 25 %/120 s) are specified, the first value relates to the operating time. The second value specifies the max. period of the switching cycle.

## 4.4 Operation with frequency converter

Operation on the frequency converter is not permitted.

## 4.5 Operation in an explosive atmosphere

Operation in an explosive atmosphere is not permitted.

## 4.6 Technical data

General	
Mains connection [U/f]	See rating plate
Power consumption [P <sub>1</sub> ]	See rating plate
Rated power [P <sub>2</sub> ]	See rating plate
Maximum delivery head [H]	See rating plate
Max. volume flow [Q]	See rating plate
Activation type [AT]	See rating plate
Fluid temperature [t]	3...40 °C
Protection class	IP68
Insulation class [Cl.]	F
Speed [n]	See rating plate
Max. switching frequency	30/h
Max. immersion depth [8]	See rating plate
Cable length (standard version)	10 m
Explosion protection	-
Operating modes	
Immersed [OTs]	S1
Non-immersed [OTe]	S2-15, S3 10 %*
Pressure connection	
FIT V05...	DN 50, PN 10
FIT V06...	DN 65/80, PN 10
FIT V08...	DN 80/100, PN 10
FIT V10...	DN 100, PN 10
Suction port	
FIT V05...	DN 50, PN 10
FIT V06...	DN 65, PN 10
FIT V08...	DN 80, PN 10
FIT V10...	DN 100, PN 10

\* Operating mode S3 25 % is permitted if the necessary motor cooling is guaranteed before the motor is switched on again! To ensure the required cooling, the motor must be completely immersed for at least 1 min.!

## 4.7 Type key

Example: Wilo-Rexa FIT V06DA-110/EAD1-2-T0015-540-P	
FIT	Series
V	Impeller = vortex impeller

Example: Wilo-Rexa FIT V06DA-110/EAD1-2-T0015-540-P	
06	Nominal diameter of pressure connection
D	Hydraulic version:
	D = suction side drilled acc. to DIN N = suction side drilled according to ANSI
A	Hydraulics material version: standard
110	Hydraulics definition
E	Motor version: surface-cooled motor
A	“Motor” material version: standard
D	Seal: two m.seals
1	IE-efficiency class (derived from IEC 60034-30)
-	Not Ex-rated
2	Number of poles
T	Mains connection version: M = 1~, T = 3~
001	/10 = Rated power $P_2$ in kW
5	
5	Frequency mains connection: 5 = 50 Hz, 6 = 60 Hz
40	Code for rated voltage
P	Additional electrical equipment:
	O = with free cable end
	A = with float switch and plug
	P = with plug

#### 4.8 Scope of delivery

- Pump with 10 m cable
- Single-phase version with
  - Shockproof plug
  - Float switch and shockproof plug
- Three-phase version with
  - Bare cable end
  - Float switch and CEE plug
- Installation and operating instructions

#### 4.9 Accessories

- Cable lengths in fixed length increments of 10 m to max. 30 m in the single-phase version or max. 50 m in three-phase current version
- Suspension unit
- Pump support foot
- External pencil electrode for sealing chamber control
- Level control devices
- Fixation accessories and chains
- Switchgear, relays and plugs

## 5 Transportation and storage

### 5.1 Delivery

After receiving the shipment, this must be checked immediately for defects (damage, completeness). Defects must be noted on the freight documentation! Furthermore, defects must be notified to the transport company or the manufacturer immediately on the day of receipt of shipment. Subsequently notified defects can no longer be asserted.

### 5.2 Transport



#### WARNING

##### Standing beneath suspended loads!

Never allow anyone to stand under suspended loads! Danger of (serious) injuries caused by falling parts. Loads may not be carried over work places where people are present!



#### WARNING

##### Head and foot injuries due to lack of protective equipment!

Danger of (serious) injuries during work. Wear the following protective equipment:

- Safety shoes
- Safety helmet must be used if lifting equipment are used!



#### NOTICE

##### Only use lifting equipment in a technically sound condition!

Only use lifting equipment in a technically sound condition for lifting, lowering and transporting the pump. Ensure that the pump does not become jammed during lifting and lowering. Do **not** exceed the max. permissible bearing capacity of the lifting equipment!

#### CAUTION

##### Soaked packaging may tear!

As a result, the device may fall on the ground unprotected and may be damaged. Soaked packaging must be lifted carefully and replaced immediately!

Only remove the outer packaging at the place of utilisation to ensure that the pump is not damaged during transport. Use tear-proof plastic sacks of sufficient size

to package used pumps for transport in a leak-proof manner.

The following points must also be observed:

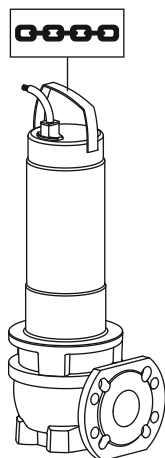

Fig. 2: Attachment point

- Adhere to the applicable national safety regulations.
- Use legally specified and approved lifting gear.
- Select the lifting gear based on the existing conditions (weather, attachment point, load, etc.).
- Only attach the lifting gear to the attachment point. Fix with a shackle.
- Use lifting equipment with sufficient bearing capacity.
- The stability of the lifting equipment must be ensured during operation.
- When using lifting equipment, a second person must be present to coordinate the procedure if required (e.g. if the operator's field of vision is blocked).

### 5.3 Storage



#### DANGER

##### **Danger due to fluids hazardous to health!**

If the pump is used in fluids hazardous to health, decontaminate the pump after dismantling and before carrying out any other work! There is danger to life! Observe the specifications in the work regulations! The operator must make sure that the personnel has received and read the work regulations!



#### WARNING

##### **Sharp edges on the impeller and suction port**

Sharp edges can form on the impeller and suction port. There is danger of limbs being cut-off! Protective gloves must be worn to protect from cuts.

### CAUTION

#### **Total damage due to moisture ingress**

Moisture ingress in the power supply cable damages the power supply cable and the pump! Never immerse the end of the power supply cable in a fluid and firmly seal it during storage.

Newly supplied pumps can be stored for one year. Contact customer service to store the pump for more than one year.

The following must be observed for storage:

- Securely position the pump on a firm bearing surface. Store pumps with pump support foot in an upright position, store pumps without pump support foot in a horizontal position. Secure the pump against falling over and slipping!
  - The max. storage temperature is  $-15\text{ °C}$  to  $+60\text{ °C}$  at a max. relative humidity of 90 %, non-condensing. Frost-proof storage at a temperature of  $5\text{ °C}$  to  $25\text{ °C}$  with relative humidity of 40 % to 50 % is recommended.
  - Do not store the pump in rooms in which welding work is carried out. The resulting gases or radiation can corrode the elastomer parts and coatings.
  - Seal the suction and pressure connection tightly.
  - Protect power supply cables against kinking and damage.
  - Protect the pump from direct sunlight and heat. Extreme heat can cause damage to the impellers and the coating!
  - Impellers must be turned by  $180\text{ °}$  at regular intervals (3 – 6 months). This prevents jamming of the bearings and renews the lubrication film of the mechanical seal. **WARNING! There is a risk of injury due to edges on the impeller and suction port!**
  - Elastomer parts and the coating are subject to natural brittleness. Contact customer service if the pump must be stored for more than 6 months.
- After storage, remove any dust and oil from the pump and check the coating for damage. Repair damaged coatings before further use.

## 6 Installation and electrical connection

### 6.1 Personnel qualifications

- Electrical work: Electrical work must be carried out by a qualified electrician (in accordance with EN 50110-1).

- Installation-/dismantling: The technician must be trained in the use of the necessary tools and mounting materials for the relevant construction site.

## 6.2 Installation types

- Vertical stationary wet well installation with suspension unit
- Vertical portable wet well installation with pump support foot

The following installation types are **not** allowed:

- Dry well installation
- Horizontal installation

## 6.3 Operator responsibilities

- Observe locally applicable accident prevention and safety regulations of trade associations.
- Observe all regulations for working with heavy loads and under suspended loads.
- Provide protective equipment and ensure that the protective equipment is worn by personnel.
- Observe local sewage technology regulations for the operation of sewage systems.
- Avoid pressure surges!

Pressure surges can occur in long discharge pipelines with steep terrain. These pressure surges can lead to the destruction of the pump!

- Ensure the cooling time of the motor depending on the operating conditions and the size of the pump chamber.
- Structural components and foundations must be of sufficient stability in order to allow the device to be fixed securely and functionally. The operator is responsible for the provision and suitability of the structural component/foundation!
- Check that the available consulting documents (installation plans, design of the operating space, inflow conditions) are complete and correct.

## 6.4 Installation



### **DANGER**

#### **Potentially fatal danger due to dangerous autonomous work!**

Work in chambers and narrow rooms as well as work involving risk of falling are dangerous work. Such work may not be carried out autonomously! A second person must be present for safety reasons.



### **WARNING**

#### **Hand and foot injuries due to lack of protective equipment!**

Danger of (serious) injuries during work. Wear the following protective equipment:

- Safety gloves against cuts
- Safety shoes
- Safety helmet must be used if lifting equipment are used!



### **NOTICE**

#### **Only use lifting equipment in a technically sound condition!**

Only use lifting equipment in a technically sound condition for lifting, lowering and transporting the pump. Ensure that the pump does not become jammed during lifting and lowering. Do **not** exceed the max. permissible bearing capacity of the lifting equipment!



### **NOTICE**

#### **Emerging of the motor during operation**

If the motor emerges during operation, the specifications for "Operating mode non-immersed" must be complied with!

To ensure that the motor is cooled during continuous duty, the motor must be immersed completely before switching it on again!

- Prepare operating space/installation location as follows:
  - Clean, free of coarse solids
  - Dry well
  - Frost-free
  - Decontaminated
- Take immediate countermeasures if there is a build-up of toxic or suffocating gases!
- Use the handle for lifting, lowering and transporting the pump. Never carry or drag the pump by the power supply cable!
- It must be possible to attach lifting equipment safely. The storage place and the operating space/installation site must be accessible with the lifting equipment. The set-down location must have a solid bearing surface.
- Attach the lifting gear to the handle using a shackle. Only use lifting gear which has been technically approved.
- The routed power supply cables must allow safe operation. Check whether the cable cross-section and the

cable length are sufficient for the selected installation type.

- The corresponding IP class must be observed when using switchgear. Install the switchgear overflow-proof and outside potentially explosive areas!
- Avoid air intake into the fluid, use baffles or deflector plates for the inlet. Air which has entered the system can collect in the pipe system and lead to impermissible operating conditions. Air pockets must be removed via ventilation systems!
- A dry run of the pump is prohibited! Avoid air pockets in the hydraulics housing or in the pipe system. Ensure the water level never falls below the minimum. The installation of a dry-running protection is recommended!

#### 6.4.1 Indications for double pump operation

If several pumps are used in an operating space, minimum distances between the pumps and the wall must be complied with. Here there is a difference in the distances depending on the type of system: Alternating operation or parallel operation.

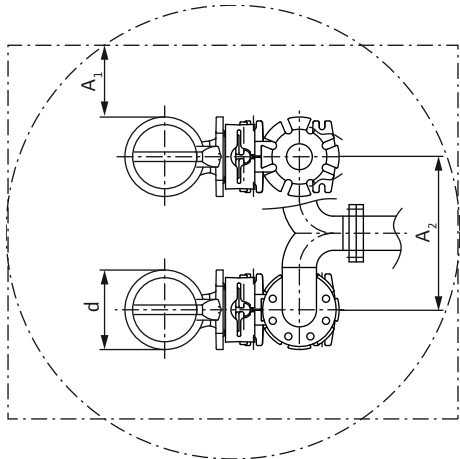

Fig. 3: Minimum distances

d	Diameter hydraulics housing
A <sub>1</sub>	Minimum distance from the wall: – alternating operation: min. $0.3 \times d$ – parallel operation: min. $1 \times d$
A <sub>2</sub>	Distance to discharge pipelines – alternating operation: min. $1.5 \times d$ – parallel operation: min. $2 \times d$

#### 6.4.2 Maintenance tasks

After a storage period of more than 6 months, carry out the following maintenance tasks before installation:

- Rotate the impeller.
- Check the oil in the sealing chamber.

#### 6.4.2.1 Rotate impeller



##### WARNING

##### Sharp edges on the impeller and suction port

Sharp edges can form on the impeller and suction port. There is danger of limbs being cut-off! Protective gloves must be worn to protect from cuts.

- ✓ Pump is **not** connected to the mains!
  - ✓ Protective equipment has been put on!
1. Place the pump horizontally on a firm surface. **WARNING! Risk of hands being crushed. Ensure that the pump cannot fall over or slip away!**
  2. Reach into the hydraulics housing carefully and slowly from below and turn the impeller.

#### 6.4.2.2 Check oil in the sealing chamber

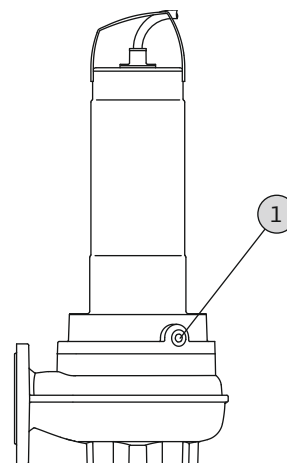

Fig. 4: Sealing chamber: Check the oil

##### 1 Screw plug sealing chamber

- ✓ Pump is **not** installed.
  - ✓ Pump is **not** connected to the mains.
  - ✓ Protective equipment has been put on!
1. Place the pump horizontally on a firm surface. The screw plug points upwards. **WARNING! Risk of hands being crushed. Ensure that the pump cannot fall over or slip away!**
  2. Unscrew the screw plug.
  3. Place a suitable tank to collect the operating fluid.
  4. Drain the operating fluid: Rotate the pump until the opening points downwards.
  5. Check the operating fluid:
    - ⇒ If the operating fluid is clear, reuse operating fluid.
    - ⇒ If the operating fluid is contaminated (black), fill with new operating fluid. Dispose of operating fluid in accordance with the local regulations!

⇒ Notify customer service if an operating fluid contains metal chips!

6. Pour in operating fluid: Rotate the pump until the opening points upwards. Fill-in the operating fluid into the opening.

⇒ Comply with the specifications for operating fluid locations and quantity! When recycling the operating fluid, check the quantity and if required adjust it!

7. Clean the screw plug, replace the seal ring and screw it back in. **Max. tightening torque: 8 Nm!**

### 6.4.3 Stationary wet well installation



#### NOTICE

#### Delivery problems due to water level being too low

The hydraulics are self-venting. As a result, smaller air cushions are dissolved during the pumping process. If the level of the fluid is lowered too much, the volume flow can be interrupted. The minimum permissible water level must reach the upper edge of the hydraulics housing!

The pump is installed in the fluid for the wet well installation. For this, a suspension unit must be installed in the chamber. On the pressure side, the on-site pipe system is connected to the suspension unit and on the suction side to the pump. The connected pipe system must be self-supporting. The suspension unit must **not** support the pipe system!

**CAUTION! If the motor emerges during operation, observe the operating mode for non-immersed operation (S2-15, S3 10 %\*):**

\* Operating mode S3 25 % is permitted if the necessary motor cooling is guaranteed before the motor is switched on again! To ensure the required cooling, the motor must be completely immersed for at least 1 min.!

#### Work steps

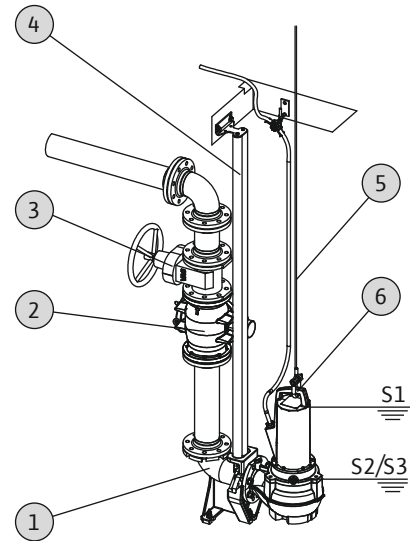

Fig. 5: Wet well installation, stationary

1	Suspension unit
2	Non-return valve
3	Stop valve
4	Guide pipe (provided by the customer)
5	Lifting equipment
6	Attachment point for the lifting equipment

- ✓ Operating space/installation location is prepared for the installation.
  - ✓ Suspension unit and pipe system were installed.
  - ✓ Pump is prepared for operation on the suspension unit.
1. Use a shackle to attach the lifting equipment to the attachment point of the pump.
  2. Lift the pump, swivel it above the chamber opening and slowly lower the guide claw onto the guide pipe.
  3. Lower the pump until it sets on the suspension unit and is connected automatically. **CAUTION! Hold the power supply cables slightly taut when lowering the pump!**
  4. Loosen the lifting equipment from the lifting gear and secure it at the chamber outlet against falling.
  5. Have the power supply cables routed into the chamber by a qualified electrician and route it outside properly from the chamber.
- The pump is installed, the qualified electrician can make the electrical connection.



#### 6.4.4 Portable wet well installation



##### WARNING

##### Risk of burns from hot surfaces!

Motor housing can become hot during operation. It may cause burns. Allow the pump to cool down at ambient temperature after switching it off!



##### WARNING

##### Separation of pressure hose!

Separation or movement of the pressure hose can lead to (serious) injuries. Securely attach the pressure hose to the outlet! Prevent buckling of the pressure hose.



##### NOTICE

##### Delivery problems due to water level being too low

The hydraulics are self-venting. As a result, smaller air cushions are dissolved during the pumping process. If the level of the fluid is lowered too much, the volume flow can be interrupted. The minimum permissible water level must reach the upper edge of the hydraulics housing!

For portable installation, the pump must be equipped with a pump support foot. The pump support foot ensures minimum ground clearance in the suction area and enables secure footing if placed on a solid bearing surface. In this installation type, the pump can be installed anywhere in the operating space/installation site. A hard base must be used at the installation location to prevent sinking in case of soft bearing surfaces. A pressure hose is connected on the pressure side. If operated for longer periods of time, fix the pump firmly to the floor. This prevents vibration and ensures quiet and low-wearing running.

**CAUTION! If the motor emerges during operation, observe the operating mode for non-immersed operation (S2-15, S3 10 %\*)!**

\* Operating mode S3 25 % is permitted if the necessary motor cooling is guaranteed before the motor is switched on again! To ensure the required cooling, the motor must be completely immersed for at least 1 min.!

#### Work steps

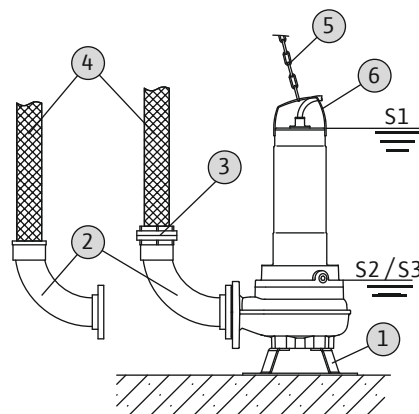

Fig. 6: Wet well installation; portable

1	Pump support foot
2	Pipe elbow with hose connection or Storz pipe coupling
3	Storz hose coupling
4	Pressure hose
5	Lifting equipment
6	Attachment point

- ✓ Pump support foot mounted.
  - ✓ Pressure connection prepared: Pipe elbow with hose connection or pipe elbow with Storz coupling mounted.
1. Use a shackle to attach the lifting equipment to the attachment point of the pump.
  2. Lift the pump and lower it at the intended location (chamber, pit).
  3. Place the pump on a solid bearing surface. **CAUTION! Sinking must be prevented!**
  4. Lay the pressure hose and fasten it to a certain point (e.g. drainage). **DANGER! Separation or movement of the pressure hose can lead to (serious) injuries! Securely attach the pressure hose to the outlet.**
  5. Lay the power supply cable properly. **CAUTION! Do not damage the power supply cable!**
- The pump is installed, the qualified electrician can make the electrical connection.

#### 6.4.5 Level control

With a level control device, the current fill levels are determined and the pump is switched on and off automatically depending on the fill levels. Fill levels are recorded by using different sensor types (float switches, pressure and ultrasound measurements or electrodes). The following must be observed when using a level control device:



- Float switches can move freely!
- The water level must **not fall below** the minimum permissible!
- The maximum switching frequency **must not be exceeded!**
- If the fill levels fluctuate strongly, a level control with two measuring points is recommended. This makes it possible to achieve larger differential gaps.

#### **Use of attached float switch**

The "A" version is equipped with a float switch. The pump is switched on and off depending on the fill level. The switching level is determined by the cable length of the float switch.

#### **Use of on-site level controls**

When using an on-site level control device, refer to the manufacturer's own installation and operating instructions for specifications on the installation.

#### **6.4.6 Dry-running protection**

Dry-running protection must prevent the pump from operating without fluid and air from entering the hydraulics. Minimum permissible fill level must be determined with the help of a signal transmitter. Once the specified limit value is reached, the pump must be deactivated with an appropriate signal. Dry-running protection can expand the available level controls by an additional measuring point or function as an independent switch-off device. Depending on the system security, the pump can be restarted automatically or manually. Installation of a dry-running protection is recommended for optimum operational reliability.

### **6.5 Electrical connection**



#### **DANGER**

#### **Risk of death due to electrocution!**

Improper conduct when carrying out electrical work can lead to death due to electric shock! Electrical work must be carried out by a qualified electrician in accordance with the locally applicable regulations.

- The mains connection must match the specifications on the rating plate.
- Power supply on mains side for three-phase current motors with clockwise rotating field.
- Lay the power supply cables in accordance with the locally applicable regulations and connect them according to the wire assignment.

- Connect the monitoring devices and check their function.
- Earth the device properly in accordance with the locally applicable regulations.

#### **6.5.1 Fuse on mains side**

##### **Circuit breaker**

The size of the circuit breakers conforms to the rated current of the pump. The switching characteristics should comply with group B or C. Observe local regulations.

##### **Motor protection switch**

Make provision for an on-site motor protection switch for devices without a plug! The minimum requirement is a thermal relay/motor protection switch with temperature compensation, differential triggering and anti-reactivation device in accordance with the local regulations. In case of sensitive mains, make provision for the installation on-site of other protective equipment (e.g. overvoltage, undervoltage or phase failure relay, etc.).

##### **Residual-current device (RCD)**

Comply with the regulations of the local energy supply company! The use of a residual-current device is recommended.

If persons come into contact with the device and conductive fluids, secure the connection **with** a residual-current device (RCD).

#### **6.5.2 Maintenance tasks**

Carry out the following maintenance tasks prior to installation:

- Check the insulation resistance of the motor winding.
- Test the resistor of the temperature sensor.
- Test the resistor of the pencil electrode (optionally available).

If the measured values differ from the specifications, moisture may have penetrated into the motor or the power supply cable or the monitoring device is defective. Contact customer service in the event of a fault.

##### **6.5.2.1 Checking the insulation resistance of the motor winding**

Use an insulation tester to measure the insulation resistance (measuring voltage = 1000 V). Observe the following values:

- At the time of initial commissioning: Insulation resistance may not be less than 20 MΩ.
- For further measurements: Value must be greater than 2 MΩ.

**NOTICE!** For motors with an integrated capacitor, short-circuit the windings prior to checking!

### 6.5.2.2 Test the resistor of the temperature sensor

Measure the resistor of the temperature sensors with an ohmmeter. The bimetallic strips must have a measured value of 0 Ohm (passage).

### 6.5.2.3 Testing the resistor of the external electrode for sealing chamber control

Measure the resistor of the electrode with an ohmmeter. The measured value must approach "infinity".

For values  $\leq 30$  kOhm, if there is water in the oil – change the oil!

### 6.5.3 Connection of the single-phase motor

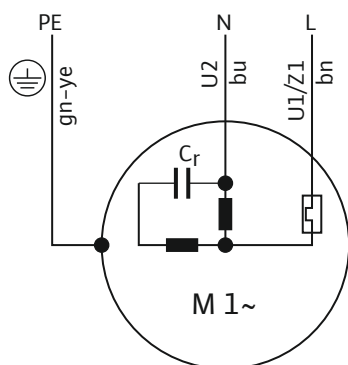

Fig. 7: Connection diagram single-phase motor

Wire colour	Terminal
Brown (bn)	L
Blue (bu)	N
Green/yellow (gn-ye)	Earth

The single-phase current version is equipped with a shockproof plug. The connection to the mains is established by inserting the plug into a socket. The plug is **not** overflow-proof. **Install the socket so that it is overflow-proof!** Observe the information on the protection class (IP) of the plug.

**DANGER! If the pump is connected directly to the switchgear, dismantle the plug and arrange for the electrical connection to be carried out by a qualified electrician!**

### 6.5.4 Connection three-phase motor

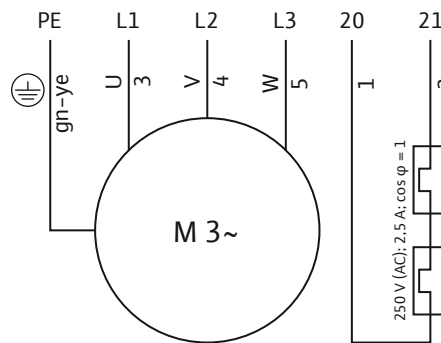

Fig. 8: Connection diagram three-phase motor

Wire number	Designation	Terminal
1	20	WSK
2	21	WSK
3	U	L1
4	V	L2
5	W	L3
Green/yellow (gn-ye)	Earth	PE

For three-phase current motors, a clockwise rotating field must be available. The three-phase version is equipped with a CEE plug or with a free cable end:

- If a CEE plug is supplied, connection to the mains is established by inserting the plug into a socket. The plug is **not** overflow-proof. **Install the socket so that it is overflow-proof!** Observe the information on the protection class (IP) of the plug.
- If there is a free cable-end, the pump must be connected directly to the switchgear. **DANGER! If the pump is connected directly to the switchgear, arrange for the electrical connection to be carried out by a qualified electrician!**

### 6.5.5 Monitoring equipment connection

**All monitoring equipment must be connected!**

#### 6.5.5.1 Monitoring of motor winding

##### *Single-phase current motor*

Thermal motor monitoring is self-switching for single-phase current motors. The monitoring function is always active and does not need to be connected separately.

##### *Three-phase current motor with bimetallic strip*

Bimetallic strips are connected in the switchgear itself or via an evaluation relay.

Connection values: max. 250 V(AC), 2.5 A,  $\cos \varphi = 1$

**When the threshold is reached, deactivation must take place.**

In the version with an attached plug, the thermal motor monitoring is pre-wired and set to the correct value in the plug.

#### 6.5.5.2 Sealing chamber monitoring (external electrode)

Connect the external electrode via an evaluation relay. Relay "NIV 101/A" is recommended for this. The threshold is 30 kOhm.

**When the threshold is reached, a warning must be given or the unit must be switched off.**

#### CAUTION

##### Connection of the sealing chamber control

If on reaching the threshold, there is only a warning, the pump could be irreparably damaged by the water ingress. Deactivation of the pump is always recommended!

#### 6.5.6 Motor protection adjustment

Motor protection must be set depending on the selected activation type.

##### 6.5.6.1 Direct activation

At full load, set the motor protection switch to the rated current (see rating plate). At partial load, it is recommended to set the motor protection switch 5 % above the current measured at the duty point.

##### 6.5.6.2 Soft starter

At full load, set the motor protection switch to the rated current (see rating plate). At partial load, it is recommended to set the motor protection switch 5 % above the current measured at the duty point. The following must also be observed:

- Power consumption must always be below the rated current.
- Complete starting and stopping within 30 s.
- To avoid power dissipation, bypass the electronic starter (soft start) once normal operation is reached.

##### 6.5.7 Operation with frequency converter

Operation on the frequency converter is not permitted.

## 7 Commissioning



### WARNING

#### Foot injuries due to lack of protective equipment!

Danger of (serious) injuries during work. Wear safety shoes!

### 7.1 Personnel qualifications

- Electrical work: Electrical work must be carried out by a qualified electrician (in accordance with EN 50110-1).
- Operation/control: Operating personnel must be instructed in the functioning of the complete system.

### 7.2 Operator responsibilities

- Providing installation and operating instructions by the pump or at a place specially reserved for it.
- Making the installation and operating instructions available in the language of the personnel.
- Making sure that the installation and operating instructions are read and understood by all personnel.
- All safety devices and emergency cut-outs on the system-side must be active and checked to ensure that they work properly.
- The pump is suitable for use under the specified operating conditions.

### 7.3 Direction of rotation check (for three-phase current motors only)

The pump is factory-checked and adjusted to the correct direction of rotation for a clockwise rotating field. Connection is made in accordance with the specifications in chapter "Electrical connection".

#### Direction of rotation check

A qualified electrician checks the rotating field at the mains connection with a rotating field-test device. For the correct direction of rotation, a clockwise rotating field must be available at the mains connection. The pump is **not** approved for operation with a counter-clockwise rotating field! **CAUTION! If the direction of rotation is checked with a test run, comply with the ambient and operating conditions!**

#### Incorrect direction of rotation

If the direction of rotation is incorrect, change the connection as follows:

- Swap two phases for motors with direct starting.
- Swap the connections of two windings (e.g. U1/V1 and U2/V2) for star-delta activation motors.

#### 7.4 Before switching on

Check the following prior to activation:

- Check whether the device has been installed properly and in accordance with the locally applicable regulations:
  - Has the pump been earthed?
  - Layout of power supply cable tested?
  - Electrical connection made properly?
  - Mechanical components attached correctly?
- Check level control:
  - Float switches can move freely?
  - Switching level tested (pump on, pump off, minimum water level)?
  - Additional dry-running protection installed?
- Test operating conditions:
  - Min./max. temperature of the fluid tested?
  - Max. immersion depth tested?
  - Operating mode defined depending on the minimum water level?
  - Maximum switching frequency adhered to?
- Check installation location/operating space:
  - Pipe system on the pressure side free of deposits?
  - Inlet or pump sump cleaned or free of deposits?
  - All gate valves open?
  - Minimum water level defined and monitored?  
The hydraulics housing must be filled completely with the fluid and there must be no air cushions in the hydraulics. **NOTICE! Provide suitable venting devices if there is a risk of air cushions being formed in the system!**

#### 7.5 Switch on and off

During the start process, the rated current is temporarily exceeded. During operation, the rated current may no longer be exceeded. **CAUTION! If the pump does not start, switch off the pump immediately. Remove the fault before reactivating the pump!**

Place pumps which are installed as portable pumps on a firm surface so they are level. If pumps have fallen over, place them upright again before activating them. Securely attach the pump with screws in case of difficult surfaces.

##### **Pump with attached float switch and plug**

- Single-phase current version: After inserting the plug into the socket, the pump is ready for operation. The pump is switched on and off automatically depending on the fill level.

- Three-phase version: After inserting the plug into the socket, the pump is ready for operation. The pump is controlled via two switches on the plug:
  - HAND/AUTO: Determines if the pump is switched on and off directly (HAND) or depending on the fill level (AUTO).
  - ON/OFF: Switch pump on and off.

##### **Pump with attached plug**

- Single-phase current version: After inserting the plug in the socket, the pump is switched on.
- Three-phase version: After inserting the plug into the socket, the pump is ready for operation. The pump is switched on and off with the ON/OFF switch.

##### **Pumps with free cable end**

The pump must be switched on and off using a separate operating point (on/off switch, switchgear) provided by the customer.

#### 7.6 During operation



##### **WARNING**

##### **Amputation of limbs due to rotating components!**

No persons must be present in the work area of the pump! There is risk of (serious) injuries due to rotating components! No persons must be present in the work area of the pump during start-up or operation.



##### **WARNING**

##### **Risk of burns from hot surfaces!**

Motor housing can become hot during operation. It may cause burns. Allow the pump to cool down at ambient temperature after switching it off!



##### **NOTICE**

##### **Delivery problems due to water level being too low**

The hydraulics are self-venting. As a result, smaller air cushions are dissolved during the pumping process. If the level of the fluid is lowered too much, the volume flow can be interrupted. The minimum permissible water level must reach the upper edge of the hydraulics housing!

When operating the pump, observe the locally applicable regulations on the following topics:

- Work safety
- Accident prevention

- Handling electrical machines

Strictly adhere to the responsibilities of the personnel specified by the operator. All personnel are responsible for ensuring that the responsibilities of the personnel and the regulations are observed!

Due to their design, centrifugal pumps have rotating parts that are easily accessible. Depending on the operating condition, sharp edges can develop on these parts. **WARNING! This can lead to cuts and limbs may be amputated and severed!** Check the following at regular intervals:

- Operating voltage (+/-10 % of the rated voltage)
- Frequency (+/-2 % of the rated frequency)
- Power consumption between individual phases (max. 5 %)
- Voltage difference between the individual phases (max. 1 %)
- Max. switching frequency
- Minimum water submersion depending on the operating mode
- Inlet: no air intake
- Level control device/dry-running protection: Switching points
- Quiet/low-vibration running
- All gate valves open

## 8 Decommissioning/dismantling

### 8.1 Personnel qualifications

- Operation/control: Operating personnel must be instructed in the functioning of the complete system.
- Electrical work: Electrical work must be carried out by a qualified electrician (in accordance with EN 50110-1).
- Installation-/dismantling: The technician must be trained in the use of the necessary tools and mounting materials for the relevant construction site.

### 8.2 Operator responsibilities

- Locally applicable accident prevention and safety regulations of trade associations.
- Observe regulations for working with heavy loads and under suspended loads.
- Provide the necessary protective equipment and make sure that the personnel wears it.
- Provide adequate aeration in closed rooms.
- Take immediate countermeasures if there is a build-up of toxic or suffocating gases!

### 8.3 Decommissioning

The pump is deactivated during decommissioning, but remains installed. This ensures that the pump is always ready for operation.

- ✓ To protect the pump from frost and ice, always immerse the pump completely in the fluid.
- ✓ Temperature of the fluid must always be above +3 °C.

1. Switch off the pump at the operating point.
2. Secure the operating point against being switched on again by unauthorised persons (e.g. lock main switch).

- ▶ The pump is out of operation and can now be dismantled.

If the pump remains installed after decommissioning, observe the following:

- Ensure that the prerequisites for decommissioning are maintained for the complete period of decommissioning. If these prerequisites cannot be guaranteed, dismantle the pump after decommissioning!
- For an extended period of decommissioning, carry out a 5-minute function test at regular intervals (monthly to quarterly). **CAUTION! A function test may only be carried out under the applicable operating conditions. A dry run is not permitted! Non-compliance can result in irreparable damage!**

### 8.4 Removal



#### DANGER

#### Danger due to fluids hazardous to health!

If the pump is used in fluids hazardous to health, decontaminate the pump after dismantling and before carrying out any other work! There is danger to life! Observe the specifications in the work regulations! The operator must make sure that the personnel has received and read the work regulations!



#### DANGER

#### Risk of death due to electrocution!

Improper conduct when carrying out electrical work can lead to death due to electric shock! Electrical work must be carried out by a qualified electrician in accordance with the locally applicable regulations.

**DANGER****Potentially fatal danger due to dangerous autonomous work!**

Work in chambers and narrow rooms as well as work involving risk of falling are dangerous work. Such work may not be carried out autonomously! A second person must be present for safety reasons.

**WARNING****Risk of burns from hot surfaces!**

Motor housing can become hot during operation. It may cause burns. Allow the pump to cool down at ambient temperature after switching it off!

**NOTICE****Only use lifting equipment in a technically sound condition!**

Only use lifting equipment in a technically sound condition for lifting, lowering and transporting the pump. Ensure that the pump does not become jammed during lifting and lowering. Do **not** exceed the max. permissible bearing capacity of the lifting equipment!

**8.4.1 Stationary wet well installation**

- ✓ Pump is decommissioned.
  - ✓ Gate valves on the inlet and pressure side closed.
1. Disconnect the pump from the mains.
  2. Attach the lifting equipment to the attachment point.  
**CAUTION! Never pull on the power supply cable! This damages the power supply cable!**
  3. Slowly raise the pump and lift above the guide pipes from the operating space. **CAUTION! The power supply cable can be damaged while lifting! Hold the power supply cable slightly taut when lifting!**
  4. Clean pump thoroughly (see point “Cleaning and disinfecting”). **DANGER! Disinfect the pump when used in fluids hazardous to health!**

**8.4.2 Portable wet well installation**

- ✓ Pump is taken out of operation.
1. Disconnect the pump from the mains.
  2. Roll up the power supply cable and place it over the motor housing. **CAUTION! Never pull on the power supply cable! This damages the power supply cable!**
  3. Loosen the pressure pipe from the pressure port.

4. Attach the lifting equipment to the attachment point.
5. Lift the pump from the operating space. **CAUTION! The power supply cable may be squeezed and damaged when setting the pump down! Pay attention to the power supply cable when setting the pump down!**
6. Clean pump thoroughly (see point “Cleaning and disinfecting”). **DANGER! Disinfect the pump when used in fluids hazardous to health!**

**8.4.3 Clean and disinfect****DANGER****Danger due to fluids hazardous to health!**

Danger to life if the pump is used in fluids hazardous to health! Decontaminate the pump before carrying out any further work! Wear the following protective equipment while performing cleaning tasks:

- Closed safety goggles
- Breathing mask
- Protective gloves

⇒ **The equipment listed here is the minimum requirement, observe the specifications of the work regulations! The operator must make sure that the personnel has received and read the work regulations!**



- ✓ Pump is dismantled.
  - ✓ The contaminated cleaning water is disposed of in the sewage in accordance with the locally applicable regulations.
  - ✓ A disinfectant is provided for contaminated pumps.
1. Attach the lifting equipment to the attachment point of the pump.
  2. Lift the pump approximately 30 cm above the ground.
  3. Spray the pump with clear water from top to bottom.  
**NOTICE! An appropriate disinfectant must be used for contaminated pumps! Strictly observe the manufacturer's specifications concerning use!**
  4. To clean the impeller and the interior pump space, guide the water jet inside via the pressure port.
  5. Flush all dirt residue onto the floor of the channel.
  6. Allow the pump to dry out.

## 9 Maintenance and repair



### DANGER

#### Danger due to fluids hazardous to health!

If the pump is used in fluids hazardous to health, decontaminate the pump after dismantling and before carrying out any other work! There is danger to life! Observe the specifications in the work regulations! The operator must make sure that the personnel has received and read the work regulations!



### NOTICE

#### Only use lifting equipment in a technically sound condition!

Only use lifting equipment in a technically sound condition for lifting, lowering and transporting the pump. Ensure that the pump does not become jammed during lifting and lowering. Do **not** exceed the max. permissible bearing capacity of the lifting equipment!

- Always carry out maintenance tasks in a clean location with good lighting. It must be possible to position the pump safely and secure it.
- Only carry out maintenance tasks mentioned in this installation and operating instructions.
- Wear the following protective equipment while performing maintenance tasks:
  - Safety goggles
  - Safety shoes
  - Safety gloves

### 9.1 Personnel qualifications

- Electrical work: Electrical work must be carried out by a qualified electrician (in accordance with EN 50110-1).
- Maintenance tasks: The technician must be familiar with the use of operating fluids and their disposal. In addition, the technician must have basic knowledge of mechanical engineering.

### 9.2 Operator responsibilities

- Provide the necessary protective equipment and make sure that the personnel wears it.
- Collect operating fluids in suitable tanks and disposed of properly.
- Dispose of protective clothing used in accordance with regulations.
- Use only original parts of the manufacturer. Use of parts other than the original parts releases the manufacturer from any liability.

- Collect any leakage of fluid and operating fluid immediately and dispose of it according to the locally applicable guidelines.
- Provide the tools required.
- If flammable solvents and cleaning agents are used, open flames, naked lights and smoking are prohibited.

## 9.3 Operating fluid

### 9.3.1 Oil types

Biological white oil is filled-in into the sealing chamber. The following oil types are recommended when changing the oil:

- Aral Autin PL\*
- Shell ONDINA 919
- Esso MARCOL 52\* or 82\*
- BP WHITEMORE WOM 14\*
- Texaco Pharmaceutical 30\* or 40\*

All oil types marked with "\*" are approved for use with foods in accordance with "USDA-H1".

### 9.3.2 Filling quantities

The filling quantities depend on the pump type:

- Rexa FIT V.../EAD1-2...: 900 ml
- Rexa FIT V.../EAD1-4...: 1500 ml

## 9.4 Maintenance intervals

To ensure reliable operation, maintenance tasks must be carried out regularly. Depending on the real ambient temperatures, maintenance intervals different from those mentioned in the contract can be defined! If strong vibrations occur during operation, the pump and the installation must be checked regardless of the defined maintenance intervals.

### 9.4.1 Maintenance intervals for normal conditions 2 years

- Visual inspection of the power supply cable
- Visual inspection of accessories
- Visual inspection of the housing for wear
- Function test of monitoring devices
- Oil change

**NOTICE! If sealing chamber control is installed, the oil is changed according to the indicator!**

### 9.4.2 Maintenance intervals for use in sewage lifting units

When the pump is used in sewage lifting units inside buildings or on plots of land, carry out maintenance intervals and measures in accordance with

**DIN EN 12056-4!**



### 9.4.3 Maintenance intervals for harsh conditions

Under harsh operating conditions, specified maintenance intervals must be shortened if required. Harsh operating conditions include:

- Fluids with long-fibre components
- Turbulent inlet (e.g. due to air intake, cavitation)
- Strongly corroding or abrasive fluids
- Heavily gas generating fluids
- Operation at an unfavourable duty point
- Pressure surges

When using pumps under hard conditions, it is recommended to sign a maintenance contract. Contact customer service.

## 9.5 Maintenance measures



### WARNING

#### Sharp edges on the impeller and suction port

Sharp edges can form on the impeller and suction port. There is danger of limbs being cut-off! Protective gloves must be worn to protect from cuts.



### WARNING

#### Hand, foot or eye injuries due to lack of protective equipment!

Danger of (serious) injuries during work. Wear the following protective equipment:

- Safety gloves against cuts
- Safety shoes
- Closed safety goggles



The following pre-requisites must be fulfilled prior to starting maintenance measures:

- Pump cooled down to the ambient temperature.
- Pump cleaned thoroughly and disinfected (if required).

### 9.5.1 Recommended maintenance measures

Regular inspection of power consumption and the operating voltage in all three phases is recommended for smooth operation. In normal operation, these values remain constant. Slight fluctuations depend on the characteristics of the fluid. Power consumption can provide an early indication of damage or malfunctions in the impeller, bearings or motor, which can be rectified. Larger voltage fluctuations strain the motor winding and can cause the pump to break down. Regular inspections can therefore largely prevent major secondary damage and reduce the risk of total breakdown. In this regard, it is recommended to use remote monitoring for regular inspections.

### 9.5.2 Visual inspection of the power supply cable

The power supply cables must be checked for:

- Bubbles
- Cracks
- Scratches
- Abrasion
- Crushing

If the power supply cables are damaged, the pump must be decommissioned immediately! Customer service must replace the damaged power supply cable. The pump may only be started up again once the damage has been properly remedied.

**CAUTION! Water may penetrate into the pump due to the damaged power supply cables! Water ingress leads to total damage of the pump.**

### 9.5.3 Visual inspection of accessories

Accessories must be checked for:

- Correct fixation
- Smooth function
- Wear symptoms

Detected defects must be repaired immediately or the accessories must be replaced.

### 9.5.4 Visual inspection of the housing for wear

The housing parts are not allowed to have any apparent damage. Contact customer service if defects are detected!

### 9.5.5 Function test of the monitoring equipment

To test resistances, the pump must be cooled down to the ambient temperature!

#### 9.5.5.1 Test the resistor of the temperature sensor

Measure the resistor of the temperature sensors with an ohmmeter. The bimetallic strips must have a measured value of 0 Ohm (passage).

#### 9.5.5.2 Testing the resistor of the external electrode for sealing chamber control

Measure the resistor of the electrode with an ohmmeter. The measured value must approach "infinity". For values  $\leq 30$  kOhm, if there is water in the oil – change the oil!



9.5.6 Oil change in sealing chamber



**WARNING**

**Operating fluid under high pressure!**

A pressure of **several bar can build up** in the motor! This pressure escapes when the screw plugs are **opened**. If screw plugs are opened without due caution, they can be ejected at high speed! To avoid injuries, observe the following instructions:

- Adhere to the prescribed sequence of work steps.
- Unscrew the screw plugs slowly, but never unscrew them completely. As soon as the pressure escapes (audible whistling or hissing of air), stop turning the screw plug any further!
- When the pressure has completely dissipated, fully unscrew the screw plugs.
- Wear closed safety goggles.



**WARNING**

**Scalding due to hot operating fluids!**

Hot operating fluids can also spray out when the pressure is escaping. This can result in scalding! To avoid injuries, the following instructions must be observed:

- Allow the pump to cool down to the ambient temperature then open the screw plugs.
- Wear closed safety goggles or face protection and gloves.

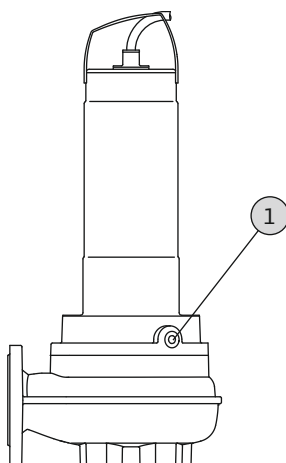

Fig. 9: Sealing chamber: Oil change

1	Screw plug sealing chamber
---	----------------------------

- ✓ Protective equipment has been put on!
- ✓ Pump has been dismantled and cleaned (decontaminated if required).

1. Position the pump horizontally on a firm surface. The screw plug points upwards. **WARNING! Risk of hands being crushed. Ensure that the pump cannot fall over or slip away!**
2. Unscrew the screw plug slowly, but do not unscrew it completely. **WARNING! Overpressure in the motor! Stop turning the screw plug further if hissing or whistling is audible! Wait until the pressure has completely dissipated.**
3. After the pressure has dissipated, fully unscrew the screw plug.
4. Place a suitable tank to collect the operating fluid.
5. Drain the operating fluid: Rotate the pump until the opening points downwards.
6. Check the operating fluid: Notify customer service if an operating fluid contains metal chips!
7. Pour in operating fluid: Rotate the pump until the opening points upwards. Fill-in the operating fluid into the opening.
  - ⇒ Comply with the specifications for operating fluid locations and quantity!
8. Clean the screw plug, replace the seal ring and screw it back in. **Max. tightening torque: 8 Nm!**

10 Faults, causes and remedies



**DANGER**

**Danger due to fluids hazardous to health!**

Danger of death in case of pumps with fluids hazardous to health! Wear the following protective equipment while performing the work:

- Closed safety goggles
- Breathing mask
- Protective gloves

⇒ **The equipment listed here is the minimum requirement, observe the specifications of the work regulations! The operator must make sure that the personnel has received and read the work regulations!**



**DANGER**

**Risk of death due to electrocution!**

Improper conduct when carrying out electrical work can lead to death due to electric shock! Electrical work must be carried out by a qualified electrician in accordance with the locally applicable regulations.

**DANGER****Potentially fatal danger due to dangerous autonomous work!**

Work in chambers and narrow rooms as well as work involving risk of falling are dangerous work. Such work may not be carried out autonomously! A second person must be present for safety reasons.

**WARNING****No persons are allowed to be present inside the working area of the pump!**

Persons may suffer (serious) injuries while the pump is in operation! No persons may therefore be present inside the working area. If persons must enter the working area of the pump, the pump must be de-commissioned and secured against being switched on again without authorisation.

**WARNING****Sharp edges on the impeller and suction port**

Sharp edges can form on the impeller and suction port. There is danger of limbs being cut-off! Protective gloves must be worn to protect from cuts.

***Fault: Pump is not starting***

1. Electricity supply interrupted or short-circuit/earth connection in the cable or motor winding.
  - ⇒ Have the connection and motor checked by a qualified electrician and replace if necessary.
2. Tripping of fuses, of the motor protection switch or the monitoring equipment
  - ⇒ Have the connection and the monitoring equipment checked by a qualified electrician and change it if necessary.
  - ⇒ Have the motor protection switches and fuses installed and adjusted according to the technical specifications by a qualified electrician and reset monitoring equipment.
  - ⇒ Check the impeller to make sure that it runs smoothly, clean the hydraulics if necessary.
3. The sealing chamber control (optional) has interrupted the electric circuit (connection-related)
  - ⇒ See "Fault: Mechanical seal leakage, sealing chamber control reports a fault and switches the pump off".

***Fault: Pump starts up, motor protection trips after short period***

1. Motor protection switch set incorrectly.
  - ⇒ Have the adjustment of the trigger checked and corrected by a qualified electrician.
2. Increased power consumption due to major voltage drop.
  - ⇒ Have the voltage of individual phases checked by a qualified electrician. Contact the electricity distribution network.
3. There are only two phases at the connection.
  - ⇒ Have the connection checked and corrected by a qualified electrician.
4. Excessive differences in voltage between the phases.
  - ⇒ Have the voltage of individual phases checked by a qualified electrician. Contact the electricity distribution network.
5. Incorrect direction of rotation.
  - ⇒ Have the connection corrected by a qualified electrician.
6. Increased power consumption through jammed hydraulics.
  - ⇒ Clean the hydraulics and check the inlet.
7. The density of the fluid is too high.
  - ⇒ Contact customer service.

***Fault: Pump runs, there is no volume flow***

1. There is no fluid.
  - ⇒ Check the inlet, open all gate valves.
2. Inlet clogged.
  - ⇒ Check the inlet and remove clogging.
3. Hydraulics jammed.
  - ⇒ Clean the hydraulics.
4. Pipe system on the pressure side or pressure hose clogged.
  - ⇒ Remove clogging and replace the damaged components if necessary.
5. Intermittent operation.
  - ⇒ Check the switching system.

***Fault: Pump starts, duty point is not reached***

1. Inlet clogged.
  - ⇒ Check the inlet and remove clogging.
2. Slide valves on the pressure side closed.
  - ⇒ Open all gate valves completely.
3. Hydraulics jammed.
  - ⇒ Clean the hydraulics.

4. Incorrect direction of rotation.
  - ⇒ Have the connection corrected by a qualified electrician.
5. Air cushion in the pipe system.
  - ⇒ Vent the pipe system.
  - ⇒ If air cushions occur frequently: Locate and prevent the air intake, if required install ventilation systems at specified locations.
6. Pump pumping against excessive pressure.
  - ⇒ Open all gate valves on the pressure side completely.
  - ⇒ Check the impeller shape, use other impeller shapes if required. Contact customer service.
7. Signs of wear on the hydraulics.
  - ⇒ Have the components (impeller, suction port, pump housing) checked and replaced by customer service.
8. Pipe system on the pressure side or pressure hose clogged.
  - ⇒ Remove clogging and replace the damaged components if necessary.
9. Strongly gassing fluid.
  - ⇒ Contact customer service.
10. There are only two phases at the connection.
  - ⇒ Have the connection checked and corrected by a qualified electrician.
11. Excessive decrease in the fill level during operation.
  - ⇒ Check supply/capacity of the system.
  - ⇒ Have the switching points of the level control checked and adjusted if necessary.

**Fault: The pump does not run smoothly and is noisy**

1. Improper duty point.
  - ⇒ Check the pump configuration and the duty point, contact customer service.
2. Hydraulics jammed.
  - ⇒ Clean the hydraulics.
3. Strongly gassing fluid.
  - ⇒ Contact customer service.
4. There are only two phases at the connection.
  - ⇒ Have the connection checked and corrected by a qualified electrician.
5. Incorrect direction of rotation.
  - ⇒ Have the connection corrected by a qualified electrician.
6. Signs of wear on the hydraulics.

⇒ Have the components (impeller, suction port, pump housing) checked and replaced by customer service.

7. Motor bearings have worn.
  - ⇒ Inform customer service; send the pump back to the factory for overhauling.
8. Pump is installed under tension.
  - ⇒ Check installation, install rubber compensators if necessary.

**Fault: Sealing chamber control reports fault or switches the pump off**

1. Condensation water build-up due to extended storage or high temperature fluctuations.
  - ⇒ Operate the pump for a short period (max. 5 min.) without pencil electrode.
2. Increased leakage when running in new mechanical seals.
  - ⇒ Change the oil.
3. Pencil electrode cable is defective.
  - ⇒ Replace the pencil electrode.
4. Mechanical seal is defective.
  - ⇒ Inform customer service.

**Further steps for troubleshooting**

If the points listed here do not rectify the fault, customer service must be contacted. Customer service can provide the following remedies:

- Telephone or written support.
- On-site support.
- Inspection and repair of the pump at the factory.

Costs may be incurred if other services of the customer service are availed! For more details, please contact customer service.

## 11 Spare parts

Spare parts are ordered via customer service. To avoid return queries and incorrect orders, the serial or article number must always be supplied. **Subject to change without prior notice.**

## 12 Disposal

### 12.1 Oils and lubricants

Operating fluid must be collected in suitable tanks and disposed off in accordance with the locally applicable guidelines.

## 12.2 Protective clothing

Used protective clothing must be disposed off in accordance with the locally applicable guidelines.

## 12.3 Information on the collection of used electrical and electronic products

Proper disposal and appropriate recycling of this product prevents damage to the environment and dangers to your personal health.



### NOTICE

#### **Disposal in domestic waste is forbidden!**

In the European Union, this symbol can appear on the product, the packaging or the accompanying documentation. It means that the electrical and electronic products in question must not be disposed of along with domestic waste.

---

To ensure proper handling, recycling and disposal of the used products in question, please note the following points:

- Only hand over these products at designated, certified collecting points.
- Observe the locally applicable regulations!

Please consult your local municipality, the nearest waste disposal site, or the dealer who sold the product to you for information on proper disposal. For further information on recycling, go to [www.wilo-recycling.com](http://www.wilo-recycling.com).





## Wilo – International (Subsidiaries)

### Argentina

WILO SALMSON  
Argentina S.A.  
C1295ABI Ciudad  
Autónoma de Buenos Aires  
T +54 11 4361 5929  
carlos.musich@wilo.com.ar

### Australia

WILO Australia Pty Limited  
Murrarie, Queensland, 4172  
T +61 7 3907 6900  
chris.dayton@wilo.com.au

### Austria

WILO Pumpen Österreich  
GmbH  
2351 Wiener Neudorf  
T +43 507 507-0  
office@wilo.at

### Azerbaijan

WILO Caspian LLC  
1065 Baku  
T +994 12 5962372  
info@wilo.az

### Belarus

WILO Bel IOOO  
220035 Minsk  
T +375 17 3963446  
wilo@wilo.by

### Belgium

WILO NV/SA  
1083 Ganshoren  
T +32 2 4823333  
info@wilo.be

### Bulgaria

WILO Bulgaria EOOD  
1125 Sofia  
T +359 2 9701970  
info@wilo.bg

### Brazil

WILO Comercio e  
Importacao Ltda  
Jundiaí – São Paulo – Brasil  
13.213-105  
T +55 11 2923 9456  
wilo@wilo-brasil.com.br

### Canada

WILO Canada Inc.  
Calgary, Alberta T2A 5L7  
T +1 403 2769456  
info@wilo-canada.com

### China

WILO China Ltd.  
101300 Beijing  
T +86 10 58041888  
wilobj@wilo.com.cn

### Croatia

WILO Hrvatska d.o.o.  
10430 Samobor  
T +38 51 3430914  
wilo-hrvatska@wilo.hr

### Cuba

WILO SE  
Oficina Comercial  
Edificio Simona Apto 105  
Siboney, La Habana. Cuba  
T +53 5 2795135  
T +53 7 272 2330  
raul.rodriguez@wilo-cuba.com

### Czech Republic

WILO CS, s.r.o.  
25101 Cestlice  
T +420 234 098711  
info@wilo.cz

### Denmark

WILO Danmark A/S  
2690 Karlslunde  
T +45 70 253312  
wilo@wilo.dk

### Estonia

WILO Eesti OÜ  
12618 Tallinn  
T +372 6 509780  
info@wilo.ee

### Finland

WILO Finland OY  
02330 Espoo  
T +358 207401540  
wilo@wilo.fi

### France

Wilo Salmson France S.A.S.  
53005 Laval Cedex  
T +33 2435 95400  
info@wilo.fr

### Great Britain

WILO (U.K.) Ltd.  
Burton Upon Trent  
DE14 2WJ  
T +44 1283 523000  
sales@wilo.co.uk

### Greece

WILO Hellas SA  
4569 Anixi (Attika)  
T +302 10 6248300  
wilo.info@wilo.gr

### Hungary

WILO Magyarország Kft  
2045 Törökbálint  
(Budapest)  
T +36 23 889500  
wilo@wilo.hu

### India

Wilo Mather and Platt Pumps  
Private Limited  
Pune 411019  
T +91 20 27442100  
services@matherplatt.com

### Indonesia

PT. WILO Pumps Indonesia  
Jakarta Timur, 13950  
T +62 21 7247676  
citrawilo@cbn.net.id

### Ireland

WILO Ireland  
Limerick  
T +353 61 227566  
sales@wilo.ie

### Italy

WILO Italia s.r.l.  
Via Novegro, 1/A20090  
Segrate MI  
T +39 25538351  
wilo.italia@wilo.it

### Kazakhstan

WILO Central Asia  
050002 Almaty  
T +7 727 312 40 10  
info@wilo.kz

### Korea

WILO Pumps Ltd.  
20 Gangseo, Busan  
T +82 51 950 8000  
wilo@wilo.co.kr

### Latvia

WILO Baltic SIA  
1019 Riga  
T +371 6714-5229  
info@wilo.lv

### Lebanon

WILO LEBANON SARL  
Jdeideh 1202 2030  
Lebanon  
T +961 1 888910  
info@wilo.com.lb

### Lithuania

WILO Lietuva UAB  
03202 Vilnius  
T +370 5 2136495  
mail@wilo.lt

### Morocco

WILO Maroc SARL  
20250 Casablanca  
T +212 (0) 5 22 66 09 24  
contact@wilo.ma

### The Netherlands

WILO Nederland B.V.  
1551 NA Westzaan  
T +31 88 9456 000  
info@wilo.nl

### Norway

WILO Norge AS  
0975 Oslo  
T +47 22 804570  
wilo@wilo.no

### Poland

WILO Polska Sp. z o.o.  
5-506 Lesznowola  
T +48 22 7026161  
wilo@wilo.pl

### Portugal

Bombas Wilo-Salmson  
Sistemas Hidraulicos Lda.  
4475-330 Maia  
T +351 22 2080350  
bombas@wilo.pt

### Romania

WILO Romania s.r.l.  
077040 Com. Chiajna  
Jud. Ilfov  
T +40 21 3170164  
wilo@wilo.ro

### Russia

WILO Rus ooo  
123592 Moscow  
T +7 495 7810690  
wilo@wilo.ru

### Saudi Arabia

WILO Middle East KSA  
Riyadh 11465  
T +966 1 4624430  
wshoula@wataniaind.com

### Serbia and Montenegro

WILO Beograd d.o.o.  
11000 Beograd  
T +381 11 2851278  
office@wilo.rs

### Slovakia

WILO CS s.r.o., org. Zložka  
83106 Bratislava  
T +421 2 33014511  
info@wilo.sk

### Slovenia

WILO Adriatic d.o.o.  
1000 Ljubljana  
T +386 1 5838130  
wilo.adriatic@wilo.si

### South Africa

Wilo Pumps SA Pty LTD  
1685 Midrand  
T +27 11 6082780  
patrick.hulley@salmson.co.za

### Spain

WILO Ibérica S.A.  
8806 Alcalá de Henares  
(Madrid)  
T +34 91 8797100  
wilo.iberica@wilo.es

### Sweden

WILO NORDIC AB  
35033 Växjö  
T +46 470 727600  
wilo@wilo.se

### Switzerland

Wilo Schweiz AG  
4310 Rheinfelden  
T +41 61 836 80 20  
info@wilo.ch

### Taiwan

WILO Taiwan CO., Ltd.  
24159 New Taipei City  
T +886 2 2999 8676  
nelson.wu@wilo.com.tw

### Turkey

WILO Pompa Sistemleri  
San. ve Tic. A.Ş.  
34956 İstanbul  
T +90 216 2509400  
wilo@wilo.com.tr

### Ukraine

WILO Ukraina t.o.w.  
08130 Kiev  
T +38 044 3937384  
wilo@wilo.ua

### United Arab Emirates

WILO Middle East FZE  
Jebel Ali Free zone – South  
PO Box 262720 Dubai  
T +971 4 880 9177  
info@wilo.ae

### USA

WILO USA LLC  
Rosemont, IL 60018  
T +1 866 945 6872  
info@wilo-usa.com

### Vietnam

WILO Vietnam Co Ltd.  
Ho Chi Minh City, Vietnam  
T +84 8 38109975  
nkminh@wilo.vn

# wilo

Pioneering for You

WILO SE  
Nortkirchenstr. 100  
44263 Dortmund  
Germany  
T +49 (0)231 4102-0  
T +49 (0)231 4102-7363  
wilo@wilo.com  
www.wilo.com