

## Wilo HHV-Z

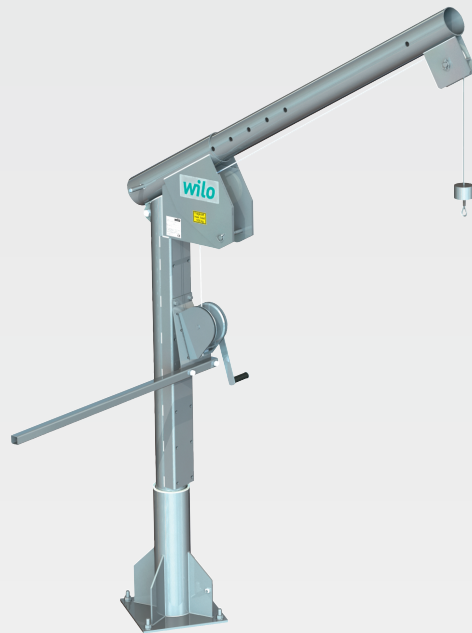

**en-US** Installation and operating instructions



Wilo HHV-Z  
<https://qr.wilo.com/2002>

## Table of contents

<b>1</b>	<b>General</b> .....	<b>4</b>
1.1	About this manual .....	4
1.2	Copyright .....	4
1.3	Subject to changes .....	4
1.4	Exclusion from warranty and liability .....	4
<b>2</b>	<b>Safety</b> .....	<b>4</b>
2.1	Personnel qualifications.....	4
2.2	Personal protective equipment .....	4
2.3	Fluids hazardous to health .....	5
2.4	Use in hazardous areas.....	5
2.5	Transport.....	5
2.6	Installation and dismantling work .....	5
2.7	During operation.....	5
2.8	Operator's obligations.....	5
<b>3</b>	<b>Transport and storage</b> .....	<b>5</b>
3.1	Delivery.....	5
3.2	Transport.....	5
3.3	Storage .....	6
<b>4</b>	<b>Application/Use</b> .....	<b>6</b>
4.1	Intended use.....	6
4.2	Improper use.....	6
<b>5</b>	<b>Product description</b> .....	<b>6</b>
5.1	Design.....	7
5.2	Technical data .....	7
5.3	Type key.....	8
5.4	Maximum bearing capacity depending on the projection .....	8
5.5	Scope of delivery.....	8
5.6	Accessories .....	8
<b>6</b>	<b>Installation</b> .....	<b>9</b>
6.1	Personnel qualifications.....	9
6.2	Operator's obligations.....	9
6.3	Installing the auxiliary lifting equipment.....	9
<b>7</b>	<b>Commissioning</b> .....	<b>16</b>
7.1	Personnel qualifications.....	16
7.2	Operator's obligations.....	16
7.3	Commissioning.....	17
7.4	During operation.....	17
<b>8</b>	<b>Decommissioning</b> .....	<b>17</b>
8.1	Personnel qualifications.....	17
8.2	Operator's obligations.....	17
8.3	Removal.....	17
<b>9</b>	<b>Maintenance and repair</b> .....	<b>19</b>
9.1	Personnel qualifications.....	19
9.2	Maintenance measures and maintenance intervals for the auxiliary lifting equipment.....	20
9.3	Maintenance measures and maintenance intervals for the manual cable winch .....	20
9.4	Definition of expert .....	20
<b>10</b>	<b>Faults, causes and remedies</b> .....	<b>20</b>

<b>11</b>	<b>Spare parts</b> .....	<b>20</b>
-----------	--------------------------	-----------

<b>12</b>	<b>Test protocol</b> .....	<b>21</b>
-----------	----------------------------	-----------

## 1 General

### 1.1 About this manual

These instructions form part of the product. Compliance with the instructions is essential for correct handling and use:

- Read the instructions carefully before all activities.
- Keep the instructions in an accessible place at all times.
- Observe all product specifications.
- Observe the markings on the product.

The language of the original operating instructions is German. All other languages of these instructions are translations of the original operating instructions.

### 1.2 Copyright

WILO SE © 2026

The reproduction, distribution and utilization of this document as well as the communication of its contents to others without express authorization is prohibited. Offenders will be held liable for the payment of damages. All rights reserved.

### 1.3 Subject to changes

Wilo shall reserve the right to change the listed data without notice and shall not be liable for technical inaccuracies and/or omissions. The illustrations used may differ from the original and are intended as a sample representation of the device.

### 1.4 Exclusion from warranty and liability

Wilo shall specifically not assume any warranty or liability in the following cases:

- Inadequate configuration due to inadequate or incorrect instructions by the operator or the client
- Non-compliance with these instructions
- Improper use
- Improper storage or transport
- Incorrect installation or dismantling
- Insufficient or incorrect maintenance
- Unauthorized repairs
- Inadequate installation site
- Chemical, electrical, or electrochemical influences
- Wear

## 2 Safety

This section contains basic information for the individual phases of the life cycle. Failure to observe this information leads to:

- Danger to persons
- Danger to the environment
- Property damage
- Loss of claims for damages

### 2.1 Personnel qualifications

- Staff have been instructed on the locally applicable provisions for accident prevention.
- Staff have read and understood the installation and operating instructions.
- Installation/dismantling work: trained sewage technology professional  
Fastening components to concrete and steel structures, handling the necessary fastening materials, working in hazardous areas
- Lifting work: trained professional for operating lifting devices  
Lifting equipment, lifting gear, attachment points
- Maintenance work: trained expert for the maintenance of lifting equipment  
Basic knowledge on the assessment and maintenance of lifting accessories, manual winches, and lifting slings

#### Restrictions on use due to age or limited abilities

- Persons under the age of 16: Working on or with the product is prohibited.
- Persons under the age of 18: Working on or with the product is permitted under supervision (supervisor).
- Persons with limited physical, sensory, or mental abilities: Working on or with the product is prohibited.

### 2.2 Personal protective equipment

The protective equipment specified is the minimum requirement. Observe the requirements in the work regulations.

- Safety shoes: Protection class S1 (uvex 1 sport S1)
- Protective gloves (EN 388): 4X42C (uvex C500 wet)
- Protective helmet (EN 397): Conforms to standards, protection against lateral deformation (uvex pheos)

The branded products in the parentheses constitute non-binding suggestions. Similar products from other brands can also be used. Adherence to the standards mentioned is required.

WILO SE does not assume any liability for the adherence of the aforementioned products to the corresponding standards.

- 2.3 Fluids hazardous to health**
- During operation, the wire rope comes into contact with sewage. Through the lifting motion, sewage spreads over the deflection pulleys and the manual cable winch. Contact with harmful germs may occur. Therefore, there is a danger of bacterial infections!
- If necessary, also wear the following protective equipment:
    - Safety goggles (EN 166): (uvex skyguard NT)
    - Breathing protection mask (EN 149): Half mask 3M series 6000 with filter 6055 A2
    - Observe the factory regulations.
  - Clean and disinfect the product thoroughly before dismantling.
  - Inform all persons about the fluid and the danger it poses!
- 2.4 Use in hazardous areas**
- The auxiliary lifting equipment has no mechanical explosion protection.
  - Spark formation **cannot** be ruled out.
- DANGER! Risk of explosion due to sparks! Use in hazardous areas is prohibited.**
- 2.5 Transport**
- The single components of the auxiliary lifting equipment are delivered pre-assembled on a pallet. Dismantle the individual components before transport.
  - The individual components weigh up to 60 kg (132 lbs.) and are longer than 1.5 m (5 ft). It takes two people to transport the individual components.
- WARNING! Risk of injury due to excessive weight. The fully assembled auxiliary lifting equipment is too heavy to transport. Always dismantle the auxiliary lifting equipment before transport.**
- 2.6 Installation and dismantling work**
- Observe the laws and regulations on workplace safety and accident prevention in force at the site.
  - Secure and demarcate the working area.
  - Unauthorized persons must be kept away from the working area.
  - Keep working area free of ice.
  - Keep the working area free from any objects lying around.
  - Work must always be carried out by two persons.
- 2.7 During operation**
- Only use lifting accessories that are in proper working condition.
  - Check the brake function of the manual cable winch before each use.
  - Attach the wire rope to the product using legally approved lifting slings (e.g. shackles).
- CAUTION! Do not use the wire rope directly as a lifting sling.**
- Always attach the lifting slings to the slinging points of the product.
  - Do not block the product when raising or lowering it.
  - Do not exceed the maximum bearing capacity of the auxiliary lifting equipment.
  - If it is no longer safe to use the auxiliary lifting equipment due to weather conditions, stop work immediately.
  - Do not stand underneath suspended loads.
  - Keep people away from the swivel area.
- 2.8 Operator's obligations**
- Provide the installation and operating instructions for the auxiliary lifting equipment and the manual cable winch in a language staff understands.
  - Make sure staff has received the required training for the specified work.
  - Provide the required protective equipment and ensure that the personnel wear the protective equipment.
  - Ensure that safety and information signs mounted on the device are always legible.
  - Train staff on how the system functions.
- 3 Transport and storage**
- 3.1 Delivery**
- Following receipt of the shipment the shipment must be immediately checked for defects (damage, completeness). Any existing defects must be noted on the freight documentation! Furthermore, the defects must be reported to the transport company or manufacturer on the date of receipt. Claims reported after this date can no longer be invoked.

### 3.2 Transport

## WARNING



### Risk of injury due to excessive weight!

The fully assembled auxiliary lifting equipment is too heavy to transport.

- Always dismantle the auxiliary lifting equipment before transport.

### 3.3 Storage

- The single components of the auxiliary lifting equipment are delivered pre-assembled on a pallet. Dismantle the individual components before transport.
- The individual components weigh up to 60 kg (132 lbs.) and are longer than 1.5 m (5 ft). It takes two people to transport the individual components.
- Dismantle the auxiliary lifting equipment before storage.
- Place the individual components horizontally on a pallet.
- Roll up the wire rope and secure it to the hand winch.
- Pack the manual cable winch to protect it from dirt and deposits.
- Maximum storage temperatures:
  - Auxiliary lifting equipment: -10 to 40 °C (14 to 104 °F), maximum humidity: 90%, non-condensing.
  - Mortar cartridge: 5 to 25 °C (41 to 77 °F), maximum humidity: 50%, non-condensing. Protect from daylight and direct exposure to sunlight.
- Recommended max. fluid temperature: 10 to 25 °C (50 to 77 °F), max. air humidity: 40 to 50 %.
- Do not carry out any welding work in the storage rooms. The resulting gases or radiation can affect the material's characteristics.
- Stainless steel components and plain steel components must be stored separately. Ferritic and austenitic stainless steels should be stored separately, according to the type.
- Prevent flash rust (e.g. dust from air-borne iron particles, diesel emissions).
- After storage, clean the components and check for damage.
- Do not use damaged components. Contact customer service.
- Damage can reduce the bearing capacity of the component.

## 4 Application/Use

### 4.1 Intended use

- Only for use in the corresponding holding sleeve. For flexible use, fit a corresponding holding sleeve for each site.
- Draining and lifting pumps and submersible mixers.
- Attach the wire rope to the product using a shackle.

### 4.2 Improper use

- Lowering and lifting other devices.
- Transporting people in any way.
- No mechanical drive of the manual cable winch.
- No continuous operation of the manual cable winch.
- Do not attach the wire rope directly to the product.

Any other use is considered improper. Intended use also includes observance of these instructions.

## 5 Product description

### 5.1 Design



Fig. 1: Variant overview

The auxiliary lifting equipment consists of the lifting equipment and a holding sleeve.

#### Holding sleeve

The holding sleeve is the pedestal of the auxiliary lifting equipment. The integrated floor bearing enables a swiveling range of 360°. The holding sleeve is available in two versions:

- For wall fixation
- For ground installation

#### Lifting equipment

The disassemblable lifting equipment consists of several components:

- Standpipe with manual cable winch and swivel lever.
- Holder for the boom.
- Boom with deflection pulley. A rope safety device on the deflection pulley ensures safe rope guidance.
- Up to two additional booms for a maximum projection of 3.20 m (10.5 feet). The booms are assembled in a telescopic configuration.

The auxiliary lifting equipment has a maximum bearing capacity of 250 to 500 kg (550 to 1100 lbs.), depending on the projection.

### 5.2 Technical data

<b>Lifting equipment</b>	
Bearing capacity	See rating plate
Operating/ambient temperature	-10 to 40 °C (14 to 104 °F)
Storage temperature	-10 to 40 °C (14 to 104 °F)
Material	Stainless steel 1.4301/1.4571 (AISI 304/316Ti)
<b>Mortar cartridge</b>	
Ambient temperature	-40 to 50 °C (-40 to 122 °F)
Installation temperature (substrate, cartridge, anchor rod)	-10 to 40 °C (14 to 104 °F)
Storage temperature	5 to 25 °C (41 to 77 °F)
<b>Manual cable winch</b>	
Manufacturer	Pfaff silver blue or Haakon
Material	Aluminum or stainless steel
<b>Wire rope</b>	
Version	7×19 DIN 3060/EN 12385

Diameter	6 mm (0.25 in)
Length	12 m (39 ft)
Material	Stainless steel 1.4401 (AISI 316)

### 5.3 Type key

Example: Wilo-HHV-ZT1-E/AH-2100-350kg	
HHV-Z	Auxiliary lifting equipment, dismantlable
T1	Number of additional booms
E	Lifting equipment material: Stainless steel
AH	Manual cable winch material: <ul style="list-style-type: none"> <li>• AH = Aluminum</li> <li>• EH = Stainless steel</li> </ul>
2100	Maximum projection
350 kg (771 lbs.)	Maximum bearing capacity at maximum projection

### 5.4 Maximum bearing capacity depending on the projection

Projection	Maximum bearing capacity with specified projection			
	HHV Z- E/ ... -1600-500kg	HHV ZT1- E/ ... -2100-350kg	HHV ZT1- E/ ... -3200-250kg	HHV ZT2- E/ ... -3200-250kg
3200 mm (126 in)	–	–	250 kg (551 lbs.)	250 kg (551 lbs.)
3100 mm (122 in)	–	–	262 kg (578 lbs.)	260 kg (573 lbs.)
3000 mm (118 in)	–	–	275 kg (606 lbs.)	270 kg (595 lbs.)
2900 mm (114 in)	–	–	–	280 kg (617 lbs.)
2800 mm (110 in)	–	–	300 kg (661 lbs.)	–
2700 mm (106 in)	–	–	–	300 kg (661 lbs.)
2600 mm (102 in)	–	–	325 kg (717 lbs.)	–
2500 mm (98 in)	–	–	–	330 kg (728 lbs.)
2400 mm (94 in)	–	–	350 kg (772 lbs.)	–
2300 mm (91 in)	–	–	–	360 kg (794 lbs.)
2200 mm (87 in)	–	–	375 kg (827 lbs.)	–
2100 mm (83 in)	–	350 kg (772 lbs.)	–	390 kg (860 lbs.)
2000 mm (79 in)	–	375 kg (827 lbs.)	400 kg (882 lbs.)	–
1900 mm (75 in)	–	400 kg (882 lbs.)	–	420 kg (926 lbs.)
1800 mm (71 in)	–	425 kg (937 lbs.)	–	–
1700 mm (67 in)	–	450 kg (992 lbs.)	–	–
1600 to 1300 mm (63 to 51 in)	500 kg (1102 lbs.)	500 kg (1102 lbs.)	–	–
1300 to 800 mm (51 to 31 in)	500 kg (1102 lbs.)	–	–	–

#### Key

– = Projection not adjustable

### 5.5 Scope of delivery

- Standpipe with attached manual cable winch, swivel lever, and wire rope
- Boom support
- Boom with deflection pulley
- Up to two additional booms (HHV-ZT1 and HHV-ZT2)
- Holding sleeve
- Installation and operating instructions

### 5.6 Accessories

- Catch hook
- Catch device with guide element
- Wire rope bollard for fixation of the lifting cable

## 6 Installation

### 6.1 Personnel qualifications

- Electrical work: qualified electrician  
Someone with suitable technical training, knowledge and experience who can identify and avoid the dangers associated with electricity.
- Installation/dismantling work: trained sewage technology professional  
Fastening components to concrete and steel structures, handling the necessary fastening materials, working in hazardous areas

### 6.2 Operator's obligations

- Observe locally applicable accident prevention and safety regulations.
- Provide protective equipment. Ensure that personnel wear the protective equipment.
- Demarcate the working area.
- Unauthorized persons must be kept away from the working area.
- If the weather conditions (e.g. ice formation, strong wind) mean it is no longer possible to work safely, stop all work.
- To allow the product to be fixed securely and functionally, the structural components and foundations must be of sufficient stability. The operator is responsible for the provision and suitability of the structural components and foundations!
- Check that the available consulting documents (installation plans, installation site, in-flow conditions) are complete and correct.

### 6.3 Installing the auxiliary lifting equipment

#### DANGER



#### **Danger due to contact with fluids which are hazardous to health during installation!**

Danger of bacterial infection!

- Clean and disinfect the installation site.
- Wipe up drips immediately.
- Observe information from the work regulations!
- If contact with fluids that are hazardous to health is possible, wear the following protective equipment:
  - Closed safety goggles
  - Face mask
  - Protective gloves

#### DANGER



#### **Risk of fatal injury due to dangerous lone working practices!**

Working in pump chambers and tight spaces as well as working where there is a danger of falling is dangerous work. This work must not be carried out alone!

- Only carry out work with another person!

#### CAUTION

#### **Material damage due to incorrect fixation**

Incorrect fixation can impair the function of the auxiliary lifting equipment and damage the structure.

- If the mixer is fixed to a concrete structure, use anchor bolts for fixation. Follow the manufacturer's installation instructions! Temperature specifications and hardening periods must be strictly observed.
  - If the mixer is fixed to a steel structure, ensure that the structure is sufficiently strong. Use fixation materials with sufficient strength! Use suitable materials to prevent electrochemical corrosion!
  - Tighten all screwed connections. Observe torque specifications.
- 
- Wear protective equipment! Observe the work regulations.
    - Protective gloves: 4X42C (uvex C500 wet)

- Safety shoes: Protection class S1 (uvex 1 sport S1)
- Wear a safety harness where required!
- Wear a safety helmet (EN 397 Conforms to standards, protection against lateral deformation (uvex pheos))! Observe the work regulations.
- Prepare installation site:
  - Clean, free of coarse solids
  - Dry
  - Frost-free
  - Disinfected

### 6.3.1 Installation instructions for bonded anchors

## WARNING



### Warning of irritants

The mortar cartridges contain the following chemical substances: dibenzoyl peroxide, dicyclohexyl phthalate, 2-hydroxypropyl methacrylate, 1,4-butanediol dimethacrylate. These substances are “irritants”. Observe the following points:

- May cause allergic skin reactions.
  - May harm an unborn child.
  - Toxic to aquatic organisms, with long lasting effects.
  - Do not get in eyes, on skin, or on clothing.
  - Wear suitable protective clothing: safety glasses, safety gloves, etc.
  - In case of contact with eyes: Rinse gently with water for a few minutes. Remove any contact lenses if possible. Continue rinsing.
  - In case of contact with skin, rinse off with plenty of soap and water.
  - If eye irritation, skin irritation, or skin rash persists, consult a doctor immediately.
- 
- Concrete quality:
    - Normal concrete
    - Torn or cracked
    - Reinforced or unreinforced
    - Strength class: C20/25 to C50/60 (according to EN 206-1)
  - Temperature data:
    - Ambient temperature: –40 to 50 °C (–40 to 122 °F)
    - Installation temperature (substrate, cartridge, anchor rod): –10 to 40 °C (14 to 104 °F)
  - The anchoring base is dry.
  - Do not use defective or old mortar cartridges (see expiry date).
  - Do not load the anchor rod until the curing time has elapsed.

### 6.3.2 Assembling the holding sleeve

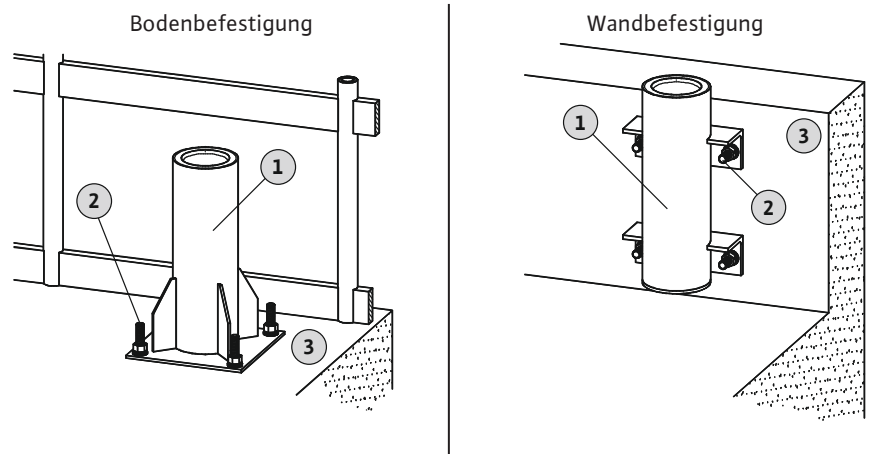

Fig. 2: Holding sleeve – floor fixation

1	Holding sleeve
2	Fastening with bonded anchor
3	Building

- ✓ Check the fixation location of the holding sleeve. The holding sleeve must rest flush against the structure. Do not compensate for unevenness using loose metal sheets – rework the structure.
  - ✓ Assembly instructions for the bonded anchors are read and understood.
1. Align the holding sleeve vertically at the edge of the basin.
  2. Mark the boreholes. Observe the edge and hole spacing according to the assembly instructions for the bonded anchors. If the distances are not maintained, attach additional on-site mounting brackets.
  3. Position the bonded anchors according to the manufacturer's assembly instructions.  
⇒ Observe the curing time!
  4. Place the holding sleeve on the anchor rods.
  5. Fix the holding sleeve in place using disks and hexagon nuts. Observe the maximum tightening torque.

**NOTICE! Secure the hexagon nuts with a high-strength screw locking device (e.g. Loctite 2701).**

#### Tightening torques for anchor rod HAS-U, HIS-N, and HIS-RN with mortar cartridge HVU2

Thread	Tightening torque		
	Nm*	kp m	ft-lb
M8	≤10	≤1	≤7.4
M10	≤20	≤2	≤14.8
M12	≤40	≤4	≤29.5
M16	≤80	≤8.2	≤59
M20	≤150	≤15.3	≤110.6

\* Data according to manufacturer's instructions 2169263, V17-07.2025.

6.3.3 Installing the lifting equipment

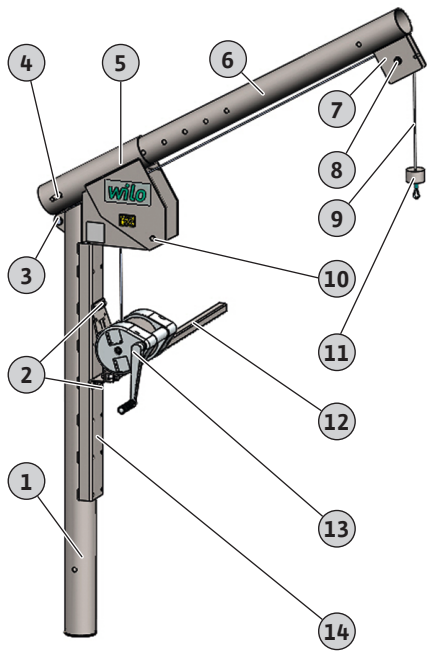

Fig. 3: Overview of components

1	Standpipe
2	Hand winch fixation
3	Secure the fastening bolt with two linchpins to secure the boom support
4	Locking bolt of 1st boom
4a	Locking bolt of 2nd boom
4b	Locking bolt of 3rd boom
5	Boom support
6	1st boom
6a	2nd boom
6b	3rd boom
7	Wire rope and deflection pulley
8	Fastening bolt for deflection pulley
9	Wire rope
10	Fastening bolt for boom support
11	Rope mass
12	Swivel lever
13	Manual cable winch
14	Manual cable winch support
15	Holding sleeve

**WARNING**



**Risk of injury to head, hands, or feet!**

There is a danger of (serious) injury from crushing and impact during installation and dismantling.

- Wear protective equipment.
- Always work in pairs.
- Work carefully and with foresight.
- Cordon off the working area.
- Ensure there is sufficient clearance in the handling area. Do not place the individual components directly in the handling area.

**Installing the standpipe**

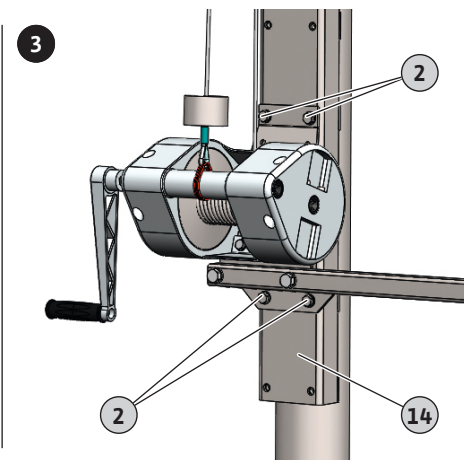
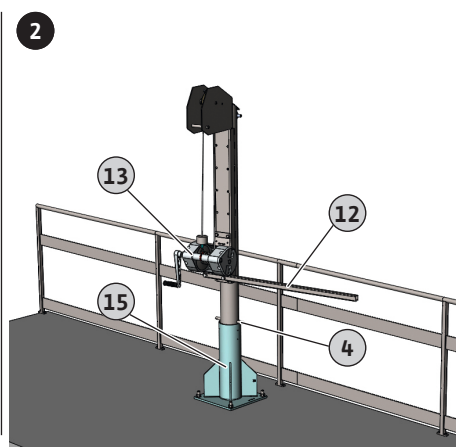
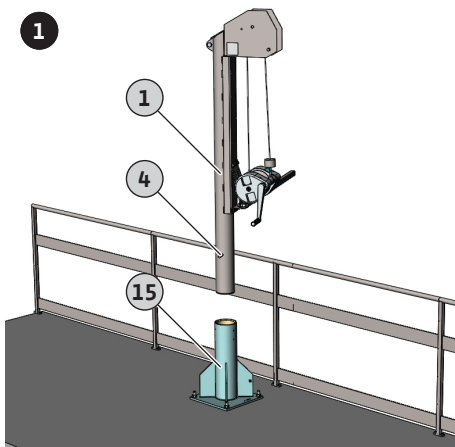

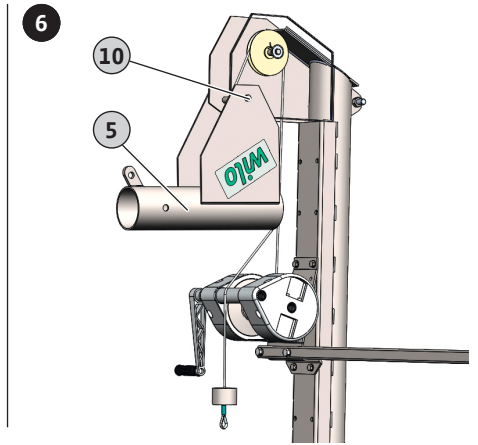
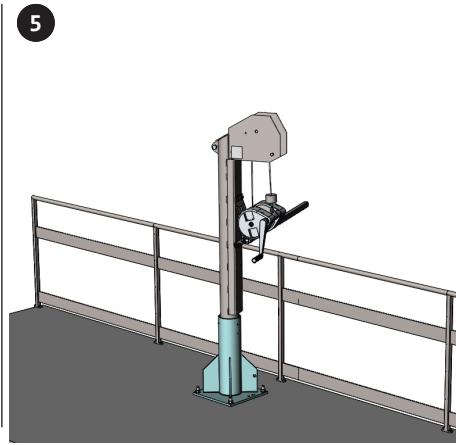
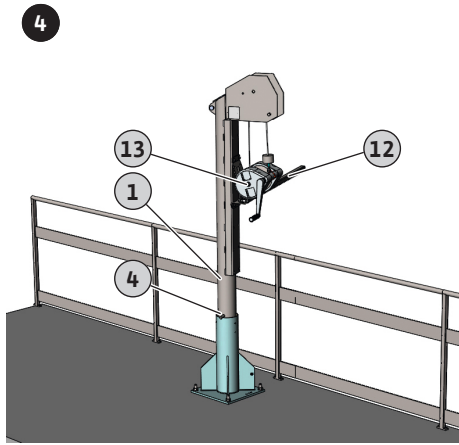

- ✓ The auxiliary lifting equipment is partially installed. Disassemble all components and check for completeness and damage.
  - ✓ Determine projection. The wire rope must run vertically from the pulley to the product.
  - ✓ Clean the shaft of the holding sleeves. Dirt damages the plain bearing and impairs the rotary function of the auxiliary lifting equipment.
1. Insert the locking bolt for the 1st boom into the drilled hole on the standpipe. Secure the locking bolt with a cotter pin.
  2. Lift the standpipe by the swivel lever and the manual cable winch and insert it into the pre-assembled holding sleeve.  
→ The standpipe sits with the locking bolt on the holding sleeve.
  3. Adjust the height of the manual cable winch (approx. 1.40 m/4.6 ft): Loosen the hex screws for fastening the manual cable winch. Set the manual cable winch to the desired height. Reattach the manual cable winch with the hex screws. **Torque: 57 Nm.**  
**CAUTION! During installation or dismantling, the standpipe is lifted on the swivel lever and the manual cable winch. Observe the tightening torque for fastening the manual cable winch.**
  4. Lift the standpipe by the swivel lever. Remove the locking bolt. Insert the standpipe completely into the holding sleeve.
  5. Check the swivel range. If the required swiveling range is not possible, adjust the height of the manual cable winch (see step 3).  
▶ The standpipe is installed.

#### Installing the boom(s)

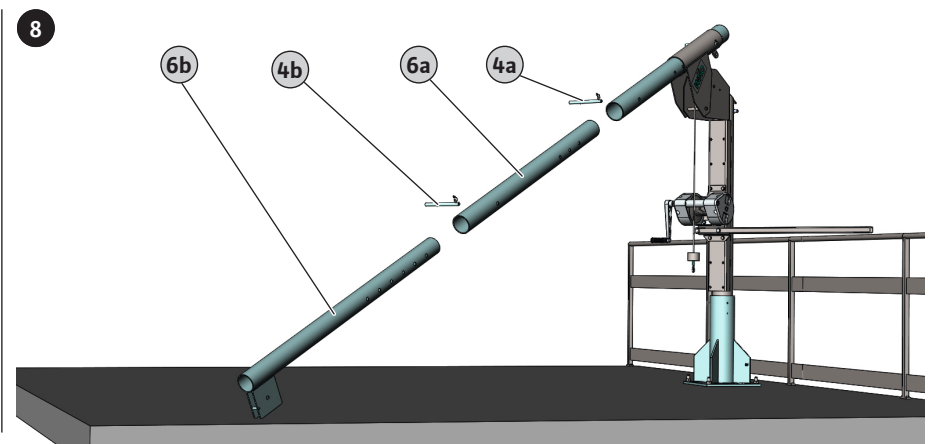
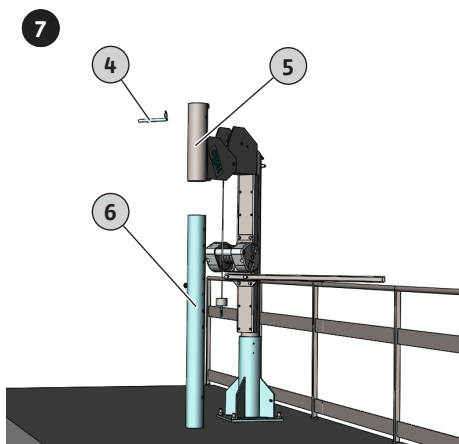

- ✓ The standpipe is installed.
  - ✓ The swivel range is checked.
1. Fix the boom support to the standpipe using the fastening bolt.  
**NOTICE! Guide the wire rope past the fastening bolt.**
  2. Secure the fastening bolt on both sides with a cotter pin.

3. Align the boom support vertically. Insert the boom into the boom support from below. Set the desired projection and secure the boom with the locking bolt.  
**WARNING! Risk of injury. Do not simply let go of the boom. Due to its net weight, the boom swings against the standpipe or the manual cable winch when released. Slowly bring the boom into the rest position by hand.**
  4. Secure the locking bolt with a cotter pin.
  5. **Auxiliary lifting equipment HHV-ZT ...:** For these variants, install the individual booms one after the other in a telescopic configuration. The individual booms are labeled accordingly (1, 2, 3). Always start with the 1st boom.
    - Install the 1st boom as described under point 2.
    - Align the 1st boom at an angle. Insert 2nd boom into the 1st boom. Adjust the projection and secure the 2nd boom with the locking bolt.
    - Secure the locking bolt with a cotter pin.
    - Proceed with the 3rd boom in the same way as with the 2nd boom.
- Boom mounted, projection adjusted.

#### Attaching the wire rope and installing the boom on the standpipe

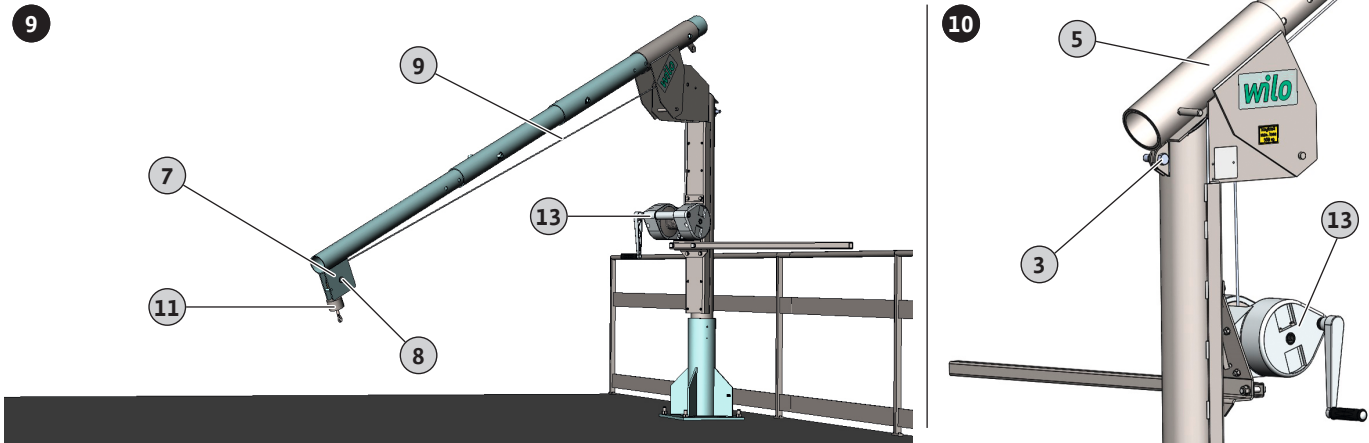

- ✓ The boom(s) is/are installed.
  - ✓ Adjust projection.
1. Unwind the wire rope from the manual cable winch according to the radius.
  2. Remove the deflection pulley: loosen a cotter pin from the fastening bolt of the deflection pulley. Pull out the fastening bolt and remove the deflection pulley.
  3. Place the wire rope on the deflection pulley.
  4. Push the deflection pulley back between the two strips.
  5. Fix the deflection pulley using the fastening bolt. Secure the fastening bolt with a cotter pin.
  6. Check the following points:
    - The standpipe is fully placed in the holding sleeve.
    - Components are correctly installed and secured with bolts.
    - Bolts are secured with spring cotter pins and cannot come loose.
    - The height of the manual cable winch is correctly adjusted and secured.
    - The wire rope is correctly attached.
- ⇒ **DANGER! Danger of death due to improper installation. If the individual components are not installed correctly, there is a danger of death. Carry out all further steps only after correct installation.**
7. Slowly wind up the wire rope with the manual cable winch until the rope mass touches the deflection pulley.
  8. To bring the boom into its target position, continue to slowly wind up the wire rope.
  9. Continue cranking with the manual cable winch until the boom support is completely in contact with the standpipe.
  10. Fix the boom support to the standpipe using the fastening bolt.
  11. Secure the fastening bolts with the two linchpins.
  12. Lower the wire rope approx. 20 cm (8 in).
    - Lifting equipment fully installed.

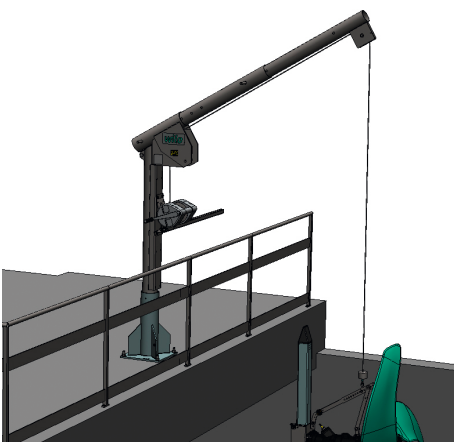

- 6.3.4 Grounding lifting equipment** Ground the auxiliary lifting equipment in accordance with the regulations. Connect the protective ground conductor to the drilled hole or ground terminal (⊕) using a suitable screw, nut, and tooth lock washer. The cross section of the cable for the protective ground conductor must comply with the local regulations.
- 6.3.5 Using auxiliary lifting equipment at several sites** The auxiliary lifting equipment is designed to be mobile and can be used at several sites. The following points are a prerequisite for this:
- One holding sleeve per site  
The holding sleeve must be firmly connected to the structure. Mobile use of the holding sleeve is therefore not possible. A holding sleeve must be firmly attached to the structure at each site. To protect the plain bearing from dirt and damage, seal the shaft of a free-standing holding sleeve so that it is watertight.
  - Provide a wire rope bollard to wrap and secure the wire rope.
    - For mobile use of the auxiliary lifting equipment, unwind the wire rope from the manual cable winch after use.
    - The wire rope bollard is used to wrap and secure the wire rope.
    - Attach the wire rope bollard to the structure in the immediate vicinity of the holding sleeve.
    - Place the wire rope on the manual cable winch again the next time it is used. **NOTICE! Refer to the wire rope manufacturer's installation and operating instructions for information on installing the wire rope.**
- 6.3.6 Checking wire rope length** In the lowest lowering position, three or more cable windings must remain on the winch drum. If there are fewer than three turns of rope, attach a sufficiently long wire rope.
- ✓ Auxiliary lifting equipment fully installed.
  - 1. Turn the boom over the basin.
  - 2. Lower the wire rope via the manual cable winch to the lowest duty point of the submersible mixer or the pump.
  - 3. Check the cable windings on the manual cable winch:
    - There are three or more cable windings on the manual cable winch. Wire rope length in order. Rewind the wire rope.
    - There are less than three rope windings on the manual cable winch. Wire rope length too short. Replace with a longer wire rope.
    - ▶ Wire rope length checked.
- NOTICE! To install a new wire rope, follow the winch manufacturer's installation and operating instructions.**
- 6.3.7 Adjusting the height of the manual cable winch**
- ✓ Wire rope unburdened. There are no objects attached to the wire rope.
  - 1. Lower the wire rope approx. 50 cm (20 in).
  - 2. Loosen the hex screws for fastening the manual cable winch.
  - 3. Set the manual cable winch to the desired height.
  - 4. Fasten the manual cable winch using the hex screws. **Torque: 57 Nm.**  
**CAUTION! During installation or dismantling, the standpipe is lifted on the swivel lever and the manual cable winch. Observe the tightening torque for fastening the manual cable winch.**
  - 5. Check the swivel range. If the required swiveling range is not possible, adjust the height of the manual cable winch.
    - ▶ Height of the manual cable winch adjusted.

## 6.3.8 Checking the wire rope alignment

**WARNING****Risk of injury to head, hands, or feet!**

There is a danger of (serious) injury from crushing and impact during installation and dismantling.

- Wear protective equipment.
- Always work in pairs.
- Work carefully and with foresight.
- Cordon off the working area.
- Ensure there is sufficient clearance in the handling area. Do not place the individual components directly in the handling area.

To warrant optimum power transmission when lifting and lowering, the wire rope must run vertically from the deflection pulley to the slinging point. If necessary, adjust the position of the deflection pulley using the projection.

- ✓ Wire rope unburdened. There are no objects attached to the wire rope.
  - ✓ Only adjust the projection when the boom is resting on the ground.
1. Swivel the boom over the working area.
  2. Slowly wind up the wire rope with the manual cable winch until the rope mass touches the deflection pulley.
  3. Detach the boom support from the standpipe: pull out the linchpins and remove the fastening bolts.
  4. To lower the boom, slowly unwind the wire rope.
  5. Unwind the wire rope until the deflection pulley rests on the ground.  
⇒ The boom is prepared.
  6. Adjust the deflection pulley:
    - Remove the locking bolt of the corresponding boom.
    - Adjust the boom.
    - Fix the boom again with the locking bolt.
    - ⇒ Projection adjusted.
  7. Check the following points:
    - Booms are correctly installed and secured with bolts.
    - Bolts are secured with spring cotter pins and cannot come loose.
    - ⇒ **DANGER! Danger of death due to improper installation. If the individual booms are not installed correctly, there is a danger of death. Carry out all further steps only after correct installation.**
  8. Slowly wind up the wire rope with the manual cable winch until the rope mass touches the deflection pulley.
  9. To bring the boom into its target position, continue to slowly wind up the wire rope.
  10. Continue cranking with the manual cable winch until the boom support is completely in contact with the standpipe.
  11. Fix the boom support to the standpipe using the fastening bolt.
  12. Secure the fastening bolts with the two linchpins.
  13. Lower the wire rope approx. 20 cm (8 in).
    - ▶ Projection adjusted, the complete boom is reinstalled.

**7 Commissioning****7.1 Personnel qualifications**

- Lifting work: trained professional for operating lifting devices  
Lifting equipment, lifting gear, attachment points

**7.2 Operator's obligations**

- Provide the installation and operating instructions for the auxiliary lifting equipment and the manual cable winch in a language staff understands.
- Ensure that all personnel have read and understood the installation and operating instructions for the auxiliary lifting equipment and the manual cable winch.
- Unauthorized persons must be kept away from the working area.
- The swivel area is free of objects and accessible.

### 7.3 Commissioning

## DANGER



### Danger of death due to improper commissioning!

There is a danger of death in the event of improper or incorrect commissioning. Carry out the following points before each commissioning and document them in the test log:

- Check the fastening of the holding sleeve.
- Check the auxiliary lifting equipment fits in the holding sleeve.
- Visually inspect the holding sleeve and auxiliary lifting equipment for damage.
- All bolts are secured with a cotter pin.
- Check the swivel range.
- Check the brake function of the manual cable winch (see winch manufacturer's installation and operating instructions).
- Check the wire rope and lifting sling for damage.
- Check the weight of the load. The weight is below the maximum bearing capacity of the auxiliary lifting equipment.
- When using a wire rope bollard: correctly position the wire rope on the manual cable winch. Refer to the wire rope manufacturer's installation and operating instructions for information on installing the wire rope.

1. Attach the wire rope to the slinging point of the mixer or pump using an approved lifting sling (e.g. shackle).
2. Insert the hand crank into the manual cable winch until you hear the crank engage.
  - ▶ Depending on the direction of rotation of the hand crank, raise or lower the mixer or the pump.
 

**NOTICE! Only use the high-speed gear on the manual cable winch, if available, without a load (see the winch manufacturer's installation and operating instructions).**
  - ▶ Use the swivel lever to swivel the boom accordingly.

### 7.4 During operation

- Unauthorized persons must be kept away from the working area.
- The swivel area is free of objects and accessible.
- Never allow anyone to stand under suspended loads.

## 8 Decommissioning

### 8.1 Personnel qualifications

- Electrical work: qualified electrician  
Someone with suitable technical training, knowledge and experience who can identify and avoid the dangers associated with electricity.
- Installation/dismantling work: trained sewage technology professional  
Fastening components to concrete and steel structures, handling the necessary fastening materials, working in hazardous areas

### 8.2 Operator's obligations

- Observe locally applicable accident prevention and safety regulations.
- Provide protective equipment. Ensure that personnel wear the protective equipment.
- Demarcate the working area.
- Unauthorized persons must be kept away from the working area.
- If the weather conditions (e.g. ice formation, strong wind) mean it is no longer possible to work safely, stop all work.

**DANGER****Danger during removal due to fluids which are hazardous to health!**

Contact with fluids that are hazardous to health is possible during removal. Observe the following points:

- Wear protective equipment:
  - Closed safety goggles
  - Face mask
  - Protective gloves
- Wipe up drips immediately.
- Observe the specifications of the factory regulations!

**DANGER****Risk of fatal injury due to dangerous lone working practices!**

Working in pump chambers and tight spaces as well as working where there is a danger of falling is dangerous work. This work must not be carried out alone!

- Only carry out work with another person!

**WARNING****Risk of injury to head, hands, or feet!**

There is a danger of (serious) injury from crushing and impact during installation and dismantling.

- Wear protective equipment.
- Always work in pairs.
- Work carefully and with foresight.
- Cordon off the working area.
- Ensure there is sufficient clearance in the handling area. Do not place the individual components directly in the handling area.

- Wear protective equipment! Observe the work regulations.
  - Protective gloves: 4X42C (uvex C500 wet)
  - Safety shoes: Protection class S1 (uvex 1 sport S1)
  - Wear a safety harness where required!
  - Wear a safety helmet (EN 397 Conforms to standards, protection against lateral deformation (uvex pheos))! Observe the work regulations.

**Disassembling the auxiliary lifting equipment**

- ✓ A cleaning agent and disinfectants for cleaning the components are available.
  - ✓ A pallet is available for placing and later transporting the components.
  - ✓ Wire rope unburdened. There are no objects attached to the wire rope.
1. Swivel the boom over the working area.
  2. Slowly wind up the wire rope with the manual cable winch until the rope mass touches the deflection pulley.
  3. Detach the boom support from the standpipe: pull out the linchpins and remove the fastening bolts.
  4. To lower the boom, slowly unwind the wire rope.
  5. Unwind the wire rope until the deflection pulley rests on the ground.
  6. Reattach the fastening bolts to the standpipe with both linchpins.
    - ⇒ Prepare the boom for dismantling.

7. Remove the deflection pulley: loosen a cotter pin from the fastening bolt of the deflection pulley. Pull out the fastening bolt and remove the deflection pulley.
8. Remove the wire rope from the deflection pulley.
9. Push the deflection pulley back between the two strips.
10. Fix the deflection pulley using the fastening bolt. Secure the fastening bolt with a cotter pin.
11. Wind up the wire rope until the rope mass is just below the boom support.  
⇒ Wire rope removed.
12. Raise the boom by hand at an angle.
13. Release the locking bolt of the boom in the boom support and pull it out.
14. Secure the boom support by hand.
15. Pull the boom out of the boom support.  
**WARNING! Risk of injury. Do not simply let go of the boom support. Due to its net weight, the boom support swings against the standpipe or the manual cable winch when released. Slowly bring the boom support into the rest position by hand.**
16. Place the boom on the pallet.
17. Insert the locking bolt back into the boom and secure it with a cotter pin.  
⇒ The boom is disassembled.
18. **Auxiliary lifting equipment HHV-ZT ...:** for these variants, the individual booms should be disassembled one after the other. The individual booms are labeled accordingly (1, 2, 3). Always start with the 3rd boom.
  - Raise the boom by hand at an angle.
  - Loosen and pull out the locking bolt of the 3rd boom.
  - Secure the boom by hand at the 2nd boom.
  - Pull out the 3rd boom and place it on the pallet.
  - Loosen and remove the locking bolt of the 2nd boom.
  - Secure the boom by hand at the 1st boom.
  - Pull out the 2nd boom and place it on the pallet.
  - Loosen and pull out the locking bolt of the 1st boom at the boom support.
  - Secure the boom support by hand.
  - Pull out the 1st boom and place it on the pallet.  
**WARNING! Risk of injury. Do not simply let go of the boom support. Due to its net weight, the boom support swings against the standpipe or the manual cable winch when released. Slowly bring the boom support into the rest position by hand.**
  - Insert the locking bolts back into the booms and secure each with a cotter pin.  
⇒ The booms of the **auxiliary lifting equipment HHV-ZT ...** are disassembled.
19. Secure the boom support by hand.
20. Loosen and pull out the fastening bolt of the boom support.
21. Remove the boom support and place it on the pallet.
22. Reattach the fastening bolt to the boom support and secure on both sides with a cotter pin.  
⇒ The boom support is disassembled.
23. Secure the wire rope to the manual cable winch.
24. Lift the standpipe by the manual cable winch and the swivel lever and pull it out of the holding sleeve.
25. Place the standpipe on the pallet.  
⇒ Standpipe is disassembled.
26. Clean the holding sleeve and close the shaft so it is watertight.
27. Thoroughly clean and disinfect all components.
  - ▶ Auxiliary lifting equipment is completely disassembled and prepared for storage.

## 9 Maintenance and repair

### 9.1 Personnel qualifications

- Maintenance work: trained expert for the maintenance of lifting equipment  
Basic knowledge on the assessment and maintenance of lifting accessories, manual winches, and lifting slings

## 9.2 Maintenance measures and maintenance intervals for the auxiliary lifting equipment

### Quarterly (every three months)

- Check and maintain the wire rope for wear in accordance with DIN 15020, sheet 2.

### Annually (every twelve months)

- Inspection of the auxiliary lifting equipment by an expert:
  - Check all components of the auxiliary lifting equipment for wear and damage
  - Check the manual cable winch (crank, brake, gearbox etc.)

**NOTICE! Document all maintenance measures in the test log.**

## 9.3 Maintenance measures and maintenance intervals for the manual cable winch

Refer to the installation and operating instructions for the manual cable winch for all information on maintenance intervals and maintenance measures.

**NOTICE! Document all work in the test log.**

## 9.4 Definition of expert

Experts are individuals who have sufficient knowledge in the field of winches, lifting, and pulling equipment due to their professional training and experience. Furthermore, experts are familiar with the relevant national occupational health and safety regulations, accident prevention regulations, guidelines, and generally recognized technical rules. On this basis, experts can assess the occupational health and safety condition of winches, lifting, and pulling equipment.

## 10 Faults, causes and remedies

### Winch is difficult to crank when unburdened

1. Lubricant is missing.
  - ⇒ Carry out maintenance on the manual cable winch. Contact the winch manufacturer's customer service.

### Winch is difficult to crank when loaded

1. Crank is engaged in fast gear.
  - ⇒ Reengage the crank.
2. Winch is overloaded.
  - ⇒ Compare the maximum weight of the load with the maximum bearing capacity. Reduce load.

### Load is not held

1. Wire rope wound up incorrectly.
  - ⇒ Position the wire rope correctly (see winch manufacturer's installation and operating instructions).
2. Brake worn or defective.
  - ⇒ Carry out maintenance on the manual cable winch. Contact the winch manufacturer's customer service.

### Auxiliary lifting equipment can only be swiveled to a limited extent

1. There is an obstacle in the swivel range.
  - ⇒ Remove obstacle.
2. The holding sleeve shaft is dirty.
  - ⇒ Clean the shaft and counter bearing in the standpipe.
3. The plastic plain bearing is defective.
  - ⇒ Replace the plastic plain bearing.

### Further steps for troubleshooting

If the points listed here do not rectify the fault, contact customer service. Customer service can provide further assistance as follows:

- Support by telephone or in writing.
- On-site support.
- Inspection and repair at the factory.

Costs may be incurred for some services from customer service! Please contact customer service for more information.

## 11 Spare parts

Spare parts can be ordered from customer service. To avoid return queries and incorrect orders, the serial or article number must always be given. **Subject to change without prior notice!**



Name of inspector	Work carried out										Condition of the system	Date	Signature																																																																																																																																			
	Fastening of the holding sleeve														Seat of the auxiliary lifting device in the holding sleeve													Visual inspection of holding sleeve and auxiliary lifting device													All bolts secured with split pins													Check swivel range													Check braking function of the hand winch													Maintenance of the wire rope acc. to DIN 15020, sheet 2													Inspection by a qualified person (expert)													Maintenance work carried out on the hand winch													All right													Review required												





Pioneering for You

**WILO USA LLC**

Corporate Headquarters  
W66 N1253 Forward Way  
Cedarburg, WI 53012  
United States of America

T +1 262-204-6600  
info.us@wilo.com  
www.wilo-usa.com

**Wilo Canada Inc.**

Canada Headquarters  
Bay 8, 925 30th St. NE  
Calgary AB, T2A 5L7  
Canada

T +1 403-276-9456  
info@wilo-canada.com  
www.wilo-canada.com