

Wilo-Yonos GIGA2.0-I/-D/-B (0,37 ... 22 kW)



en Installation and operating instructions



Yonos GIGA2.0-I
<https://qr.wilo.com/276>



Yonos GIGA2.0-D
<https://qr.wilo.com/277>

Fig. I Yonos GIGA2.0-I/-D DN 32 ... DN 50 (0,37 ... 4,0 kW) / DN 65 ... DN 80 (0,37 ... 7,5 kW)

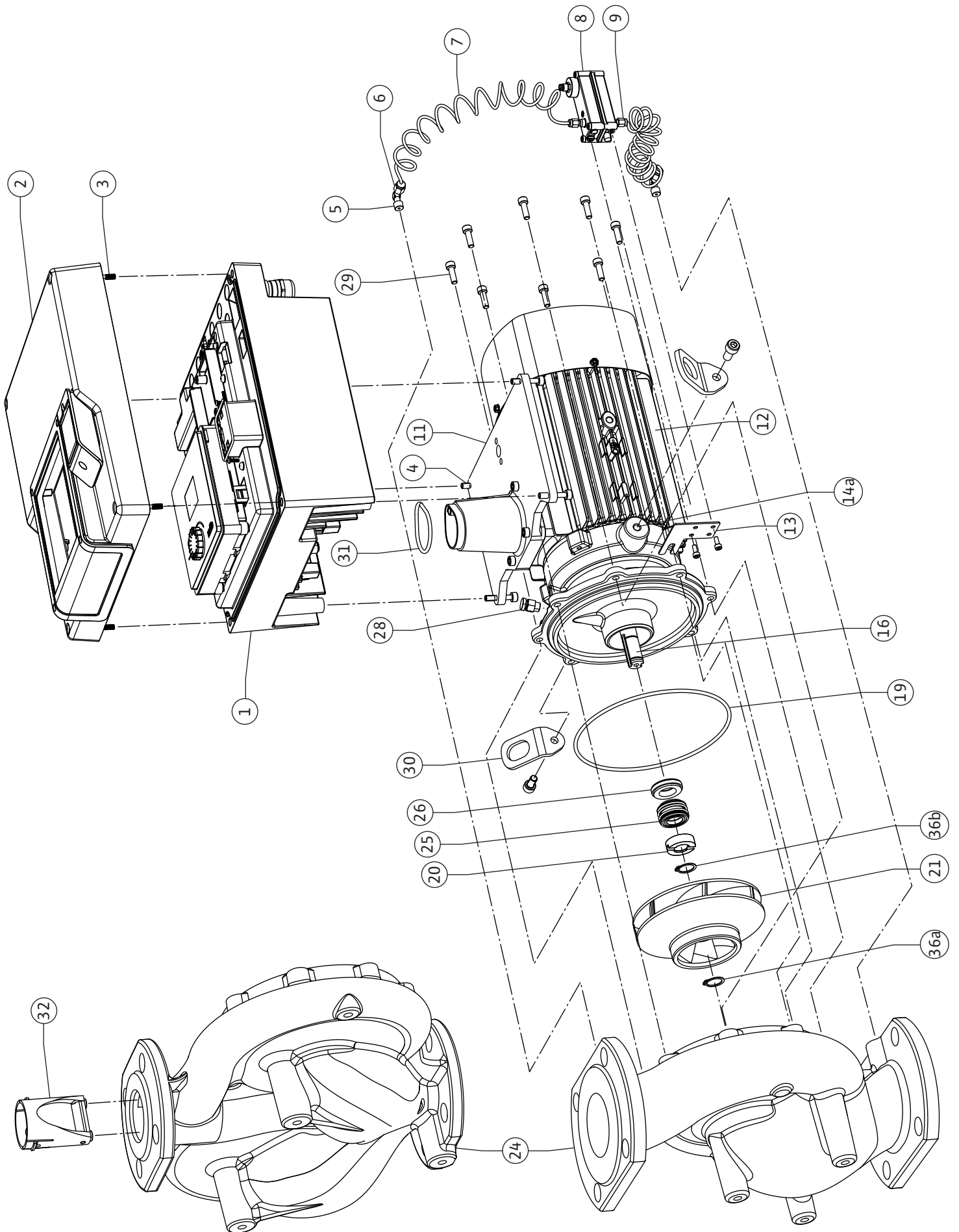

Fig. II: Yonos GIGA2.0-I / -D DN 100 ... DN 125 (2,2 ... 4 kW)

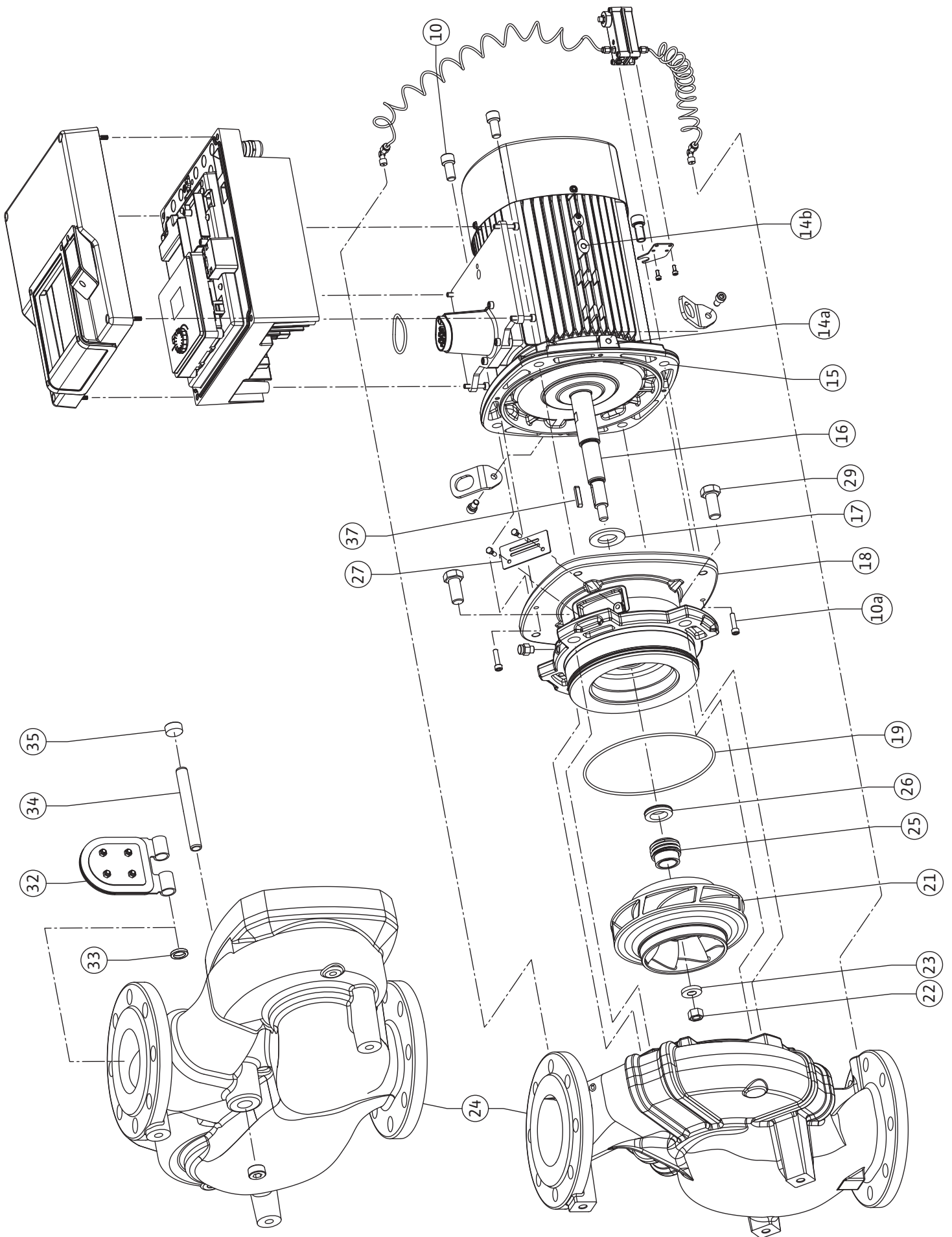

Fig. III: Yonos GIGA2.0-I/-D DN 40 ... DN 50 /DN 100 ... DN 150

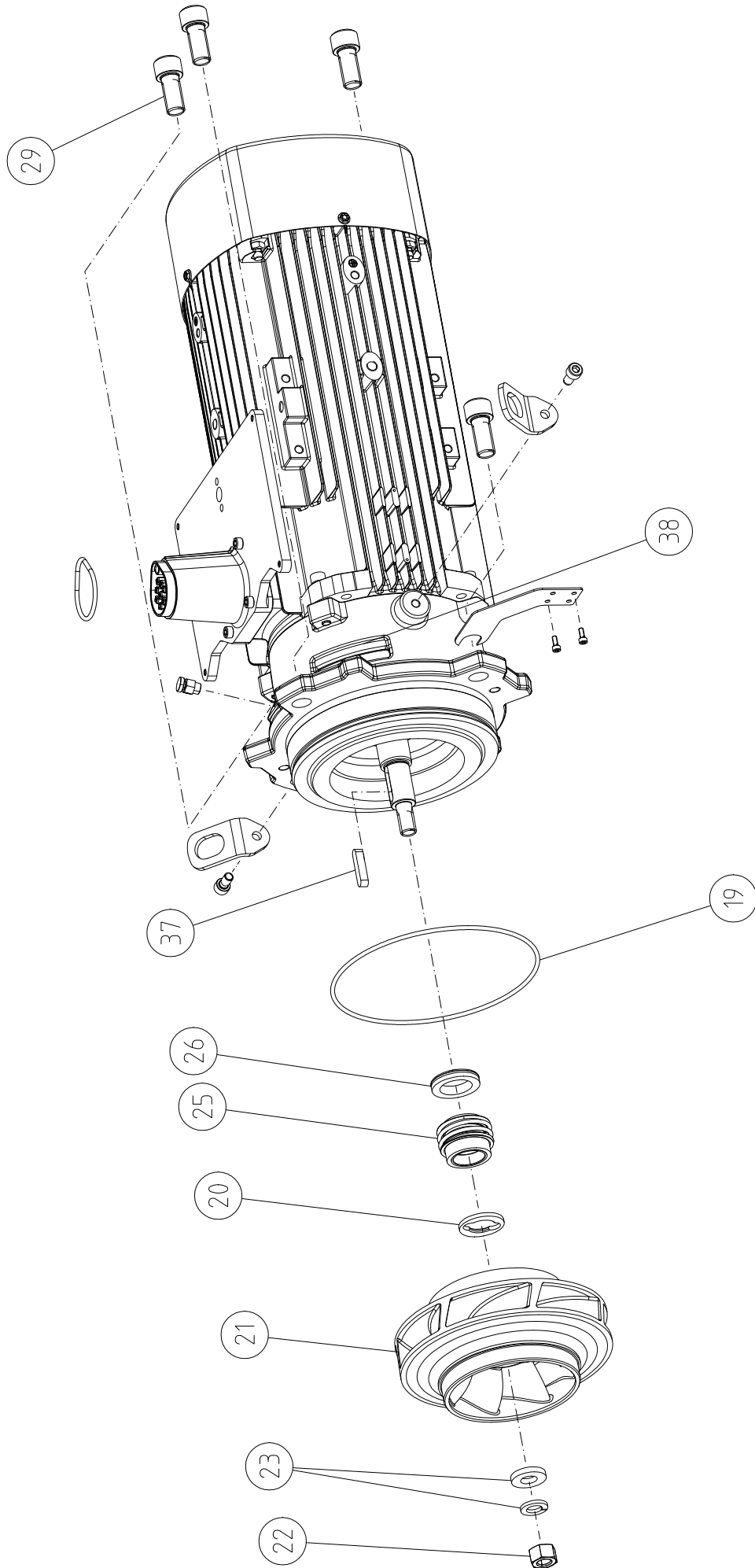

Fig. IV: Yonos GIGA2.0-I (11-22 kW)

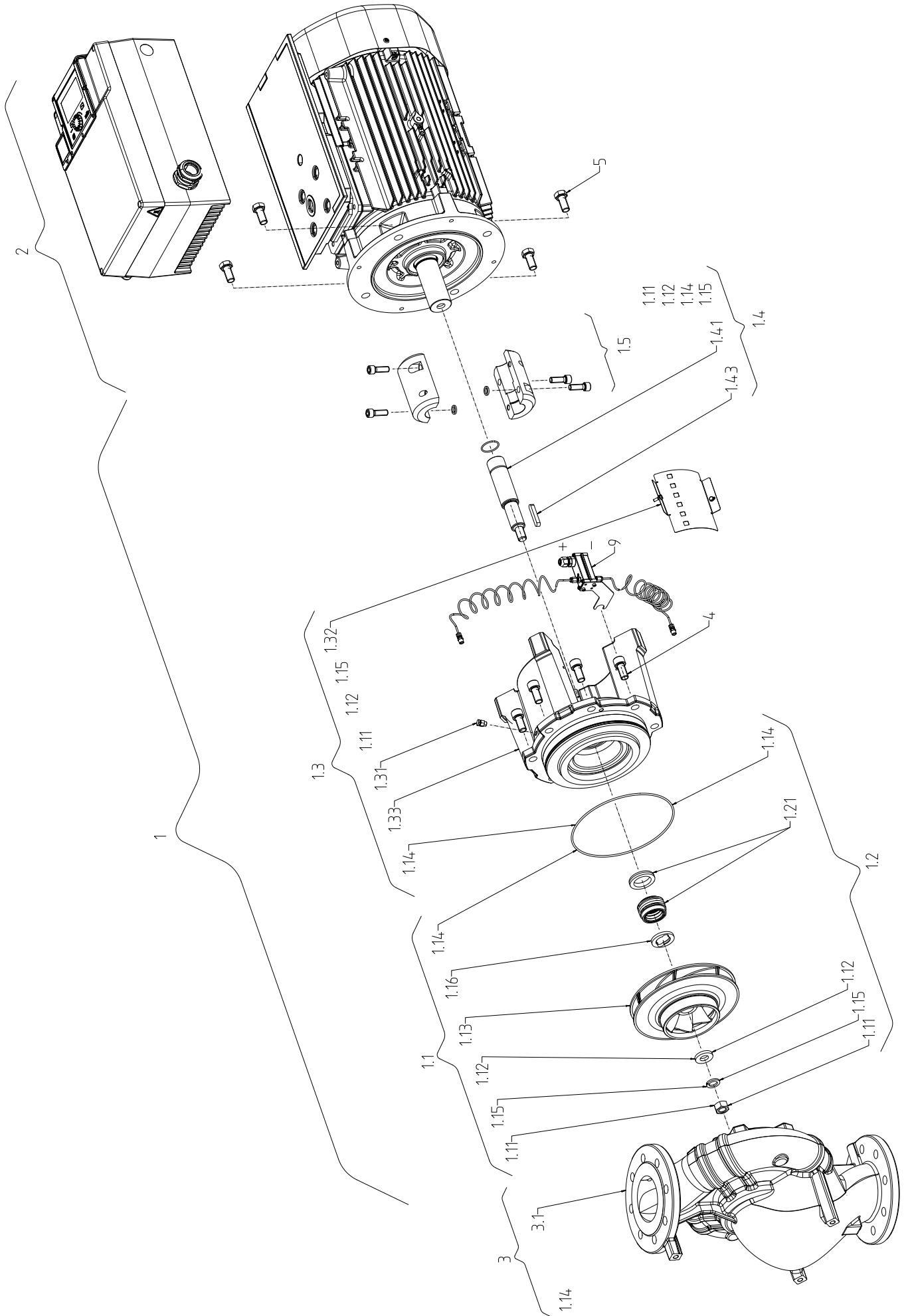

Fig. V: Yonos GIGA2.0-B (11-22 kW)

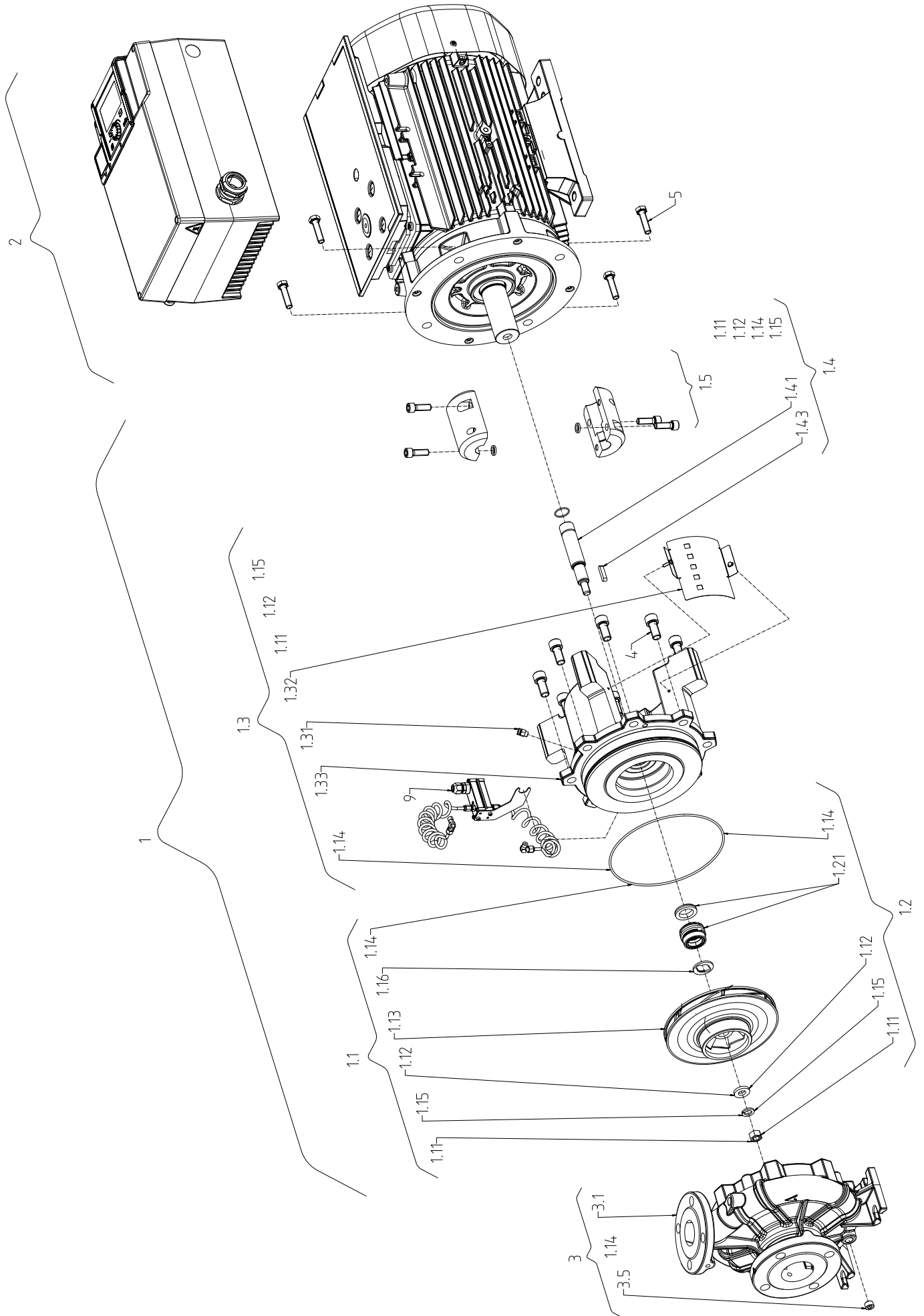

Fig. VI: Yonos GIGA2.0-D (11-22 kW)

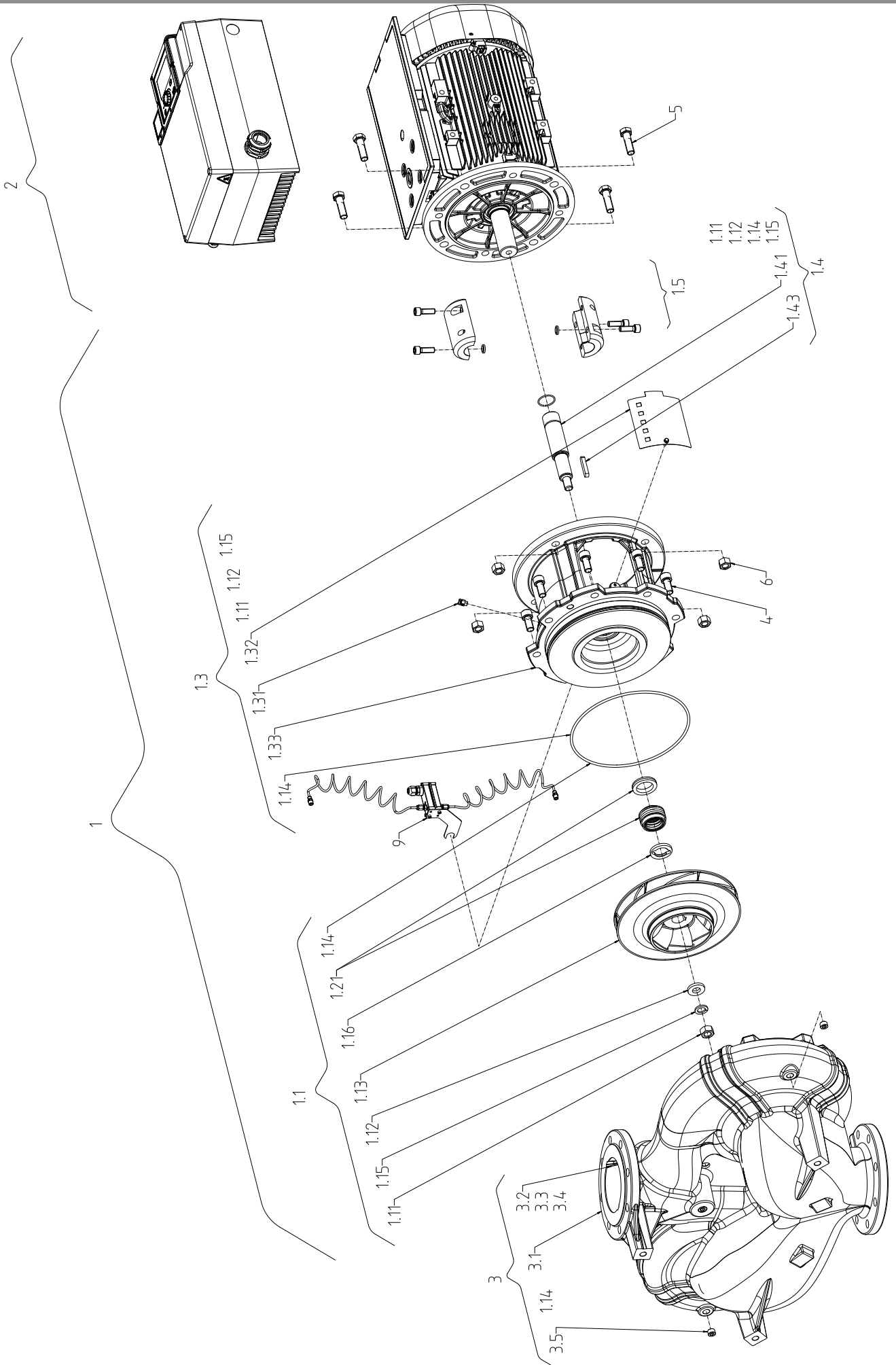

Fig. VII a: \leq DN 80

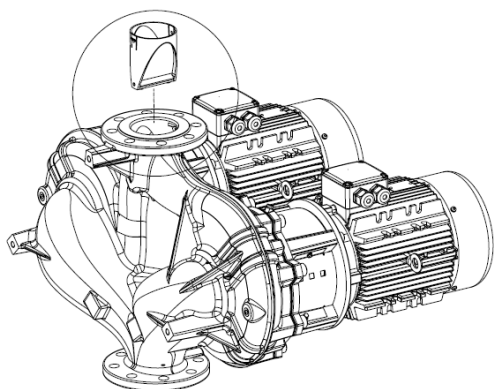

Fig. VIII b: DN 100 / DN 125

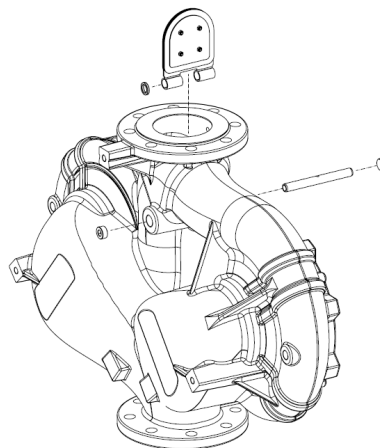

Fig. IX c: DN 150 / DN 200

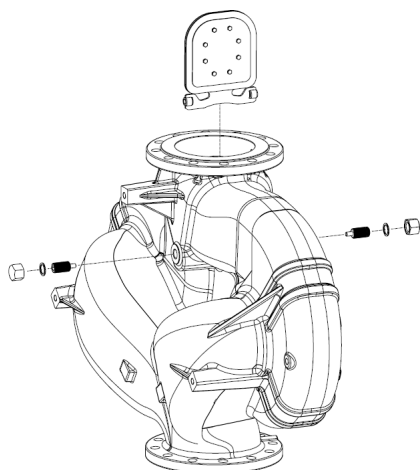



Table of contents

1 General	12	10.6 Configuration storage/data storage	65
1.1 About these instructions	12	11 Double pump operation	65
1.2 Copyright	12	11.1 Dual pump management	65
1.3 Subject to change.....	12	11.2 Twin-head pump behaviour	66
2 Safety	12	11.3 Settings menu – dual pump management.....	66
2.1 Identification of safety instructions	12	11.4 Display for twin-head pump operation.....	70
2.2 Personnel qualifications.....	13	12 Communication interfaces: Setting and function	72
2.3 Electrical work.....	13	12.1 Menu overview of “External interfaces”.....	73
2.4 Transport.....	14	12.2 SSM application and function	73
2.5 Installing/dismantling.....	14	12.3 SSM relay forced control.....	74
2.6 Maintenance work	14	12.4 SBM application and function	75
2.7 Operator responsibilities	15	12.5 SBM relay forced control.....	76
3 Intended use and misuse	15	12.6 Application and function of the digital control input DI1	76
3.1 Intended use.....	15	12.7 Application and function of the analogue inputs AI1 and AI2.....	78
3.2 Misuse.....	16	12.8 Application and function of the Wilo Net interface	85
4 Description of the pump	16	12.9 Application and function of CIF module.....	86
4.1 Type key.....	20	13 Display settings	86
4.2 Technical data	21	13.1 Display brightness	86
4.3 Scope of delivery.....	22	13.2 Language	86
4.4 Accessories	23	13.3 Unit	87
5 Transport and storage	23	13.4 Key lock.....	88
5.1 Shipping	23	14 Additional settings	88
5.2 Transport inspection	23	14.1 Pump kick	89
5.3 Storage	23	14.2 Ramp times for setpoint change	89
5.4 Transport for installation/dismantling purposes.....	24	14.3 Automatic PWM frequency reduction	89
6 Installation	25	14.4 Standstill heating.....	90
6.1 Personnel qualifications.....	25	15 Diagnostics and measured values	90
6.2 Operator responsibilities	25	15.1 Diagnostics help	92
6.3 Safety.....	25	15.2 Device information.....	92
6.4 Permitted installation positions and change of the arrangement of components before the installation	27	15.3 Service information	92
6.5 Preparing the installation	35	15.4 Error details.....	93
6.6 Twin-head pump installation/Y-pipe installation	39	15.5 Overview of the SSM relay status.....	93
6.7 Installation and position of additional sensors to be connected.....	40	15.6 Overview of the SBM relay status.....	93
7 Electrical connection	40	15.7 Overview of the analogue inputs AI1 and AI2	94
7.1 Mains connection.....	46	15.8 Overview of the twin-head pump connection.....	94
7.2 SSM and SBM connection	48	15.9 Overview of the pump cycling status	94
7.3 Connection of digital, analogue and bus inputs.....	48	15.10 Measured values	95
7.4 Differential pressure sensor connection	49	16 Reset	96
7.5 Wilo Net connection for twin-head pump function.....	49	16.1 Factory setting.....	96
7.6 Turn of the display	50	17 Faults, causes and remedies	97
8 Installation of CIF module	51	17.1 Mechanical faults without error messages	98
9 Commissioning	51	17.2 Error messages.....	98
9.1 Filling and venting	52	17.3 Warning messages.....	100
9.2 Procedure after switching on the power supply during initial commissioning	53	18 Maintenance	103
9.3 Description of operating elements	54	18.1 Air supply	105
9.4 Pump operation.....	54	18.2 Maintenance tasks.....	105
10 Control settings	61	19 Spare parts	115
10.1 Control functions.....	61	20 Disposal	115
10.2 Selecting a control mode.....	61	20.1 Oils and lubricants	116
10.3 Setting the setpoint source.....	63	20.2 Information on the collection of used electrical and electronic products.....	116
10.4 Emergency operation.....	64		
10.5 Switch off motor	64		

1 General

1.1 About these instructions

These instructions form part of the product. Compliance with the instructions is essential for correct handling and use:

- Read the instructions carefully before all activities.
- Keep the instructions in an accessible place at all times.
- Observe all product specifications.
- Observe the markings on the product.

The language of the original operating instructions is German. All other languages of these instructions are translations of the original operating instructions.

1.2 Copyright

WILO SE © 2026

The reproduction, distribution and utilisation of this document in addition to communication of its contents to others without express consent is prohibited. Offenders will be held liable for payment of damages. All rights reserved.

1.3 Subject to change

Wilo shall reserve the right to change the listed data without notice and shall not be liable for technical inaccuracies and/or omissions. The illustrations used may differ from the original and are intended as an exemplary representation of the product.

2 Safety

This chapter contains basic instructions for the individual life cycles of the product. Failure to observe this information carries the following risks:

- Danger to persons from electrical, mechanical and bacteriological effects as well as electromagnetic fields
- Environmental damage from discharge of hazardous substances
- Damage to property
- Failure of important product functions
- Failure of required maintenance and repair procedures

Failure to observe the instructions will result in the loss of any claims for damages.

The directions and safety instructions in the other sections must also be observed!

2.1 Identification of safety instructions

These installation and operating instructions set out safety instructions for preventing personal injury and damage to property. These safety instructions are shown differently:

- Safety instructions relating to personal injury start with a signal word, are **preceded by a corresponding symbol** and are shaded in grey.



DANGER

Type and source of the danger!

Consequences of the danger and instructions for avoidance.

- Safety instructions relating to property damage start with a signal word and are displayed **without** a symbol.

CAUTION

Type and source of the danger!

Consequences or information.

Signal words

- **DANGER!**
Failure to follow the instructions will result in serious injuries or death!
- **WARNING!**
Failure to follow the instructions can lead to (serious) injury!
- **CAUTION!**
Failure to follow the instructions can lead to potentially irreparable property damage.
- **NOTICE!**
Useful information on handling the product

Symbols

These instructions use the following symbols:



General danger symbol



Danger of electric voltage



Warning of hot surfaces



Warning of magnetic fields



Warning of high pressure



Notes

Follow all information that appears on the product and ensure that it remains permanently legible:

- Warning and hazard notices
- Rating plate
- Direction of rotation arrow/symbol for direction of flow
- Labelling of connections

Identifying Cross References

The name of the section or table is in inverted commas [“ ”]. The page number follows in square brackets [].

2.2 Personnel qualifications

Staff must:

- be instructed about locally applicable regulations governing accident prevention,
- have read and understood the installation and operating instructions.

Personnel must have the following qualifications:

- Electrical work: a qualified electrician must carry out the electrical work.
- Installation/dismantling: The technician must be trained in the use of the necessary tools and fixation materials.
- The product must be operated by persons who have been instructed on how the complete system functions.
- Maintenance work: The technician must be familiar with the use of operating fluids and their disposal.

Definition of “qualified electrician”

A qualified electrician is a person with appropriate technical education, knowledge and experience who can identify **and** prevent electrical hazards.

The operator must confirm and ensure the field of authority, the competence and the monitoring of the personnel. If the personnel do not possess the necessary knowledge, they must be trained and instructed. If required, this can be carried out by the product manufacturer at the operator’s request.

2.3 Electrical work

- Have electrical work carried out by a qualified electrician.
- When connecting to the local power supply system, comply with the nationally applicable guidelines, standards and regulations as well as specifications issued by the local energy supply companies.
- Before commencing work, disconnect the product from the mains and secure it against being switched on again.
- Give personnel training on how to establish the electrical connection and the methods for switching off the product.
- Protect the electrical connection with a residual-current device (RCD).
- Observe the technical information in these installation and operating instructions as well as on the rating plate.
- Earth the product.
- Comply with the manufacturer’s specifications when connecting the product to electrical switching systems.
- Have a defective connection cable replaced immediately by a qualified electrician.
- Never remove operating elements.
- If radio waves (Bluetooth) lead to hazards (e.g. in hospitals), they must be switched off or removed if they are not desired or prohibited at the installation location.



DANGER

When dismantled, the permanent magnet rotor inside the pump can pose mortal danger for people with medical implants (e.g. pacemakers).

- Follow the general behavioural guidelines that apply to handling electrical devices!
- Do not open the motor!
- Dismantling and installation of the rotor may only be carried out by Wilo customer service! If you have been fitted with a pacemaker, you must **not** carry out this kind of work!



NOTICE

The magnets inside the motor do not pose a danger **provided the motor is completely assembled**. Persons with pacemakers can approach the pump without restrictions.

2.4 Transport

- Wear protective equipment:
 - Safety gloves for protection against cuts
 - Safety shoes
 - Sealed safety glasses
 - Safety helmet (when using lifting equipment)
- Only use legally specified and approved lifting slings.
- Select the lifting sling based on the prevailing conditions (weather, slinging point, load etc.).
- Always attach the lifting sling to the designated slinging points (lifting eyes).
- Position the lifting accessory in a way that ensures stability during use.
- When using lifting equipment, a second person must be present to coordinate the procedure if required (e.g. if the operator's field of vision is blocked).
- Persons must not stand underneath suspended loads. Do **not** move suspended loads over workplaces where people are present.

2.5 Installing/dismantling

- Wear protective equipment:
 - Safety shoes
 - Safety gloves for protection against cuts
 - Safety helmet (when using lifting equipment)
- Locally applicable laws and regulations on work safety and accident prevention must be complied with.
- The procedure described in the installation and operating instructions for shutting down the product/unit must be strictly observed.
- Disconnect the device from the mains and secure it against being switched on again without authorisation.
- All rotating parts must be at a standstill.
- Close the gate valve in the inlet and in the discharge line.
- Provide adequate aeration in enclosed spaces.
- Make sure that there is no risk of explosion when carrying out any type of welding work or work with electrical devices.

2.6 Maintenance work

- Wear protective equipment:
 - Sealed safety glasses
 - Safety shoes
 - Safety gloves for protection against cuts
- Locally applicable laws and regulations on work safety and accident prevention must be complied with.
- The procedure described in the installation and operating instructions for shutting down the product/unit must be strictly observed.
- Only perform the maintenance work described in these installation and operating instructions.
- Only original parts from the manufacturer may be used for maintenance and repairs. The use of any non-original parts releases the manufacturer from any liability.
- Disconnect the device from the mains and secure it against being switched on again without authorisation.
- All rotating parts must be at a standstill.
- Close the gate valve in the inlet and in the discharge line.
- Collect any leakage of fluid and operating fluid immediately and dispose of it according to the locally applicable guidelines.
- Store tools at the designated locations.

2.7 Operator responsibilities

- After completing work, reattach all safety and monitoring devices and check that they function properly.
- Provide installation and operating instructions in a language the personnel can understand.
- Make sure that personnel are suitably trained for the specified work.
- Verify the area of responsibility and individual responsibilities of personnel.
- Provide the necessary protective equipment and make sure that personnel wear it.
- Ensure that safety and information signs mounted on the device are always legible.
- Train personnel with regard to the operating principles of the system.
- Eliminate risks from electrical current.
- Equip hazardous components (extremely cold, extremely hot, rotating, etc.) with a guard to be provided by the customer.
- Remove leakages of hazardous fluids (e.g. explosive, toxic or hot) in such a way that no danger is posed to persons or the environment. Comply with national statutory provisions.
- Keep highly flammable materials at a safe distance from the product.
- Ensure compliance with the regulations for accident prevention.
- Ensure compliance with local directives or general directives [e.g. IEC, VDE, etc.] and instructions from local energy supply companies.

Follow all information that appears on the product and ensure that it remains permanently legible:

- Warning and hazard notices
- Rating plate
- Direction of rotation arrow/symbol for direction of flow
- Labelling of connections

The product must not be operated by persons (including children) with limited physical, sensory or mental capabilities unless they have been trained in the use of the product by a person responsible for their safety.

Children must be supervised to ensure that they do not play with the product.

3 Intended use and misuse

3.1 Intended use

The glanded pumps in the Yonos GIGA2.0 series are intended for use as circulators in building services.

They may be used for:

- Hot-water heating systems
- Cooling and chilled water circulation systems
- Industrial circulation systems
- Heat transfer loops

Installation within a building:

Glanded pumps are to be installed in dry, well-ventilated, frost-proof rooms.

Installation outside a building

- Observe permissible environmental conditions and IP rating.
- Observe permissible ambient temperatures (see “Technical data” table).
- The permissible installation positions for installation outside a building (see “Permitted installation positions for installation outside a building” section) must be adhered to.
- Adhere to the sound insulation requirements for the installation site.
- Protect the pump against the effects of weather, such as direct sunlight, rain and snow, by covering it from all sides.
The cover must be installed on-site to suit the local conditions.
- Ensure free air access to the heat sink of the electronic module.
- Maintain a minimum axial distance of 400 mm between walls and the fan cover of the motor.
- Protect the pump so that the condensate drain openings remain free of dirt.
- Take suitable measures to prevent the formation of condensation water.



NOTICE

For installation outside a building, we recommend ordering the pump with fully painted pump housing, a lantern and a motor.



NOTICE

The display may fail if the ambient temperatures are very low. To maintain the pump's IP55 rating, do not remove the display.

Intended use includes compliance with these instructions as well as the information and markings on the pump.

Any use beyond the intended use is considered misuse and will result in the loss of all liability claims.

3.2 Misuse

The operational reliability of the supplied product is only guaranteed for intended use in accordance with chapter "Intended use" of the installation and operating instructions. The limit values must not fall below or exceed those values specified in the catalogue/data sheet.



WARNING

Misuse of the pump can lead to dangerous situations and damage!

Non-permitted substances in the fluid can destroy the pump. Abrasive solids (e.g. sand) increase pump wear.

Pumps without an Ex rating are not suitable for use in potentially explosive atmospheres.

- Never use fluids other than those approved by the manufacturer.
- Highly flammable materials/fluids should always be kept at a safe distance from the device.
- Never allow unauthorised persons to carry out work.
- Never operate the pump beyond the specified limits of use.
- Never carry out unauthorised conversions.
- Use authorised accessories and original spare parts only.

4 Description of the pump

The Yonos GIGA2.0 pump with high energy efficiency is a glanded pump with integrated power adjustment. In the performance range from 0.37 kW to 7.5 kW, electronic commutated motor (ECM) technology is used. In the performance range 11 kW to 22 kW, asynchronous (AC) motor technology is used. The pump is designed as a single-stage low-pressure centrifugal pump with flange connection and mechanical seal.

The pump can be installed both directly as a pipe installation in sufficiently secured pipes or be placed on a foundation base. Mounting brackets (accessories) are available for installation on a foundation base (see "Accessories" [► 23] section).

The pump housing is an in-line design; i.e. the flanges on the suction and discharge side are on one axle. All pump housings are provided with pump support feet. Installation on a foundation base is recommended.



NOTICE

Blind flanges are available for all pump types/housing sizes from the Yonos GIGA2.0-D series (for accessories, see the "Accessories" [► 23] section). This way a drive can remain in operation when replacing the motor impeller unit (motor with impeller and electronic module).

Fig. I to III show an exploded view drawing of the pump (0.37 kW to 7.5 kW) with the main components. The pump structure is explained in detail below.

Arrangement of the main components according to Fig. I to III of the table "Arrangement of the main components":

No.	Component
1	Electronic module lower part
2	Electronic module upper part
3	Fastening screws of the electronic module upper part, 4x
4	Fastening screws of the electronic module lower part, 4x
5	Clamping ring screw connection of the pressure sensing line (housing side), 2x

No.	Component
6	Union nuts of the clamping ring screw connection (housing side), 2x
7	Pressure sensing line, 2x
8	Differential pressure sensor (DDG)
9	Union nuts of the clamping ring screw connection (DDG side), 2x
10	Motor fastening screw, main fastening, 4x
10a	2x auxiliary fastening screws
11	Motor adapter for electronic module
12	Motor housing
13	DDG holder
14a	Fixation thread for transport lugs on motor flange, 2x
14b	Fixation thread for transport lugs on motor housing, 2x
15	Motor flange
16	Motor shaft
17	Thrower
18	Lantern
19	O-ring
20	Spacer on mechanical seal
21	Impeller
22	Impeller nut
23	Impeller nut washer
24	Pump housing
25	Rotating unit on mechanical seal
26	Stationary ring on mechanical seal
27	Protective plate (depending on pump type)
28	Air vent valve
29	Fastening screws from the motor impeller unit, 4x
30	Transport lug, 2x
31	O-ring of drive
32	Twin-head pump flap
33	Shim for the twin-head pump flap (depending on pump type)
34	Axle for twin-head pump flap (depending on pump type)
35	Axle bore screw plug, 2x (depending on pump type)
36a	Retaining ring
36b	Retaining ring
37	Key
38	Lantern window

Table 1: Arrangement of the main components (0.37 kW to 7.5 kW)

Fig. IV to VI show an exploded view drawing of the pump (11 kW to 22 kW) with the main components. The pump structure is explained in detail below.

Arrangement of the main components according to Fig. IV to VI of the table "Arrangement of the main components":

No.	Component
1	Exchange kit (complete)
1.1	Impeller kit
1.11	Nut
1.12	Conical spring washer
1.13	Impeller
1.14	O-ring

No.	Component
1.15	Shim
1.16	Shim
1.2	Mechanical seal kit
1.21	Mechanical seal
1.3	Lantern kit
1.31	Air vent valve
1.32	Coupling guard
1.33	Lantern
1.4	Coupling/shaft kit
1.41	Complete coupling/shaft
1.42	Circlip
1.43	Key
1.44	Coupling screws
1.5	Complete coupling
2	Motor with adapter plate for electronic module
3	Pump housing kit
3.1	Pump housing
3.2	Switchover valve ≤ DN 80 (only Yonos GIGA2.0-D)
3.3	Switchover valve DN 100/125 (only Yonos GIGA2.0-D)
3.4	Switchover valve DN 150/200 (only Yonos GIGA2.0-D)
3.5	Screw plug for drain hole
4	Fastening screws for lantern/pump housing
5	Fastening screws for motor/lantern
6	Nut for motor/lantern fixation
9	Differential pressure sensor (DDG)

Table 2: Arrangement of the main components (11 kW to 22 kW)

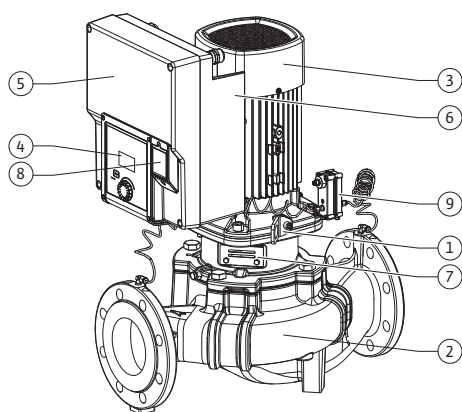

Fig. 1: Pump overview

Item	Designation	Explanation
1	Transport lugs	Used for transporting and lifting the components. See "Installation" [► 25] section.
2	Pump housing	Install according to "Installation" [► 25] section.
3	Motor	Drive unit. Forms the drive together with the electronic module.
4	Graphic display	Provides information about settings and pump status. User interface for setting the pump.
5	Electronic module	Electronic unit with graphic display.
6	Electrical fan	Cools down the electronic module (depending on type).
7	Protective plate in front of lantern window	Protects against rotating motor shaft (depending on pump type).
8	Wilo-Connectivity Interface	Optional interface
9	Differential pressure sensor	2 to 10 V with capillary tube connections on flanges of suction and discharge side

Table 3: Description of the pump

- Item 3: The motor with mounted electronic module can be rotated relative to the lantern. Observe the instructions in the "Permitted installation positions and change of the arrangement of components before installation" [► 27] section.
- Item 4: The display can be rotated in 90° steps as required. (See "Turning the display [► 50]" section.)
- Item 6: An unobstructed and free air flow must be ensured around the electric fan. (see "Installation" [► 25] section).

- Item 7: The protective plate must be dismantled for the leakage check (depending on pump type). Observe the safety instructions in “Commissioning” [► 51] section!

Rating plate (Fig. 2) for motor power 0.37 kW to 7.5 kW

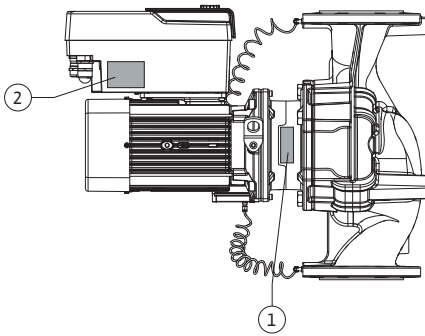

Fig. 2: Rating plates

1	Pump rating plate	2	Drive rating plate
---	-------------------	---	--------------------

- There is a serial number on the pump rating plate. It must be specified e.g. for ordering spare parts.
- The drive rating plate is located on the side of the electronic module. The electrical connection must be designed according to the specifications on the drive rating plate.

Rating plate (Fig. 3) for motor power 11 kW to 22 kW

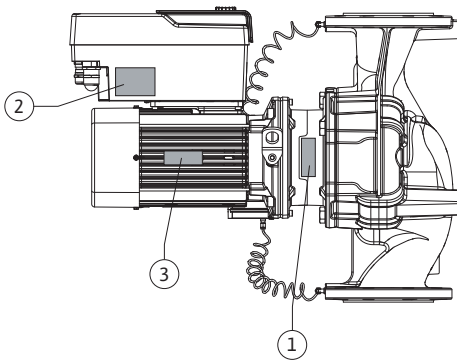

Fig. 3: Rating plate 11 to 22 kW

1	Pump rating plate
2	Drive rating plate
3	Motor rating plate

Table 4: Rating plate for 11 kW to 22 kW

- There is a serial number on the pump rating plate. It must be specified e.g. for ordering spare parts.
- The drive rating plate is located on the side of the electronic module. The electrical connection must be designed according to the specifications on the drive rating plate.
- The motor rating plate is located on the side of the motor housing.

Functional assemblies (Fig. 4)

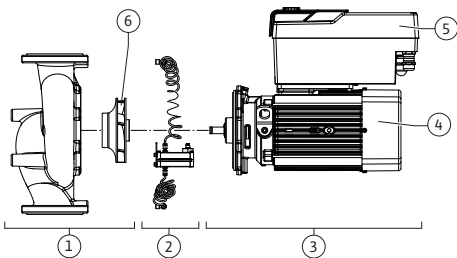

Fig. 4: Functional assemblies

Item	Designation	Description
1	Hydraulic unit	The hydraulic unit consists of the pump housing and impeller.
2	Differential pressure sensor	Differential pressure sensor with connection and fixation elements
3	Drive	The drive consists of a motor and an electronic module.
4	Motor	With integrated or separate pump lantern, depending on the pump type
5	Electronic module	Electronic unit
6	Impeller	

Table 5: Functional assemblies

The motor drives the hydraulic unit. The electronic module takes over the control of the motor.

The hydraulic unit is not a ready-to-install assembly due to the continuous motor shaft. It is disassembled for most maintenance and repair work. For information on maintenance and repair work, see “Maintenance” [► 103] section.

Motor impeller unit

The impeller and lantern (depending on the pump type) together with the motor form the motor impeller unit (Fig. 5).

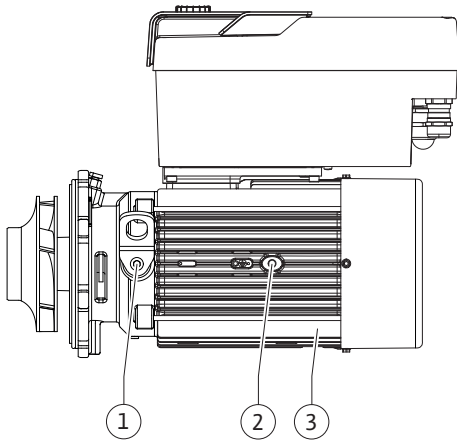

Fig. 5: Motor impeller unit

4.1 Type key

The motor impeller unit can be separated from the pump housing for the following purposes:

- The motor with the electronic module must be turned to a different relative position to the pump housing.
- Access to the impeller and mechanical seal is required.
- The motor and hydraulic unit must be separated.

The pump housing can remain in the pipe.

Observe “Permitted installation positions and change of the arrangement of components before installation” [► 27] section and the “Maintenance” [► 103] section.

Motor power 0.37 kW to 7.5 kW

Example: Yonos GIGA2.0-I 65/1-20/M-4.0-xx

Yonos GIGA	Pump designation
2.0	Second generation
-I	Inline single pump
-D	Twin-head in-line pump
-B	Monobloc pump
65	Flange connection DN 65 (the discharge flange size for monobloc pumps)
1-20	Continuously adjustable setpoint height 1: Minimum delivery head in m 20: Maximum delivery head in m at $Q = 0 \text{ m}^3/\text{h}$
M-	Variant with power supply 1~230 V
4.0	Rated power in kW
-xx	Variant, e.g. R1

Table 6: Type key

Motor power 11 kW to 22 kW

Example: Yonos GIGA2.0-I 65/150-11/2-xx

Yonos GIGA	Pump designation
2.0	Second generation
-I	Inline single pump
-D	Twin-head in-line pump
-B	Monobloc pump
65	Flange connection DN 65 (the discharge flange size for monobloc pumps)
150	Nominal impeller diameter in mm ¹⁾
11	Rated power in kW
2	Number of poles
-xx	Variant, e.g. R1

¹⁾ Does not correspond to the actual impeller diameter. Use the spare parts catalogue for spare parts.

Table 7: Type key

For an overview of all product variants, see Wilo-Select/Catalogue.

4.2 Technical data

Property	Value	Remark
Electrical connection:		
Voltage range	3~380 V to 3~480 V ($\pm 10\%$), 50/60 Hz	Supported mains types: TN, TT, IT ¹⁾
Voltage range	1~220 V to 1~240 V ($\pm 10\%$), 50/60 Hz	Supported mains types: TN, TT, IT ¹⁾
Performance range	3~ 0.55 kW to 22 kW	Depending on pump type
Performance range	1~ 0.37 kW ... 1.5 kW	Depending on pump type
Speed range	450 rpm to 3600 rpm	Depending on pump type
Ambient conditions²⁾:		
IP rating	IP55	EN 60529
Ambient temperature during operation min./max. (3~)	-30 °C to +50 °C	Lower or higher ambient temperatures on request
Ambient temperature during operation min./max. (1~)	0 °C to +50 °C	Lower or higher ambient temperatures on request
Temperature during storage min./max.	-30 °C ... +70 °C	> +60 °C limited to a duration of 8 weeks.
Temperature during transport min./max.	-30 °C ... +70 °C	> +60 °C limited to a duration of 8 weeks.
Relative humidity	< 95 %, non-condensing	
Installation height max.	2000 m above sea level	The pumps may be loaded with 100% drive power up to an installation altitude of 2000 m. An installation altitude of up to 3500 m is possible on request for motor powers from 11 to 22 kW only.
Insulation class	F	
Pollution degree	2	DIN EN 61800-5-1
Motor protection	Integrated	
Overvoltage protection	Integrated	
Overvoltage category	OVC III + SPD/MOV ³⁾	Overvoltage Category III + Surge Protective Device/Metal Oxide Varistor
Protection function control terminals	SELV, galvanically isolated	
Electromagnetic compatibility ⁷⁾		
Interference emission in acc. with:	EN 61800-3:2018	Residential environment (C1) ⁶⁾
Interference immunity in acc. with:	EN 61800-3:2018	Industrial environment (C2)
Sound-pressure level ⁴⁾	$L_{pA, 1m} < 81$ dB (A) ref. 20 μ Pa	Depending on pump type
Nominal diameters DN	Yonos GIGA2.0-I/-D/-B: 32/40/50/65/80/100/125/150/200	
Pipe connections	Flanges PN 16	EN 1092-2
Max. permissible operating pressure	16 bar (up to +120 °C) 13 bar (up to +140 °C)	
Permissible min./max. fluid temperature	-20 °C to +120 °C -20 °C to +140 °C	Depending on fluid and pump type

Property	Value	Remark
Permissible fluids ⁵⁾	Heating water in accordance with VDI 2035 Part 1 and Part 2	Standard version Standard version
	Cooling/chilled water	
	Water-glycol mixture up to 40 % Vol.	Standard version
	Water-glycol mixture up to 50 % Vol.	Only for special version Only for special version
	Heat transfer oil	Only for special version
	Other fluids	

¹⁾ TN and TT power supplies with earthed live wires are not permitted.

²⁾ For more detailed, product-specific information such as power consumption, dimensions and weights, refer to the technical documentation in the catalogue or Wilo-Select online.

³⁾ Over Voltage Category III + Surge Protective Device/Metall Oxid Varistor

⁴⁾ Average value of the sound-pressure levels on a spatially rectangular measuring surface at a distance of 1 m from the pump surface in accordance with DIN EN ISO 3744.

⁵⁾ For more information about permissible fluids, see the "Fluids" section.

⁶⁾ In the case of the DN 100 and DN 125 pump types with motor powers of 2.2 and 3 kW, EMC irregularities can occur under unfavourable circumstances when used in residential environments (C1) with low electrical power in the conducted range. In this case, please contact WILO SE so that together we can find a quick and suitable shutdown measure.

⁷⁾ Yonos GIGA2.0-I/-D is a professional device within the meaning of EN 61000-3-2.

Table 8: Technical data

Additional information CH	Permissible fluids
Heating pumps	Heating water (in accordance with VDI 2035/VdTÜV Tch 1466/CH: in accordance with SWKI BT 102-01) ... No oxygen binding agents, no chemical sealants (ensure closed system from corrosion perspective according to VDI 2035 (CH: SWKI BT 102-01); rework leaky points).

Fluids

Water-glycol mixtures or fluids with a different viscosity than pure water increase the power consumption of the pump. Only use mixtures with corrosion protection. **Observe the relevant manufacturer's specifications!**

- The fluid must be sediment-free.
- Wilo's approval must be obtained for the use of other fluids.
- Mixtures with a proportion of glycol of > 10 % influence the Δp -v characteristic curve and the flow calculation.
- The compatibility of the standard seal/standard mechanical seal with the fluid is generally given under normal system conditions.
Special circumstances may require special seals, for example:
 - solids, oils or EPDM-attacking substances in the fluid,
 - air content in the system, etc.

Observe the safety data sheet for the fluid to be pumped!



NOTICE

When using water-glycol mixtures, the use of an S1 variant with a corresponding mechanical seal is generally recommended.

4.3 Scope of delivery

- Pump
- Installation and operating instructions and declaration of conformity



NOTICE

The following are factory mounted:

- For motor power 0.37 to 7.5 kW:
M25 threaded cable gland for the mains connection and M20 threaded cable gland for the cable for the differential pressure sensor/dual-pump communication.
 - For motor power 11 to 22 kW:
M40 threaded cable gland for the mains connection and M20 threaded cable gland for the cable for the differential pressure sensor/dual-pump communication.
- ▶ All other required threaded cable glands M20 must be provided by the customer.

4.4 Accessories

Accessories must be ordered separately.

- 3 mounting brackets with fixation material for installation on a base
- Supports for installation on a base (Yonos GIGA2.0-B)
- Blind flanges for twin-head pump housing
- CIF module PLR for connecting to PLR/interface converter
- CIF module LON for connection to the LONWORKS mains network
- CIF module BACnet
- CIF module Modbus
- CIF module CANopen
- CIF module Ethernet Multi-protocol (Modbus TCP, BACnet/IP)
- Connection M12 RJ45 CIF Ethernet (for easy disconnection of data cable connection in the event of maintenance)
- Threaded cable gland set
- Differential pressure sensor DPS 2 ... 10 V
- Differential pressure sensor DPS 4 ... 20 mA

For a detailed list, consult the catalogue and spare parts documentation.



NOTICE

CIF modules may only be plugged in when the pump is de-energised (voltage-free).

5 Transport and storage

5.1 Shipping

The pump is secured to a pallet ex works, packaged in a box and protected against dirt and moisture.

5.2 Transport inspection

Check delivery immediately for damage and completeness. Defects must be noted on the freight documentation! Defects must be notified to the transport company or the manufacturer immediately on the day of receipt of shipment. Subsequently notified defects can no longer be claimed for.

Only remove the outer packaging at the place of utilisation to ensure that the pump is not damaged during transport.

5.3 Storage

CAUTION

Property damage due to improper transport and storage!

- Protect the product from moisture, frost and mechanical damage during transport and temporary storage.

Leave stickers on the pipe connections so that no dirt and other foreign matter can get into the pump housing.

To prevent scoring at the bearings and sticking, turn the pump shaft once a week using a socket wrench (see Fig. 6).

If a longer storage time is required, contact Wilo for preservation measures.

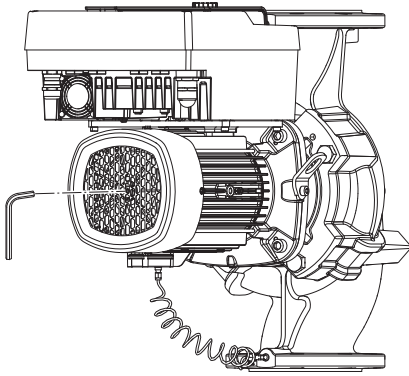

Fig. 6: Turning the shaft

5.4 Transport for installation/dismantling purposes

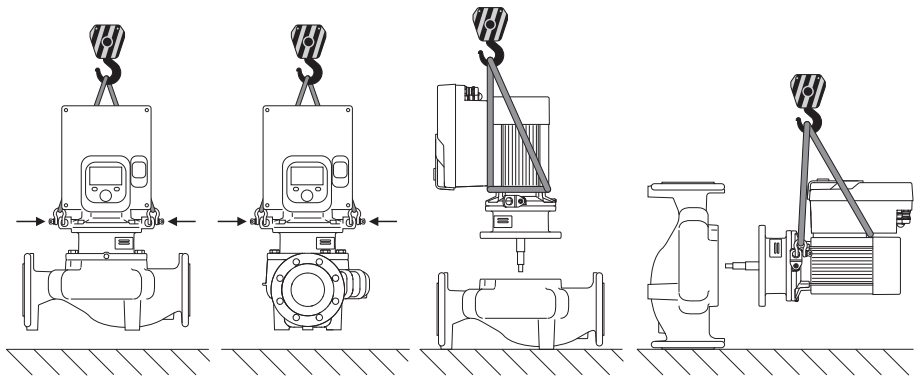

Fig. 7: Single pump lifting direction

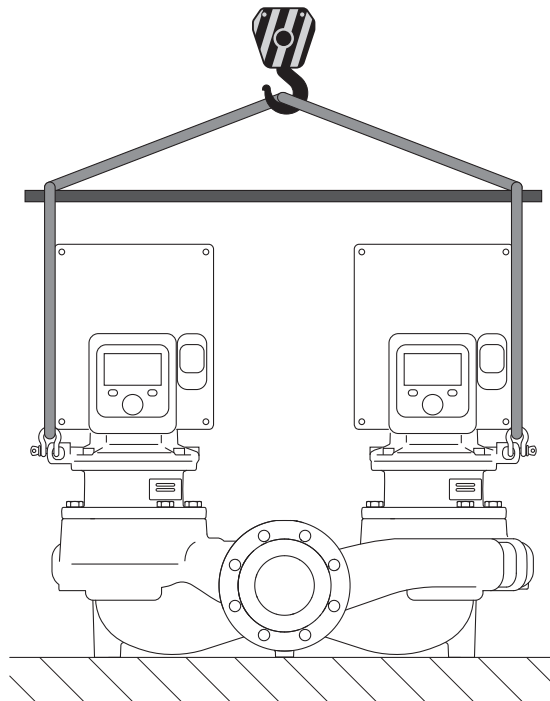

Fig. 8: Twin-head pump lifting direction

The pump must be transported using approved lifting accessory (block and tackle, crane, etc.). The lifting accessory must be attached to the transport lugs at the motor flange. Slide the lifting loops under the adapter plate, if necessary (Fig. 7/8). Secure the pump against tipping.



WARNING

Damaged transport lugs can break off and cause considerable personal injury.

- Check the transport lugs before use for damage and secure fixation.



NOTICE

To improve the weight distribution, the transport lugs can be swivelled/rotated according to the lifting direction.
To do so, loosen and then re-tighten the fastening screws!



DANGER

Danger of death from falling parts!

The pump itself and pump parts can have a very high net weight. Falling parts pose a risk of cuts, crush injuries, bruises or impacts, which can be fatal.

- Always use suitable lifting accessories and secure parts against falling.
- Never stand below a suspended load.
- During storage and transport, as well as before all installation and assembly work, ensure that the pump is in a safe position and standing securely.



WARNING

Personal injury due to unsecured installation of the pump!

The base with the threaded holes is used for fixation only. When standing freely, the pump might not be sufficiently stable.

- Never place the pump unsecured on the pump support feet.

CAUTION

Improper lifting of the pump by the electronic module can cause damage to the pump.

- Never lift the pump by the electronic module.

6 Installation

6.1 Personnel qualifications

- Installation/dismantling: The technician must be trained in the use of the necessary tools and fixation materials.

6.2 Operator responsibilities

- Observe national and regional regulations!
- Observe locally applicable accident prevention and safety regulations of professional and trade associations.
- Provide protective equipment and ensure that the protective equipment is worn by personnel.
- Observe all regulations for working with heavy loads.

6.3 Safety



DANGER

When dismantled, the permanent magnet rotor inside the pump can pose mortal danger for people with medical implants (e.g. pacemakers).

- Follow the general behavioural guidelines that apply to handling electrical devices!
- Do not open the motor!
- Dismantling and installation of the rotor may only be carried out by Wilo customer service! If you have been fitted with a pacemaker, you must **not** carry out this kind of work!



DANGER

Risk of fatal injury due to lack of protective devices!

Due to missing protective devices of the electronic module or in the range of the coupling/motor, electric shock or contact with rotating parts can lead to life-threatening injuries.

- Before commissioning, safety devices such as such as electronic module covers or coupling covers that were removed must be reinstalled!



DANGER

Potentially fatal injury due to electronic module not being installed!

A life-threatening voltage may be present at the motor contacts! Normal operation of the pump is only permitted with the electronic module installed.

- Never connect or operate the pump without the electronic module mounted!



DANGER

Danger of death from falling parts!

The pump itself and pump parts can have a very high net weight. Falling parts pose a risk of cuts, crush injuries, bruises or impacts, which can be fatal.

- Always use suitable lifting accessories and secure parts against falling.
- Never stand below a suspended load.
- During storage and transport, as well as before all installation and assembly work, ensure that the pump is in a safe position and standing securely.



WARNING

Personal injury due to strong magnetic forces!

Opening the motor leads to high, abruptly occurring magnetic forces. This can lead to serious cuts, crushing injuries and bruises.

- Do not open the motor!



WARNING

Hot surface!

The entire pump can become very hot. There is a risk of burns!

- Allow the pump to cool down before commencing any work!



WARNING

Risk of scalding!

At high fluid temperatures and system pressures, allow the pump to cool down first and then depressurise the system.

CAUTION

Damage to the pump due to overheating!

The pump must not be allowed to run dry for more than 1 minute. Dry running causes a build-up of energy in the pump, which can damage the shaft, impeller, and mechanical seal.

- Make sure that the volume flow does not fall below the minimum value Q_{\min} .
-

Approximate calculation of Q_{min} :

$$Q_{min} = 10 \% \times Q_{max\ pump} \times \text{actual speed} / \text{max. speed}$$

6.4 Permitted installation positions and change of the arrangement of components before the installation

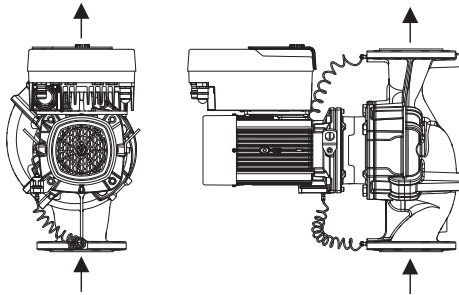

Fig. 9: Arrangement of the components upon delivery

The factory pre-installed component arrangement relative to the pump housing (see Fig. 9) can be changed on site if required. This may be necessary, for example, in the following cases:

- Ensuring pump venting
- Enabling better operation
- Avoid impermissible installation positions (motor and/or electronic module point downwards).

In most cases, it is enough to rotate the motor impeller unit relative to the pump housing. The possible arrangement of components is the result of the permitted installation positions.

6.4.1 Permitted installation positions with horizontal motor shaft

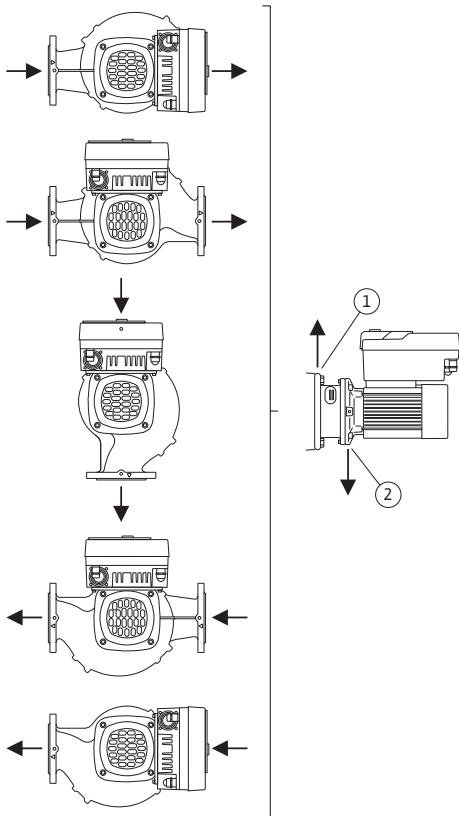

Fig. 10: Permitted installation positions with horizontal motor shaft

The permissible installation positions for a horizontal motor shaft and electronic module pointing upward (0°) are shown in Fig. 10.

Any installation position is allowed except for “electronic module facing down” (-180°).

Venting of the pump is best ensured when the air vent valve is pointing upwards (Fig. 10, Item 1).

In this position (0°), condensate can be directed away via existing drilled holes, pump lantern and motor (Fig. 10, Item 2).



NOTICE

The installation position with a horizontal motor shaft is only permissible up to a motor power of 15 kW.
No motor support is required.
For a motor power of >15 kW, only install with a vertical motor shaft.

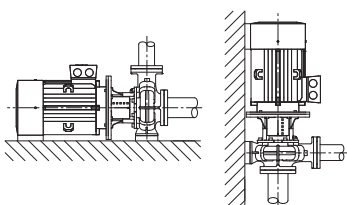

Fig. 11: Yonos GIGA2.0-B



NOTICE

Install monobloc pumps of the Yonos GIGA2.0-B series on a sufficient base or mounting brackets (Fig. 11).
Motors with a motor power of 18.5 kW and higher require a support. See installation examples.

For installations with a vertical motor position, the pump housing feet and motor housing feet must be screwed on. This must be done stress-free.

Unevenness between motor and pump housing feet must be levelled out for stress-free installation.

Yonos GIGA2.0-B installation examples:

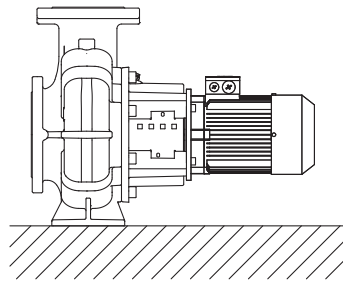

No support required

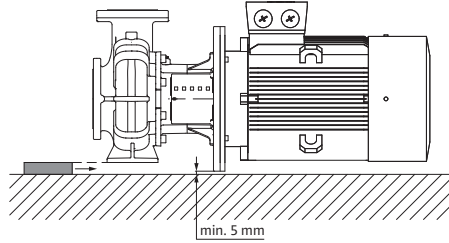

Pump housing supported

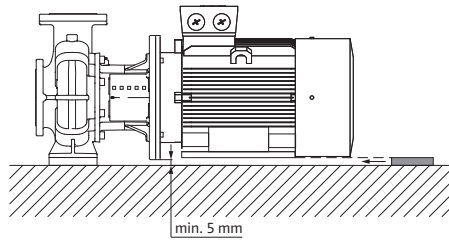

Motor supported

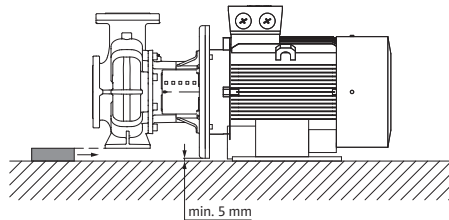

Pump housing supported, motor attached to the base

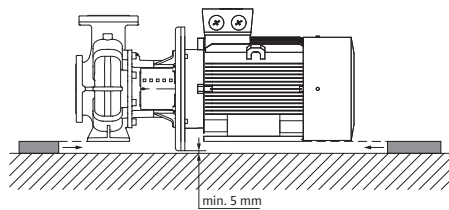

Pump housing and motor supported

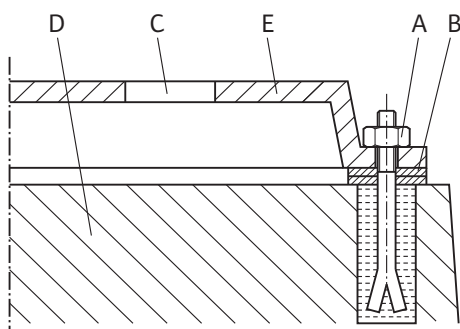

Example of a foundation screwed connection

- Align the complete unit when installing it on the foundation with the help of the spirit level (at the shaft/discharge port).
- Always place shims (B) on the left and right adjacent to fasteners (e.g. stone screws (A)) between the baseplate (E) and base (D).
- Evenly and firmly tighten the fixation material.
- For distances > 0.75 m, support the baseplate at the centre between the fixation elements.

Fig. 12: Example of a foundation screwed connection

6.4.2 Permitted installation positions with vertical motor shaft

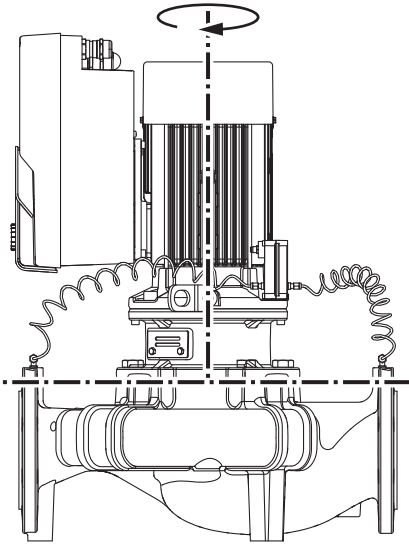

Fig. 13: Permitted installation positions with vertical motor shaft

The permitted installation positions with vertical motor shaft are shown in Fig. 10.

All installation positions except for “motor facing down” are allowed.

The motor impeller unit can be arranged in various positions relative to the pump housing.

Depending on the pump type, the following positions are possible:

- Eight different positions (8x45°)
- Four different positions (4x90°)

With twin-head pumps, it is not possible to turn both insertion sets in the direction of each other to the shaft axes due to the dimensions of the electronic modules.

6.4.3 Permitted installation positions for installation outside a building

For installation outside a building, only the following installation positions are permitted:

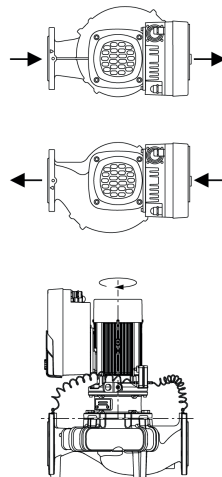

- Horizontal motor shaft with vertical electronic module in +/- 90° alignment
- Vertical motor shaft and electronic module

The following installation positions are not permitted:

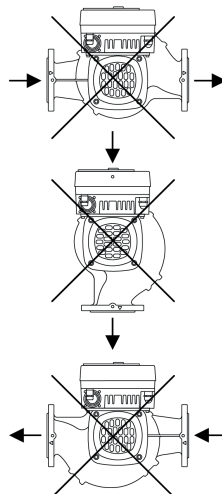

6.4.4 Turning the motor impeller unit (for motor power 0.37 kW to 7.5 kW)

- Installation positions with horizontal motor shaft and electronic module facing up (0°) and down (-180).

The motor impeller unit consists of an impeller, lantern and motor with electronic module.

Turn of motor impeller unit relative to pump housing



NOTICE

To make the installation work easier, it can be helpful to install the pump in the piping. Do not connect the pump electrically or fill the pump or system.

1. Leave two transport lugs (Fig. I, Item 30) on the motor flange.
2. Secure the motor impeller unit (Fig. 5) at the transport lugs with suitable lifting accessories. To prevent the unit from tipping, place a belt loop around the motor and adapter of the electronic module as shown in Fig. 7. When attaching, avoid damaging the electronic module.
3. Loosen and remove the screws (Fig. I to III, Item 29).



NOTICE

To unscrew the screws (Fig. I to III, Item 29), use an open-end spanner, angle spanner or socket wrench with ball head, depending on the type.

We recommend that you use two mounting bolts instead of two screws (Fig. II/III, Item 29). The mounting bolts are screwed diagonally to each other through the drilled hole in the lantern into the pump housing.

The installation bolts make it easier to avoid damaging the impeller when dismantling the motor impeller unit and then reinstalling it.

4. Loosen the screw (Fig. I/III, Item 29, Fig. II, Item 10) to remove the holder for the differential pressure sensor (Fig. I, Item 13) from the motor flange. Suspend the differential pressure sensor (Fig. I, Item 8) with the holder (Fig. I, Item 13) from the pressure sensing lines (Fig. I, Item 7). Disconnect the connection cable of the differential pressure sensor in the electronic module, if necessary.

CAUTION

Material damage due to bent or kinked pressure sensing lines.

Improper handling can damage the pressure sensing line.

When turning the motor impeller unit, do not bend or kink pressure sensing lines.

5. Detach the motor impeller unit (see Fig. 5) from the pump housing. Depending on the pump type (see Fig. I to III), there are different ways to do this. For the Fig. I pump type, loosen the screws (Item 29). Push the motor impeller unit off the pump housing. For Fig. II and Fig. III pump types, use the two threaded holes (Fig. 14, Item 1). Use suitable screws provided on-site (e.g. M10 x 25 mm) for this.



NOTICE

For the following steps, observe the screw tightening torque specified for the respective thread type! See table "Screws and tightening torques" [► 34].

6. If the O-ring has been removed, moisten the O-ring (Fig. I, Item 19) and insert it into the pump housing or the lantern groove (depending on pump type).



NOTICE

Always make sure that the O-ring (Fig. I, Item 19) is not twisted or squeezed during installation.

7. Insert the motor impeller unit (Fig. 5) into the pump housing in the desired position.

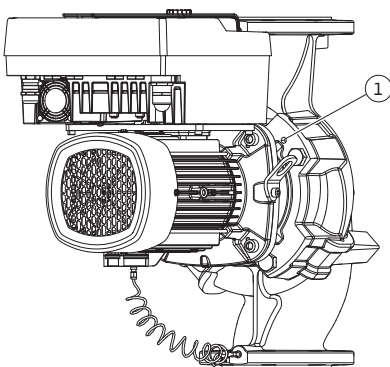

Fig. 14: Pushing off the motor impeller unit via threaded holes (depending on pump type)

8. Screw in the screws (Fig. I to III, Item 29) evenly crosswise, but do not tighten them yet.

CAUTION

Damage due to incorrect handling!

Not screwing the screws in properly can lead to sluggishness of the shaft.

While screwing in the screws, check the rotatability of the shaft with a socket wrench on the fan wheel of the motor (Fig. 6). If necessary, loosen the screws again and tighten them evenly crosswise.

9. Clamp the holder (Fig. I, Item 13) of the differential pressure sensor under one of the screw heads (Fig. I/III, Item 29 and Fig. II, Item 10) on the side opposite the electronic module. Find the optimal position between the laid capillary tubes and DDG cable. Then tighten the screws (Fig. I/III, Item 29 and Fig. II, Item 10).
10. Reconnect the connection cable of the differential pressure sensor (Fig. I, Item 8) or re-store the plugged connection on the differential pressure sensor.

When reinstalling the differential pressure sensor, bend the pressure sensing lines as little as possible and evenly into a suitable position. Do not deform the areas at the clamp boltings. To achieve optimum guidance of the pressure sensing lines, the differential pressure sensor can be separated from the holder (Fig. I, Item 13), rotated 180° around the longitudinal axis and re-installed.



NOTICE

If the differential pressure sensor is turned, do not interchange the discharge and suction sides on the differential pressure sensor!

For additional information about the differential pressure sensor, see "Electrical connection" [► 40] section.

6.4.5 Turning the motor impeller unit (for motor power 11 kW to 22 kW)

The motor impeller unit consists of an impeller, lantern and motor with electronic module.

Turn of motor impeller unit relative to pump housing



NOTICE

To make the installation work easier, it can be helpful to install the pump in the piping. Do not connect the pump electrically or fill the pump or system.

1. Remove the coupling guard (Fig. IV to VI, Item 1.32) using a suitable tool (e.g. screw-driver).
2. Loosen the coupling screws (Fig. IV to VI, Item 1.5) on the coupling unit.
3. Loosen the capillary tube fitting carefully bending it to the side.
4. Loosen the motor fastening screws (Fig. IV to VI, Item 5) on the motor flange and lift the drive off the pump with suitable hoisting gear.
5. By loosening the lantern fastening screws (Fig. IV to VI, Item 4), dismantle the lantern unit with coupling, and possibly the differential pressure sensor, shaft, mechanical seal and impeller from the pump housing.
6. Loosen the impeller fastening nut (Fig. IV to VI, Item 1.11), remove the washer beneath it (Fig. IV to VI, Item 1.12 and 1.15) and pull the impeller (Fig. IV to VI, Item 1.13) from the pump shaft.
7. Dismantle the shim (Fig. VI, Item 1.16) and, if required, the key (Fig. VI, Item 1.43).
8. Pull the mechanical seal (Fig. IV to VI, Item 1.21) off the shaft.
9. Pull the coupling (Fig. IV to VI, Item 1.5) with the pump shaft out of the lantern.
10. Thoroughly clean the sliding/seat surfaces of the shaft. If the shaft is damaged, also replace the shaft.
11. Remove the stationary ring on the mechanical seal with the collar from the lantern flange and the O-ring (Fig. IV to VI, Item 1.14). Clean the gasket seats.



NOTICE

For the following steps, observe the screw tightening torque specified for the respective thread type! See table "Screws and tightening torques [► 34]".

12. Rotate the motor impeller unit by 90° or 180° in the desired direction and install the pump in reverse order.
13. Secure the differential pressure sensor mounting bracket with one of the screws on the side opposite the electronic module. The position of the differential pressure sensor relative to the electronic module does not change.
14. Thoroughly wet the O-ring (Fig. IV to VI, Item 1.14) before installation (do not install the O-ring when it is dry).



NOTICE

Always make sure that the O-ring (Fig. IV to VI, Item 1.14) is not twisted or squeezed during installation.

15. Before commissioning, fill the pump/system and supply it with the system pressure, then check impermeability. In the event of a leakage at the O-ring, air will first escape from the pump. The leakage can be checked with a leakage spray at the gap between the pump housing and the lantern, for example, as well as at their screwed connections.
16. In the event of continual leakage, use a new O-ring, if need be.

CAUTION

Material damage due to bent or kinked pressure sensing lines.

Improper handling can damage the pressure sensing line.

When turning the motor impeller unit, do not bend or kink pressure sensing lines.

17. When reinstalling the differential pressure sensor, bend the pressure sensing lines as little as possible and evenly into a suitable position. When doing this, do not deform the areas at the clamp boltings.

CAUTION

Damage due to incorrect handling!

Not screwing the screws in properly can lead to sluggishness of the shaft.

While screwing in the screws, check the rotatability of the shaft with a socket wrench on the fan wheel of the motor. If necessary, loosen the screws again and tighten them evenly crosswise.



NOTICE

If the differential pressure sensor is turned, do not interchange the discharge and suction sides on the differential pressure sensor!

For additional information about the differential pressure sensor, see section "Electrical connection".

6.4.6 Turning the drive (for motor power 0.37 kW to 7.5 kW)

The drive consists of a motor and an electronic module.

Turn of the drive relative to pump housing

The lantern position is maintained, the air vent valve points upwards.

Turning the drive is only possible for versions according to Fig. II.

For the versions according to Fig. I and Fig. III, only turning the motor impeller unit is possible. See "Turn of motor impeller unit" [► 30] section.



NOTICE

The following work steps provide for dismantling of the mechanical seal. In individual cases, the mechanical seal and the lantern O-ring may be damaged. We recommend that you order a mechanical seal service kit before turning.

An undamaged mechanical seal can be reused.

1. Leave two transport lugs (Fig. I, Item 30) on the motor flange.

2. Attach drive to the transport lugs with suitable lifting equipment for protection. To prevent the unit from tipping, place a belt loop around the motor. When attaching, avoid damaging the electronic module (Fig. 7/8).
3. Realignment may require reversing the orientation of the holder for the fixation of the differential pressure sensor. To do this, loosen and unscrew both screws of the holder (Fig. I, Item 13).
4. Loosen and remove the screws (Fig. II, Item 29).



NOTICE

To unscrew the screws (Fig. II, Item 29), use an open-end spanner, angle spanner or socket wrench with ball head, depending on the type.

5. Press the motor impeller unit (see Fig. 5) off the pump housing. Use the two threaded holes for this (see Fig. 14). Screw M10 screws with a suitable length into the threaded holes to loosen the seat.
6. Place the motor impeller unit including the mounted electronic module on a suitable workstation and secure it.
7. Release the two non-detachable screws from the protective plate (Fig. II, Item 27) and remove the protective plate.
8. Put an open-end wrench with 27 mm width across flats into the lantern window and hold the shaft steady at the wrench flats (Fig. II, Item 16). Unbolt the impeller nut (Fig. II, Item 22). Remove the impeller (Fig. II, Item 21) from the shaft with a puller.
9. Loosen the screw (Fig. II, Item 10) to remove the holder for the differential pressure sensor (Fig. I, Item 13) from the motor flange. Suspend the differential pressure sensor (Fig. I, Item 8) with the holder (Fig. I, Item 13) from the pressure sensing lines (Fig. I, Item 7). Disconnect the connection cable of the differential pressure sensor in the electronic module, if necessary.
10. Loosen and remove the screws (Fig. II, Item 10 and Item 10a).
11. Release the lantern from the motor centring device with a two-arm puller (universal puller) and pull it off the shaft. The mechanical seal (Fig. I, Item 25) will also be removed when this is done. Avoid jamming the lantern.
12. If the mechanical seal has been damaged, push the stationary ring (Fig. I, Item 26) of the mechanical seal out of its seat in the lantern. Insert a new stationary ring in the lantern.



NOTICE

For the following steps, observe the screw tightening torque specified for the respective thread type! See table "Screws and tightening torques" [► 34].

13. Carefully push the lantern over the shaft and position it in the desired alignment to the motor flange. Observe the permitted installation positions of the components when doing this. Secure the lantern to the motor flange with the screws (Fig. II, Item 10 and Item 10a). Tighten the screw for the holder (Fig. II, Item 10) only slightly.
14. Push the undamaged or new mechanical seal (Fig. I, Item 25) onto the shaft.
15. To mount the impeller, insert an open-end wrench with 27 mm width across flats into the lantern window and hold the shaft steady at the wrench flats (Fig. II, Item 16).
16. Install the impeller with lock washer and nut. Avoid damage to the mechanical seal due to jamming.
17. Hold the shaft and tighten the impeller nut to the specified tightening torque (see table "Screws and tightening torques" [► 34]).
18. Remove the open-end wrench and reinstall the protective plate (Fig. II, Item 27).
19. If the O-ring has been damaged: Clean the lantern groove and insert the new O-ring (Fig. II, Item 19).
20. Attach motor impeller unit to the transport lugs with suitable lifting equipment for protection. To prevent the unit from tipping, place a belt loop around the motor. When attaching, avoid damaging the electronic module (Fig. 7/8).
21. Insert the motor impeller unit (Fig. 5) into the pump housing with the air vent valve facing upwards. Observe the permitted installation positions of the components when doing this.
22. Screw in the screws (Fig. II, Item 29).

23. Carefully pull the differential pressure sensor (Fig. I, Item 8) into the planned position and turn it. To do this, touch the capillary tubes (Fig. I, Item 7) at the union points of the differential pressure sensor. Make sure that the capillary tubes are evenly deformed. Secure the differential pressure sensor to one of the screws on the holder (Fig. I, Item 13). Slide the holder under the head of one of the screws (Fig. II, Item 10). Finally, tighten the screw (Fig. II, Item 10).
24. Reconnect the connection cable of the differential pressure sensor.
25. Replace the transport lugs (Fig. I, Item 30) that were moved in step 1.

Tightening torques

Component	Fig./Item screw (nut)	Thread	Tightening torque [Nm] ±10 % (unless otherwise stated)	Installation information
Transport lugs	Fig. I, Item 30	M8	20	
Motor impeller unit for pump housing according to Fig. I	Fig. I, Item 29	M6	10	Tighten evenly and diagonally.
Motor impeller unit or lantern for pump housing according to Fig. II and Fig. III	Fig. II, Item 29 Fig. III, Item 29 Fig. IV to VI, Item 4	M16	100	Tighten evenly and diagonally.
Lantern to Motor	Fig. II, Item 10a Fig. II, Item 10 Fig. IV/V, Item 5 Fig. VI, Item 5 and 6	M6 M12 M8 M10 M12 M16	7 70 25 35 60 100	Small screws first
Cast-iron impeller	Fig. II, Item 21 Fig. III, Item 21 Fig. IV to VI, Item 1.13	M12 M14 M18 M14 M18 M24	60 70 145 70 145 350	Grease thread with Molykote® P37. Hold the shaft with a 27 mm open-end wrench. Block shaft.
Protective plate	Fig. I, Item 27 Fig. IV to VI, Item 1.32	M5	3.5	Disc between protective plate and lantern
Differential pressure sensor	Fig. I, Item 8 Fig. IV to VI, Item 9	Special screw	2	
Capillary tube fitting to the pump housing 0° and 90°	Fig. I, Item 5	R ½" brass	See section "Preparing the installation", Fig. 16	
Capillary tube fitting, union nut 0° and 90°	Fig. I, Item 6	M8x1 brass, nickel-plated	10	Only nickel-plated nut (CV)
Capillary tube fitting, union nut on differential pressure sensor	Fig. I, Item 9	M6x0.75 brass bright	2.4	Only bright brass nuts
Motor adapter for electronic module	Fig. I, Item 4 Fig. V	M6 M6	9 10	Stud and nut

Table 9: Screws and tightening torques

6.5 Preparing the installation



DANGER

Danger of death from falling parts!

The pump itself and pump parts can have a very high net weight. Falling parts pose a risk of cuts, crush injuries, bruises or impacts, which can be fatal.

- Always use suitable lifting accessories and secure parts against falling.
- Never stand below a suspended load.
- During storage and transport, as well as before all installation and assembly work, ensure that the pump is in a safe position and standing securely.



WARNING

Risk of personal injury and property damage due to improper handling!

- Never set up the pump unit on unfortified surfaces or surfaces that cannot bear loads.
- Flush the pipe system if required. Dirt can cause the pump to fail.
- Install only after completion of all welding and soldering work and after the pipe system has been flushed, if required.
- Observe the minimum axial distance of 400 mm between a wall and the fan cover of the motor.
- Ensure free air access to the heat sink of the electronic module.

- The pumps must be protected from the weather and installed in a frost/dust-free, well-ventilated environment that is not potentially explosive. Observe the instructions in “Intended use” section!
- Mount the pump in a readily accessible place. This makes it easier to complete inspections, maintenance (e.g. mechanical seal change) or replacement in the future.
- Install a device for attaching hoisting gear above the set-up site of large pumps. Total weight of the pump: see catalogue or data sheet.



WARNING

Personal injury and property damage due to improper handling!

Transport lugs mounted on the motor housing can tear out if the load is too heavy. This can lead to serious injuries and damage to the product!

- Never transport the entire pump with the transport lugs attached to the motor housing.
- Never use the transport lugs attached to the motor housing to separate or pull out the motor impeller unit.

- Only lift the pump with approved lifting gear (e.g. block and tackle, crane). See also “Transport and storage” section.
- Transport lugs mounted on the motor housing are only permitted for transporting the motor!



NOTICE

Simplify subsequent work on the unit!

- To ensure the entire unit does not have to be emptied, install shut-off valves upstream and downstream of the pump.

CAUTION

Material damage due to turbine and generator operation!

Flowing through the pump in the direction of flow or against the direction of flow can cause irreparable damage to the drive.

Install a swing check valve on the discharge side of each pump!

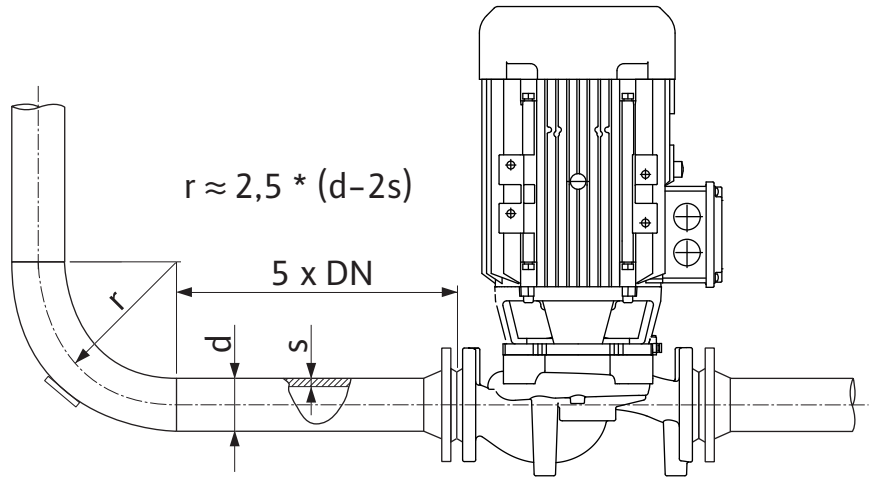

Fig. 15: Settling section upstream and downstream of the pump



NOTICE

Avoid flow cavitation!

- A settling section must be provided upstream and downstream of the pump in the form of a straight pipe. The length of the settling section must be at least 5 times the nominal diameter of the pump flange.

- The pipes and pump must be free of mechanical stress when installed.
- The pipes must be fixed in such a way that the pump does not have to support the weight of the pipes.
- Clean and flush the unit before connecting the pipes.
- The direction of flow must correspond with the direction arrow on the pump flange.
- Venting of the pump is best ensured when the air vent valve is pointing upwards (Fig. 10, Item 1). If the motor shaft is vertical, any orientation is permitted. See also “Permissible installation positions” section.
- Leakages on the clamping ring screw connection (Fig. 1, Item 5/9) can be caused by transportation (e.g. setting behaviour) and handling of the pump (turning the drive, attaching insulation). Turning the clamping ring screw connection by another 1/4 turn resolves the leakage. If the leakage persists after this 1/4 turn, do not turn any further, but replace the screwed connection.

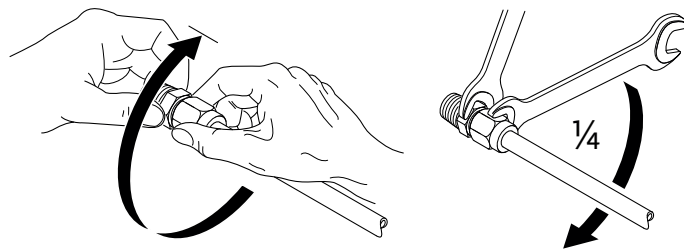

Fig. 16: Further turning the clamping ring screw connection by a 1/4 turn

6.5.1 Permissible forces and torques on the pump flanges

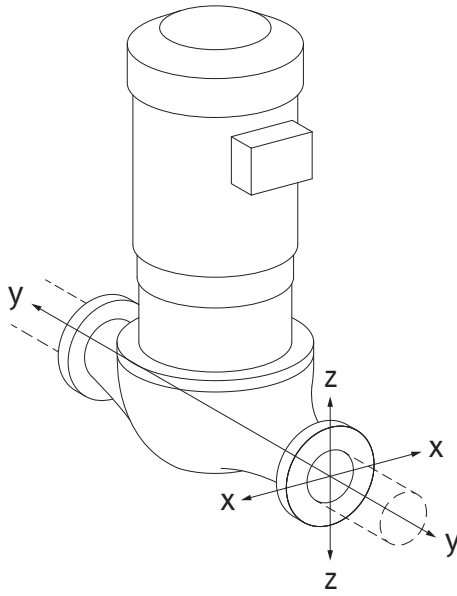

Fig. 17: Load case 16A, EN ISO 5199, Appendix B

Pump suspended in pipe, case 16A (Fig. 17)

DN	Forces F [N]				Torques M [Nm]			
	F _x	F _y	F _z	Σ Forces F	M _x	M _y	M _z	Σ Torques M
Discharge and suction flange								
32	450	525	425	825	550	375	425	800
40	550	625	500	975	650	450	525	950
50	750	825	675	1300	700	500	575	1025
65	925	1050	850	1650	750	550	600	1100
80	1125	1250	1025	1975	800	575	650	1175
100	1500	1675	1350	2625	875	625	725	1300
125	1775	1975	1600	3100	1050	750	950	1525
150	2250	2500	2025	3925	1250	875	1025	1825
200	3000	3350	2700	5225	1625	1150	1325	2400

Values in acc. with ISO/DIN 5199 – class II (2002) – Appendix B

Table 10: Permissible forces and torques on pump flanges in vertical pipe

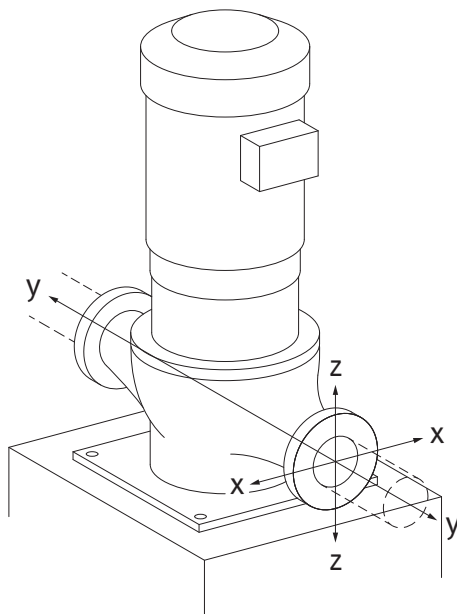

Fig. 18: Load case 17A, EN ISO 5199, Appendix B

Vertical pump on pump support feet, case 17A (Fig. 18)

DN	Forces F [N]				Torques M [Nm]			
	F _x	F _y	F _z	Σ Forces F	M _x	M _y	M _z	Σ Torques M
Discharge and suction flange								
32	338	394	319	619	300	125	175	550
40	413	469	375	731	400	200	275	700
50	563	619	506	975	450	250	325	775
65	694	788	638	1238	500	300	350	850
80	844	938	769	1481	550	325	400	925
100	1125	1256	1013	1969	625	375	475	1050
125	1331	1481	1200	2325	800	500	700	1275
150	1688	1875	1519	2944	1000	625	775	1575
200	2250	2513	2025	3919	1375	900	1075	2150

Values in acc. with ISO/DIN 5199 – class II (2002) – Appendix B

Table 11: Permissible forces and torques on pump flanges in horizontal pipe

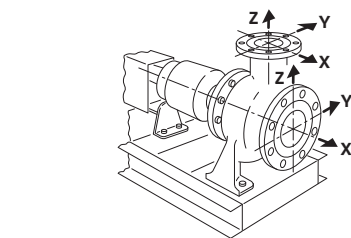

Fig. 19: Load case 1A

Horizontal pump, axial connector x-axis, case 1A

DN	Forces F [N]				Torques M [Nm]			
	F _x	F _y	F _z	Σ Forces F	M _x	M _y	M _z	Σ Torques M
Suction flange								
50	578	525	473	910	490	350	403	718
65	735	648	595	1155	525	385	420	770
80	875	788	718	1383	560	403	455	823
100	1173	1050	945	1838	613	438	508	910
125	1383	1243	1120	2170	735	525	665	1068
150	1750	1575	1418	2748	875	613	718	1278
200	2345	2100	1890	3658	1138	805	928	1680

DN	Forces F [N]				Torques M [Nm]			
	F _x	F _y	F _z	Σ Forces F	M _x	M _y	M _z	Σ Torques M

Values in acc. with ISO/DIN 5199 – class II (2002) – Appendix B

Table 12: Permissible forces and torques on pump flanges

Horizontal pump, top connector z-axis, case 1A

DN	Forces F [N]				Torques M [Nm]			
	F _x	F _y	F _z	Σ Forces F	M _x	M _y	M _z	Σ Torques M

Discharge flange

32	315	298	368	578	385	263	298	560
40	385	350	438	683	455	315	368	665
50	525	473	578	910	490	350	403	718
65	648	595	735	1155	525	385	420	770
80	788	718	875	1383	560	403	455	823
100	1050	945	1173	1838	613	438	508	910
125	1243	1120	1383	2170	735	525	665	1068
150	1575	1418	1750	2748	875	613	718	1278

Values in acc. with ISO/DIN 5199 – class II (2002) – Appendix B

Table 13: Permissible forces and torques on pump flanges

If not all working loads reach the maximum permitted values, one of these loads may exceed the normal limit value. Provided that the following additional conditions are fulfilled:

- All force and torque components are limited to 1.4 times the maximum permitted value.
- The forces and torques acting on each flange meet the requirements of the compensation equation.

$$\left(\frac{\sum |F|_{\text{effective}}}{\sum |F|_{\text{max. permitted}}} \right)^2 + \left(\frac{\sum |M|_{\text{effective}}}{\sum |M|_{\text{max. permitted}}} \right)^2 \leq 2$$

Fig. 20: Compensation equation

$\sum F_{\text{effective}}$ and $\sum M_{\text{effective}}$ are the arithmetic sums of the effective values of both pump flanges (inlet and outlet). $\sum F_{\text{max. permitted}}$ and $\sum M_{\text{max. permitted}}$ are the arithmetic sums of the maximum permitted values of both pump flanges (inlet and outlet). The algebraic signs of $\sum F$ and $\sum M$ are not taken into consideration in the compensation equation.

Influence of material and temperature

The maximum permissible forces and torques apply for the grey cast iron base material and for an initial temperature value of 20 °C.

For higher temperatures, the values must be corrected as follows depending on the ratio of their modulus of elasticity:

$$E_{t, \text{EN-GJL}} / E_{20, \text{EN-GJL}}$$

$E_{t, \text{EN-GJL}}$ = Modulus of elasticity grey cast iron at the selected temperature

$E_{20, \text{EN-GJL}}$ = Modulus of elasticity grey cast iron at 20 °C

6.5.2 Condensate drainage/Insulation

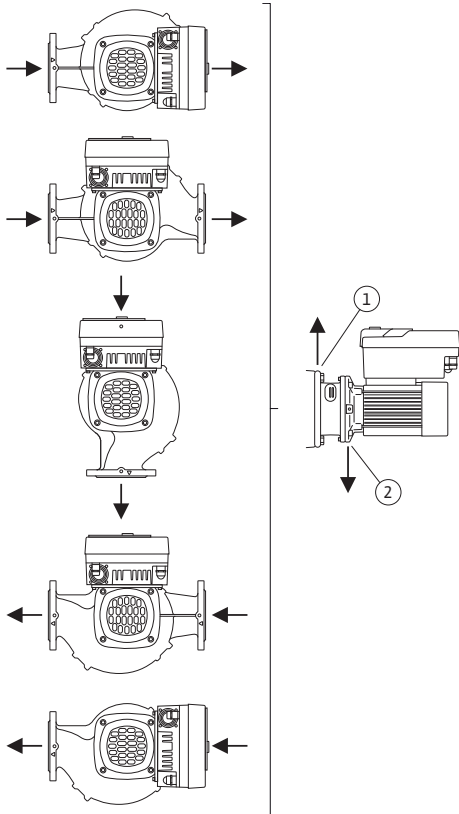

Fig. 21: Permitted installation positions with horizontal shaft

When using the pump in air conditioning systems or chiller plants:

- The condensate that forms in the lantern can be drained specifically via an existing drilled hole. A drain pipe can also be connected to this opening and a small amount of escaping liquid can be drained off.
- The motors are equipped with condensation water holes which are closed with a rubber plug at the factory. The rubber plug is used to guarantee that IP55 rating is fulfilled.
- To allow condensation water to drain off, the rubber plug must be removed downwards.
- With a horizontal motor shaft, the condensate hole must be positioned towards the bottom (Fig. 21, Item 2). If necessary, the motor must be turned.

CAUTION

If the rubber plug is removed, protection class IP55 is no longer ensured!



NOTICE

When systems are insulated, only the pump housing may be insulated. Lantern, drive and differential pressure sensor are not insulated.



NOTICE

Pump housing, lanterns and attached parts (e.g. differential pressure sensor) must be protected against freezing from the outside.

In case of very strong condensation and/or ice formation, any surfaces of the lantern which are very wet with condensate can also be insulated additionally (direct insulation of individual surfaces). Ensure that the condensate drains out of the hole in the lantern.

If service is necessary, the dismantling of the lantern must not be obstructed. The following components must always be freely accessible:

- Air vent valve
- Coupling
- Coupling guard

An insulation material without ammonia compounds must be used as insulation material for the pump. This prevents stress corrosion cracking on the union nuts of the differential pressure sensor. Otherwise, direct contact with the brass screw connections must be avoided. Stainless steel screwed connections are available for this as an accessory. As an alternative, corrosion protection tape (e.g. insulating tape) can also be used.

6.6 Twin-head pump installation/Y-pipe installation

A twin-head pump is a pump housing with two pump drives; two single pumps operated in one Y-piece are a two-pump system.



NOTICE

For twin-head pumps in a twin-head pump housing, the pump on the left in the direction of flow is configured as the main pump at the factory. The differential pressure sensor is mounted on this pump. The Wilo Net bus communication cable is also mounted and configured on this pump at the factory.

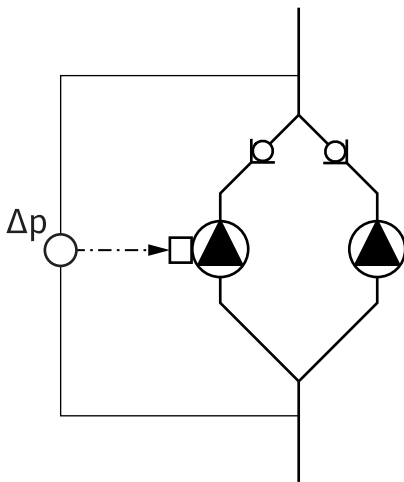

Fig. 22: Example – differential pressure sensor connection in y-pipe installation

6.7 Installation and position of additional sensors to be connected

Two single pumps as two-pump system in Y-piece:

In the example in Fig. 22, the main pump is the left-hand pump in the direction of flow. Connect the differential pressure sensor to this pump!

The two single pumps must be connected and configured to form a two-pump system. See “Operating the pump” [► 54] section and “Dual-pump operation” [► 65] section.

The measuring points of the differential pressure sensor must be on the suction and discharge side of the two-pump system in the corresponding collector pipe.

Index circuit evaluator – hydraulic index circuit in the system:

As delivered, a differential pressure sensor is installed on the flanges of the pump. Alternatively, a differential pressure sensor can also be installed at the hydraulically most unfavourable point in the pipe network. The cable connection is connected to one of the analogue inputs. The differential pressure sensor is configured in the pump menu. Possible signal types on differential pressure sensors:

- 0 ... 10 V
- 2 ... 10 V
- 0 ... 20 mA
- 4 ... 20 mA

7 Electrical connection



DANGER

Risk of fatal injury due to electrical current!

The use of a thermal overload protection is recommended!

Improper conduct when carrying out electrical work can lead to death due to electric shock!

- Electrical connection may only be carried out by a qualified electrician and in accordance with the applicable regulations!
- Adhere to accident prevention regulations!
- Before beginning work on the product, make sure that the pump and drive are electrically isolated.
- Make sure that no one can turn on the power supply again before work is completed.
- Make sure that all energy sources can be isolated and locked. If the pump was switched off by a safety device, it must be secured against switching back on again until the error has been remedied.
- Electrical machines must always be earthed. Earthing must be appropriate for the drive and meet the relevant standards and regulations. Earth terminals and fixation elements must be suitably dimensioned.
- Connection cables must **never** touch the piping, pump or motor housing.
- If it is possible for persons to come into contact with the pump or the pumped fluid, the earthed connection must also be fitted with a residual current circuit breaker.
- Observe the installation and operating instructions for the accessories!



DANGER

Risk of fatal injury due to contact voltage!
Even when enabled, high contact voltages can still be present in the electronic module due to undischarged capacitors. Therefore, work on the electronic module must not be started until 5 minutes have elapsed!

Touching live parts will result in serious injuries or death!

- Before working on the pump, disconnect all poles of the supply voltage and secure against being switched on again! Wait 5 minutes.
- Check whether all connections (including potential-free contacts) are voltage-free!
- Never insert objects (e.g. nail, screwdriver, wire) into openings on the electronic module!
- Reinstall removed safety devices (such as module covers)!



DANGER

Risk of fatal electrical shock! Generator or turbine operation during pump flow!

Even without the electronic module (without electrical connection), there may be dangerous contact voltage at the motor contacts!

- Check for absence of voltage and cover or cordon off adjacent live parts!
- Close the shut-off devices upstream and downstream of the pump!



DANGER

Risk of fatal electrical shock!

Water on the upper part of the electronic module can enter the electronic module when it is opened.

- Before opening, remove water, e.g. on the display, by wiping it off completely. Avoid water penetration in general!



DANGER

Potentially fatal injury due to electronic module not being installed!

A life-threatening voltage may be present at the motor contacts! Normal operation of the pump is only permitted with the electronic module installed.

- Never connect or operate the pump without the electronic module mounted!

CAUTION

Material damage due to improper electrical connection!
An inadequate mains design can lead to system failures and cable fires due to mains overload!

- When designing the mains supply with regard to the used cable cross-sections and fuses, pay special attention to the fact that, in multi-pump operation, it is possible that all pumps operate at the same time for short periods.
-

CAUTION

Danger of material damage caused by improper electrical connection!

- Ensure that the current type and voltage of the mains connection correspond to the specifications on the pump rating plate.
-

Threaded cable glands and threaded cable glands

0.37 kW to 7.5 kW:

There are six cable entries to the terminal box on the electronic module (Fig. 23). The cable for the power supply of the electric fan on the electronic module is mounted at the factory. The requirements for electromagnetic compatibility must be observed.

11 kW to 22 kW:

There are five cable entries to the terminal box on one side of the electronic module (Fig. 24). A cable entry for the power supply is found on the other side. The power supply of the electronic fan on the electronic module is found inside and is factory mounted.



NOTICE

The following are factory mounted:

- For motor power 0.37 to 7.5 kW:
M25 threaded cable gland for the mains connection and M20 threaded cable gland for the cable for the differential pressure sensor/dual-pump communication.
 - For motor power 11 to 22 kW:
M40 threaded cable gland for the mains connection and M20 threaded cable gland for the cable for the differential pressure sensor/dual-pump communication.
 - ▶ All other required threaded cable glands M20 must be provided by the customer.
-

CAUTION

In order to ensure IP55, unoccupied threaded cable glands must remain closed with the plugs provided by the manufacturer.

- When installing the threaded cable gland, make sure that a gasket is installed below the threaded cable gland.
-

1. Screw in threaded cable glands as required. Observe the tightening torque. See “Electronic module tightening torques” [▶ 50] table in the “Turning the display” [▶ 50] section.
2. Make sure that a gasket is fitted between the threaded cable gland and the cable bushing.

The combination of threaded cable gland and cable bushing must be made according to the following “Cable connections” table:

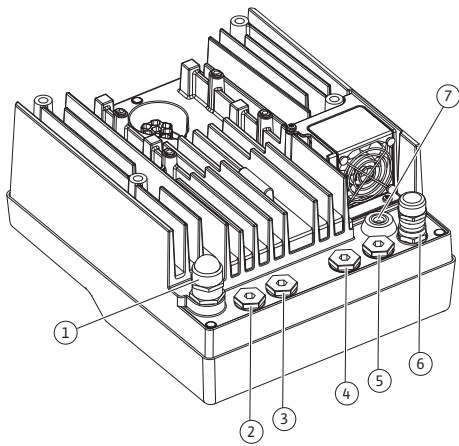

Fig. 23: Threaded cable glands / cable entries (0.37 kW to 7.5 kW)

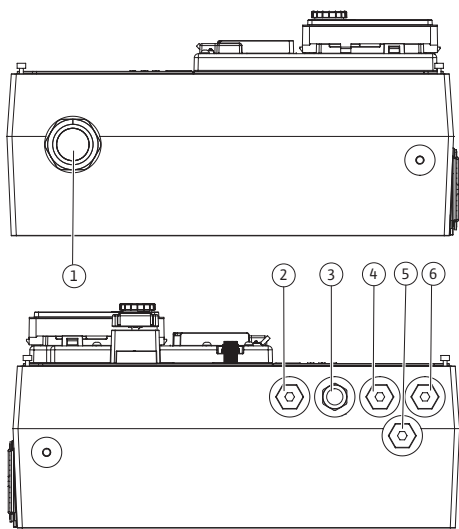

Fig. 24: Threaded cable glands / cable entries (11 kW to 22 kW)

Connection	Threaded cable gland	Cable entry Fig. 23/24, Item	Terminal no.
Electrical mains connection 3~380 V AC to 3~440 V AC 1~220 V AC to 1~240 V AC	Plastic	1	1 (Fig. 25) 4 (Fig. 26)
SSM 1~220 V AC to 1~240 V AC 12 V DC	Plastic	2	2 (Fig. 25) 2 (Fig. 26)
SBM 1~220 V AC to 1~240 V AC 12 V DC	Plastic	3	3 (Fig. 25) 2 (Fig. 26)
Digital input 1 (only EXT. OFF) (24 V DC)	Metal with shielding	4, 5, 6	11 To 12 (Fig. 27), DI1
Bus Wilo Net (bus communication)	Metal with shielding	4, 5, 6	15 to 17 (Fig. 27)
Analogue input 1 0 to 10 V, 2 to 10 V, 0 to 20 mA, 4 to 20 mA (differential pressure sensor only)	Metal with shielding	4, 5, 6	1, 2, 3 (Fig. 27)
Analogue input 2 0 to 10 V, 2 to 10 V, 0 to 20 mA, 4 to 20 mA (External setpoint sensor)	Metal with shielding	4, 5, 6	4, 5 (Fig. 27)
CIF module (bus communication)	Metal with shielding	4, 5, 6	
Electrical connection of the fan (depending on type) (0.37 kW to 7.5 kW) Assembled at the factory (24 V DC)		7	4 (Fig. 25)
Electrical connection of the fan (11 kW to 22 kW) Assembled at the factory (24 V DC)		-	1 (Fig. 26)

Table 14: Cable connections

Cable requirements

Terminals are intended for rigid and flexible conductors with or without ferrules. If flexible cables are used, wire end ferrules must be used.

Connection	Terminal cross-section in mm ² Min.	Terminal cross-section in mm ² Max.	Cable
Electrical mains connection 3~	≤ 4 kW: 4x1.5 5.5 ... 7.5 kW: 4x4 11 kW: 4x4 15 kW: 4x6 18.5 kW to 22 kW: 4x10	≤ 4 kW: 4x4 5.5 ... 7.5 kW: 4x6 11 kW to 22 kW: 4x16	
Electrical mains connection 1~	≤ 1.5 kW: 3x1.5	≤ 1.5 kW: 3x4	
SSM	2x0.2	3x1.5 (1.0**) changeover relay	*

Connection	Terminal cross-section in mm ² Min.	Terminal cross-section in mm ² Max.	Cable
SBM	2x0.2	3x1.5 (1.0 ^{**}) changeover relay	*
Digital input 1 EXT. OFF	2x0.2	2x1.5 (1.0 ^{**})	*
Analogue input 1	2x0.2	2x1.5 (1.0 ^{**})	*
Analogue input 2	2x0.2	2x1.5 (1.0 ^{**})	*
Wilo Net	3x0.2	3x1.5 (1.0 ^{**})	Shielded
CIF module	3x0.2	3x1.5 (1.0 ^{**})	Shielded

*Cable length ≥ 2 m: Use shielded cables.

**When using ferrules, the maximum cross-section at the terminals of the communication interfaces is reduced to 0.25 to 1 mm².

Table 15: Cable requirements

In order to comply with electromagnetic compatibility standards, the following cables must always be shielded:

- Cable for EXT. OFF at digital inputs
- External control cable sensors at analogue inputs
- Differential pressure sensor (DDG) at analogue inputs, if installed on-site
- Two-pump cable with two single pumps in the Y-piece (bus communication)
- CIF module to the building automation (bus communication)

The shield is connected to the cable bushing on the electronic module. See Fig. 31.

Terminal connections

Terminal connections for all cable connections in the electronic module correspond to push-in technology. They can be opened with a screwdriver type slot SFZ 1 – 0.6 x 0.6 mm.

Length of cable to strip

The stripping length of the cables for the terminal connection is 8.5 mm to 9.5 mm.

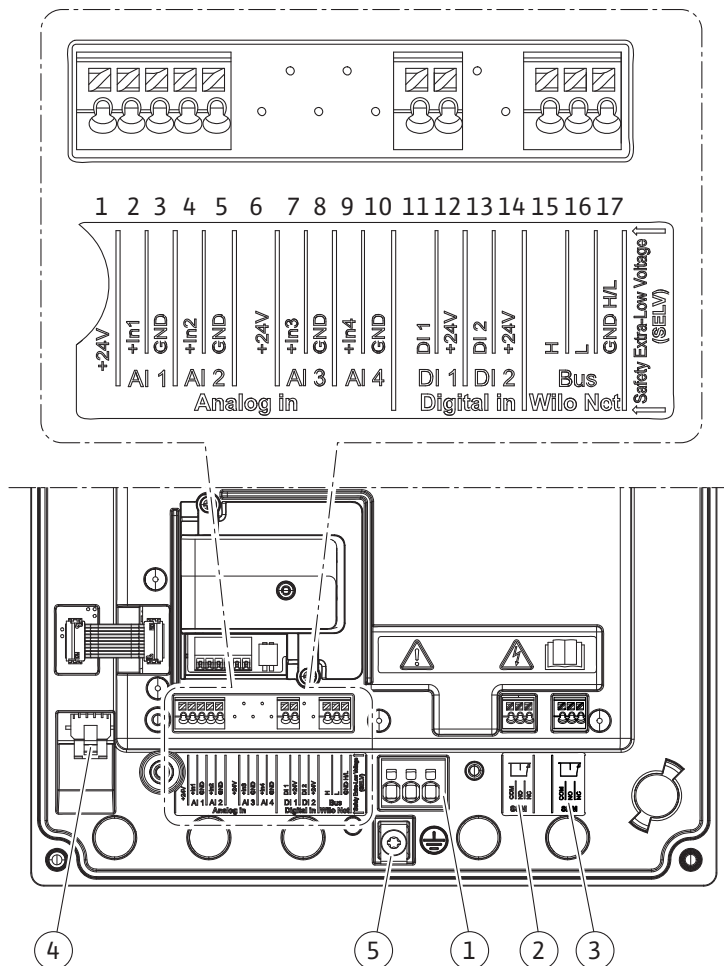

Fig. 25: Overview of terminals in the module (0.37 kW to 7.5 kW)

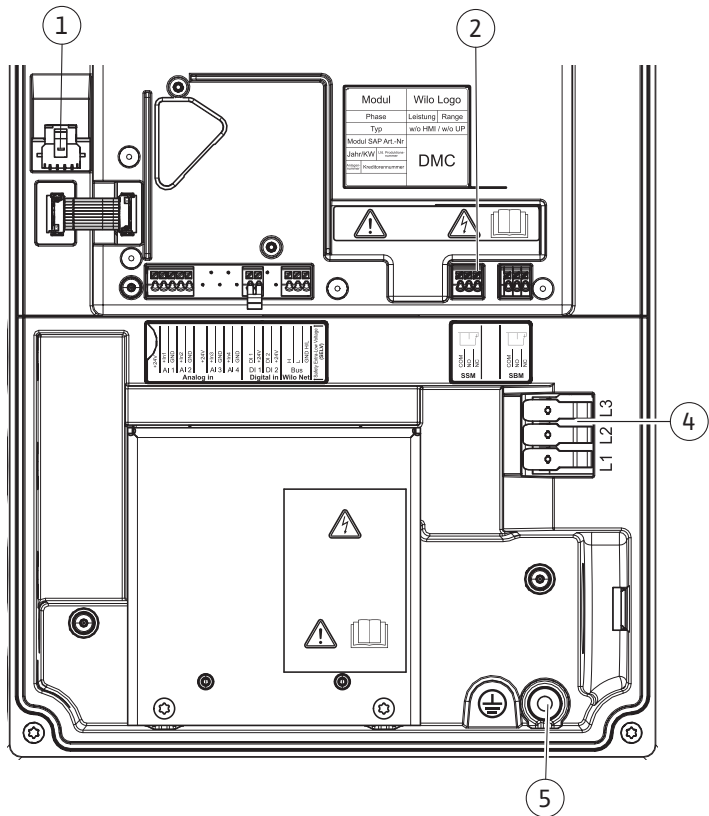

Fig. 26: Overview of terminals in the module (11 kW to 22 kW)

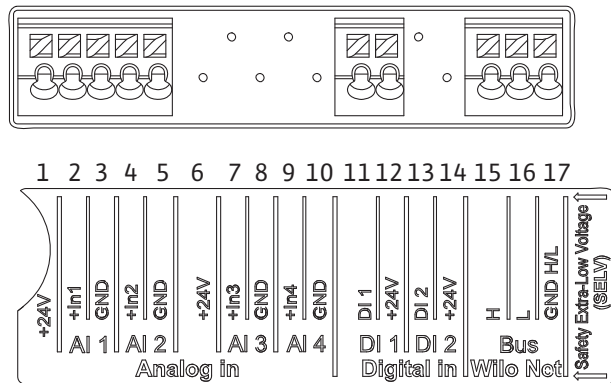

Fig. 27: Terminals for analogue inputs, digital inputs and Wilo Net



NOTICE

AI3 and AI4 (terminals 6 to 10) and DI2 (terminals 13 and 14) are not assigned.

Terminal assignment

Designation	Assignment	Note
Analogue IN (AI1) (Fig. 27)	+ 24 V (terminal: 1)	Type of signal:
	+ In 1 → (terminal: 2)	• 0 to 10 V
Analogue IN (AI2) (Fig. 27)	- GND (terminal: 3)	• 2 to 10 V
	+ In 2 → (terminal: 4)	• 0 to 20 mA
	- GND (terminal: 5)	• 4 to 20 mA
		Electric strength: 30 V DC / 24 V AC
		Power supply: 24 V DC: at maximum 50 mA

Designation	Assignment	Note
Digital IN (DI1) (Fig. 27)	DI1 → (terminal: 11) + 24 V (terminal: 12)	Digital input for potential-free contacts: <ul style="list-style-type: none"> • Maximum voltage: < 30 V DC / 24 V AC • Maximum loop current: < 5 mA • Operating voltage: 24 V DC • Operating loop current: 2 mA per input
Wilo Net (Fig. 27)	↔ H (terminal: 15) ↔ L (terminal: 16) GND H/L (terminal: 17)	
SSM (Fig. 30)	COM (terminal: 18) ← NO (terminal: 19) ← NC (terminal: 20)	Potential-free changeover contact Contact load: <ul style="list-style-type: none"> • Permitted minimum: SELV 12 V AC / DC, 10 mA • Permitted maximum: 250 V AC, 1 A, 30 V DC, 1 A
SBM (Fig. 30)	COM (terminal: 21) ← NO (terminal: 22) ← NC (terminal: 23)	Potential-free changeover contact Contact load: <ul style="list-style-type: none"> • Permitted minimum: SELV 12 V AC / DC, 10 mA • Permitted maximum: 250 V AC, 1 A, 30 V DC, 1 A
Mains connection Fig. 25, Item 1 Fig. 26, Item 4		
Earthing screw Fig. 25 and 26, Item 5		

Table 16: Terminal assignment

7.1 Mains connection



NOTICE

Nationally applicable guidelines, standards and regulations as well as the requirements of local energy supply companies must be observed!



NOTICE

Tightening torques for the terminal screws, see “Tightening torques” [► 34] table. Only use a calibrated torque wrench!

1. Observe the current type and voltage on the rating plate.
2. Establish the electrical connection via a fixed connection cable equipped with a connector device or an all-pole switch with a contact opening width of at least 3 mm.
3. To protect against leakage and for strain relief to the threaded cable gland, use a connection cable with sufficient outer diameter.
4. Lead connection cable through the M25 threaded cable gland (Fig. 23, Item 1, for 0.37 kW to 7.5 kW).
Lead connection cable through the M40 threaded cable gland (Fig. 24, Item 4, for 11 kW to 22 kW).
Tighten the threaded cable gland with the specified torque.
5. Bend the cables near the screwed connection to form a drain loop to drain any accumulated drips.
6. Lay the connection cable in such a way that it touches neither the pipes nor the pump.
7. Use a heat-resistant connection cable if fluid temperatures exceed 90 °C.



NOTICE

If flexible cables are used for the mains connection or communication connection, use wire end ferrules!

Non-assigned threaded cable glands must remain sealed with the plugs provided by the manufacturer.



NOTICE

In regular operation, it's better to switch the pump on or off instead of switching the mains voltage. This is done via the digital input EXT. OFF.

Mains terminal connection (0.37 kW to 7.5 kW)

Line terminal for 3~ mains connection with earthing

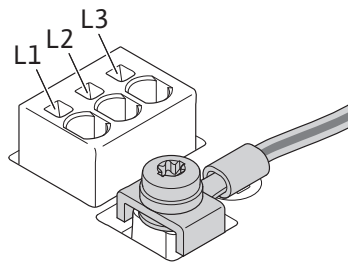

Line terminal for 1~ mains connection with earthing

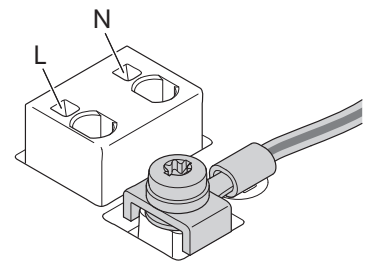

Direct current connection (0.37 kW to 7.5 kW)

When using a flexible connection cable, use a ring lug for the earthing wire (Fig. 28).

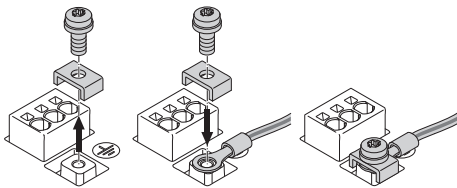

Fig. 28: Flexible connection cable

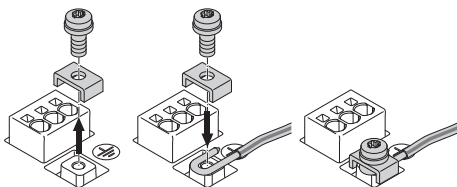
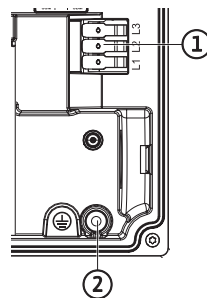

Fig. 29: Rigid connection cable

When using a rigid connection cable, connect the earthing wire in a U-shape (Fig. 29).

Mains terminal connection (11 kW to 22 kW)

Line terminal for 3~ mains connection with earthing



Direct current connection (11 kW to 22 kW)

For a flexible connection cable, use a ring lug for the earth wire.

For a rigid connection cable, connect the earth wire in a U-shape.

Residual-current device (RCD)



Observe the following when installing RCDs:

A universal-current-sensitive RCD type B is mandatory for frequency converters. Standard RCDs (type A) are not permitted, as frequency converters can cause residual currents that negatively affect the standard RCDs (type A).



NOTICE

This product can cause direct current in the protective earth conductor. If a residual-current device (RCD) or a residual-current monitoring device (RCM) is used for protection in the event of direct or indirect contact, only a type B RCD or RCM is permitted on the power-supply side of this product.

- Labelling:   
- Trigger current: > 30 mA

Fuse protection on mains side: max. 25 A (for 3~ 0.55 kW to 11 kW)

Fuse protection on mains side: max. 35 A (for 3~ 15 kW)

Fuse protection on mains side: max. 50 A (for 3~ 18.5 kW to 22 kW)

Fuse protection on mains side: max. 16 A (for 1~ 0.37 kW to 1.5 kW)

The mains-side fuse protection must correspond to the electrical configuration of the pump.

Circuit breaker

The use of a circuit breaker is recommended.



NOTICE

Circuit breaker trigger characteristic: B

Overload: $1.13 - 1.45 \times I_{nom}$

Short-circuit: $3 - 5 \times I_{nom}$

7.2 SSM and SBM connection

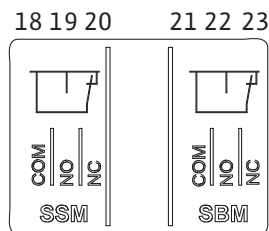

Fig. 30: Terminals for SSM and SBM

SSM (collective fault signal) and SBM (collective run signal) are connected to terminals 18 ... 20 and 21 ... 23.

The cables of the electrical connection for SBM and SSM do **not** have to be shielded.



NOTICE

A maximum of 230 V may be applied between the contacts of the relays of SSM and SBM, never 400 V!

When using 230 V as a switching signal, the same phase must be used between the two relays.

7.3 Connection of digital, analogue and bus inputs

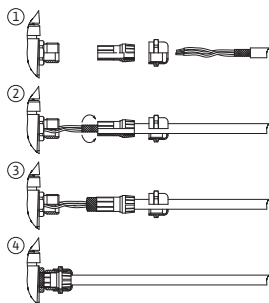

Fig. 31: Shield clamp

SSM and SBM are designed as changeover contacts and can each be used as a normally open contact or normally closed contact. When the pump is voltage-free, the contact is normally closed contact. The following applies to SSM:

- If a fault is present, the contact at NC is normally open contact.
- The converter bridge to NO is closed.

The following applies to SBM:

- Depending on the configuration, the contact is set to NO or NC.

The cables of the digital input, the analogue inputs and the bus communication must be shielded via the metal threaded cable gland of the cable entry (Fig. 23, Items 4, 5 and 6). For shielding, see Fig. 31.

When used for extra-low voltage cables, up to three cables can be passed through for each threaded cable gland. Use the appropriate multiple sealing inserts for this purpose.



NOTICE

Threaded cable glands M20 and seal inserts must be provided on-site.



NOTICE

If two cables are to be connected to one 24 V supply terminal, provide a solution on-site!

Only one cable per terminal may be connected to the pump!

**NOTICE**

The terminals of the analogue inputs, digital inputs and Wilo Net meet the “safe isolation” requirement (according to EN 61800-5-1) to the mains terminals, the terminals SBM and SSM (and vice versa).

**NOTICE**

The control is designed as a SELV (Safe Extra Low Voltage) circuit. In this way, the (internal) supply fulfils the requirements for safe separation of the supply. GND is not connected to PE.

**NOTICE**

The pump can be switched on and off without intervention from the operator. This can be done, for example, using the control function, by external BMS connection or also by the EXT. OFF function.

7.4 Differential pressure sensor connection

If pumps are delivered with a differential pressure sensor fitted, it is connected to analogue input AI 1 at the factory.

If the differential pressure sensor is connected on-site, carry out the cable assignment as follows:

Cable	Colour	Terminal	Function
1	Brown	+24 V	+24 V
2	Black	In1	Signal
3	Blue	GND	Earth

Table 17: Connection; differential pressure sensor cable

**NOTICE**

For a twin-head pump or Y-pipe installation, connect the differential pressure sensor to the main pump! The measuring points of the differential pressure sensor must be on the suction and discharge side of the twin-head pump system in the common collector pipe. See “Twin-head pump installation/Y-pipe installation” [► 39] section.

7.5 Wilo Net connection for twin-head pump function

Wilo Net is a Wilo system bus used for establishing communication between Wilo products:

- Two single pumps as a twin-head pump in the Y-piece or one twin-head pump in a twin-head pump housing

**NOTICE**

For Yonos GIGA2.0-D, the Wilo Net cable for twin-head pump communication is factory-fitted to both electronic modules.

In order to establish the Wilo Net connection, the three **H, L, GND** terminals must be wired with a communication cable from pump to pump.

Incoming and outgoing cables are clamped in a terminal.

Cable for Wilo Net communication:

To ensure interference immunity in industrial environments (IEC 61000-6-2), use a shielded CAN bus cable and an EMC-compatible cable entry for the Wilo Net cables. Connect the shield to earth at both ends. For optimum transmission, the data cable pair (H and L) must be twisted at Wilo Net and have a characteristic impedance of 120 ohms.

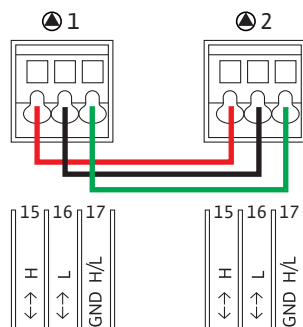

Pump	Wilo Net termination	Wilo Net address
Pump 1	switched on	1
Pump 2	switched on	2

Table 18: Wilo Net cabling

Number of Wilo Net participants:

For twin-head pumps, the Wilo Net consists of two participants, with each individual node counting as a participant.

- Twin-head pump = 2 participants (e.g. ID 1 and 2)

For further descriptions, see “Application and function of the Wilo Net interface” [► 85] section.

7.6 Turn of the display

CAUTION

If the graphic display is not fixed properly and the electronic module is not installed correctly, protection class IP55 is no longer ensured.

- Ensure that no gaskets are damaged!

The graphic display can be turned in 90° steps. To do this, open the upper part of the electronic module using a screwdriver.

The graphic display is fixed in position by two snap-in hooks.

1. Carefully open the snap-in hooks with a tool (e.g. screwdriver).
2. Turn the graphic display to the desired position.
3. Fix the graphic display with the snap-in hooks.
4. Fit the upper part of the module again. Observe the screw tightening torques on the electronic module.

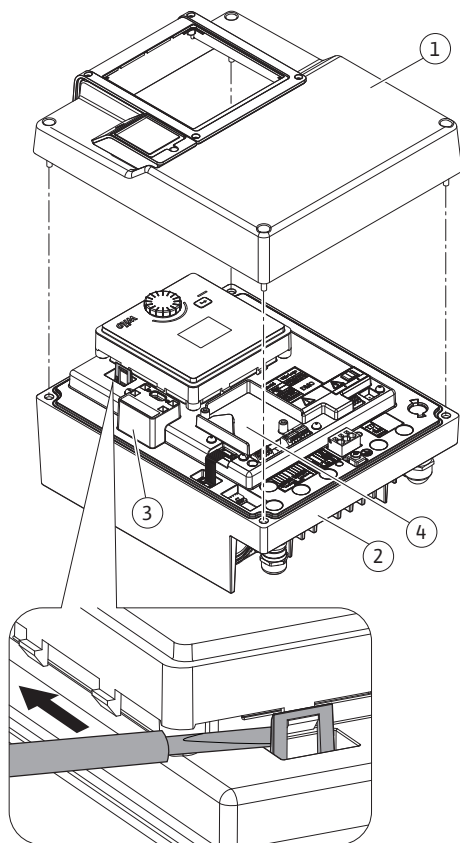

Fig. 32: Electronic module

Component	Fig./Item screw (nut)	Screw drive/thread	Tightening torque [Nm] ±10 % (unless otherwise stated)	Installation information
Electronic module upper part	Fig. 32, Item 1 Fig. I, Item 2	Torx 25/M5	4.5	
Union nut of threaded cable gland (0.37 kW to 7.5 kW)	Fig. 23, Item 1	External hexagon socket/M25	11	*
Threaded cable gland (0.37 kW to 7.5 kW)	Fig. 23, Item 1	External hexagon socket/M25x1.5	8	*
Union nut of threaded cable gland (11 kW to 22 kW)	Fig. 24, Item 1	External hexagon socket/M40	5	*
Threaded cable gland (11 kW to 22 kW)	Fig. 24, Item 1	External hexagon socket/M40x1.5	5	

Component	Fig./Item screw (nut)	Screw drive/thread	Tightening torque [Nm] ±10 % (unless otherwise stated)	Installation information
Threaded cable gland union nut	Fig. 23/24, Item 6	External hexagon socket/M20	6	
Threaded cable gland	Fig. 23/24, Item 6	External hexagon socket/M20x1.5	5	
Power terminals and control terminals	Fig. 25	Pusher		**
Earthing screw (0.37 kW to 7.5 kW)	Fig. 25, Item 5	IP10 slot 1/M5	4.5	
Earthing screw (11 kW to 22 kW)	Fig. 26, Item 5	Combination slot – PH3/6	3	
CIF module	Fig. 32, Item 4	IP10/PT 30x10	0.9	
Wilo-Connectivity Interface cover	Fig. 1, Item 8	Internal hexagon socket/M3x10	0.6	
Module fan (0.37 kW to 7.5 kW)	Fig. 118	IP10/AP 40x12/10	1.9	
Module fan (11 kW to 22 kW)	Fig. 121	IP10/AP 40x12/10	1.2	
EMC protective plate	Fig. 113	Torx 25/M5	4.5	

Table 19: Tightening torques for electronic module

*Tighten when installing the cables.

**Press with screwdriver to plug and unplug the cable.

8 Installation of CIF module



DANGER

Risk of fatal electrical shock!

Immediate danger of death if live components are touched!

- Check whether all connections are voltage-free!

CIF modules (accessories) are used for communication between pumps and building management systems. CIF modules are plugged into the electronic module (Fig. 26, Item 4).

- For twin-head pumps, only the main pump must be equipped with a CIF module.
- For pumps in Y-pipe applications in which the electronic modules are connected to each other through the Wilo Net, only the main pump also requires a CIF module.



NOTICE

When using CIF module Ethernet, the use of the accessory “Connection M12 RJ45 CIF-Ethernet” is recommended.

Required for easy disconnection of the data cable connection via the SPEEDCON socket outside of the electronic module when maintenance of the pump is required.



NOTICE

Explanations on commissioning as well as application, function and configuration of the CIF module on the pump are described in the installation and operating instructions for the CIF modules.

9 Commissioning

- Electrical work: a qualified electrician must carry out the electrical work.
- Installation/dismantling: The technician must be trained in the use of the necessary tools and fixation materials.

- The product must be operated by persons who have been instructed on how the complete system functions.



DANGER

Danger of death due to lack of protective devices!

Due to missing protective devices of the electronic module or in the range of the coupling/motor, electric shock or contact with rotating parts can lead to life-threatening injuries.

- Before commissioning, protection devices such as electronic module covers or coupling covers that were removed must be reinstalled!
- An authorised technician must check the functionality of the safety devices on the pump, motor and electronic module prior to commissioning!
- Never connect the pump without the electronic module!



WARNING

Danger of injury due to fluid shooting out and components coming loose!

Not installing the pump/system correctly can lead to serious injuries during commissioning!

- Carry out all work carefully!
- Keep a safe distance during commissioning!
- Always wear protective clothing, safety gloves and safety glasses when working.

9.1 Filling and venting

CAUTION

Dry running will destroy the mechanical seal! It may cause leakage.

- Ensure that a dry run of the pump is not possible.



WARNING

There is a risk of burns or freezing upon coming into contact with the pump/system.

Depending on the pump and system operating conditions (fluid temperature), the entire pump can become very hot or very cold.

- Keep a safe distance during operation!
- Allow the system and pump to cool down to room temperature!
- Always wear protective clothing, safety gloves and safety glasses when working.



DANGER

Danger of personal injury and material damage due to extremely hot or extremely cold pressurised fluid!

Depending on the temperature of the fluid, when the venting device is opened completely, **extremely hot** or **extremely cold** fluid may escape in liquid or vapour form. Fluid may shoot out at high pressure depending on the system pressure.

- Always exercise caution when opening the venting device.
- Protect the electronic module from any water escaping when venting.

1. Fill and vent the system correctly.
2. In addition, loosen the air vent valves (Fig. I, Item 28) and vent the pump.

3. After venting the pump, tighten the air vent valves again so that no more water can escape.

CAUTION

Destruction of the differential pressure sensor!

- Never vent the differential pressure sensor!
-



NOTICE

- Always keep to the minimum pressure!
-

- To avoid cavitation noises and damage, a minimum inlet pressure must be guaranteed at the suction port of the pump. The minimum inlet pressure depends on the operating situation and the pump's duty point. Accordingly, the minimum pressure must be determined.
 - The main parameters for defining the minimum inlet pressure are the NPSH value of the pump at its duty point and the vapour pressure of the fluid. The NPSH value can be found in the technical documentation of the respective pump type.
-



NOTICE

When pumping from an open tank (e.g. cooling tower), ensure that there is always a sufficient liquid level above the pump's suction port. This prevents the pump from running dry. The minimum inlet pressure must be observed.

9.2 Procedure after switching on the power supply during initial commissioning

As soon as the power supply is switched on, the display starts. This can take a few seconds. After the start-up process has been completed, settings can be configured (see "Control settings" [▶ 61] section).
At the same time, the motor starts running.

CAUTION

Dry running will destroy the mechanical seal! It may cause leakage.

- Ensure that a dry run of the pump is not possible.
-

Preventing the motor from starting when the power supply is switched on during initial commissioning:

A cable jumper is set at the digital input DI1 in the factory. DI1 is factory-set as EXT. OFF is activated.

To prevent the motor from starting during initial commissioning, the cable bridge must be removed before the power supply is switched on for the first time.

After initial commissioning, the digital input DI1 can be set as required via the initialised display.

If the digital input is switched to inactive, the cable bridge does not have to be set again to start the motor.

When the digital input DI1 is reset to the factory setting, it is active again. The pump will not start without the cable bridge. See "Application and function of the digital control input" [▶ 76] section.

9.3 Description of operating elements

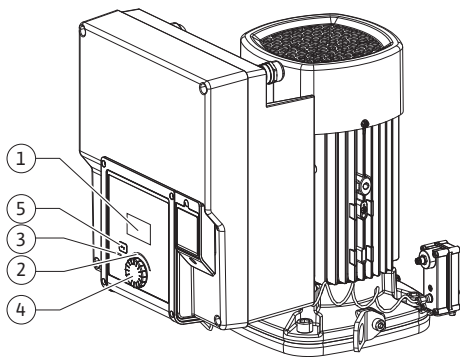

Fig. 33: Operating elements

Item	Name	Explanation
1	Graphic display	Provides information about settings and pump status. User interface for setting the pump.
2	Green LED indicator	LED is lit up: Pump is supplied with voltage and ready for operation. There are no warnings and no faults.
3	Blue LED indicator	LED is lit up: Pump is influenced externally via an interface, e.g. by: <ul style="list-style-type: none"> • Setpoint setting via analogue input AI1 ... AI2 • Intervention of building automation via digital input DI1 or bus communication Flashes with active twin-head pump connection.
4	Operating button	Navigate menus and edit content by turning and pressing.
5	Back button	Menu navigation: <ul style="list-style-type: none"> • To go back to the previous menu level (briefly press once). • To go back to the previous settings (briefly press once). • To return to the main menu (press 1 x longer, > 2 seconds) Switches the key lock* on or off (> 5 seconds) in combination with pressing the operating button.

Table 20: Description of operating elements

*The configuration of the key lock makes it possible to prevent the pump setting from being changed on the display.

9.4 Pump operation

9.4.1 Setting of pump output

The system was designed for a certain duty point (full load point, calculated maximum heating or cooling power demand). During commissioning, the pump output (delivery head) is set according to the duty point of the system.

The factory setting does not correspond to the output required for the system. The required pump capacity is determined with the help of the pump curve diagram for the selected pump type (e.g. from the data sheet).



NOTICE

For water applications, the flow rate value shown in the display or output to the building management system applies. For other fluids, this value only reflects the tendency. If no differential pressure sensor is installed (variant ... R1), the pump cannot indicate a volume flow value.

CAUTION

Risk of material damage!

An inadequate volume flow can lead to damage on the mechanical seal; the minimum volume flow depends on the speed of the pump.

- Make sure that the volume flow does not fall below the minimum value Q_{min} .

Approximate calculation of Q_{min} :



$$Q_{min} = 10 \% \times Q_{max \text{ pump}} \times \text{actual speed} / \text{max. speed}$$

9.4.2 Settings on pump

Carry out settings by turning and pressing the operating button. Turn the operating button to the left or right to browse the menus or configure settings. A green focus indicates navigation in the menu. A yellow focus indicates a configuration of settings.

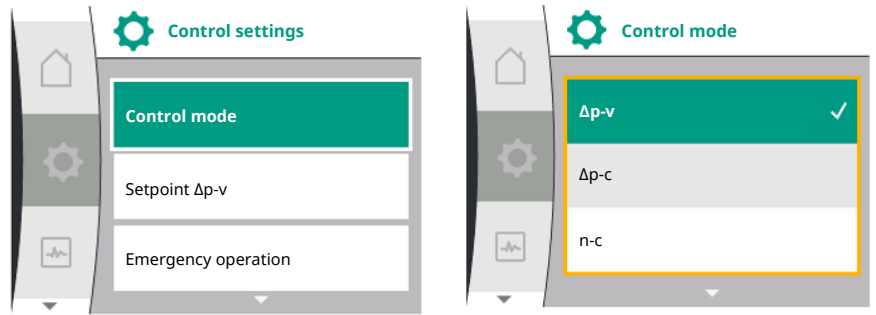
- Green focus: Navigation in menu.
- Yellow focus: Change settings.



- Turn : menu selection and parameter setting.
- Press : Activation of menus or confirming settings.

Press the “Back” button  (“Description of operating elements” [► 54] table) to change the focus back to the previous focus. Consequently, the focus moves one level further up in the structure or to a previous setting.

Pressing the Back button  after having changed a setting (yellow focus) without confirming the changed value returns the focus to the previous focus. The adjusted value will be discarded. The previous value remains unchanged.

If the Back button  is pressed for more than 2 seconds, the Home screen opens and the pump can be operated from the main menu.



NOTICE

If there are no warning or error messages, the display on the electronic module will switch off 2 minutes after the last time it was operated.

- If the operating button is pressed or turned again within 7 minutes, the previously exited menu will appear. You can continue to configure settings.
- If the operating button is not pressed or turned for more than 7 minutes, any unconfirmed settings will be lost. Pressing the button again opens the Home screen on the display and the pump can be operated from the main menu.

9.4.3 Initial settings menu

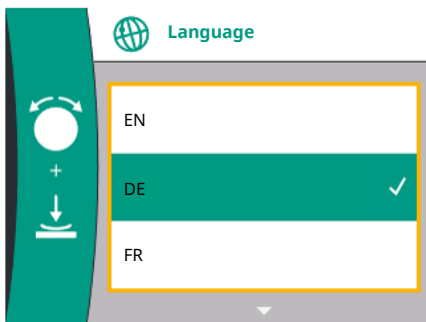

Fig. 34: Initial settings menu

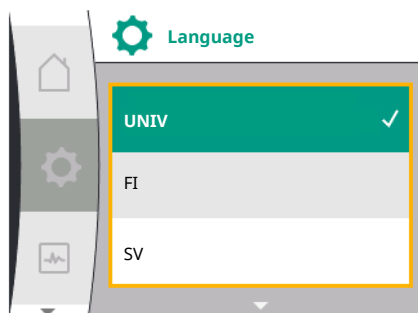

Fig. 35: Menu language

The settings menu will appear in the display during initial commissioning of the pump. Turn the operating button to display the different menu languages. The following languages can be selected:

Language abbreviations	Language
EN	English
DE	German
FR	French
IT	Italian
ES	Spanish
UNIV	Universal
FI	Finnish
SV	Swedish
PT	Portuguese
NO	Norwegian
NL	Dutch
DA	Danish
PL	Polish
HU	Hungarian
CS	Czech
RO	Romanian
SL	Slovenian
HR	Croatian

Language abbreviations	Language
SK	Slovak
SR	Serbian
LT	Latvian
LV	Lithuanian
ET	Estonian
RU	Russian
UK	Ukrainian
BG	Bulgarian
EL	Greek
TR	Turkish

Table 21: Menu languages



NOTICE

In addition to the languages, there is a neutral number code “Universal” in the display that can be selected as an alternative language. The number code is listed and explained in tables next to the display texts.

Factory setting: English



NOTICE

After selecting a language other than the one currently set, the display may switch off and restart.

The green LED flashes during this process. After the display has restarted, the language selection list opens with the activated newly selected language.

This process can take up to approx. 30 sec.

After selecting the language, the initial setting menu is exited. The display changes to the main menu.

If no settings are made, the pump starts in factory setting ($\Delta p-v$).

For further factory settings, see “Factory setting” [► 96] section.



NOTICE

The factory setting for variant ... R1 (without differential pressure sensor in delivery status) is the basic control mode “Constant speed”. The factory setting mentioned below refers to the variant with a differential pressure sensor fitted in the factory.

9.4.4 Main menu

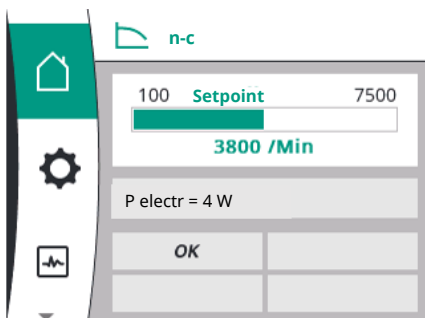

Fig. 36: Main menu

9.4.5 Main menu “Home screen”

Meaning of the main menu symbols in the display

	Universal	Display text
	Homescreen	Homescreen
	1.0	Settings
	2.0	Diagnostics and measured values
	3.0	Factory setting

The selection of the home screen is done by turning the operating button to the “House” symbol.

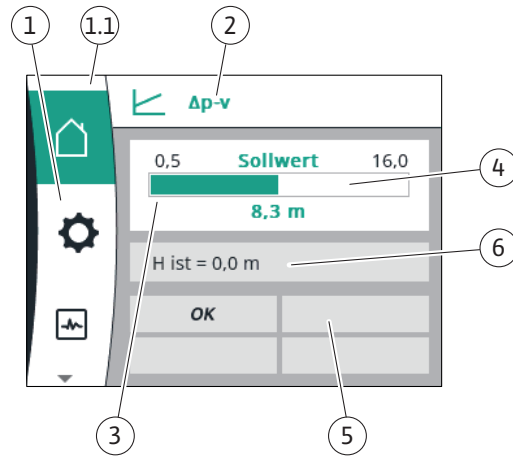

Fig. 37: Home screen

Item	Name	Explanation
1	Main menu overview	Selection of different main menus
1.1	Status area: Error, warning or process information display	Indicates an on-going process, warning or error message. Blue: Process or communication status display (CIF module communication) Yellow: Warning Red: Fault Grey: There are no processes running in the background, there are no warning or error messages.
2	Title bar	Display of the currently set control mode.
3	Setpoint display field	Displays currently configured setpoints.
4	Setpoint editor	Yellow frame: You have pressed the operating button to open the setpoint editor and change the value.
5	Active influences	Display of influences on set control mode, E.g. EXT. OFF. Up to four active influences can be displayed. If a twin-head pump connection is set up, the status of the twin-head pump is displayed here.
6	Operating data and measurement area	Shows current operating data and measured values. The displayed operating data depend on the set control mode. They are displayed alternately.

Table 22: Home screen

Setpoints can be changed in the “Home screen” menu.

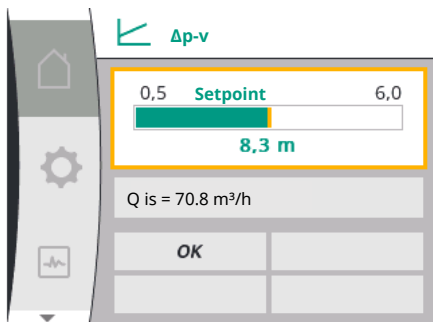



Fig. 38: Home screen setpoint adjustment Δp-v



Pressing the operating button activates the setpoint adjustment. The frame of the changeable setpoint turns yellow.

The setpoint is changed by turning the operating button right or left. Pressing the operating button again confirms the changed setpoint. The pump accepts the value and the display returns to the main menu.

Pressing the back button  without confirming the changed setpoint will not change the setpoint. The pump shows the main menu with unchanged setpoint.

Active influences of the pump status on the display in the home screen for single pumps

The active influences are listed from highest to lowest priority:

Name	Displayed symbols	Description
Fault		Error active, motor stops
Pump kick		Pump kick active
EXT.OFF	OFF	Digital input DI EXT. OFF active

Name	Displayed symbols	Description
Pump operation OFF	OFF	Pump manually switched off
Setpoint OFF	OFF	Analogue signal OFF
Substitute speed		Pump is running at substitute speed
Fallback Off	OFF	Replacement mode active, but set to motor stop
No active influences	OK	No active influences active

Table 23: Active influences

Active influences on the hydraulic output – displayed in the home screen

Name	Displayed symbols	Description
Limitation of the hydraulic output		Limitation of hydraulic output due to external influences such as too high temperature or insufficient power supply.
No active influences	-	No active influences on the volume flow.

Table 24: Active influences

9.4.6 Submenu

Each submenu is made up of a list of submenu items. The title identifies a subsequent submenu or settings dialogue.

9.4.7 Main menu “Settings” – Menu overview

The following table gives an overview of the “Settings” main menu:

Universal	Display text
1.0	Settings
1.1	Control settings
1.1.1	Control mode
$\Delta p-v$	$\Delta p-v$
$\Delta p-c$	$\Delta p-c$
n-c	n-c
PID control	PID control
1.1.2 ¹	Setpoint ¹
1.1.2 $\Delta p-v$,	$\Delta p-v$
1.1.2 $\Delta p-c$,	$\Delta p-c$
1.1.2 n-c,	n-c
1.1.2 PID	PID control
1.1.2 $\Delta p-v$	Setpoint $\Delta p-v$
H set =	H target =
1.1.2 $\Delta p-c$	Setpoint $\Delta p-c$
H set =	H target =
1.1.2 n-c	Setpoint n-c
n act =	n is =
1.1.2 PID	Setpoint PID
Setpoint =	Setpoint =
1.1.3 Kp^2	Parameter Kp^2
1.1.4 Ti^2	Parameter Ti^2
1.1.5 Td^2	Parameter Td^2
1.1.6 ²	Control inversion ²
OFF	Inversion OFF
ON	Inversion ON

Universal	Display text
1.1.7	Emergency operation
OFF	Pump OFF
ON	Pump ON
1.1.8 ³	Emergency operation speed ³
1.1.9	Setpoint source
1.1.9/1	Internal setpoint
1.1.9/2	Analogue input (AI2)
1.1.9/3	CIF module
1.1.10 ⁴	Substitute setpoint ⁴
1.1.15	Pump ON/OFF
OFF	Switched off
ON	Switched on
1.3	External interfaces
1.4	Dual pump management
1.5	Display settings
1.6	Additional settings

¹ According to the currently set control mode, only the corresponding setpoint opens.

² The menu item only opens if the PID control mode is set.

³ The menu item only opens if emergency operation is set to “ON”.

⁴ The menu item only opens if analogue input AI2 is selected as the setpoint source.

9.4.8 Main menu “Settings”

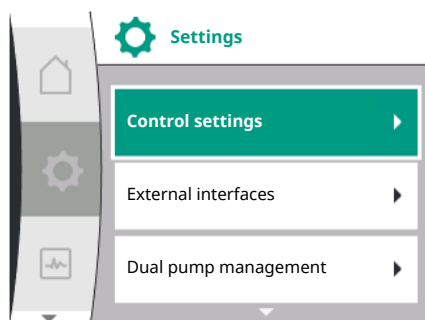

Fig. 39: Settings menu

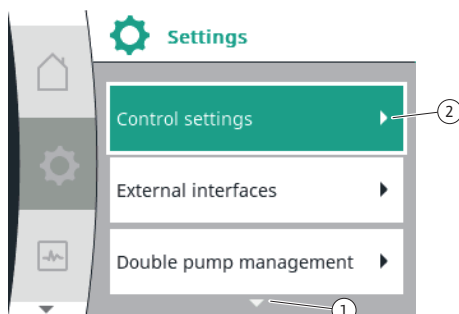



Fig. 40: Settings menu

Different settings can be changed in the “Settings” menu .

The “Settings” menu is selected by turning the operating button to the “gear wheel” symbol .



Confirm the selection by pressing the operating button. Selectable submenus open. Select a submenu by turning the operating button to the right or left. The selected submenu item is highlighted in colour.



Press the operating button to confirm the selection. The selected submenu or downstream settings dialogue appears.



NOTICE

If there are more than three submenu items, this is indicated by an arrow  above or below the visible menu items. Turn the operating button in the corresponding direction to open the submenu items on the display.

An arrow  above or below a menu area indicates that additional submenu items are available in this area. These submenu items are accessed by turning  the operating button.



An arrow  to the right in a submenu item indicates that another submenu is accessible. Pressing  the operating button opens this submenu.

If there is no arrow pointing to the right, a settings dialogue can be accessed by pressing the operating button.



NOTICE

Briefly press the Back button  in a submenu to return to the previous menu.

Briefly press the Back button  in the main menu to return to the Home screen. If there is an error, pressing the Back button  takes you to the error display (Section “Error messages” [► 98]).

If there is an error, holding down the Back button  (> 1 second) takes you back to the Home screen or to the error display from any settings dialogue and from any menu level.

9.4.9 Settings dialogues

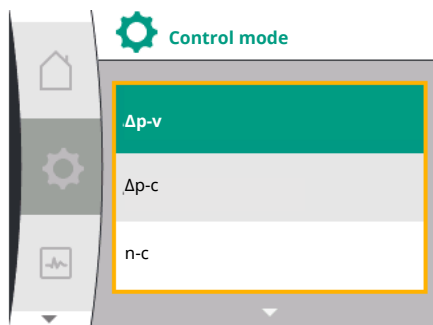

Fig. 41: Settings dialogue

Settings dialogues have been highlighted with a yellow frame and show the current setting. Turn the operating button to the right or left to adjust the highlighted setting. Press the operating button to confirm the new setting. The focus returns to the menu you opened.

If you do not turn the operating button before pressing, the previous setting remains unchanged.

One or more parameters can be set in the settings dialogues.

- If only one parameter can be set, the focus returns to the menu you opened after having confirmed the parameter value (pressing the operating button).
- If several parameters can be set, the focus changes to the next parameter after having confirmed a parameter value.

If you confirm the last parameter in the settings dialogue, the focus returns to the menu you opened.

Press the “Back” button  to return the focus to the previous parameter. The previously changed value will be discarded because it had not been confirmed.

Press the operating button to check set parameters and switch between them. In this process, existing parameters are once again confirmed, but not changed.



NOTICE

Press the operating button without selecting another parameter or adjusting another value to confirm the setting.

Press the Back button  to discard the current adjustment and retain the previous setting. The menu changes to the previous setting or previous menu.

9.4.10 Status area and status displays

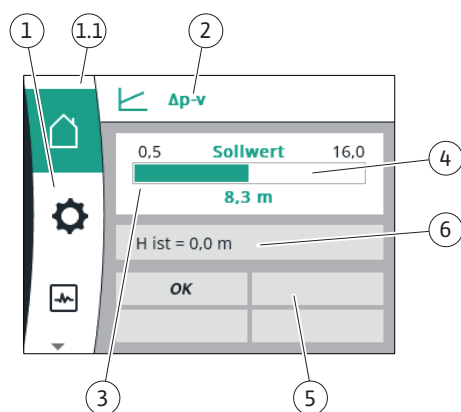

Fig. 42: Status area

The status area is located on the left side above the main menu area ^{1.1}. (See also table “Home screen” [► 57] in “Home screen” [► 56] section).

When a status is active, status menu items can be displayed and selected in the main menu. Turning the operating button to the status area shows the active status.

When an active process is finished or withdrawn, the status display closes.

There are three different classes of status displays:

1. Display process:
On-going processes have been highlighted in blue.
Processes mean pump operation may deviate from the adjusted control.
2. Display warning:
Warning messages have been highlighted in yellow.
The pump functions are restricted if a warning has been output (see “Warning messages” [► 100] section).
Example: Cable break detection on analogue input.
3. Display error:
Error messages have been highlighted in red.
The pump stops operation if an error has occurred. (see “Error messages” [► 98] section).
Example: blocking rotor.

Further status displays, if available, can be displayed by turning the operating button to the corresponding symbol.



Symbol	Meaning
	Error message Pump stopped!
	Warning message Pump operation restricted!
	Communication status – a CIF module has been installed and is active. Pump in control mode, monitoring and control by building automation available.

Table 25: Potential data displayed in the status area



NOTICE

A set control mode is interrupted when a process is running. The pump starts to run in the set control mode once the process is ended.



NOTICE

Repeatedly pressing or pressing and holding the Back button after an error message has occurred will open the “Error” status display and not take you back to the main menu.

The status area is highlighted in red.

10 Control settings

10.1 Control functions

The following control functions are available:

- Differential pressure $\Delta p-v$
- Differential pressure $\Delta p-c$
- Speed constant (n-const.)
- PID control

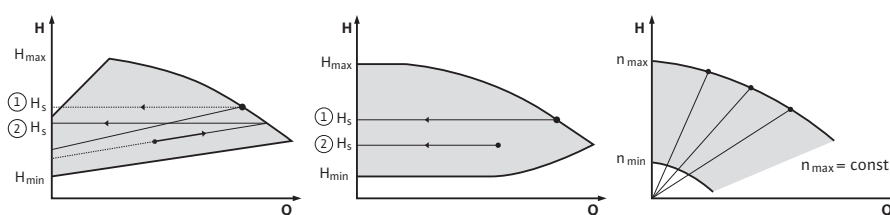

Fig. 43: Control functions

Differential pressure $\Delta p-v$ (factory setting for Yonos GIGA2.0)

The control changes the differential pressure setpoint to be maintained by the pump linearly between reduced differential pressure H and H_{target} . The controlled differential pressure H decreases or increases with the flow rate.

Differential pressure $\Delta p-c$

The control keeps the differential pressure generated by the pump constant over the permissible flow rate range at the set differential pressure setpoint H_{target} up to the maximum characteristic curve.

Starting from a required delivery head to be set according to the design point, the pump variably adapts the pump capacity to the required volume flow. The volume flow varies due to the open and closed valves on the consumer circuits. The pump output is adjusted to the requirements of the consumer load and the energy requirement is reduced.

Constant speed (n-c / factory setting for Yonos GIGA2.0 ... R1)

The speed of the pump is kept at a set constant speed. The speed range is dependent on the motor and pump type.

User-defined PID control

The pump controls based on a user-defined control function. The PID control parameters K_p , T_i and T_d must be specified manually.

The PID controller used in the pump is a standard PID controller.

The controller compares the measured actual value with the specified setpoint and attempts to match the actual value to the setpoint as closely as possible.

Provided the appropriate sensors are used, various controls can be implemented.

When selecting a sensor, attention must be paid to the configuration of the analogue input. The control behaviour can be optimised by changing the P, I and D parameters.

The direction of control action can be adjusted by switching the control inversion on or off.

10.2 Selecting a control mode

The following submenus can be selected in the “Settings” menu (Universal 1.0):

Universal	Display text
1.1	Control settings
1.3	External interfaces
1.4	Dual pump management
1.5	Display settings

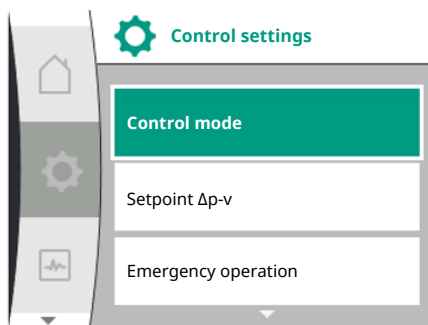

Fig. 44: Control mode

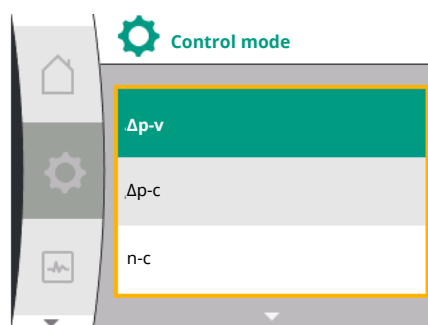

Fig. 45: Control mode selection

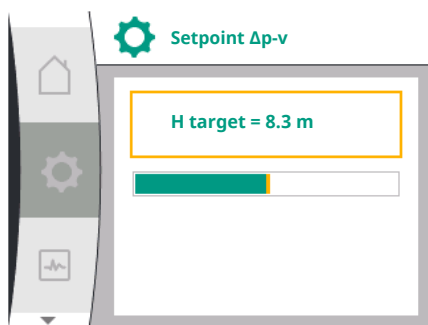

Fig. 46: Setting setpoint Δp-v

Universal	Display text
1.6	Additional settings

To choose a control mode, select the following in succession:

Universal	Display text
1.0	Settings
1.1	Control settings
1.1.1	Control mode

The following basic control modes are available to select from:

Universal	Display text
Δp-v	Δp-v
Δp-c	Δp-c
n-c	n-c
PID control	PID control

The Δp-c and Δp-v control modes require a differential pressure sensor to be connected to the analogue input AI1.



NOTICE

With Yonos GIGA2.0, the control mode Δp-v and the differential pressure sensor are preconfigured to the analogue input AI1 as a factory setting. With Yonos GIGA2.0 ... R1, the control mode n-c and no analogue input is preconfigured.

After selecting the desired control mode, the “Control setting” menu opens again. Additional settings can be changed.



NOTICE

Each control mode is configured with a default parameter as a factory setting. When changing the control mode, previously set configurations such as external sensors or operating status are not carried over. All parameters must be set again.

Specific parameters for differential pressure Δp-v

If the Δp-v control mode is selected, the submenu “Setpoint Δp-v” opens in the “Control setting” menu. The desired delivery head can be set as the setpoint.

Universal	Display text
1.1.2 Δp-v	Setpoint Δp-v
H set =	H target =

After confirming the setpoint, the “Control setting” menu opens again.

Specific parameters for differential pressure Δp-c

If the Δp-c control mode is selected, the “Setpoint Δp-c” submenu opens in the “Control setting” menu. The desired delivery head can be set as the setpoint. After confirming the setpoint, the “Control setting” menu opens again.

Specific parameters for constant speed (n-c)

If the control mode constant speed n-c is selected, the submenu “Setpoint n-c” opens in the “Control setting” menu. The desired speed can be set as the setpoint. After confirming the setpoint, the “Control setting” menu opens again.

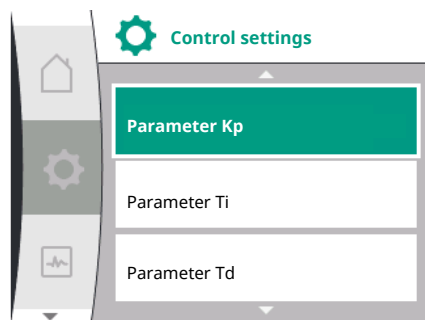

Fig. 47: Setting PID parameters

PID specific parameters

If the control mode “PID control” is selected, the submenus “Setpoint PID”, Parameter Kp, Parameter Ti, Parameter Td and control inversion open in the “Control setting” menu. The desired percentage value can be set as the setpoint in the “PID setpoint” menu. In the Kp, Ti and Td parameter submenus, the parameters can be set as the setpoint according to the desired behaviour. The control inversion can be switched off and on. After setting the desired values, the “Control setting” menu opens again.

Universal	Display text
1.0	Settings
1.1	Control settings
1.1.1	Control mode
1.1.2 PID	Setpoint PID
Setpoint =	Setpoint =
1.1.3 Kp ²	Parameter Kp ²
1.1.4 Ti ²	Parameter Ti ²
1.1.5 Td ²	Parameter Td ²
1.1.6 ²	Control inversion ²
OFF	Inversion OFF
ON	Inversion ON

² The menu item only opens if control mode PID is set.

10.3 Setting the setpoint source



NOTICE

The setpoint can only be adjusted if the setpoint source is set to “Internal setpoint”.

If “Internal setpoint” has not been selected in the “Setpoint source” menu, the green adjustment bar in the “Setpoint” menu is not active. No setting can be changed.

To set the setpoint source, select the following in succession:

Universal	Display text
1.0	Settings
1.1	Control settings
1.1.9	Setpoint source

The following setpoint sources are available to select from:

Universal	Display text
1.1.9 / 1	Internal setpoint
1.1.9 / 2	Analogue input (AI2)
1.1.9 / 3	CIF module

The setpoint source “Internal setpoint” can be set in the display. The setpoint sources “Analogue input AI2” and “CIF module” expect a setpoint from an external source.



NOTICE

A CIF module can only be selected as a setpoint source if a CIF module is installed. The menu item cannot otherwise be selected.

If the setpoint is set via the analogue input AI2, the analogue input can be configured in the “Settings” menu.

If an external setpoint source (analogue input AI2 or CIF module) is selected, the menu item “Substitute setpoint” opens. A fixed setpoint can be specified here, which is used for control in the event of a malfunction of the setpoint source (such as a cable break at the analogue input or no communication to the CIF module).

After confirming the selected setpoint source, the “Control setting” menu opens again.

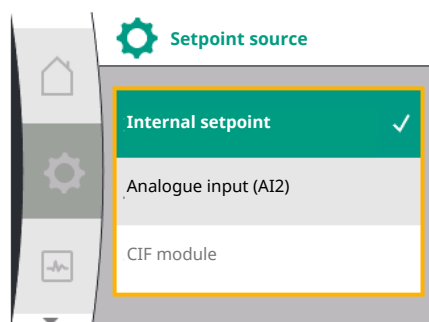

Fig. 48: Setting the setpoint source

10.4 Emergency operation

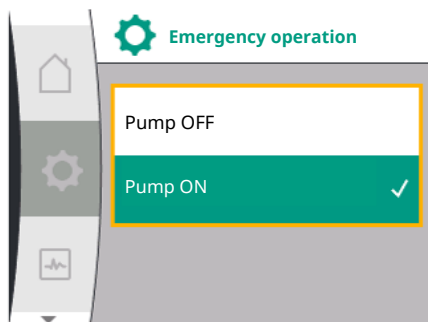

Fig. 49: Setting emergency operation

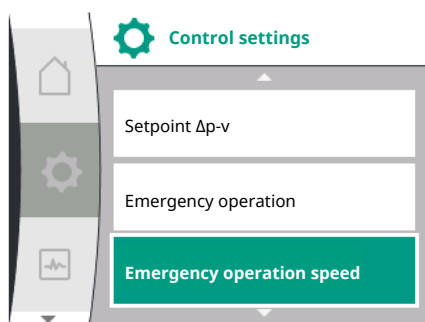

Fig. 50: Setting the emergency operation speed

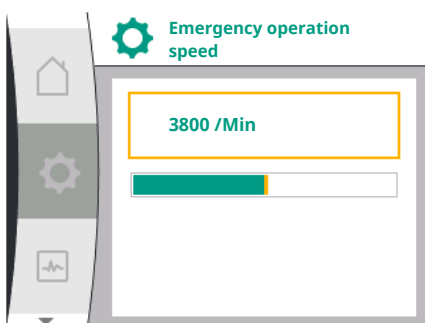

Fig. 51: Emergency operation speed

10.5 Switch off motor

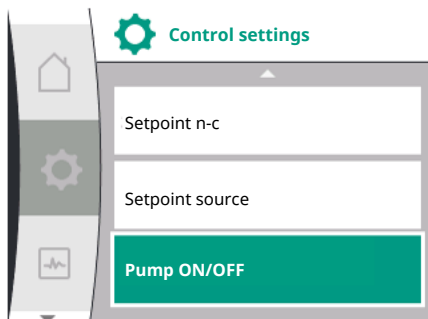

Fig. 52: Control setting pump ON/OFF

In the event of a malfunction (such as failure of the required sensor) an “emergency operation” can be defined. (Only adjustable for control modes $\Delta p-v$ and $\Delta p-c$)

In the “Emergency operation” menu, you can choose between “Pump OFF” and “Pump ON”. To do this, select the following in succession:

Universal	Display text
1.0	Settings
1.1	Control settings
1.1.7	Emergency operation
OFF	Pump OFF
ON	Pump ON

If “Pump ON” is selected, the corresponding speed can be set in the “Emergency operation speed” submenu:

Universal	Display text
1.0	Settings
1.1	Control settings
1.1.8 ³	Emergency operation speed ³

³ Menu item opens only when emergency operation is set to “ON”.

After confirming the emergency operation speed setpoint, the “Control setting” menu opens again.

The motor of the pump can be switched on and off in the “Settings” menu . To do this, select the following in succession:

Universal	Display text
1.0	Settings
1.1	Control settings
1.1.15	Pump ON/OFF
OFF	Switched off
ON	Switched on

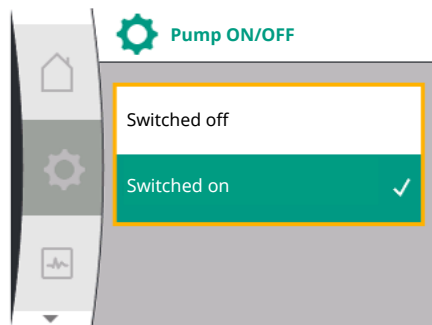

Fig. 53: Switching the pump on or off

10.6 Configuration storage/data storage

It is possible to switch off the pump via the manual function "Pump On/Off". The motor is stopped and the control mode with the set control function is interrupted. In order for the pump to continue running in the set control mode, it must be actively switched on again via "Pump On".



DANGER

Risk of fatal electrical shock!

The "Pump OFF" connection only overrides the set control function and only stops the motor. This means that the pumps are not voltage-free.

- Always disconnect the pump from the power supply for maintenance work!

11 Double pump operation

11.1 Dual pump management

The electronic module is equipped with a non-fading memory for saving the configuration. If the mains supply is interrupted for any length of time, all settings and data are retained. When power is restored, the pump continues to run with the default values that were present before the interruption.

All Yonos GIGA2.0 pumps are equipped with integrated dual pump management.

A twin-head pump connection can be established or disconnected in the "Dual pump management" menu. The twin-head pump function can also be set here.

The dual pump management has the following functions:

- **Main/standby operation:**
Each of the two pumps provides the configured flow rate. The other pump is available in case of malfunction or runs after pump cycling.
Only one pump runs at a time (factory setting).
The main/standby operation is also completely active even for two similar single pumps in a twin-head pump installation in the Y-piece.
- **Efficiency-optimised peak-load operation (parallel operation):**
In peak-load operation (parallel operation), the hydraulic output is provided jointly by both pumps.
In the partial load range, the hydraulic output is initially provided by just one of the two pumps.
If the sum of the electrical power consumption P1 of both pumps in the partial load range is less than the power consumption P1 of one pump, then the second pump is switched on with optimised efficiency.
This operating mode optimises operational efficiency compared to conventional peak-load operation (exclusively load-sensitive switching on and off).
If only one pump is available, the remaining pump takes over the supply. The possible peak load is limited due to the power of the single pump. Parallel operation is also possible with two single pumps of the same type in twin-head pump operation in the Y-piece.
- **Pump cycling:**
The actively operated pump is regularly changed automatically to guarantee even usage of both pumps in the event of single pump operation. If only one pump (main/standby, peak load or night setback) is running, the pump being operated is changed after a running time of 24 h at the latest. Both pumps run at the time of pump changeover so that operation is not interrupted. The operated pump can be replaced at least every 1 hour and can be set in length increments up to a maximum of 36 hours.



NOTICE

Even after switching the mains voltage off and on again, the remaining time until the next pump cycling continues to run. The timer does not start again from the beginning!

- **SSM/ESM (collective fault signal/individual fault signal):**
 - The **SSM function** must preferably be connected to the main pump. The SSM contact can be configured as follows:
the contact reacts either only in the event of a fault or in the event of a fault and a warning.
Factory setting SSM only reacts in the event of a fault.

Alternatively or additionally, the SSM function can also be activated on the standby pump. Both contacts work in parallel.

- **ESM:** The ESM function of the twin-head pump can be configured on each head of the twin-head pump head as follows: The ESM function on the SSM contact only signals faults of the respective pump (individual fault signal). In order to record all faults of the two pumps, both contacts must be assigned.
- **SBM/EBM (collective run signal/individual run signal):**
 - The **SBM contact** can be assigned to any of the two pumps. The following configuration is possible:
The contact is activated when the motor is in operation, power supply is present or no fault is present.
Factory setting: ready for operation. Both contacts signal the operating status of the twin-head pump in parallel (collective run signal).
 - **EBM:** The EBM function of the twin-head pump can be configured as follows:
The SBM contacts only signal run signals of the respective pump (individual run signal). In order to record run signals of both the pumps, both contacts must be assigned.
- **Communication between pumps:**
Communication for a twin-head pump has been set at the factory.
Wilo Net must be installed with cable between the pumps when connecting two single pumps of the same type to a twin-head pump.
Then set the termination as well as the Wilo Net address in the menu under “Settings/external interfaces/Wilo Net setting”. Then, in the “Dual pump management” submenu of the “Settings” menu, select the settings “Connect twin-head pump”.



NOTICE

For the installation of two single pumps to form a twin-head pump, see sections “Twin-head pump installation/Y-pipe installation” [► 39], “Electrical connection” [► 40] and “Application and function of the Wilo Net interface” [► 85].

11.2 Twin-head pump behaviour

The control of both pumps starts from the main pump to which the differential pressure sensor is connected.

In case of **breakdown/fault/communication interruption**, the main pump alone takes over complete operation. The main pump runs as a single pump according to the set operating modes of the twin-head pump.

The standby pump, which receives no data from the differential pressure sensor in the control modes ($\Delta p-v$, $\Delta p-c$), runs in the following cases at an adjustable constant emergency operation speed:

- The main pump to which the differential pressure sensor is connected fails.
- The communication between the main pump and the standby pump is interrupted.

The standby pump starts immediately after detecting a fault.

With the n-const. control mode, there is no adjustable emergency operation. In this case, the standby pump runs at the last known speed both in main/standby operation and in parallel operation.

11.3 Settings menu – dual pump management

In the “Dual Pump Management” menu, a twin-head pump connection can be established or disconnected and you can also set the twin-head pump function.

The  settings menu “Dual Pump Management” has different submenus depending on the status of the twin-head pump connection.

The following table gives an overview of possible settings in the dual pump management:

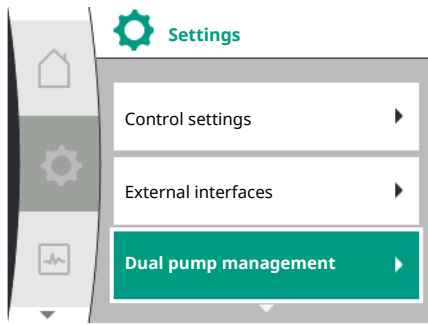

Fig. 54: Dual pump management menu

Universal	Display text
1.0	Settings
1.4	Dual pump management
1.4.1	Connecting twin-head pump
1.4.1.1	Twin-head pump partner address
1.4.1.2	Establish twin-head pump connection
Confirm (Pump will reset!)	Confirm (pump will reset!)
Double pump pairing status	Twin-head pump pairing status
Pairing in progress...	Pairing in progress...
Pairing successful.	Pairing successful
Pairing failed.	Pairing failed
Reset will follow.	Reset will follow
Partner not found.	Partner not found
Partner already paired.	Partner already paired
Partner incompatible.	Partner incompatible
Partner Node-ID:	Partner node ID:
Cancel	Cancel
1.4.2	Disconnecting twin-head pump
Confirm (Pump might re-set!)	Confirm (Pump might reset!)
1.4.3	Twin-head pump function
1.4.3.1	Main/reserve
1.4.3.2	Peak-load operation
1.4.4	Pump cycling
1.4.4.1	Time-based pump cycling: ON/OFF
1.4.4.2	Time-based pump cycling: Interval
1.4.4.3	Manual pump cycling
Confirm	Confirm
Cancel	Cancel
1.4.5	Pump housing type
1.4.5 / 1	Single pump
1.4.5 / 2	Twin-head pump (left):
1.4.5 / 3	Twin-head pump (right):

The following settings are possible with **no** existing twin-head pump connection:

- Twin-head pump connection.
- Pump housing type

The following settings are possible with an existing twin-head pump connection:

- Disconnect twin-head pump.
- Twin-head pump function
- Set pump cycling.
- Pump housing type



NOTICE

With a factory-supplied twin-head pump, the twin-head pump connection is pre-configured and active.

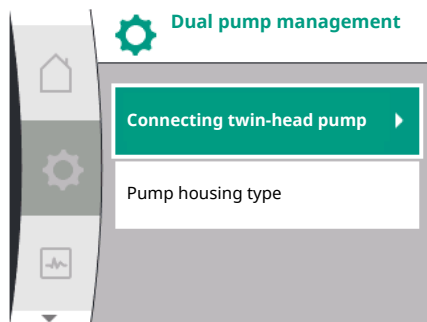

Fig. 55: Dual pump management menu

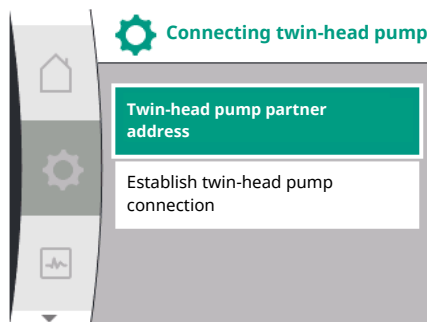



Fig. 56: Connect twin-head pump menu

Menu “Connecting twin-head pump”

If a twin-head pump connection has not yet been established, select the following in the “Settings” menu :

Universal	Display text
1.0	Settings
1.4	Dual pump management
1.4.1	Connecting twin-head pump

The Wilo Net address of the twin-head pump partner must first be set for both pumps of the twin-head pump.

Example:

Pump I is assigned the Wilo Net address 1, pump II the Wilo Net address 2. The address 2 of the twin-head pump partner must then be set in pump I and address 1 in pump II.

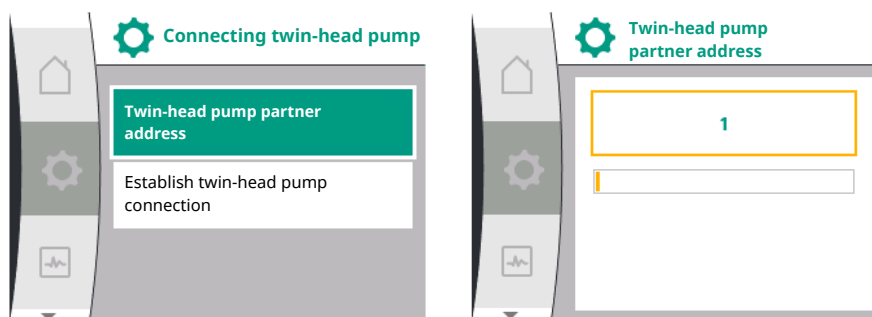

NOTICE

For notes on the Wilo Net address, see sections “Application and function of the Wilo Net interface” [▶ 85] and “Connection of Wilo Net for twin-head pump function” [▶ 49].

When the configuration of the partner addresses is complete, the twin-head pump connection can be started or cancelled.

Universal	Display text
1.4.1	Connecting twin-head pump
1.4.1.1	Twin-head pump partner address
1.4.1.2	Establish twin-head pump connection



NOTICE

The pump from which the twin-head pump connection is started is the main pump. Always select the pump to which the differential pressure sensor is connected as the main pump.

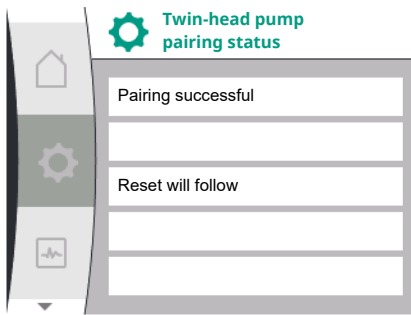

Fig. 57: Successful twin-head pump connection

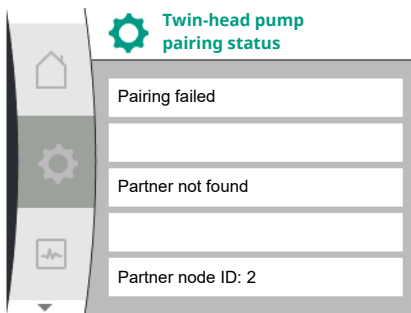

Fig. 58: Failed dual connection

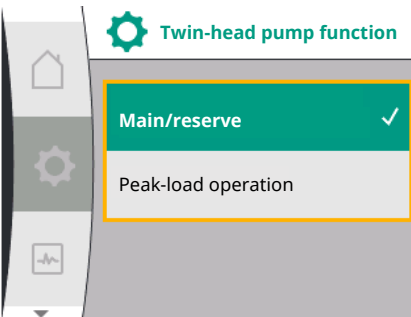

Fig. 59: Twin-head pump function menu

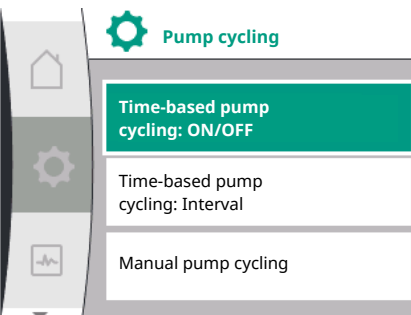

Fig. 60: Pump cycling menu

Successful twin-head pump connection:

Universal	Display text
Double pump pairing status	Twin-head pump pairing status
Pairing successful.	Pairing successful
Reset will follow.	Reset will follow



NOTICE

Activating the twin-head pump connection fundamentally changes various parameters of the pump. The pump is then started automatically.

Failed twin-head pump connection:

Universal	Display text
Double pump pairing status	Twin-head pump pairing status
Pairing failed.	Pairing failed
Partner not found.	Partner not found
Partner Node-ID:	Partner node ID:



NOTICE

If there is an error in the twin-head pump connection, the partner address must be reconfigured! Always check the partner addresses beforehand!

Menu "Twin-head pump function"

When a twin-head pump connection is established, you can switch between the following functions in the "Twin-head pump function" menu:

- **Main/standby operation** and
- **Efficiency-optimised peak-load operation (parallel operation)**

Universal	Display text
1.4.3	Twin-head pump function
1.4.3.1	Main/reserve
1.4.3.2	Peak-load operation



NOTICE

When switching the twin-head pump function, different parameters of the pump are fundamentally changed. The pump is then automatically restarted. The main menu then opens again.

"Pump cycling" menu

If a twin-head pump connection has been established, the function can be switched on and off and the time interval of the pump cycling can be set in the "Pump cycling" menu. Time interval: between 1 h and 36 h, factory setting: 24 h.

Universal	Display text
1.4.4	Pump cycling
1.4.4.1	Time-based pump cycling: ON/OFF
1.4.4.2	Time-based pump cycling: Interval
1.4.4.3	Manual pump cycling
Confirm	Confirm

Universal	Display text
Cancel	Cancel

An immediate pump cycling can be triggered via the menu item “manual pump cycling”. Manual pump cycling can always be carried out regardless of the configuration of the time-based pump cycling function.

Menu “Disconnect twin-head pump”

When a twin-head pump function is established, it can also be separated. To do this, select the following:

Universal	Display text
1.0	Settings
1.4	Dual pump management
1.4.2	Disconnecting twin-head pump
Confirm (Pump might re-set!)	Confirm (Pump might reset!)



NOTICE

Disconnecting the twin-head pump function fundamentally changes various parameters of the pump. The pump is then started automatically.

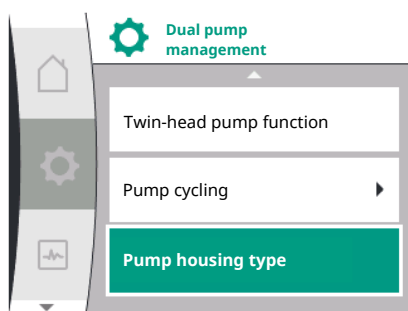

Fig. 61: Dual pump management menu

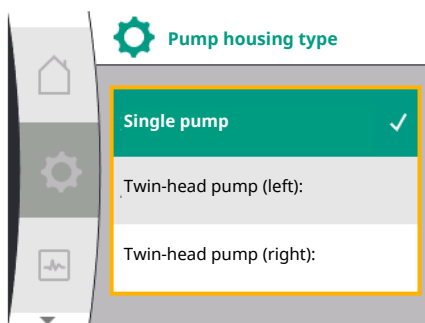

Fig. 62: Pump housing type menu

“Pump housing type” menu

The selection at which hydraulic position a motor head is mounted is made independently of a twin-head pump connection.

The following selection is available in the “Pump housing type” menu:

- Single pump hydraulics
- Twin-head pump hydraulics I (left in flow direction)
- Twin-head pump hydraulics II (right in flow direction)

Universal	Display text
1.0	Settings
1.4	Dual pump management
1.4.5	Pump housing type
1.4.5 / 1	Single pump
1.4.5 / 2	Twin-head pump (left):
1.4.5 / 3	Twin-head pump (right):



NOTICE

The configuration of the hydraulics must be carried out before establishing the twin-head pump connection. With twin-head pumps delivered from the factory, the hydraulic position is pre-configured.

11.4 Display for twin-head pump operation

Each twin-head pump partner has its own graphic display, showing the values and settings. The home screen can be seen on the display of the main pump with a mounted differential pressure sensor, as with a single pump.

The feature SL is shown on the display of the partner pump without a mounted differential pressure sensor in the setpoint display field.



NOTICE

If a twin-head pump connection is established, entries on the graphic display of the pump partner are not possible. This can be identified by a lock symbol on the “Main menu symbol”.

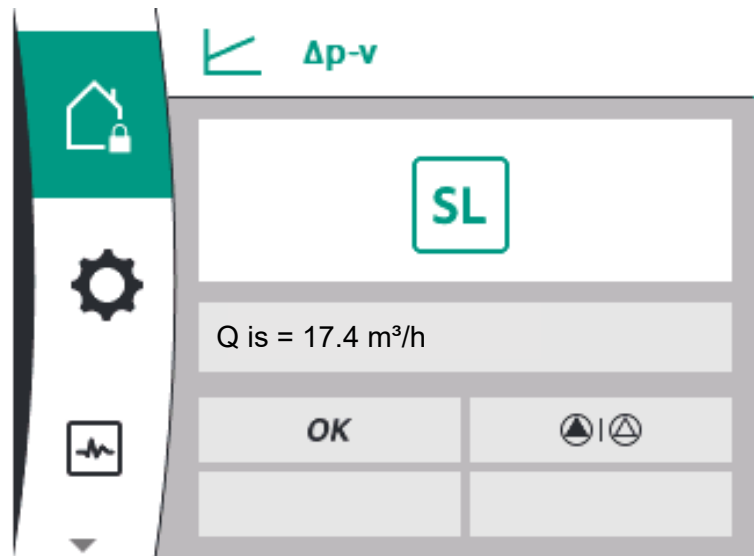

Fig. 63: Twin-head pump partner home screen

Symbol of main and partner pump

The home screen shows which pump is the main pump and which is the partner pump.

- Main pump with a mounted differential pressure sensor: “Home screen” as with single pump
- Partner pump without a mounted differential pressure sensor: symbol SL in setpoint display field

Two pump symbols are displayed in twin-head pump operation in the “Active influences” area. This is what they mean:

Case 1 – main/standby operation: only the main pump is running.

Indication on the display of the main pump



Indication on the display of the partner pump



Case 2 – main/standby operation: only the partner pump is running.

Indication on the display of the main pump



Indication on the display of the partner pump



Case 3 – parallel operation: only the main pump is running.

Indication on the display of the main pump



Indication on the display of the partner pump



Case 4 – parallel operation: only the partner pump is running.

Indication on the display of the main pump



Indication on the display of the partner pump



Case 5 – parallel operation: only the main pump and partner pump are running.

Indication on the display of the main pump



Indication on the display of the partner pump



Case 6 – Main/standby or parallel operation: No pump running.

Indication on the display of the main pump



Indication on the display of the partner pump



Active influences of the pump status on the display in the home screen for twin-head pumps

The active influences are listed from highest to lowest priority.

The symbols shown for the two pumps in twin-head pump mode mean:

- The left symbol represents the pump being viewed.
- The right-hand symbol represents the partner pump.



















Name	Displayed symbols	Description
Main/standby operation: Error on partner pump OFF	 	Twin-head pump is set in main/standby operation. This pump head is inactive due to: <ul style="list-style-type: none"> • Control mode • Error at the pump partner.
Main/standby operation: Error at the partner pump	 	Twin-head pump is set in main/standby operation. This pump head is active due to a fault at the pump partner.
Main/standby operation: OFF	 	Twin-head pump is set in main/standby operation. Both pumps are inactive in control mode.
Main/standby operation: This pump head is active	 	Twin-head pump is set in main/standby operation. This pump head is active in control mode.
Main/standby operation: Partner pump active	 	Twin-head pump is set in main/standby operation. The pump partner is active in control mode.
Parallel operation: OFF	 + 	Twin-head pump is set in parallel operation. Both pumps are inactive in control mode.
Parallel operation: Parallel operation	 + 	Twin-head pump is set in parallel operation. Both pumps are active in parallel in control mode.
Parallel operation: This pump head active	 + 	Twin-head pump is set in parallel operation. This pump head is active in control mode. The pump partner is inactive .
Parallel operation: Pump partner active	 + 	Twin-head pump is set in parallel operation. The pump partner is active in control mode. This pump head is inactive . In the event of an error at the pump partner, this pump head will run.

Table 26: Active influences

12 Communication interfaces: Setting and function

Select the following in the “Settings” menu :

Universal	Display text
1.0	Settings
1.3	External interfaces

Possible selection of external interfaces:

Universal	Display text
1.3.1	SSM relay
1.3.2	Control input

Universal	Display text
1.3.3	Analogue input (AI1)
1.3.4	Analogue input (AI2)
1.3.5	Wilco Net settings
1.3.6	SBM relay



NOTICE

The submenus for setting the analogue inputs are only available depending on the selected control mode.

12.1 Menu overview of “External interfaces”

Universal	Display text
1.0	Settings
1.3	External interfaces
1.3.1	SSM relay
1.3.2	Binary input
1.3.3	Analogue input (AI1)
1.3.4	Analogue input (AI2)
1.3.5	Wilco Net settings
1.3.6	SBM relay

12.2 SSM application and function

The contact of the collective fault signal (SSM, potential-free changeover contact) can be connected to a building automation system. The SSM relay can either switch on only in case of fault or for faults and warnings. The SSM relay can be used as a normally closed contact or a normally open contact.

- When the pump is without power, the NC contact is closed.
- If there is a fault, the contact at NC is open. The converter bridge to NO is closed.

To do this, select the following in the menu:

Universal	Display text
1.0	Settings
1.3	External interfaces
1.3.1	SSM relay
1.3.1.2	SSM relay function ¹
1.3.1.2 / 1	Error present
1.3.1.2 / 2	Error or warning present
1.3.1.2 / 3	Error present at twin-head pump head

¹Only appears if twin-head pump is configured.

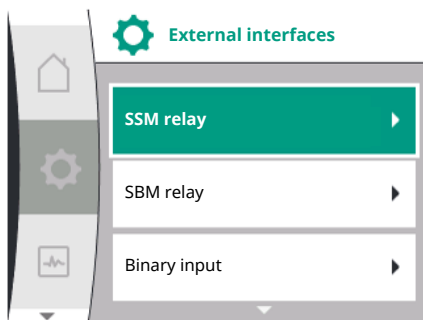

Fig. 64: External interfaces menu

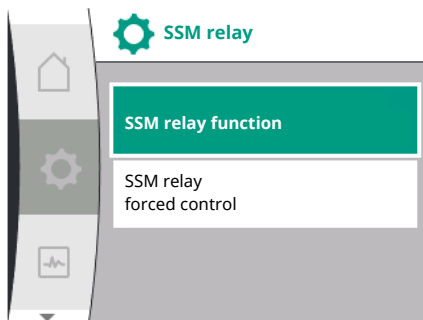

Fig. 65: Menu SSM-relay

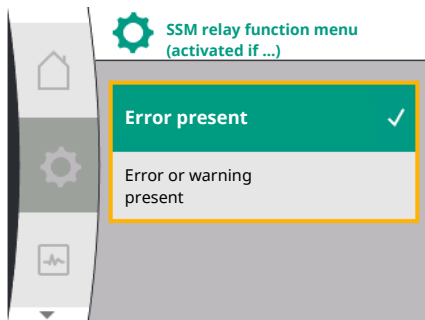

Fig. 66: SSM relay function menu

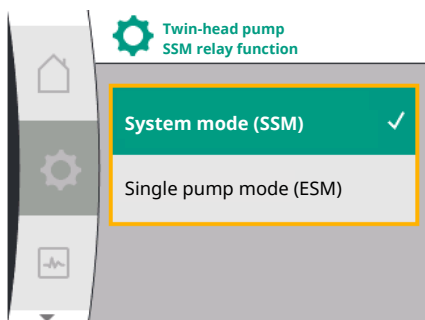

Fig. 67: Twin-head pump SSM relay function menu

12.3 SSM relay forced control

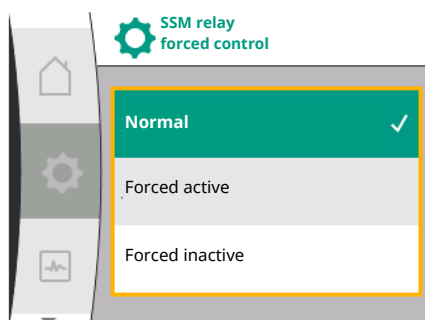

Fig. 68: SSM relay forced control

Possible settings:

Selection option	Function SSM relay
Only fault (factory setting)	SSM relay connects only in case of fault. Fault means: The pump is not running.
Faults and warnings	SSM relay connects only in case of fault or a warning.

Table 27: Function SSM relay

SSM/ESM (collective fault signal/individual fault signal) in twin-head pump operation

- SSM:** The SSM function must preferably be connected to the main pump. The SSM contact can be configured as follows: the contact reacts either only in the event of a fault or in the event of a fault and a warning. Factory setting: SSM only reacts in the event of a fault. Alternatively or additionally, the SSM function can also be activated on the standby pump. Both contacts work in parallel.
- ESM:** The ESM function of the twin-head pump can be configured on each twin-head pump head as follows: The ESM function on the SSM contact only signals faults of the respective pump (individual fault signal). In order to detect all faults of the two pumps, the contacts must be assigned in both drives.

Universal	Display text
1.0	Settings
1.3	External interfaces
1.3.1	SSM relay
1.3.1.4 ²	Twin-head pump SSM relay function²
SSM	System mode (SSM)
ESM	Single pump mode (ESM)

² These sub-menus only appear when the twin-head pump is connected.

An SSM/SBM relay forced control is used as function test of the SSM relay and electrical connections.

To do this, select the following in the menu:

Universal	Display text
1.0	Settings
1.3	External interfaces
1.3.1	SSM relay
1.3.1.6	SSM relay forced control
1.3.1.6 / 1	Normal
1.3.1.6 / 2	Forced active
1.3.1.6 / 3	Forced inactive

Selection options:

SSM relay Forced control	Help text
Normal	SSM: Depending on the SSM configuration, fault and warnings influence the SSM relay switching status.
Forced active	SSM relay switching status is forced ACTIVE. CAUTION: SSM does not display the pump status!

SSM relay	Help text
Forced control	
Forced inactive	SSM/SBM relay switching status is forced INACTIVE. CAUTION: SSM does not display the pump status!

Table 28: Selection option SSM relay forced control

The “Forced active” setting permanently activates the relay. This means that, for example, a warning note (light) is permanently displayed/announced. The “Forced inactive” setting leaves the relay permanently without a signal. No warning note can be confirmed.

12.4 SBM application and function

The contact of the collective run signal (SBM, potential-free changeover contact) can be connected to a building automation system. The SBM contact signals the operating status of the pump.

- The SBM contact can be assigned to any of the two pumps. The following configuration is possible:
The contact is activated when the motor is in operation, power supply is present (network-ready) or no fault is present (ready for operation).
Factory setting: ready for operation. Both contacts signal the operating status of the twin-head pump in parallel (collective run signal).
Depending on the configuration, the contact is set to NO or NC.

To do this, select the following in the menu:

Universal	Display text
1.0	Settings
1.3	External interfaces
1.3.6	SBM relay
1.3.6.3	SBM relay function ¹
1.3.6.3 / 1	Motor running
1.3.6.3 / 2	Mains voltage present
1.3.6.3 / 3	Ready for operation

¹Only appears if twin-head pump is configured.

Possible settings:

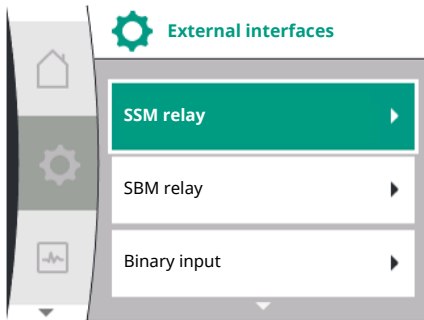

Fig. 69: External interfaces menu

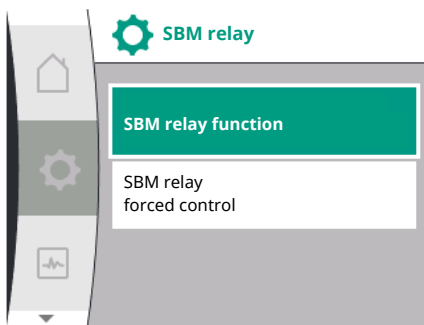

Fig. 70: Menu SBM-relay

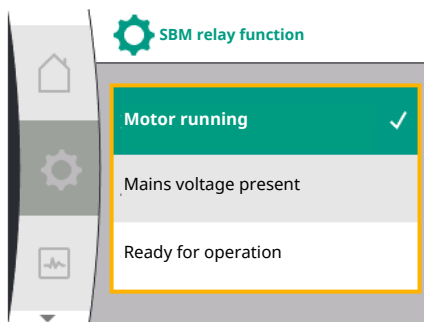

Fig. 71: SBM relay function menu

Selection option	Function SBM relay
Motor running (factory setting)	SBM relay connects when motor is running. Closed relay: The pump is supplying.
Mains voltage present	SBM relay connects for power supply. Closed relay: Voltage available.
Ready for operation	SBM relay connects when there is no fault. Closed relay: Pump can supply.

Table 29: Function SBM relay

SBM/EBM (collective run signal/individual run signal) in twin-head pump operation

- SBM:** The SBM contact can be assigned to any of the two pumps. Both contacts signal the operating status of the twin-head pump in parallel (collective run signal).

- **EBM:** The SBM function of the twin-head pump can be configured so that the SBM contacts signal only operational messages of the respective pump (individual run signal). In order to record run signals of both the pumps, both contacts must be assigned.

Universal	Display text
1.0	Settings
1.3	External interfaces
1.3.6	SBM relay
1.3.6.5 ²	Twin-head pump SBM relay function²
SBM	System mode (SBM)
EBM	Single pump mode (EBM)

² These sub-menus only appear when the twin-head pump is connected.

12.5 SBM relay forced control

An SBM relay forced control is used as function test of the SBM relay and electrical connections.

To do this, select the following in the menu:

Universal	Display text
1.0	Settings
1.3	External interfaces
1.3.6	SBM relay
1.3.6.7	SBM relay forced control
1.3.6.7 / 1	Normal
1.3.6.7 / 2	Forced active
1.3.6.7 / 3	Forced inactive

Selection options:

SBM relay Forced control	Help text
Normal	SBM: Depending on the SBM configuration, the pump status influences the SBM relay switching status.
Forced active	SBM relay switching status is forced ACTIVE. CAUTION: SBM does not display the pump status!
Forced inactive	SSM/SBM relay switching status is forced INACTIVE. CAUTION: SBM does not display the pump status!

Table 30: Selection option SBM relay forced control

The "Forced active" setting permanently activates the relay. This means that, for example, an operating note (light) is permanently displayed/announced.

The "Forced inactive" setting leaves the relay permanently without a signal. No operating note can be confirmed.

12.6 Application and function of the digital control input DI1

The pump can be switched on or off via external potential-free contacts at the digital input.

The following table provides an overview of the "Control input" menu:

Universal	Display text
1.0	Settings
1.3	External interfaces
1.3.2	Control input
1.3.2.1	Control input function
1.3.2.1 / 1	Not used
1.3.2.1 / 2	External OFF
1.3.2.2 ¹	Twin-head Pump ext. OFF function ¹

Universal	Display text
1.3.2.2 / 1	System mode
1.3.2.2 / 2	Single mode
1.3.2.2 / 3	Combined mode

¹ The submenu only opens when the twin-head pump is connected

Possible settings:

Selection option	Digital input function
Not used	The control input does not have a function.
External OFF	Contact open: Pump is switched off. Factory setting: Contact closed: Pump is switched on.

Table 31: Control input function DI1

Procedure with EXT. OFF for twin-head pumps

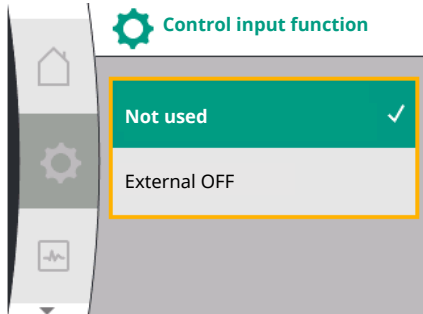

Fig. 72: Digital input menu function

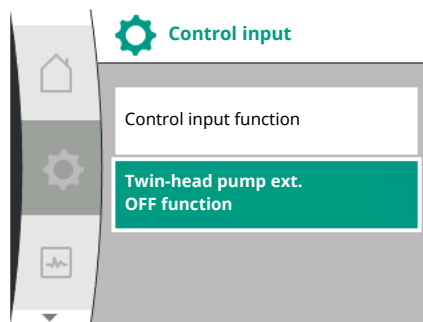

Fig. 73: Digital input menu

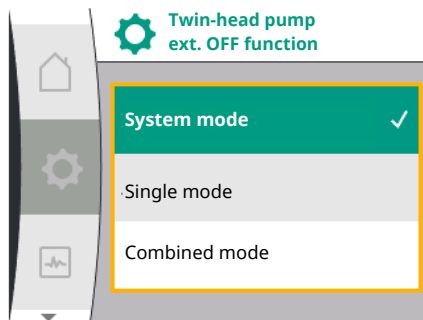

Fig. 74: Selectable modes for ext. OFF with twin-head pump

The function EXT. OFF always behaves as follows:

- EXT. OFF active: contact is open, pump is stopped (OFF).
- EXT. OFF inactive: contact is closed, pump runs in normal operation (ON).

The twin-head pump consists of two partners:

- Main pump: Twin-head pump partner **with** connected differential pressure sensor
- Partner pump: Twin-head pump partner **without** connected differential pressure sensor

The configuration of the control inputs has three possible modes for EXT. OFF which can influence the behaviour of the two twin-head pump partners.

The possible behaviours are described in the following tables.

System mode

The control input DI1 is equipped in the factory with a converter bridge and the function "EXT. OFF" is active.

The control input on the **main pump switches both twin-head pump partners.**

The **control input of the partner pump** is ignored and **has no meaning** regardless of its configuration. If the main pump fails or the twin-head pump connection is disconnected, the partner pump is also stopped.

States	Main pump			Partner pump		
	EXT. OFF	Behaviour of the pump motor	Display text for active influences	EXT. OFF	Behaviour of the pump motor	Display text for active influences
1	Active	Off	OFF Override OFF (DI1)	Active	Off	OFF Override OFF (DI1)
2	Not active	On	OK; normal operation	Active	On	OK; normal operation
3	Active	Off	OFF Override OFF (DI1)	Not active	Off	OFF Override OFF (DI1)
4	Not active	On	OK; normal operation	Not active	On	OK; normal operation

Table 32: System mode

Single mode

The control input DI1 is equipped in the factory with a converter bridge and the function "EXT. OFF" is active. **Each of the two pumps is individually switched by its own control input.** If the main pump fails or the twin-head pump connection is disconnected, the control input of the partner pump is evaluated.

States	Main pump			Partner pump		
	EXT. OFF	Behaviour of the pump motor	Display text for active influences	EXT. OFF	Behaviour of the pump motor	Display text for active influences
1	Active	Off	OFF Override OFF (DI1)	Active	Off	OFF Override OFF (DI1/2)
2	Not active	On	OK; normal operation	Active	Off	OFF Override OFF (DI1/2)
3	Active	Off	OFF Override OFF (DI1)	Not active	On	OK; normal operation
4	Not active	On	OK; normal operation	Not active	On	OK; normal operation

Table 33: Single mode

Combined mode

The control input DI1 is equipped in the factory with a converter bridge and the function "EXT. OFF" is active. **The control input of the main pump switches both twin-head pump partners off. The control input of the partner pump only switches the partner pump off.** If the main pump fails or the twin-head pump connection is disconnected, the control input of the partner pump is evaluated.

States	Main pump			Partner pump		
	EXT. OFF	Behaviour of the pump motor	Display text for active influences	EXT. OFF	Behaviour of the pump motor	Display text for active influences
1	Active	Off	OFF Override OFF (DI1)	Active	Off	OFF Override OFF (DI1)
2	Not active	On	OK; normal operation	Active	Off	OFF Override OFF (DI1)
3	Active	Off	OFF Override OFF (DI1)	Not active	Off	OFF Override OFF (DI1)
4	Not active	On	OK; normal operation	Not active	On	OK; normal operation

Table 34: Combined mode



NOTICE

During regular operation, it is preferable to switch the pump on or off via the DI input with EXT. OFF rather than via the mains voltage!

A maximum of 20 switch-on/switch-off cycles per day are permitted via the mains voltage.



NOTICE

The 24 V DC power supply is only available when the analogue input AI1 or AI2 has been configured to a type of use and a signal type or when the digital input DI1 has been configured.

12.7 Application and function of the analogue inputs AI1 and AI2

Analogue inputs can be used for setpoint input or actual value input. The assignment of the target and actual value specifications depends on the selected control mode.

Analogue input AI1 is used as actual value input (sensor value). Analogue input AI2 is used as setpoint input.

Set control mode	Function of analogue input AI1	Function of analogue input AI2
$\Delta p-v$	Configured as actual value input <ul style="list-style-type: none"> Type of use: Differential pressure sensor Configurable: <ul style="list-style-type: none"> Signal type Sensor measuring range Sensor position 	Not configured Can be used as a setpoint input
$\Delta p-c$	Configured as actual value input <ul style="list-style-type: none"> Type of use: Differential pressure sensor Configurable: <ul style="list-style-type: none"> Signal type Sensor measuring range Sensor position 	Not configured Can be used as a setpoint input
n-c	Not used	Not configured Can be used as a setpoint input
PID	Configured as actual value input <ul style="list-style-type: none"> Type of use: any Configurable: <ul style="list-style-type: none"> Signal type 	Not configured Can be used as a setpoint input

Table 35: Application and function of analogue inputs

To change the settings of the analogue inputs, select the following in the menu:

Universal	Display text
1.0	Settings
1.3	External interfaces
1.3.3	Analogue input (AI1)
1.3.4	Analogue input (AI2)

The following table gives an overview of the “Analogue input AI1 and AI2” menu:

Universal	Display text
1.3.3	Analogue input (AI1)
1.3.3.1	Signal type
1.3.3.2	Pressure sensor range
1.3.3.3	Pressure sensor position
1.3.3.3 / 1	Pump flange ¹
1.3.3.3 / 2	Standard-compliant position ²
1.3.4	Analogue input (AI2)
1.3.4.1	Signal type

¹Differential pressure measuring points are located at the drilled holes on the pump flanges of the pump on the discharge and suction side. This sensor position takes into account a flange correction.

²Differential pressure measuring points are located in the piping upstream and downstream of the pump on the discharge and suction side at a distance from the pump.

24 V DC power supply at the analogue input.



NOTICE

The 24 V DC power supply is only available when the analogue input AI1 or AI2 has been configured for a type of use and a signal type.

12.7.1 Using the analogue input AI1 as a sensor input (actual value)

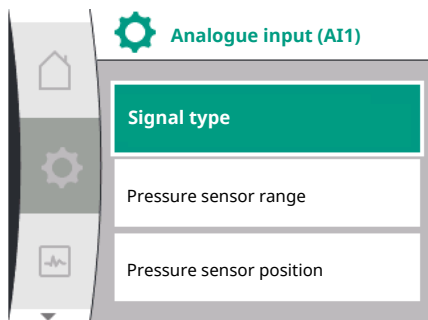

Fig. 75: Analogue input AI1 menu

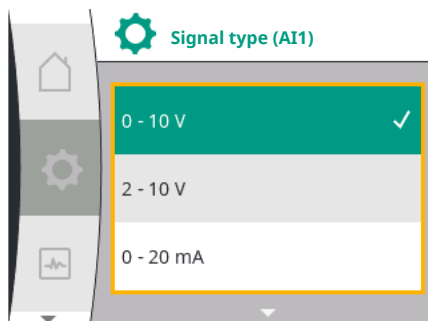

Fig. 76: Signal types menu

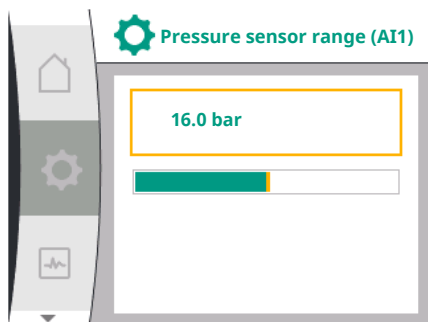

Fig. 77: Setting the pressure sensor range

The actual value sensor provides the following:

- Differential pressure sensor values for differential pressure control
- User-defined sensor values for PID control

When setting the control mode, the type of use of analogue input AI1 as an actual value input (see Table 28) is automatically preconfigured.

To set the signal type, select the following in the menu:

Universal	Display text
1.0	Settings
1.3	External interfaces
1.3.3	Analogue input (AI1)
1.3.3.1	Signal type

Possible signal types when selecting the analogue input as actual value input:

Actual value sensor signal types:

0 – 10 V: Voltage range from 0 to 10 V for the transmission of measured values.

2 to 10 V: voltage range of 2 to 10 V for the transfer of measurement values. A cable break is detected at a voltage below 1 V.

0 to 20 mA: Electric current range from 0 to 20 mA for the transmission of measured values.

4 to 20 mA: electric current range of 4 to 20 mA for transfer of measured values. A cable break is detected if the electric current is less than 2 mA.

For the transfer of analogue signal values to actual values, only the transfer ramp is now defined. The transmission characteristics are fixed and are as follows:

Signal type 2 to 10 V / 4 to 20 mA

Factory setting:

The analogue input AI1 is factory-set with the differential pressure sensor (with variant R1: not assigned) and set to signal type 2 to 10 V.

“Pump flange” is set as the pressure sensor position.

The pressure value set in the factory as the pressure sensor range (see Fig. 75 “Analogue input (AI1)” menu and Fig. 77 “Pressure sensor range (AI1)”) corresponds to the maximum sensor range of the connected differential pressure sensor.

The pressure sensor range varies depending on the pump type.

The sensor range is documented on the rating plate of the differential pressure sensor.

Universal	Display text
1.3.3	Analogue input (AI1)
1.3.3.1	Signal type
1.3.3.2	Pressure sensor range
1.3.3.3	Pressure sensor position
1.3.3.3/1	Pump flange
1.3.3.3/2	Standard-compliant position

The actual value of the differential pressure runs linearly between the analogue signals 2 V and 10 V. This corresponds to 0% to 100% of the sensor measuring range. (See Fig. 78 graph.)

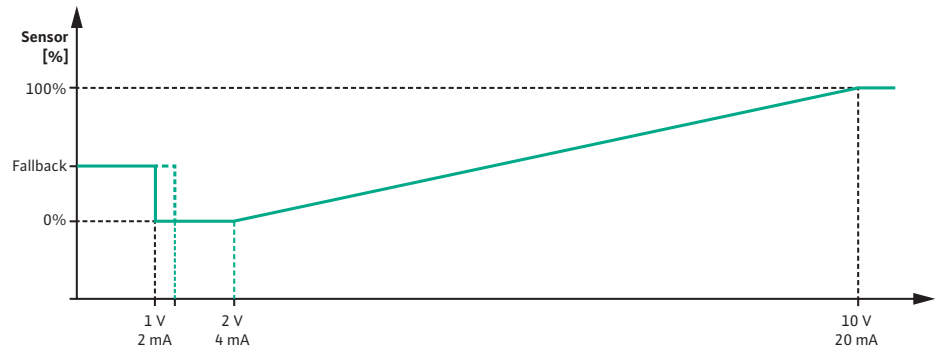

Fig. 78: Behaviour of analogue input AI 1: Sensor value with signal type 2 to 10 V / 4 to 20 mA. The setpoint to which the pump controls is specified according to “Control settings” [▶ 61] section.

The “Cable break detection” function is active.

An analogue signal smaller than 1 V is recognised as a cable break.

A set emergency operation speed is then used as emergency operation. For this, the emergency operation must be set to “Pump ON” in the menu “Control Setting – Emergency Operation” [▶ 64]. If the emergency operation is set to “Pump OFF”, the motor of the pump is switched off when a cable break is detected.

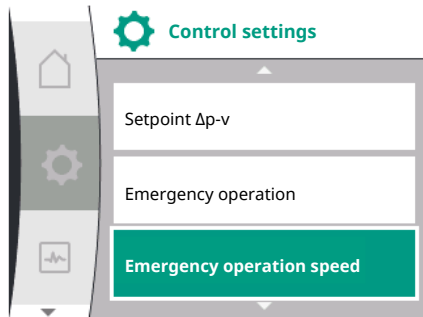

Fig. 79: Control settings menu with emergency operation mode in case of sensor value malfunction

Universal	Display text
1.0	Settings
1.1	Control settings
1.1.7	Emergency operation
OFF	Pump OFF
ON	Pump ON
1.1.8 ³	Emergency operation speed ³

³Menu item only opens when emergency operation is switched to “ON”.

Signal type 2 to 10 V / 4 to 20 mA

Setting up an on-site differential pressure sensor:

If a differential pressure sensor is set up on-site at the analogue input AI1 (for instance for pump version R1), the pressure sensor range and the pressure sensor position must be set for analogue input AI1; see Fig. 75 “Analogue input (AI1)”. Possible pressure sensor positions:

- Pump flange
- Standard-compliant position



NOTICE

Recommendation: Set the pressure sensor range to be set at least as high as the maximum possible delivery head of the respective pump type. The pressure sensor range must be configured in the “Pressure sensor range” menu for this purpose. See Fig. 75 “Analogue input (AI1)” and Fig. 77 “Pressure sensor range (AI1)”.

Example:

If the pump type has a maximum delivery head of 20 m, the differential pressure sensor to be connected must be capable of at least 2.0 bar (approx. 20 m). If a differential pressure sensor with, for example, 4.0 bar is connected, the differential pressure range must be set to 4.0 bar. The appropriate signal type for the differential pressure sensor to be connected must always be selected. In this case 2 to 10 V or 4 to 20 mA.



NOTICE

The differential pressure range to be set must always be set to the nominal maximum value of the connected differential pressure sensor. The nominal maximum value corresponds to the sensor value 100 %. The value must be read from the rating plate of the differential pressure sensor. This is the only way to ensure that the pump controls correctly.

The actual value of the differential pressure runs between the analogue signals 2 to 10 V or 4 to 20 mA. It is linearly interpolated.

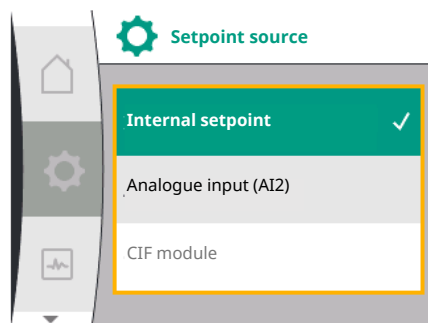

Fig. 80: Setpoint source menu

The applied analogue signal of 2 V or 4 mA represents the actual value of the differential pressure at “0 %”. The applied analogue signal of 10 V or 20 mA represents the actual value of the differential pressure at “100 %”. (See Fig. 81 graph.)

The setpoint to which the pump controls is specified according to “Control settings” section. The adjustment is made in menu “Control setting” [► 61], “Set setpoint source” [► 63]. “Internal setpoint” must be activated.

Universal	Display text
1.0	Settings
1.1	Control settings
1.1.9	Setpoint source
1.1.9 / 1	Internal setpoint
1.1.9 / 2	Analogue input (AI2)
1.1.9 / 3	CIF module

The “Cable break detection” function is active.

An analogue signal smaller than 1 V or 2 mA is recognised as a cable break.

Switching on or off takes a hysteresis into account.

A set emergency operation speed is then used as emergency operation. For this, the emergency operation must be set to “Pump ON” in the menu “Control setting – Emergency operation [► 64]”. If the emergency operation is set to “Pump OFF”, the pump stops when a cable break is detected.

Signal type 0 to 10 V / 0 to 20 mA

Setting up an on-site differential pressure sensor:

If a differential pressure sensor is set up on-site at analogue input AI1 (for instance for pump version R1), the pressure sensor range and the pressure sensor position must be set for analogue input AI1; see Fig. 75 “Analogue input (AI1)”. Possible pressure sensor positions:

- Pump flange
- Standard-compliant position



NOTICE

Recommendation: Set the pressure sensor range to be set at least as high as the maximum possible delivery head of the respective pump type. The pressure sensor range must be configured in the “Pressure sensor range” menu. See Fig. 75 “Analogue input (AI1)” and Fig. 77 “Pressure sensor range (AI1)”.

Example:

If the pump type has a maximum delivery head of 20 m, the differential pressure sensor to be connected must be capable of at least 2.0 bar (approx. 20 m). If a differential pressure sensor with, for example, 4.0 bar is connected, the differential pressure range must be set to 4.0 bar. The appropriate signal type for the differential pressure sensor to be connected must always be selected. In this case 0 to 10 V or 0 to 20 mA.



NOTICE

The differential pressure range that is set must always be set to the nominal maximum value of the connected differential pressure sensor. The nominal maximum value corresponds to the sensor value 100 %. The value must be read from the rating plate of the differential pressure sensor. This is the only way to ensure that the pump controls correctly.

The actual value of the differential pressure runs between the analogue signals 0 to 10 V or 0 to 20 mA. It is interpolated linearly. (See Fig. 81 graph.)

The applied analogue signal of 0 V or 0 mA represents the actual value of the differential pressure at “0%”. The applied analogue signal of 10 V or 20 mA represents the actual value of the differential pressure at “100 %”.

The setpoint to which the pump controls is specified according to “Control settings” section. The adjustment is made in menu “Control setting” [► 61], “Set setpoint source” [► 63]. “Internal setpoint” must be activated.

The “Cable break detection” function is **not active**.

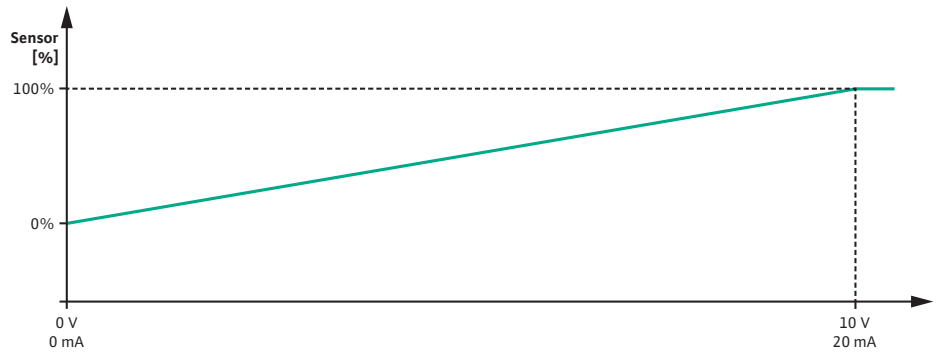

Fig. 81: Behaviour of analogue input AI1: Sensor value with signal type 0 to 10 V / 0 to 20 mA

12.7.2 Using the analogue input AI2 as the setpoint input

The setting of the analogue input AI 2 is only available in the menu if the analogue input AI2 was previously selected in the menu. To do this, select the following in the menu in succession:

Universal	Display text
1.0	Settings
1.1	Control settings
1.1.9	Setpoint source
1.1.9 / 2	Analogue input (AI2)

The signal type is set via the menu “Settings”, “External interfaces”, “Analogue input AI2”.

Universal	Display text
1.0	Settings
1.3	External interfaces
1.3.4	Analogue input (AI2)
1.3.4.1	Signal type

Possible signal types when selecting the analogue input as the setpoint input:

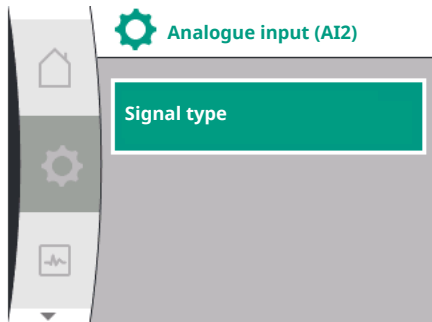

Fig. 82: Analogue input menu (AI2)

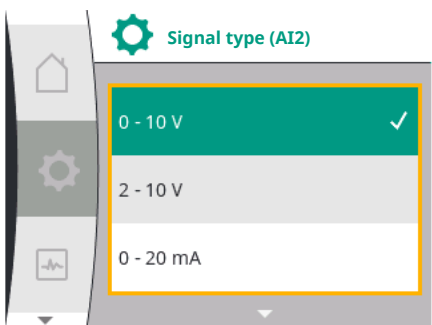

Fig. 83: Signal types menu (AI2)

Setpoint sensor signal types:

- 0 – 10 V:** Voltage range from 0 to 10 V for the transmission of setpoints.
- 2 to 10 V:** Voltage range from 2 to 10 V for transmission of setpoints.
- 0 to 20 mA:** Electric current range from 0 to 20 mA for the transmission of setpoints.
- 4 to 20 mA:** electric current range of 4 to 20 mA for transfer of setpoints.

The analogue input AI2 can only be used as an input for an external setpoint sensor.

Signal type 2 to 10 V / 4 to 20 mA:

If an external setpoint sensor is set up at analogue input AI2, the signal type must be set. In this case 2 to 10 V or 4 to 20 mA.

The analogue signal runs between 5 V to 10 V or between 10 mA to 20 mA. The analogue signal is interpolated linearly. The applied analogue signal of 5 V or 10 mA represents the setpoint (for instance the speed) at “0 %”. The applied analogue signal of 10 V or 20 mA represents the setpoint of the differential pressure at “100%”. (See Fig. 84 graph.)

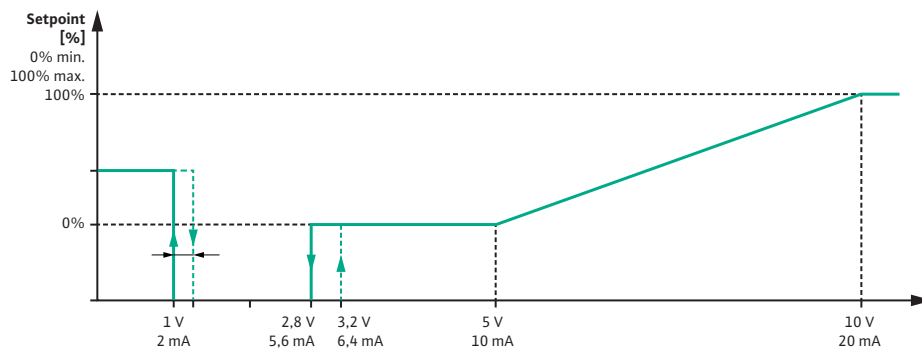

Fig. 84: Behaviour of analogue input AI2: Setpoint with signal type 2 to 10 V / 4 to 20 mA
With an analogue signal between 1 V and 2.8 V or between 2 mA and 5.6 mA, the motor is switched off.

The cable break detection is active.

An analogue signal smaller than 1 V or 2 mA is detected as a cable break. In this case, a set substitute setpoint takes effect. The substitute setpoint is set in the menu “Control settings [▶ 61] –Setting the setpoint source [▶ 63]” (see Fig. 79 “Control settings with emergency operation mode”).

Depending on the set control mode, the following can be set as substitute setpoint:

- A speed (for control mode “Constant speed n-c”)
- A delivery head (for the control modes “Differential pressure Δp -v” and “Differential pressure Δp -c”)

Universal	Display text
1.0	Settings
1.1	Control settings
1.1.10	Substitute setpoint

Signal type 0 to 10 V / 0 to 20 mA:

If an external setpoint sensor is set up at analogue input AI2, the signal type must be set. In this case 0 to 10 V or 0 to 20 mA.

The analogue signal runs between 4 V and 10 V or between 8 mA and 20 mA. The analogue signal is interpolated linearly. The applied analogue signal of 1 V to 4 or 2 mA to 8 mA represents the setpoint value (for instance the speed) at “0 %”. The applied analogue signal of 10 V or 20 mA represents the setpoint of the differential pressure at “100%”. (See Fig. 85 graph.)

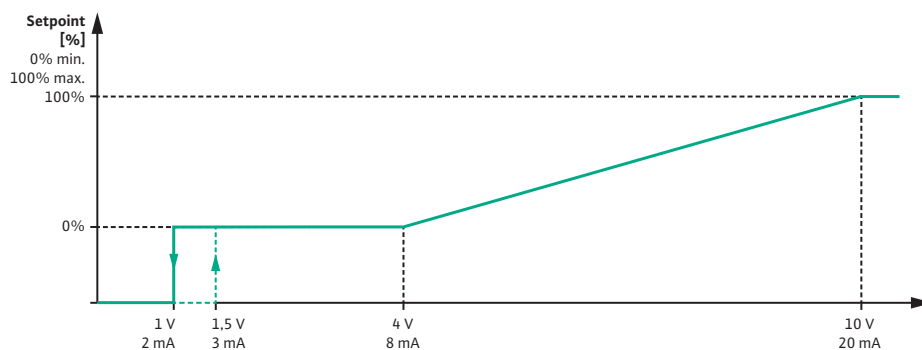

Fig. 85: Behaviour of analogue signal AI2: Setpoint for signal type 0 to 10 V / 0 to 20 mA

If the analogue signal is less than 1 V or 2 mA, the motor is switched off.

The cable break detection is **not** active.



NOTICE

After selecting one of the external sources, the setpoint is coupled to this external source and can no longer be adjusted in the setpoint editor or in the Home screen.

This coupling can only be cancelled in the menu “Setting the setpoint source” [▶ 63]. The setpoint source must be adjusted again to “Internal setpoint”.

The coupling between external source and setpoint is marked both in the



Home screen and in the setpoint editor in **blue**. The status LED also becomes blue.

12.8 Application and function of the Wilo Net interface

Wilo Net is a bus system that Wilo products (participants) can use to communicate with each other.

Application for:

- twin-head pumps consisting of two participants

Bus topology:

The bus topology consists of several pumps (participants) connected in series. The participants are connected via a shared cable.

The bus must be terminated at both ends of the cable. This is done for the two external pumps in the pump menu. All other subscribers should **not** have activated termination.

All bus subscribers must be assigned an individual address (Wilo Net ID).

This address is set in the pump menu of the respective pump.

To schedule the pumps, select the following:

Universal	Display text
1.0	Settings
1.3	External interfaces
1.3.5	Wilo Net setting
1.3.5.1	Wilo Net termination

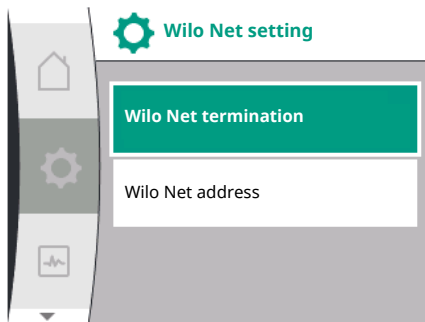

Fig. 86: Wilo Net menu setting

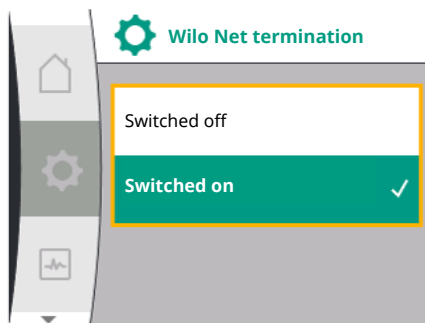

Fig. 87: Wilo Net termination menu

Possible selection:

Wilo Net termination	Description
Switched off	The pump's terminating resistor is switched off. If the pump is NOT connected at the end of the electrical bus line, "Switched off" must be selected.
Switched on	Terminating resistor of the pump is switched on. If the pump is connected at the end of the electrical bus line, "Switched on" must be selected.

After the termination has been changed, an individual Wilo Net address is assigned to the pumps.

To assign the Wilo Net address, select the following:

Universal	Display text
1.0	Settings
1.3	External interfaces
1.3.5	Wilo Net setting
1.3.5.2	Wilo Net address

Each pump must be assigned its own address (1 ... 2).



NOTICE

The setting range for the Wilo Net address is 1 ... 126, all values in the range 22 ... 126 may **not** be used.



Fig. 88: Wilo Net address menu

Twin-head pump example:

- Pump head left (I)
 - Wilo Net termination: ON
 - Wilo Net address: 1
- Pump head right (II)
 - Wilo Net termination: ON

12.9 Application and function of CIF module

– Wilo Net address: 2

Depending on the type of CIF module inserted, a  “Settings”, “External interfaces” associated settings menu is displayed in the menu. The required settings of the CIF modules in the pump are described in the user manual of the CIF modules.

13 Display settings

General settings can be changed under  “Settings”, “Display Settings”.

The following table gives an overview of the “Display settings” menu:

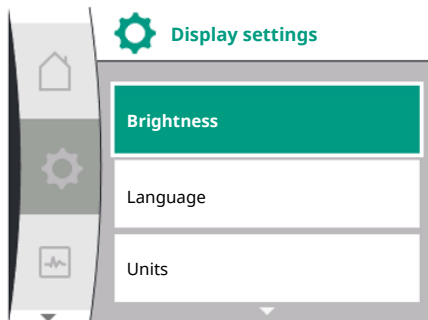



Fig. 89: Display settings menu

Universal	Display text
1.0	Settings
1.5	Display settings
1.5.1	Brightness
1.5.2	Language
English	English
Deutsch	German
Français	French
Universal	Universal
1.5.3	Units
m, m ³ /h	m, m ³ /h
kPa, m ³ /h	kPa, m ³ /h
kPa, l/s	kPa, l/s
ft, USGPM	ft, USGPM
1.5.4	Key lock
1.5.4.1	Key lock ON

13.1 Display brightness

The display brightness can be changed under  “Settings”, “Display settings”. The level of brightness is shown in a percentage. 100 % brightness corresponds to maximum possible, 5 % is the minimum possible brightness.

Universal	Display text
1.0	Settings
1.5	Display settings
1.5.1	Brightness

13.2 Language

The language can be set under  “Settings”, “Display settings”. The following languages can be selected:

Language abbreviations	Language
EN	English
DE	German
FR	French
IT	Italian
ES	Spanish
UNIV	Universal
FI	Finnish
SV	Swedish
PT	Portuguese
NO	Norwegian
NL	Dutch
DA	Danish

Language abbreviations	Language
PL	Polish
HU	Hungarian
CS	Czech
RO	Romanian
SL	Slovenian
HR	Croatian
SK	Slovak
SR	Serbian
LT	Latvian
LV	Lithuanian
ET	Estonian
RU	Russian
UK	Ukrainian
BG	Bulgarian
EL	Greek
TR	Turkish

Table 36: Menu languages



NOTICE

After selecting a language other than the one currently set, the display may switch off and restart.

The green LED flashes during this process. After the display has restarted, the language selection list opens with the activated newly selected language.

This process can take up to approx. 30 sec.



NOTICE

In addition to the languages, there is a neutral number code "Universal" in the display that can be selected as an alternative language. The number code is listed and explained in tables next to the display texts.

Factory setting: English

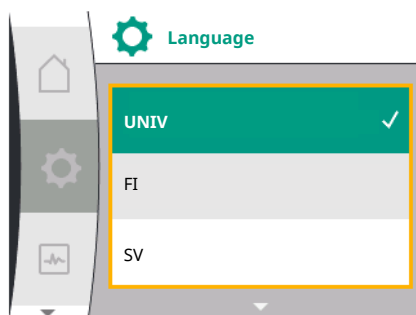



Fig. 90: Menu language

13.3 Unit

Universal	Display text
1.0	Settings
1.5	Display settings
1.5.2	Language
English	English
Deutsch	German
Français	French
•	•
•	•
•	•

The units of the physical values can be set under  "Settings", "Display settings".

Universal	Display text
1.0	Settings
1.5	Display settings
1.5.3	Units
m, m ³ /h	m, m ³ /h

Universal	Display text
kPa, m ³ /h	kPa, m ³ /h
kPa, l/s	kPa, l/s
ft, USGPM	ft, USGPM

Selection options of units:

Units	Description
m, m ³ /h	Representation of physical values in SI units. Exception: • Volume flow in m ³ / h • Delivery head in m
kPa, m ³ /h	Display of the delivery head in kPa and the volume flow in m ³ / h
kPa, l/s	Representation of delivery head in kPa and volume flow in l/s
ft, USGPM	Representation of physical values in US units

Table 37: Units



NOTICE

The units are factory set to m, m³/h.

13.4 Key lock

The key lock function prevents accidental change of pump parameters by unauthorised persons.

The key lock can be activated under  “Settings”, “Display settings”.

Universal	Display text
1.0	Settings
1.5	Display settings
1.5.4	Key lock
1.5.4.1	Key lock ON

Simultaneously pressing (> 5 seconds) the “Back”  button and the operating button deactivates the key lock.

When the key lock is activated, the Home screen and warning and error messages are still displayed in order to monitor the pump status.

The active key lock can be identified in the Home screen by a lock symbol .

14 Additional settings

General settings can be changed under  “Settings”, “Additional settings”.

The following table gives an overview of the “Additional settings” menu:

Universal	Display text
1.0	Settings
1.6	Additional settings
1.6.1	Pump kick
1.6.1.1	Pump kick: ON/OFF
1.6.1.2	Pump kick: Interval
1.6.1.3	Pump kick: Speed
1.6.2	Ramp times
1.6.2.1	Ramp times: Start-up time
1.6.2.2	Ramp times: Switch-off period
1.6.4	Automatic PWM frequency reduction

Universal	Display text
1.6.6	Standstill heating
OFF	Switched off
ON	Switched on

14.1 Pump kick

In order to prevent blocking of the pump, a pump kick is set on the pump. After a set time interval, the pump starts and switches off after a short time.

Prerequisite:

For the pump kick function, the mains voltage must not be interrupted.

CAUTION

Blockage of the pump due to long downtimes!

Long downtimes may lead to blockage of the pump. Do not deactivate pump kick!

Via remote control, bus command, control input EXT. OFF or 0 ... 10 V signal, pumps that have been switched off start up briefly. This prevents blockage after long downtimes.

In the menu  "Settings", "Additional settings"

- The pump kick can be switched on and off.
- The time interval for the pump kick can be set between 2 and 72 hours (for factory setting see "Factory setting" [► 96] section).
- The pump speed at which the pump kick is carried out can be set

Universal	Display text
1.0	Settings
1.6	Additional settings
1.6.1	Pump kick
1.6.1.1	Pump kick: ON/OFF
1.6.1.2	Pump kick: Interval
1.6.1.3	Pump kick: Speed

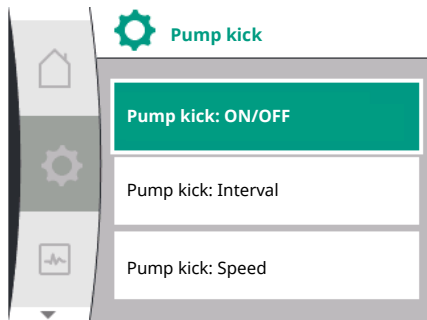

Fig. 91: Pump kick



NOTICE

If a mains disconnection is planned for a longer period of time, the pump kick must be taken over by an external control by briefly switching on the mains voltage.

For this purpose, the pump must be switched on at the control side before the mains disconnection.

14.2 Ramp times for setpoint change

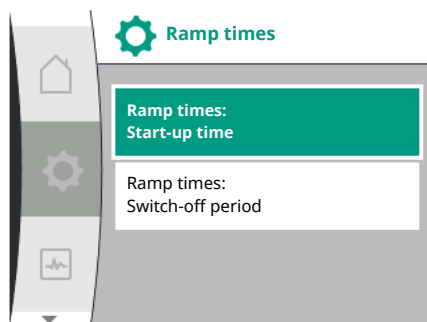



Fig. 92: Ramp times menu

The ramp times of the pumps can be set in the menu  "Settings", "Additional settings".

Universal	Display text
1.0	Settings
1.6	Additional settings
1.6.2	Ramp times
1.6.2.1	Ramp times: Start-up time
1.6.2.2	Ramp times: Switch-off period

The ramp times define the maximum speed at which the pump may ramp up and down when the setpoint is changed.

The adjustable value range for ramping up and down is between 0 s and 180 s. For the factory setting, see "Factory setting" [► 96] section.

14.3 Automatic PWM frequency reduction

The function "Automatic PWM frequency reduction" can be switched on and off in the menu  "Settings", "Additional settings":

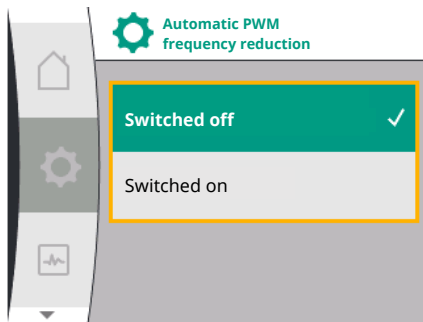

Fig. 93: PWM frequency reduction menu

Universal	Display text
1.0	Settings
1.6	Additional settings
1.6.4	Automatic PWM frequency reduction
OFF	Switched off
ON	Switched on

The function is available depending on type.

The “Automatic PWM frequency reduction” function is switched off in the factory.

If the ambient temperature of the pump is too high, the pump independently reduces the hydraulic output.

If the “Automatic PWM frequency reduction” function is activated, the switching frequency changes from a critical temperature in order to continue supplying the required hydraulic operating point.



NOTICE

A changed switching frequency can lead to higher and/or changed operating noises of the pump.

14.4 Standstill heating

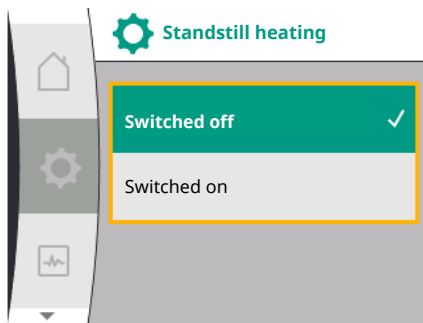

Fig. 94: Standstill heating menu

Universal	Display text
1.0	Settings
1.6	Additional settings
1.6.6	Standstill heating
OFF	Switched off
ON	Switched on

For installation outside a building, always switch on the “standstill heating”.

When the pump is at a standstill, depending on the internal temperature in the electronic module, a voltage is applied to the motor winding and electronic module to heat them up. This reduces condensation water formation.



NOTICE

The standstill heating is only active when the pump is stopped and the interior temperature is below a defined limit value.

If the temperature is above this, the function remains inactive.

15 Diagnostics and measured values

In order to support fault analysis, the pump provides additional help apart from fault notifications:

Diagnostics help is used for diagnosis and maintenance of electronics and interfaces. In addition to hydraulic and electrical overviews, information on interfaces and unit information is displayed.

The following table provides an overview of the menu  “Diagnostics and measured values”:

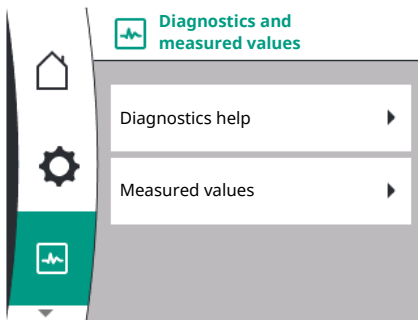

Fig. 95: Diagnostics and measured values

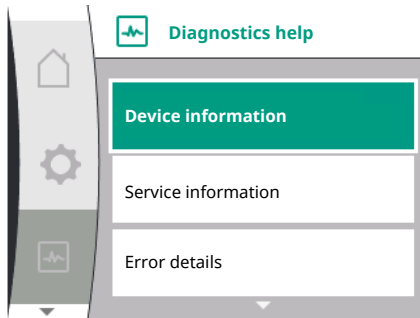



Fig. 96: Diagnostics help menu

Universal	Display text
2.0	Diagnostics and measured values
2.1	Diagnostics help
2.1.1	Device information
2.1.2	Service information
2.1.8	Error details
2.1.3	Overview SSM-relay
Relay function: SSM	Relay function: SSM
Forced control: Yes	Forced control: Yes
Forced control: No	Forced control: No
Current status: Energized	Current status: Energized
Current status: Not energized	Current status: Not energized
2.1.9	Overview SBM-relay
Relay function: SBM	Relay function: SBM
Forced control: Yes	Forced control: Yes
Forced control: No	Forced control: No
Current status: Energized	Current status: Energized
Current status: Not energized	Current status: Not energized
2.1.4	Overview of analogue input (AI1)
Type of use:	Type of use:
Not used	Not used
Differential pressure sensor	Differential pressure sensor
External sensor	External sensor
Setpoint input	Setpoint input
Signal type:	Signal type:
Current value: :	Current value:
2.1.5	Overview of analogue input (AI1)
Type of use:	Type of use:
Not used	Not used
External sensor	External sensor
Setpoint input	Setpoint input
Signal type:	Signal type:
Current value: :	Current value:
2.1.6	Twin-head pump connection info
Partner paired and reachable.	Partner paired and reachable.
Partner is paired.	Partner is paired.
Partner is not reachable.	Partner is not reachable.
Partner WCID: ¹	Partner WCID: ¹
Partner Address:	Partner address:
Partner Name:	Partner name:
2.1.7	Pump cycling status
Time-based pump cycling:	Time-based pump cycling
Switched ON, interval:	Switched on, interval:
Switched OFF	Switched off
Current status:	Current status:

Universal	Display text
No pump is running.	No pump is running.
Both pumps are running.	Both pumps are running.
This pump is running.	This pump is running.
Other pump is running.	Other pump is running.
Next execution in:	Next execution in:
2.2	Measured values
2.2.1	Operating data
H act =	H is =
n act =	n is =
P electr =	P electr =
U mains =	U mains =
2.2.2	Statistical data
W electr =	W electr =
Operating hours =	Operating hours =

¹ WICD = Wilo Communication ID (Communication address of the twin-head pump partner)

15.1 Diagnostics help

There are functions for diagnosis and maintenance of electronics and interfaces in the menu  "Diagnostics and measured values", "Diagnostics help".

The following table provides an overview of the "Diagnostics help" menu:

Universal	Display text
2.1	Diagnostics help
2.1.1	Device information
2.1.2	Service information
2.1.8	Error details
2.1.3	Overview SSM-relay
2.1.9	Overview SBM-relay
2.1.4	Overview of analogue input (AI1)
2.1.5	Overview of analogue input (AI2)
2.1.6	Twin-head pump connection info
2.1.7	Pump cycling status

15.2 Device information

In the "Diagnostics and measured values" menu , you can call up information about product names, the product and serial number as well as software and hardware version. To do this, select the following:

Universal	Display text
2.0	Diagnostics and measured values
2.1	Diagnostics help
2.1.1	Device information

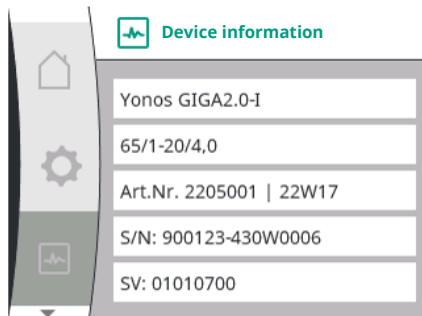



Fig. 97: Menu Device information

15.3 Service information

In the "Diagnostics and measured values" menu , you can call up information on the product for service purposes. To do this, select the following:

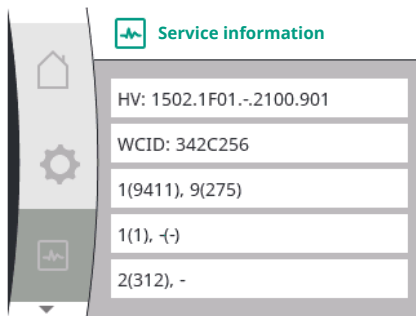

Fig. 98: Menu Service information

15.4 Error details

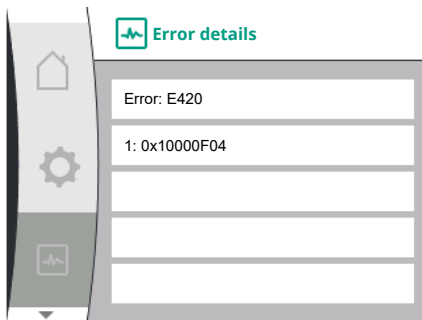

Fig. 99: Error details menu

15.5 Overview of the SSM relay status

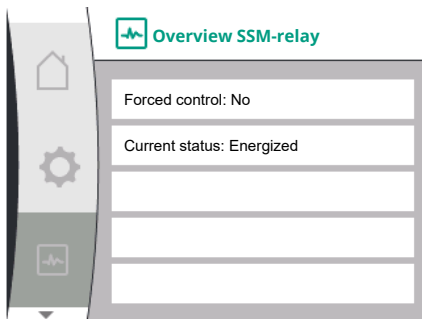

Fig. 100: Overview of the relay function SSM

15.6 Overview of the SBM relay status

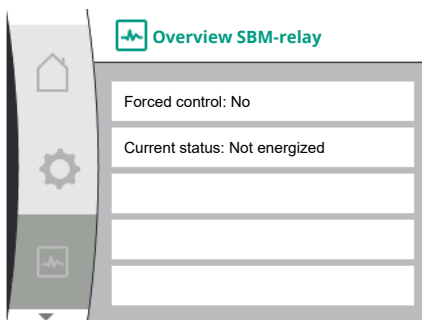



Fig. 101: Overview of the relay function SBM

Universal	Display text
2.0	Diagnostics and measured values
2.1	Diagnostics help
2.1.2	Service information

Universal	Display text
2.0	Diagnostics and measured values
2.1	Diagnostics help
2.1.8	Error details

You can read the status information on the SSM relay in the menu  "Diagnostics and measured values". To do this, select the following:

Universal	Display text
2.0	Diagnostics and measured values
2.1	Diagnostics help
2.1.3	Overview SSM-relay
Relay function: SSM	Relay function: SSM
Forced control: Yes	Forced control: Yes
Forced control: No	Forced control: No
Current status: Energized	Current status: Energized
Current status: Not energized	Current status: Not energized

You can read the status information on the SBM relay in the menu  "Diagnostics and measured values". To do this, select the following:

Universal	Display text
2.0	Diagnostics and measured values
2.1	Diagnostics help
2.1.9	Overview SBM-relay
Relay function: SBM	Relay function: SBM
Forced control: Yes	Forced control: Yes
Forced control: No	Forced control: No
Current status: Energized	Current status: Energized
Current status: Not energized	Current status: Not energized

15.7 Overview of the analogue inputs AI1 and AI2



You can read the status information on the AI1 and AI2 analogue input in the menu “Diagnostics and measured values”. To do this, select the following:

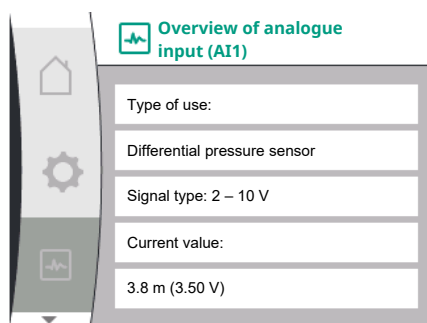

Fig. 102: Overview of analogue input (AI1)

Universal	Display text
2.0	Diagnostics and measured values
2.1	Diagnostics help
2.1.4	Overview of analogue input (AI1)
Type of use:	Type of use:
Not used	Not used
Differential pressure sensor	Differential pressure sensor
External sensor	External sensor
Setpoint input	Setpoint input
Signal type:	Signal type:
Current value: :	Current value:
2.1.5	Overview of analogue input (AI2)
Type of use:	Type of use:
Not used	Not used
External sensor	External sensor
Setpoint input	Setpoint input
Signal type:	Signal type:
Current value: :	Current value:

The following status information is available:

- Type of use
- Signal type
- Current measured value

15.8 Overview of the twin-head pump connection



You can read status information on the twin-head pump connection in the menu “Diagnostics and measured values”. To do this, select the following:

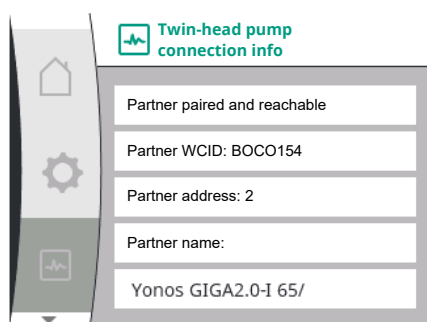

Fig. 103: Information on the twin-head pump connection

Universal	Display text
2.0	Diagnostics and measured values
2.1	Diagnostics help
2.1.6	Twin-head pump connection info
Partner paired and reachable.	Partner paired and reachable.
Partner is paired.	Partner is paired.
Partner is not reachable.	Partner is not reachable.
Partner WCID: ¹	Partner WCID: ¹
Partner Address:	Partner address:
Partner Name:	Partner name:

¹ WCID = Wilo Communication ID (Communication address of the twin-head pump partner)



NOTICE

The twin-head pump connection overview is only available if a twin-head pump connection has been previously configured (see “Dual pump management” [► 65] section).

15.9 Overview of the pump cycling status



You can read the status information on the pump cycling in the menu “Diagnosis and measured values”. To do this, select the following:

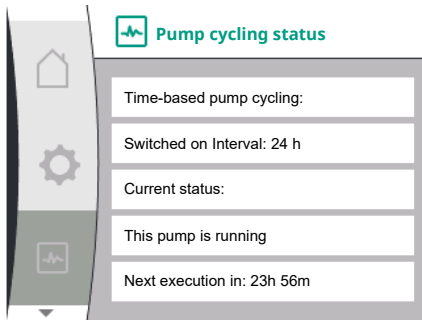

Fig. 104: Information on the pump cycling status

Universal	Display text
2.0	Diagnostics and measured values
2.1	Diagnostics help
2.1.7	Pump cycling status
Time-based pump cycling:	Time-based pump cycling
Switched ON, interval:	Switched on, interval
Switched OFF	Switched off
Current status:	Current status:
No pump is running.	No pump is running.
Both pumps are running.	Both pumps are running.
This pump is running.	This pump is running.
Other pump is running.	Other pump is running.
Next execution in:	Next execution in:

- Pump cycling switched on: yes/no

The following additional information is available when pump cycling is switched on:

- Current status: No pump running / both pumps running / main pump running / pump partner running.
- Time until next pump cycling

15.10 Measured values

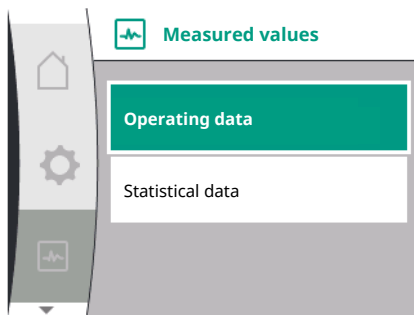



Fig. 105: Measured values menu

You can read operating data, measured values and statistical values in the menu  "Diagnostics and measured values". To do this, select the following in succession:

Universal	Display text
2.0	Diagnostics and measured values
2.2	Measured values
2.2.1	Operating data
H act =	H is =
n act =	n is =
P electr =	P electr =
U mains =	U mains =
2.2.2	Statistical data
W electr =	W electr =
Operating hours =	Operating hours =

The following information is displayed in the "Operating data" submenu:

- Hydraulic operating data
 - Current delivery head
 - Current speed
- Electrical operating data
 - Current electrical power consumption
 - Current power supply on mains side
- Statistical data
 - Total consumed electrical power
 - Operating hours

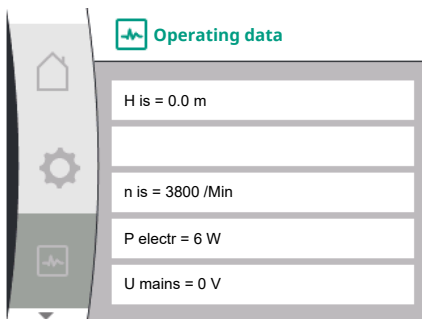

Fig. 106: Operating data

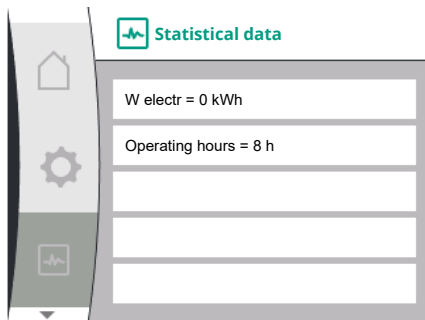

Fig. 107: Statistical data

16 Reset

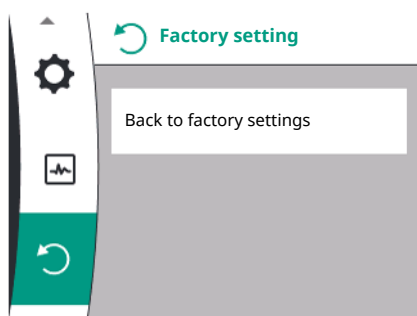

Fig. 108: Resetting to factory setting

16.1 Factory setting

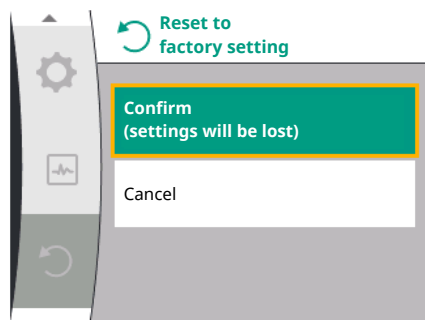



Fig. 109: Confirm reset to factory setting

The pump can be reset to the factory setting in the menu . To do this, select the following:

Universal	Display text
3.0	Factory setting
3.1	Reset to factory setting
Confirm	Confirm (settings will be lost!)
CANCEL	Cancel



NOTICE

Resetting pump settings to factory settings replaces the current pump settings!

The table gives an overview of the factory settings:

Settings	Yonos GIGA2.0	Yonos GIGA2.0 ... R1
Set control mode		
Setting assistant	$\Delta p-v$	Basic control mode n-const.
Pump On/Off	Motor on	Motor on
Twin-head pump operation		
Connecting twin-head pump	Single pump: not connected Twin-head pump: connected	Single pump: not connected Twin-head pump: connected
Twin-head pump alteration	24 h	24 h
External interfaces		
SSM relay		
Function SSM relay	Fault(s) only	Fault(s) only
Trigger delay	5s	5s
Reset delay	5s	5s
SBM relay		
Function SBM relay	Motor in operation	Motor in operation
Trigger delay	5s	5s
Reset delay	5s	5s

Settings	Yonos GIGA2.0	Yonos GIGA2.0 ... R1
DI1	active (with cable bridge)	active (with cable bridge)
A11	configured Type of use: differential pressure sensor Sensor position: pump flange Signal type: 2 ... 10 V	not configured
A12	not configured	not configured
Wilco Net		
Wilco Net termination	switched on	switched on
Wilco Net address	Twin-head pump Main pump: 1 Pump partner: 2 Single pump: 126	Twin-head pump Main pump: 1 Pump partner: 2 Single pump: 126
Display setting		
Language	English	English
Units	m, m ³ /h	m, m ³ /h
Pump kick	switched on	switched on
Pump kick time interval	24 h	24 h
Diagnostics and measured values		
Diagnostics help		
SSM forced control (normal, active, inactive)	inactive	inactive
SBM forced control (normal, active, inactive)	inactive	inactive
Additional settings		
Pump kick	switched on	switched on
Pump kick time interval	24 h	24 h
Basic function	Control mode	Control mode
Ramp time	0 s	0 s
Automatic PWM frequency reduction	switched off	switched off

Table 38: Factory settings

17 Faults, causes and remedies



WARNING

Have faults remedied by qualified personnel only! Observe safety instructions.

In the event of malfunctions occurring, the fault management system provides pump performance and functionalities that can still be achieved.

A fault that has occurred is checked continuously if technically possible and, if possible, emergency operation or control mode is restored.

Malfunction-free pump operation is resumed as soon as the cause of the malfunction no longer exists. Example: The electronic module is again cooled down.



NOTICE

If the pump behaves incorrectly, check that the analogue and digital inputs are configured correctly.

If the malfunction cannot be rectified, consult a specialist technician or the nearest Wilco customer service or representative location.

17.1 Mechanical faults without error messages

Faults	Causes	Remedies
Pump does not start or stops working.	Cable terminal loose.	Check all cable connections.
Pump does not start or stops working.	Fuse protection defect.	Check fuses; replace faulty fuses.
Pump runs at reduced performance.	Stop valve on the discharge side throttled.	Slowly open the stop valve.
Pump runs at reduced performance.	Air in the suction line	Eliminate leakage at flanges. Vent pump. In case of visible leakage, replace the mechanical seal.
Pump makes noises.	Cavitation due to insufficient suction pressure.	Increase the suction pressure. Observe the minimum inlet pressure at the suction port. Check slide valve and filter on the suction side and clean if need be.
Pump makes noises.	Motor has bearing damage.	Have the pump checked by Wilo customer service or a specialised service centre and repaired if necessary.

Table 39: Mechanical faults

17.2 Error messages

Displays an error message on the display

- The status display will be in red colour.
- Error message, error code (E...).

The pump does not pump if an error has occurred. If the pump identifies as part of permanent monitoring that the cause of the error no longer applies, the error message is revoked and operation resumes.

If an error message is output, the display is permanently on and the green LED indicator is off.

The following table gives an overview of possible messages in the display:

Universal	Display text
Error	Fault
Please check operating manual	Check the installation and operating instructions
Double pump	Twin-head pump
This head	Location: This head
Partner head	Location: Partner head
Exists since:	Since
Acknowledge needed	Confirmation required
For acknowledge long press knob	Press and hold the button for acknowledgement
Acknowledged, waiting for restart	Acknowledged, waiting for restart
Reset energy counter	Reset energy counter
Press return key to cancel	Press "Back" to cancel
Press and hold return key to cancel	Press and hold "Back" to cancel
System Notification	System notification
no valid Parameter	No valid parameters
Production mode active	Production mode active
HMI blocked	Display blocked

Code	Fault	Cause	Remedy
401	Unstable power supply	Unstable power supply.	Check the electrical installation.
	Additional information about causes and remedy: Power supply too unstable. Operation cannot be maintained.		
402	Undervoltage	Power supply is too low.	Check the electrical installation.
	Additional information about causes and remedy: Operation cannot be maintained. Possible causes: 1. Mains overloaded. 2. Pump is connected to the wrong power supply.		
403	Overvoltage	Power supply is too high.	Check the electrical installation.
	Additional information about causes and remedy: Operation cannot be maintained. Possible causes: 1. Pump is connected to the wrong power supply.		
404	Pump blocked.	Mechanical influence is inhibiting the rotation of the pump shaft.	Check free movement of rotating parts in the pump head and motor. Remove deposits and foreign substances.
	Additional information on causes and remedies: In addition to deposits and foreign substances in the system, the pump shaft can also be blocked.		
405	Electronic module too hot.	Permissible temperature of the electronic module is exceeded.	Ensure permissible ambient temperature. Improve room ventilation.
	Additional information about causes and remedy: Adhere to permissible installation position and minimum distance from insulation and system components to ensure sufficient ventilation. Keep cooling fins free of deposits.		
406	Motor too hot.	Permissible motor temperature is exceeded.	Ensure permissible ambient and fluid temperature. Ensure motor cooling with unobstructed air circulation.
	Additional information about causes and remedy: Adhere to permissible installation position and minimum distance from insulation and system components to ensure sufficient ventilation.		
407	Connection between motor and module interrupted.	Electrical connection between motor and module faulty.	Check the motor module connection.
	Additional information on causes and remedies: The electronic module can be dismantled to check the contacts between module and motor. Observe the safety instructions!		
408	There is flow through the pump in the opposite direction of flow.	External influences cause flow through against direction of flow of the pump.	Check system function, install swing check valves if necessary.
	Additional information about causes and remedy: If flow passing through pump in the opposite direction is too strong, the motor can no longer start.		
409	Incomplete software update.	The software update was not completed.	Software update with a new software bundle is required.
	Additional information about causes and remedy: The pump can work only once the software update has been completed.		

Code	Fault	Cause	Remedy
410	Analogue / digital input overloaded.	Voltage of analogue / digital input short-circuited or too heavily loaded.	Check cable and consumers connected to power supply of analogue / digital input for short-circuit.
Additional information about causes and remedy: The fault impairs the binary inputs. EXT. OFF is set. The pump is stationary. The power supply is the same for analogue and digital input. In case of over-voltage, both inputs are overloaded equally.			
411	Mains phase missing (only applies to 3~)	No mains phase	Check the electrical installation.
Additional information about causes and remedies: Operation cannot be maintained. Possible causes: 1. Contact fault on mains connection terminal. 2. Fuse of a mains phase has tripped.			
420	Motor or electronic module defective.	Motor or electronic module defective.	Replace motor and/or electronic module.
Additional information about causes and remedy: The pump cannot determine which of the two components is faulty. Contact service.			
421	Electronic module is defective.	Electronic module is defective.	Electronic module is defective.
Additional information about causes and remedy: Contact service.			

Table 40: Error messages

17.3 Warning messages

Warning displayed:

- The status display is marked in yellow.
- Warning message, warning code (W...)

Warnings indicate restricted pump function. The pump continues to operate in restricted mode (emergency operation).

Depending on the cause of the warning, emergency operation leads to a restriction of the control function and even reactivation of a fixed speed.

If the pump identifies as part of permanent monitoring that the cause of the warning no longer applies, the warning is revoked and operation resumes.

If there is a warning message, the display is permanently on and the green LED indicator is off.

The following table gives an overview of possible messages in the display:

Universal	Display text
Warning	Warning
Please check operating manual	Check the installation and operating instructions
Double pump	Twin-head pump
This head	Location: This head
Partner head	Location: Partner head
Exists since:	Since
Acknowledge needed	Confirmation required
For acknowledge long press knob	Press and hold the button for acknowledgement
Acknowledged, waiting for restart	Acknowledged, waiting for restart
Reset energy counter	Reset energy counter
Press return key to cancel	Press "Back" to cancel
Press and hold return key to cancel	Press and hold "Back" to cancel
System Notification	System notification
no valid Parameter	No valid parameters
Production mode active	Production mode active

Universal		Display text	
HMI blocked		Display blocked	
Code	Warning	Cause	Remedy
550	There is flow through the pump in the opposite direction of flow.	External influences cause flow through against direction of flow of the pump.	Check power control of the pumps, install swing check valve if needed.
	Additional information about causes and remedy: If flow passing through pump in the opposite direction is too strong, the motor can no longer start.		
551	Undervoltage	Power supply too low. Power supply has fallen below a minimum limit value.	Check power supply.
	Additional information about causes and remedy: The pump is running. Undervoltage reduces the pump's performance. If the voltage continues to drop, reduced operation cannot be maintained.		
552	There is externally generated flow through the pump in the direction of flow.	External influences cause flow through in the pump's direction of flow.	Check power control of the other pumps.
	Additional information about causes and remedy: The pump can start despite flow through.		
553	Electronic module is defective.	Electronic module is defective.	Replace electronic module.
	Additional information about causes and remedy The pump is running, but cannot provide full power under the circumstances. Contact service.		
555 / 557	Implausible sensor value at analogue input AI1 or AI2.	The configuration and the present signal lead to an unusable sensor value.	Check configuration of the input and connected sensor.
	Additional information about causes and remedy Incorrect sensor values may lead to substitute operation modes that ensure functioning of the pump without the required sensor value.		
556 / 558	Cable break at analogue input AI1 or AI2.	The configuration and the present signal help identify the cable break.	Check configuration of the input and connected sensor.
	Additional information about causes and remedies: Cable break detection may lead to substitute operation modes that ensure operation without the required external value. Twin-head pump: If W556 appears in the partner pump display without a differential pressure sensor connected, always check the dual pump connection as well.. W571 may also be activated, however it is not displayed with the same priority as W556. The partner pump without a connected differential pressure sensor interprets itself as a single pump due to the missing connection to the main pump. In this case, it recognises the unconnected differential pressure sensor as a cable break.		
560	Incomplete software update.	The software update was not completed.	Software update with new software bundle is recommended.
	Additional information about causes and remedy: Software update was not carried out; pump continues to operate with previous software version.		
561	Digital input overloaded (binary).	Voltage digital input short-circuited or too heavily loaded.	Check cable and consumers connected to power supply of digital input for short-circuit.
	Additional information about causes and remedy: Binary inputs are impaired. Functions of binary inputs are not available.		

Code	Warning	Cause	Remedy
562	Analogue input over-loaded (analogue).	Voltage analogue input short-circuited or too heavily loaded.	Check the cables and consumers connected to the analogue input power supply for short circuits.
Additional information about causes and remedy: Analogue input functions impaired.			
564	BMS ¹⁾ setpoint is missing.	Sensor source or BMS ¹⁾ is configured incorrectly. Communication has failed.	Check configuration and function of BMS ¹⁾ .
Additional information about causes and remedy: Control functions impaired. A replacement function is active.			
565 / 566	Signal too strong at analogue input AI1 or AI2.	The available signal is significantly over the expected maximum.	Check input signal.
Additional information about causes and remedy: The signal is processed with the maximum value.			
570	Electronic module too hot.	Critical temperature of the electronic module exceeded.	Ensure permissible ambient temperature. Improve room ventilation.
Additional information about causes and remedies: The electronic module must adjust the pump's operation in the event of noticeable overheating to prevent damage to electronic components.			
571	Connection to two-pump system interrupted.	The connection to the partner in the two-pump system cannot be established.	Check power supply of the partner in the two-pump system, cable connection and configuration.
Additional information about causes and remedy: Pump function slightly impaired. The motor head meets the pump function up to the performance limit. See also additional information for code 582.			
573	Communication to display and operating unit interrupted.	Internal communication to display and operating unit interrupted.	Check the ribbon cable connection.
Additional information about causes and remedies: The display and operating unit is connected to the pump's electronics on its rear side via a ribbon cable.			
574	Communication to CIF module interrupted.	Internal communication to the CIF module interrupted.	Check/clean contacts between CIF module and electronic module.
Additional information about causes and remedy: The CIF module is connected to the pump in the terminal box via four contacts.			
578	Display and operating unit defective.	A fault in the display and operating unit has been identified.	Replace display and operating unit.
Additional information about causes and remedy: The display and operating unit is available as a spare part.			
582	Two-pump system is not compatible.	Partner in the two-pump system is not compatible with this pump.	Select/install appropriate dual-pump partner.
Additional information about causes and remedy: The two-pump system function is only possible with two compatible pumps of the same type. Check the compatibility of the software versions of both partners in the two-pump system. Contact service.			

Code	Warning	Cause	Remedy
586	Overvoltage	Power supply is too high.	Check power supply
Additional information about causes and remedy: The pump is running. If the voltage continues to increase, the pump is shut down. Excessive voltages can damage the pump.			
588	Electronic fan blocked, defective or not connected.	Electronic fan does not work	Check the fan cable.
657	Delivery head/flow unknown	The delivery head and/or flow rate are required.	Connect the differential pressure sensor to the pump and configure it.
The pump functions in a substitute operation mode that maintains pump operation.			

¹⁾ BMS = Building management system



NOTICE

The warning W573 "Communication to the display and control unit interrupted", is shown differently from all other warnings on the display.

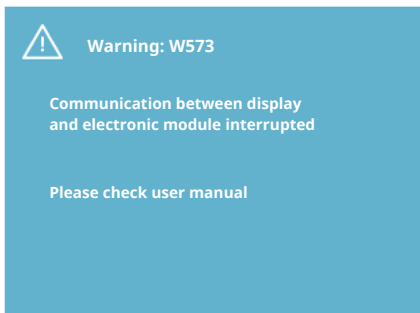

Fig. 110: Warning W573

Universal	Display text
Warning: W573	Warning W573
Communication between display and electronic module interrupted Please check operating manual Please check operating manual	Communication between display and electronic module interrupted. Please check in user manual.

18 Maintenance

- Maintenance work: The technician must be familiar with the use of operating fluids and their disposal.
- Electrical work: a qualified electrician must carry out the electrical work.
- Installation/dismantling: The technician must be trained in the use of the necessary tools and fixation materials.

It is recommended to have the pump serviced and checked by the Wilo customer service.



DANGER

Risk of fatal injury due to electrical current!

Improper conduct when carrying out electrical work can lead to death due to electric shock!

- Any work on electrical devices may only be carried out by a qualified electrician.
- Before carrying out any work, disconnect the unit from the power supply and secure it against accidental switch-on.
- Any damage to the pump connection cable should only ever be rectified by a qualified electrician.
- Never poke around in the openings of the motor or electronic module or insert anything into them.
- Follow the installation and operating instructions for the pump, level control device and other accessories.
- After completing the work, refit previously dismantled protective devices, for example, covers or coupling covers.



DANGER

When dismantled, the permanent magnet rotor inside the pump can pose mortal danger for people with medical implants (e.g. pacemakers).

- Follow the general behavioural guidelines that apply to handling electrical devices!
- Do not open the motor!
- Dismantling and installation of the rotor may only be carried out by Wilo customer service! If you have been fitted with a pacemaker, you must **not** carry out this kind of work!



NOTICE

The magnets inside the motor do not pose a danger **provided the motor is completely assembled**. Persons with pacemakers can approach a Yonos GIGA2.0 without restriction.



WARNING

Personal injury due to strong magnetic forces!

Opening the motor leads to high, abruptly occurring magnetic forces. This can lead to serious cuts, crushing injuries and bruises.

- Do not open the motor!
- Only allow Wilo customer service to dismantle and install the motor flange and the bearing plate for maintenance and repair work!



DANGER

Risk of fatal electrical shock! Generator or turbine operation during pump flow!

Even without the electronic module (without electrical connection), there may be dangerous contact voltage at the motor contacts!

- Check for absence of voltage and cover or cordon off adjacent live parts!
- Close the shut-off devices upstream and downstream of the pump!



DANGER

Potentially fatal injury due to electronic module not being installed!

A life-threatening voltage may be present at the motor contacts! Normal operation of the pump is only permitted with the electronic module installed.

- Never connect or operate the pump without the electronic module mounted!



DANGER

Danger of death from falling parts!

The pump itself and pump parts can have a very high net weight. Falling parts pose a risk of cuts, crush injuries, bruises or impacts, which can be fatal.

- Always use suitable lifting accessories and secure parts against falling.
- Never stand below a suspended load.
- During storage and transport, as well as before all installation and assembly work, ensure that the pump is in a safe position and standing securely.

**DANGER****Danger of death due to ejected tools!**

The tools used during maintenance work on the motor shaft can be thrown away if they come into contact with rotating parts. Injuries and even death are possible!

- The tools used during maintenance work must be removed completely before the pump is started up!

**WARNING****There is a risk of burns or freezing upon coming into contact with the pump/system.**

Depending on the pump and system operating conditions (fluid temperature), the entire pump can become very hot or very cold.

- Keep a safe distance during operation!
- Allow the system and pump to cool down to room temperature!
- Always wear protective clothing, safety gloves and safety glasses when working.

18.1 Air supply

Check the air supply to the motor housing and electronic module at regular intervals. Dirt impairs the cooling of the motor. If necessary, remove dirt and restore unrestricted air supply.

18.2 Maintenance tasks**DANGER****Danger of death from falling parts!**

Falling pumps or individual pump components may result in life-threatening injuries!

- During installation work, secure pump components against falling down with suitable lifting gear.

**DANGER****Risk of fatal electrical shock!**

Check for absence of voltage and cover or cordon off adjacent live parts.

18.2.1 Replacing the mechanical seal

There may be a slight amount of drip leakage during the running-in period. Even during normal operation of the pump, it is normal for there to be slight leakage with the occasional formation of drops.

A regular visual inspection is required. If leakage is clearly visible, replace the gasket.

For further information, see also Wilo Consulting guide for glanded pumps.

Wilo offers a repair kit which contains the necessary parts for replacement.

**NOTICE**

The magnets inside the motor do not pose a risk to persons with pacemakers provided that the motor is not opened and the rotor is not dismantled. The mechanical seal can be replaced without any risk.

Dismantling (0.37 kW to 7.5 kW):**WARNING****Risk of scalding!**

At high fluid temperatures and system pressures, allow the pump to cool down first and then depressurise the system.

1. Disconnect the system from the power supply and secure it against being switched on again without authorisation.
2. Close the shut-off devices upstream and downstream of the pump.

3. Make sure it is not live.
4. Earth the work area and short-circuit.
5. Loosen the screws of the electronic module (Fig. I, Item 3) and remove the upper part of the electronic module (Fig. I, Item 2)
6. Disconnect mains connection cable. If present, remove the cable of the differential pressure sensor on the DDG.
7. Depressurise the pump by opening the air vent valve (Fig. I, Item 28).



NOTICE

It is recommended to dismantle the module for better handling prior to dismantling the motor impeller unit (see “Replacing the electronic module” [► 111] section).

8. Leave two transport lugs (Fig. I, Item 30) on the motor flange.
9. Secure the motor impeller unit at the transport lugs with suitable lifting accessories (Fig. 7).
⇒ **Version according to Fig. I**
10. Remove the motor impeller unit (see “Description of the pump” [► 16] section) from the pump housing by loosening the flange screws (Fig. I, Item 29).



NOTICE

Avoid damaging the plastic parts such as the upper part of the module while attaching the lifting accessory.

11. Removing the screws (Fig. I, Item 29) also detaches the differential pressure sensor from the motor flange. Suspend the differential pressure sensor (Fig. I, Item 8) with the holder (Fig. I, Item 13) from the pressure measuring lines (Fig. I, Item 7).
12. Remove the O-ring (Fig. I, Item 19).
13. Remove the front retaining ring (Fig. I, Item 36a) from the shaft.
14. Pull the impeller (Fig. II, Item 21) off the shaft.
15. Remove the rear retaining ring (Fig. I, Item 36b) from the shaft.
16. Pull the spacer (Fig. I, Item 20) off the shaft.
17. Pull the mechanical seal (Fig. I, Item 25) off the shaft.
18. Press the stationary ring (Fig. I, Item 26) of the mechanical seal out of the seat in the motor flange and clean the seat surfaces.
19. Clean the seating surfaces of the shaft carefully.
⇒ **Version according to Fig. II**
20. Loosen and remove the screws (Fig. II, Item 29).
21. Loosen and remove the screws (Fig. II, Item 10). The motor impeller unit remains securely in the pump housing after the screws have been removed. There is no tipping hazard even if the motor shaft is horizontal.



NOTICE

The best tool for removing the screws (Fig. II, Item 10) is an angle spanner or socket wrench with a spherical head, especially for pump types with tight spaces.

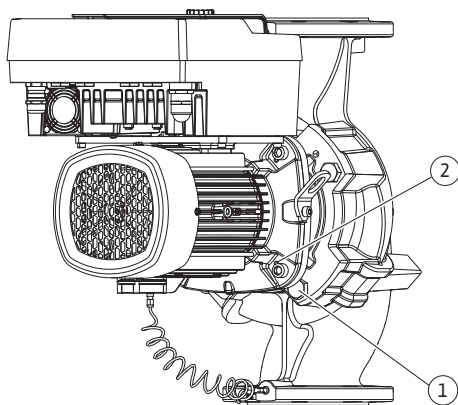

Fig. 111: Pushing off the motor impeller unit via threaded holes (depending on pump type)

22. Removing the screws (Fig. II, Item 10), also detaches the differential pressure sensor from the motor flange. Suspend the differential pressure sensor (Fig. I, Item 8) with the holder (Fig. I, Item 13) from the pressure measuring lines (Fig. I, Item 7). Disconnect the connection cable of the differential pressure sensor in the electronic module.
23. Press the motor impeller unit out of the pump housing. Use the two threaded holes (see Fig. 111, Item 1) for this purpose.
24. Screw M10 screws with a suitable length into the threaded holes to loosen the seat. After being pressed out by approx. 40 mm, the motor impeller unit will no longer be guided in the pump housing.



NOTICE

In order to avoid tipping, the motor impeller unit may have to be supported with suitable lifting equipment. This is especially the case if no mounting bolts are used.

25. Release the two non-detachable screws from the protective plate (Fig. II, Item 27) and remove the protective plate.
26. Loosen the impeller fastening nut (Fig. II, Item 22). Remove the conical spring washer (Fig. II, Item 23) underneath and pull the impeller (Fig. II, Item 21) off the pump shaft. Disassemble key (Fig. II Item 37).
27. Loosen the screws (Fig. II, Item 10a).
28. Release the lantern from the motor centring device with a two-arm puller (universal puller) and pull it off the shaft. The mechanical seal (Fig. II Item 25) is removed at the same time. Avoid jamming the lantern.
29. Push the stationary ring (Fig. II, Item 26) of the mechanical seal out of its seat in the lantern.
30. Carefully clean the seat areas on the shaft and the lantern.
⇒ **Version according to Fig. III**
31. Remove the motor impeller unit (see “Description of the pump” section) from the pump housing by loosening the flange screws (Fig. I/III, Item 29).
32. Removing the screws (Fig. I/III, Item 29) also detaches the differential pressure sensor from the motor flange. Suspend the differential pressure sensor (Fig. I, Item 8) with the holder (Fig. I, Item 13) from the pressure measuring lines (Fig. I, Item 7). Disconnect the connection cable of the DDG in the electronic module or loosen and remove it from the plug connection.
33. To press the motor impeller unit out of the pump housing, use the two adjacent threaded holes (Fig. 111, Item 1) and use existing or suitable screws provided on-site (e.g. M10 x 25 mm).
34. Insert an open-end wrench (SW32 mm) into the lantern window (Fig. III, Item 38) and hold the shaft by the wrench flats. Loosen impeller nut (Fig. III, Item 22). Remove the discs (Fig. III, Item 23) underneath and pull the impeller (Fig. III, Item 21) off the pump shaft. Disassemble key (Fig. III, Item 37).
35. Remove mechanical seal (Fig. III, Item 25) and spacer (Fig. III, Item 20).
36. Remove the stationary ring (Fig. III, Item 26) of the mechanical seal out of its seat in the lantern.
37. Carefully clean the seat areas on the shaft and the lantern.

Installation (0.37 kW to 7.5 kW):



NOTICE

For all the following work, observe the screw tightening torque specified for the respective thread type (“Tightening torques” ► 34] table)!

Elastomers (O-ring, mechanical seal bellows) are easier to install with “wetted water” (e.g. mixture of water and washing up liquid).

1. Clean the flange support and centring surfaces of the pump housing, lantern and motor flange to ensure proper positioning of the parts.
⇒ **Version according to Fig. I**
2. Insert new stationary ring (Fig. I, Item 26) into the lantern piece.
3. Push the new mechanical seal (Fig. I, Item 25) onto the shaft. Avoid damaging the mechanical seal by jamming it.
4. Push the new spacer (Fig. I, Item 20) onto the shaft.
5. Push the rear retaining ring (Fig. I, Item 36b) onto the pump shaft.
6. Fit the impeller (Fig. I, Item 21) onto the shaft.
7. Push the front retaining ring (Fig. I, Item 36a) onto the pump shaft.
8. Insert new O-ring (Fig. I, Item 19).
9. Insert the motor/drive with impeller and shaft seal into the pump housing. Screw in the flange screws (Fig. I, Item 29), but do not finally tighten them yet.
⇒ **Version according to Fig. II**

10. Insert the new stationary ring (Fig. II, Item 26) into the lantern piece. Carefully push the lantern over the shaft and position it in the old position or another desired angular position relative to the motor flange. Observe permitted installation positions of the components (see “Permitted installation positions and change of the arrangement of components before installation” [► 27] section).
11. Screw in the screws (Fig. II, Item 10 and Item 10a). However, do not tighten the screw (Item 10) completely.
12. Pull the new mechanical seal (Fig. II, Item 25) onto the shaft. Avoid damaging the mechanical seal by jamming it.
13. Push the new spacer (Fig. II, Item 20) onto the shaft.
14. Install the impeller with washer(s) and nut, countering at the impeller’s outer diameter while doing so.
15. Clean the lantern groove and insert the new O-ring (Fig. II, Item 19).
16. Attach motor impeller unit to the transport lugs with suitable lifting equipment for protection. When attaching, avoid damaging plastic parts such as the fan wheel and the upper part of the electronic module.
17. Insert the motor impeller unit (see Fig. 5) into the pump housing in the old or another desired angular position. Observe permitted installation positions of the components (see “Permitted installation positions and change of the arrangement of components before installation” [► 27] section).
18. Once the lantern guide has firmly engaged, (about 15 mm before the end position), there is no longer any danger of tipping or tilting. After securing the motor impeller unit with at least one screw (Fig. II, Item 29), the fixation can be removed from the transport lugs.
19. Screw in the screws (Fig. II, Item 29). The motor impeller unit is drawn into the pump housing whilst the screws are being screwed in.
⇒ **Version according to Fig. III**
20. Insert new stationary ring (Fig. III, Item 26) into the lantern.
21. Push the new mechanical seal (Fig. III, Item 25) onto the shaft. Avoid damaging the mechanical seal by jamming it.
22. Push the new spacer (Fig. III, Item 20) onto the shaft.
23. Insert an open-end wrench (SW32 mm) into the lantern window (Fig. III, Item 38) and hold the shaft by the wrench flats. Install impeller with discs and nut and tighten nut.
24. Clean the lantern groove and insert the new O-ring (Fig. III, Item 19).
25. Attach motor impeller unit to the transport lugs with suitable lifting equipment for protection. When attaching, avoid damaging plastic parts such as the fan wheel and the upper part of the electronic module.
⇒ **The following applies for all 3 versions:**
26. If the electronic module was dismantled, it must now be reassembled. See “Replacing the electronic module” [► 111] section

CAUTION

Damage due to incorrect handling!

While screwing in the screws, check the rotatability of the shaft by turning it slightly. To do this, insert an Allen key through the opening in the fan cover (Fig. 6). If the shaft is difficult to move, tighten the screws alternately and diagonally.

-
27. Clamp the holder (Fig. I, Item 13) of the differential pressure sensor under one of the screw heads (Fig. I, Item 29 or Fig. II, Item 10) on the side opposite the electronic module. Finally, tighten the screws (Fig. I, Item 29 or Fig. II, Item 10).



NOTICE

Observe the commissioning measures (see “Commissioning” [► 51] section).

-
28. Re-clamp the connection cable of the differential pressure sensor/mains cable.
 29. Open the shut-off devices upstream and downstream of the pump.
 30. Reset the fuse.

Dismantling (11 kW to 22 kW):**WARNING****Risk of scalding!**

At high fluid temperatures and system pressures, allow the pump to cool down first and then depressurise the system.

1. Disconnect the system from the power supply and secure it against being switched on again without authorisation.
2. Make sure it is not live.
3. Earth the work area and short-circuit.
4. Close the shut-off devices upstream and downstream of the pump.
5. Disconnect the mains connection cable. If present, remove the cable for the differential pressure sensor.
6. Depressurise the pump by opening the air vent valve (Fig. IV to VI, Item 1.31).
7. If present, remove the pressure measurement lines of the differential pressure sensor.
8. Disconnect the mains connection cables if the cable is too short for dismantling the drive.
9. Remove the coupling guard (Fig. IV to VI, Item 1.32) using a suitable tool (e.g. screw-driver).
10. Loosen the coupling screws (Fig. IV to VI, Item 1.5) on the coupling unit.
11. Loosen the motor fastening screws (Fig. IV to VI, Item 5) on the motor flange and lift the drive off the pump with suitable hoisting gear.
12. By loosening the lantern fastening screws (Fig. IV to VII, Item 4), dismantle the lantern unit with coupling, shaft, mechanical seal and impeller from the pump housing.
13. Loosen the impeller fastening nut (Fig. IV to VI, Item 1.11), remove the conical spring washer beneath it (Fig. IV to VI, Item 1.12) and pull the impeller (Fig. IV to VI, Item 1.13) from the pump shaft.
14. Dismantle the shim (Fig. V, Item 1.16) and if required the key (Fig. V, Item 1.43).
15. Pull the mechanical seal (Fig. IV to VI, Item 1.21) off the shaft.
16. Pull the coupling (Fig. IV to VI, Item 1.5) with the pump shaft out of the lantern.
17. Thoroughly clean the sliding/seat surfaces of the shaft. If the shaft is damaged, also replace the shaft.
18. Remove the stationary ring on the mechanical seal with the collar from the lantern flange and the O-ring (Fig. IV to VI, Item 1.14). Clean the gasket seats.

Installation (11 kW to 22 kW):**NOTICE**

For all the following work, observe the screw tightening torque specified for the respective thread type ("Tightening torques" ► 34] table)!

1. Press a new mechanical seal stationary ring with collar into the gasket seat of the lantern flange. A commercially available dishwashing liquid can be used as a lubricant.
2. Install a new O-ring in the groove of the O-ring seat of the lantern.
3. Check the coupling sliding surfaces, if necessary, clean and slightly oil them.
4. Pre-install the coupling shells on the pump shaft with spacer shims inserted in between and insert the pre-assembled coupling shaft unit carefully into the lantern.
5. Pull a new mechanical seal onto the shaft. A commercially available dishwashing liquid can be used as a lubricant (if required, insert the key and the shim again).
6. Install the impeller with washer(s) and nut, countering at the impeller's outer diameter while doing so. Avoid damage to the mechanical seal due to jamming.
7. Insert the pre-assembled lantern unit carefully into the pump housing and screw together. As you do so, prop the shaft-impeller unit on the coupling to avoid damage to the mechanical seal.
8. Slightly loosen the coupling screws. Slightly open the pre-assembled coupling.
9. Install the motor using suitable hoisting gear and tighten the connection between lantern and motor.

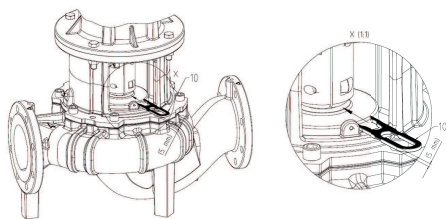
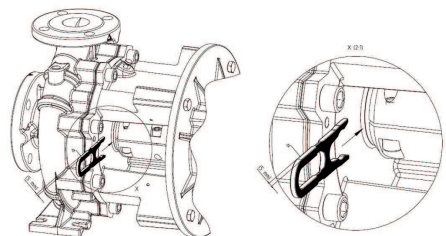

Fig. 112: Positioning the forked spacer



18.2.2 Replacing the motor/drive

10. Push the forked spacer (Fig. 112) between the lantern and coupling. The forked spacer must sit there without any play.
11. First, slightly tighten the coupling screws (Fig. IV to VI, Item 1.5) until the coupling half-shells are in contact with the shims.
12. Afterwards, screw the coupling together evenly. In doing so, the specified distance between the lantern and the coupling of 5 mm is automatically adjusted via the forked spacer.
13. Remove the forked spacer.
14. If present, attach the pressure measurement lines of the differential pressure sensor.
15. Install the coupling guard.
16. Reattach the mains connection and, if present, the cable of the differential pressure sensor.



NOTICE

Observe the commissioning measures (see “Commissioning” section).

17. Open the shut-off devices upstream and downstream of the pump.
18. Reset the fuse.

Increased bearing noises and unusual vibrations indicate bearing wear. The bearings or motor must then be replaced. The drive may only be replaced by the Wilo customer service!



DANGER

Risk of fatal electrical shock! Generator or turbine operation during pump flow!

Even without the electronic module (without electrical connection), there may be dangerous contact voltage at the motor contacts!

- Check for absence of voltage and cover or cordon off adjacent live parts!
- Close the shut-off devices upstream and downstream of the pump!



WARNING

Personal injury due to strong magnetic forces!

Opening the motor leads to high, abruptly occurring magnetic forces. This can lead to serious cuts, crushing injuries and bruises.

- Do not open the motor!
- Only allow Wilo customer service to dismantle and install the motor flange and the end shield for maintenance and repair work!



NOTICE

The magnets inside the motor do not pose a risk to persons with pacemakers provided that the motor is not opened and the rotor is not dismantled. The motor/drive can be replaced without any risk.

Dismantling (0.37 kW to 7.5 kW):

1. To dismantle the motor, carry out steps 1 to 8 according to “Replacing the mechanical seal” [► 105] section.
2. Remove the screws (Fig. I, Item 4) and pull the electronic module vertically upwards (Fig. I, Item 1).
⇒ **Version according to Fig. I**
3. Remove the motor/drive with impeller and shaft seal from the pump housing by loosening the flange screws (Fig. I, Item 29).
4. Removing the screws (Fig. I, Item 29) also detaches the differential pressure sensor from the motor flange. Suspend the differential pressure sensor (Fig. I, Item 8) with the holder (Fig. I, Item 13) from the pressure measuring lines (Fig. I, Item 7).
⇒ **Version according to Fig. II**

5. To dismantle the motor, carry out steps 20 to 30 according to “Replacing the mechanical seal” [▶ 105] section.
⇒ **Version according to Fig. III**
6. To dismantle the motor, carry out steps 31 to 34 according to “Replacing the mechanical seal” [▶ 105] section.

Installation (0.37 kW to 7.5 kW):

1. Clean the flange support and centring surfaces of the pump housing, lantern and motor flange to ensure proper positioning of the parts.
⇒ **Version according to Fig. I**
2. Insert the motor/drive with impeller and shaft seal into the pump housing and screw in the flange screws (Fig. I, Item 29), but do not finally tighten them yet.
3. Before installing the electronic module, pull the new O-ring (Fig. I, Item 31) between the electronic module (Fig. I, Item 1) and the motor adapter (Fig. I, Item 11) onto the contacting chamber.
4. Press the electronic module into the new motor contacting and fasten with screws (Fig. I, Item 4).
5. To install the drive, carry out steps 19 to 23 and 25 to 30. See “Replacing the mechanical seal” [▶ 105], “Installation” section.
⇒ **Version according to Fig. II**
6. To install the drive, carry out steps 10 to 18 and 25 to 30. See “Replacing the mechanical seal” [▶ 105], “Installation” section.
7. Before installing the electronic module, pull the new O-ring (Fig. I, Item 31) between the electronic module (Fig. I, Item 1) and the motor adapter (Fig. I, Item 11) onto the contacting chamber.
8. Press the electronic module into the new motor contacting and fasten with screws (Fig. I, Item 4).
9. To install the drive, carry out steps 19 to 23, see “Replacing the mechanical seal” [▶ 105], “Installation” section.
⇒ **Version according to Fig. III**
10. To install the drive, carry out steps 19 to 30. See “Replacing the mechanical seal” [▶ 105], “Installation” section.
11. Before installing the electronic module, pull the new O-ring (Fig. I, Item 31) between the electronic module (Fig. I, Item 1) and the motor adapter (Fig. I, Item 11) onto the contacting chamber.
12. Press the electronic module into the new motor contacting and fasten with screws (Fig. I, Item 4).
13. To install the drive, carry out steps 19 to 23, see “Replacing the mechanical seal” [▶ 105], “Installation” section.



NOTICE

The electronic module must be pressed on as far as possible when it is installed.

Dismantling (11 kW to 22 kW):

1. Carry out steps 1 to 18 to dismantle the motor/drive in accordance with “Replacing the mechanical seal” [▶ 105] section.

Installation (11 kW to 22 kW):

1. Carry out installation steps 18 to 1 to install the drive, as described in “Replacing the mechanical seal”.

18.2.3 Replacing the electronic module



NOTICE

Before ordering an electronic module as a replacement for dual-pump operation, check the software version of the remaining dual-pump partner.

The software of both dual-pump partners must be compatible. Contact service.

Always observe the section “Commissioning” before carrying out any work!

**DANGER****Risk of fatal electric shock!**

If the rotor is driven via the impeller when the pump is at a standstill, a dangerous contact voltage can occur at the motor contacts.

- Close the shut-off device upstream and downstream of the pump.

**DANGER****Risk of fatal electrical shock! Generator or turbine operation during pump flow!**

Even without the electronic module (without electrical connection), there may be dangerous contact voltage at the motor contacts!

- Check for absence of voltage and cover or cordon off adjacent live parts!
- Close the shut-off devices upstream and downstream of the pump!

**DANGER****Potential danger of death due to electronic module not being installed!**

A life-threatening voltage may be present at the motor contacts! Normal operation of the pump is only permitted with the electronic module installed.

- Never connect or operate the pump without the electronic module mounted!

**NOTICE**

The magnets inside the motor do not pose a risk to persons with pace-makers provided that the motor is not opened and the rotor is not dismantled. The electronic module can be replaced without any risk.

Installation and dismantling (0.37 kW to 7.5 kW)**NOTICE**

For the installation, observe the torque specified for the respective thread type (see "Tightening torques" [► 34] table)!

1. To dismantle the electronic module, carry out steps 1 to 5 according to section "Changing the mechanical seal" [► 105].
2. Remove the screws (Fig. I, Item 4) and remove the electronic module from the motor.
3. Replace the O-ring (Fig. I, Item 31).
4. Press the electronic module into the new motor contacting and fasten with screws (Fig. I, Item 4).

Restore the pump's operational readiness: see section "Replacing the mechanical seal" [► 105]; steps 5 to 1!

**NOTICE**

The electronic module must be pressed on as far as possible when it is installed.

**NOTICE**

Disconnect the electronic module from the mains supply when performing another insulation test on site!

**NOTICE**

For the installation, observe the torque specified for the respective thread type (see “Tightening torques” [▶ 34] table)

1. To dismantle the electronic module, carry out steps 1 to 7 according to section “Replacing the mechanical seal” [▶ 105].
2. Loosen the screws of the electronic module and remove the upper part.
3. Disconnect and remove the mains connection cable and control cable.
4. Loosen the screws of the EMC protective plate (Fig. 113, Item 1) and remove the protective plate.

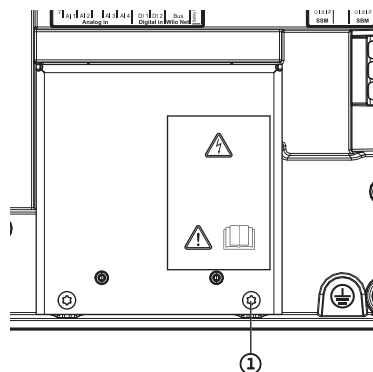

Fig. 113: EMC protective plate

5. Disconnect the motor connection cable (Fig. 114).

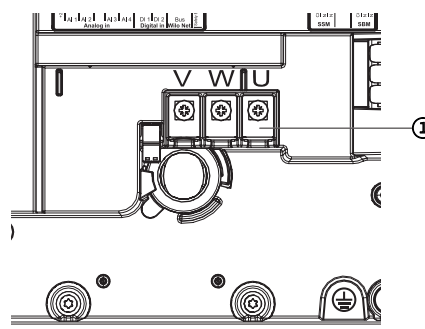

Fig. 114: Motor connection terminals V, W, U

6. Loosen the screws of the adapter plate on the bottom of the electronic module (Fig. 115, Item 1).

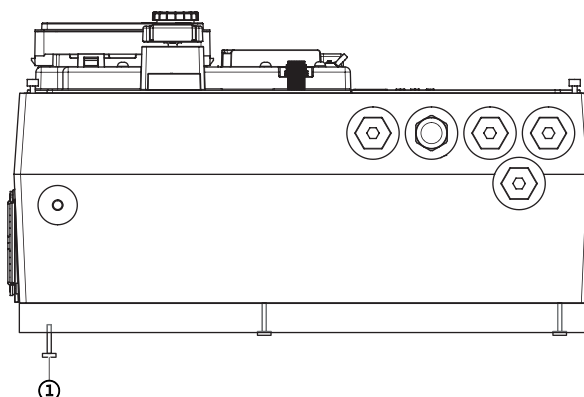

Fig. 115: Loosen adapter plate

7. Lift the electronic module off the adapter plate and set aside.
8. Carry out the installation of the electronic module in reverse order.

18.2.4 Module fan replacement

To dismantle the module, see section “Replacing the electronic module” and steps 1 to 5 in the section “Replacing the mechanical seal” [▶ 105].

Dismantling the module fan (0.37 kW to 7.5 kW):

1. Open the cover of the electronic module.

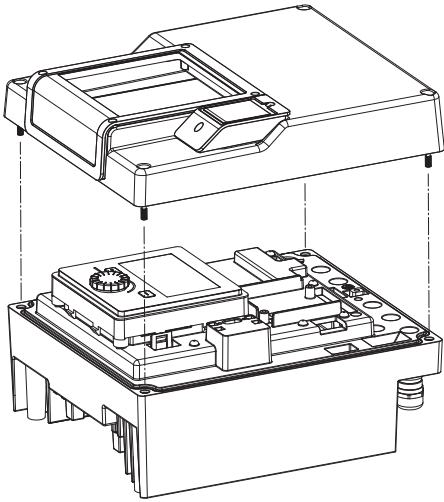

Fig. 116: Open the cover of the electronic module

2. Remove the connection cable of the module fan.

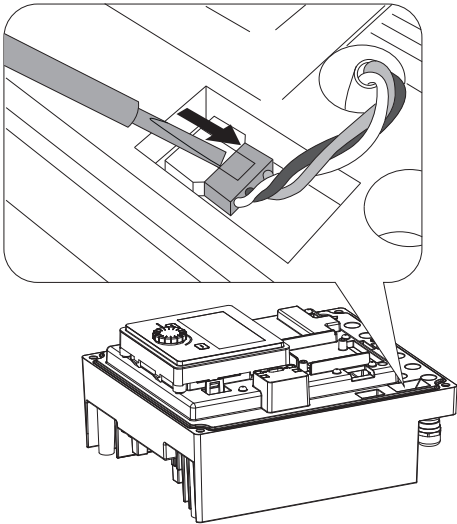

Fig. 117: Loosen the connection cable of the module fan

3. Loosen the screws of the module fan.

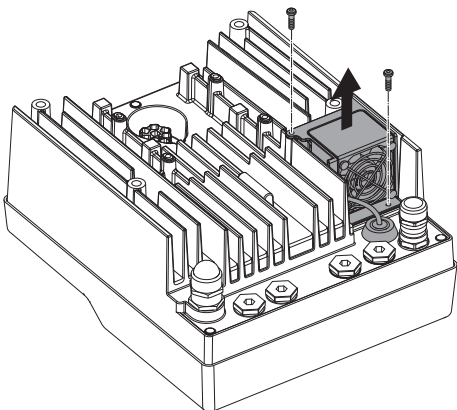

Fig. 118: Dismantling the module fan

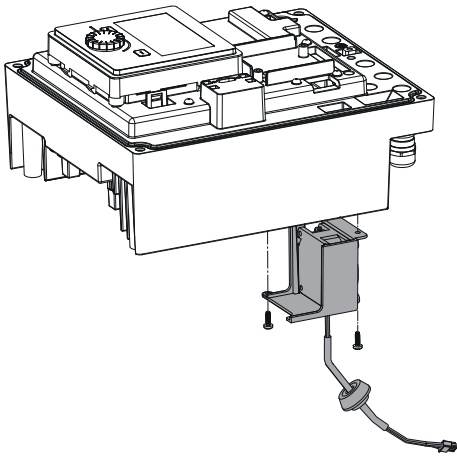

Fig. 119: Remove the module fan incl. cable and rubber sealing

4. Remove the module fan and loosen the cable with rubber sealing from the module lower part.

Installation of the new module fan (0.37 kW to 7.5 kW):

Install the new module fan in reverse order.

Dismantling the module fan (11 kW to 22 kW):

1. Open the cover of the electronic module.
2. Remove the connection cable of the module fan.

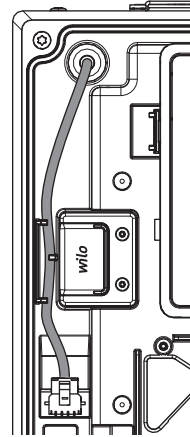

Fig. 120: Connection cable of the module fan

3. Loosen the screws of the module fan.

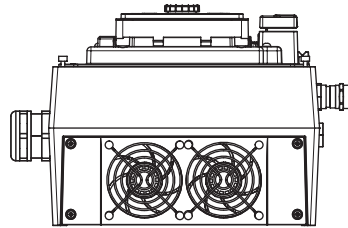

Fig. 121: Loosen the screws of the module fan

4. Remove the module fan and pull the cable out of the cable entry towards the inside of the module.

Installation of the new module fan (11 kW to 22 kW):

1. Install the new module fan in reverse order, as described above.

19 Spare parts

Obtain original spare parts only from a qualified installer or Wilo customer service. To avoid queries and order errors, please provide all pump, motor and drive rating plate data with every order. For pump rating plate, see Fig. 2, Item 1; for drive rating plate, see Fig. 2, Item 2; for motor rating plate (only for motor power 11 kW to 22 kW), see Fig. 3, Item 3.

CAUTION

Risk of property damage!

Trouble-free pump operation can only be guaranteed when original spare parts are used.

Use only original Wilo spare parts!

Information to be provided when ordering spare parts: Spare part numbers, spare part designations, all specifications from pump, motor and drive rating plate. This helps prevent return queries and incorrect orders.



NOTICE

For a list of genuine spare parts, see the Wilo spare parts documentation (www.wilo.com). The item numbers of the exploded view drawing (Fig. I to VII) are a guide and list the pump components.

These item numbers are **not** to be used for spare parts orders!

20 Disposal

20.1 Oils and lubricants

Operating fluids must be collected in suitable containers and disposed of in accordance with the locally applicable guidelines. Wipe up drips immediately!

20.2 Information on the collection of used electrical and electronic products

Proper disposal and appropriate recycling of this product avoids environmental damage and risks to personal health.



NOTICE

Disposal in domestic waste is prohibited!

In the European Union this symbol may be included on the product, the packaging or the accompanying documentation. It means that the electrical and electronic products in question must not be disposed of along with domestic waste.

Please note the following points to ensure proper handling, recycling and disposal of the used products in question:

- Hand over these products at designated, certified collection points only.
- Observe the locally applicable regulations!

Please consult your local municipality, the nearest waste disposal site, or the dealer who sold the product to you for information on proper disposal. Further recycling information at <http://www.wilo-recycling.com>.

Subject to change without prior notice!







wilo



Local contact at
www.wilo.com/contact

Pioneering for You

WILO SE
Wilopark 1
44263 Dortmund
Germany
T +49 (0)231 4102-0
T +49 (0)231 4102-7363
wilo@wilo.com
www.wilo.com