

Wilo-Drain LPC

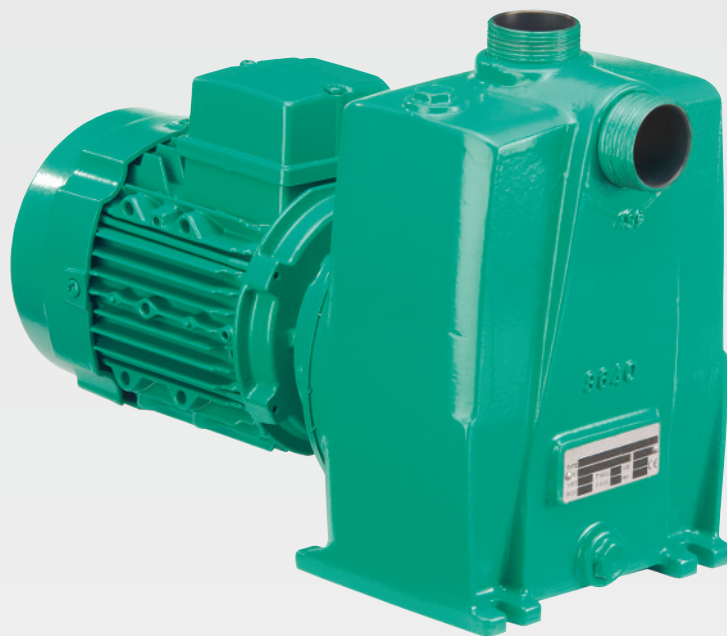

en Installation and operating instructions



Drain LPC
<https://qr.wilo.com/717>

Table of Contents

1	General	4
1.1	About these instructions	4
1.2	Copyright	4
1.3	Subject to change.....	4
1.4	Exclusion from warranty and liability.....	4
2	Safety	4
2.1	Safety signs, instructions, and text markups.....	4
2.2	Staff qualifications	5
2.3	Protective equipment for staff	5
2.4	Electrical work	5
2.5	Monitoring devices	6
2.6	Fluids hazardous to health	6
2.7	Use of lifting equipment.....	6
2.8	Installing/dismantling.....	6
2.9	During operation.....	6
2.10	Cleaning and disinfection	6
2.11	Operator responsibilities	7
3	Transportation and storage	7
3.1	Delivery.....	7
3.2	Transport.....	7
3.3	Storage	7
4	Application/use	7
4.1	Intended use	7
4.2	Improper use.....	8
5	Product description	8
5.1	Description.....	8
5.2	Material.....	8
5.3	Technical data	9
5.4	Type key.....	9
5.5	Scope of delivery.....	9
6	Installation and electrical connection	9
6.1	Operator responsibilities	9
6.2	Installation	9
6.3	Electrical connection	10
7	Commissioning	11
7.1	Staff qualifications	11
7.2	Operator responsibilities	11
7.3	Examine direction of rotation	11
7.4	Filling and venting the hydraulics.....	11
7.5	Before switch on the pump	12
7.6	Switching on and off	12
7.7	During operation.....	12
8	Shutdown/dismantling	12
8.1	Operator responsibilities	12
8.2	Shutdown.....	12
8.3	Removal.....	13
8.4	Cleaning	14
9	Maintenance	14
9.1	Operator responsibilities	14
9.2	Maintenance work	14
10	Faults, causes and remedies	15
11	Disposal	15
11.1	Information on the collection of used electrical and electronic products.....	15

1 General

- 1.1 About these instructions** These instructions are a part of the product. Obey the instructions for correct handling and use:
- Read the instructions carefully before all works.
 - Keep the instructions easily get access to.
 - Follow the product specifications.
 - Follow the markings on the product.
- 1.2 Copyright** WILO SE © 2025
The reproduction, distribution, and use of this document and the communication of its contents to others without express consent is prohibited. Infringement results in the obligation to pay for damages. All rights reserved.
- 1.3 Subject to change** Wilo reserves the right to change the listed data without prior notice and is not liable for technical inaccuracies and/or omissions. The illustrations vary from the original and are intended as a sample representation of the product.
- 1.4 Exclusion from warranty and liability** Wilo assumes no warranty or liability in these cases:
- Wrong configuration because the operator or the customer did not give enough or correct instructions
 - Non-compliance with these instructions
 - Incorrect use of the product
 - Incorrect storage or transport
 - Incorrect installation or dismantling
 - Not sufficient maintenance
 - Non-approved repairs
 - Not applicable installation location
 - Chemical, electrical or electrochemical causes
 - Wear of product components

2 Safety

- This section contains safety information for each phase of the product's lifecycle. Disregarding this information leads to:
- Danger to persons
 - Danger to the environment
 - Damage to property
 - Loss of claims for damages
- 2.1 Safety signs, instructions, and text markups** The safety instructions are structured as below:
- Danger to persons: signal word, safety symbol, text, and shaded grey.
 - Property damage: signal word and text.

Signal words

- **DANGER!**
Disregarding these instructions leads to death or serious injury.
- **WARNING!**
Disregarding these instructions leads to (serious) injury.
- **CAUTION!**
Disregarding these instructions leads to property damage or even a total loss.
- **NOTICE!**
Useful information for handling the product.

Text markups

- ✓ Precondition
- 1. Work step/list
 - ⇒ Notice/instructions
 - ▶ Result

Overview of safety symbols



Danger of death because of electric shock



Danger of death because of explosion



Warning – risk of (serious) injury



Warning – risk from hot surfaces



Obey the instructions.



Useful information

2.2 Staff qualifications

- The staff knows the local accident prevention regulations.
- The staff reads and understands these instructions.
- Electrical work: Only a qualified electrician must do the work.
Necessary knowledge: identification and prevention of electrical hazards
- Installation and dismantling work: Only a specialist in sewage facilities must do the work.
Necessary knowledge: pipework for wet and dry installation in sewage facilities, fastening of lifting slings and the use of slinging points
- Maintenance work: Only a specialist must do the work.
Necessary knowledge: assembly and disassembly skills, awareness of hot fluid hazards (up to 80 °C/176 °F)

This product is not for use by:

- Persons (including children) below the age of 16.
- Persons below the age of 21 without supervision from an expert.
- Persons with reduced physical, sensory, or mental abilities.

2.3 Protective equipment for staff

This protective equipment is the necessary basic equipment. Obey the factory regulations.

Protective equipment: transport, installation, and removal

- Safety shoes: Protection class S1 (uvex 1 sport S1)
- Safety gloves: 4X42C (uvex C500 wet)
- Safety helmet (EN 397): conforms to the standard and protects against lateral deformation
(If lifting accessories are used)

Protective equipment: maintenance

- Safety shoes: Protection class S1 (uvex 1 sport S1)
- Safety gloves: 4X42C (uvex C500 wet)
- Safety glasses: uvex skyguard NT
 - Marking of frame: W 166 34 F CE
 - Marking of eyeglass-lens: 0-0.0* W1 FKN CE
 * The safety class for filters is not necessary for this work.
- Safety helmet (EN 397): conforms to the standard and protects against lateral deformation
(If lifting accessories are used)

Protective equipment: cleaning work

- Safety gloves: 4X42C + Type A (uvex protector chemical NK2725B)
- Safety glasses: uvex skyguard NT
 - Marking of frame: W 166 34 F CE
 - Marking of eyeglass-lens: 0-0.0* W1 FKN CE
 * The safety class for filters is not necessary for this work.
- Respiratory mask: Half mask 3M series 6000 with filter 6055 A2

Article recommendations

The mentioned branded articles are non-binding suggestions. Equivalent products from other brands can also be used. The prerequisite is obeying the standards mentioned.

WILO SE accepts no liability for the articles mentioned regarding their conformity to the related standards.

2.4 Electrical work

- Do electrical work only by a qualified electrician.
- Obey the local regulations for the mains connection.
- Obey the specifications of the local energy supplier for the mains connection.

- Install protective earth conductor for mains connection. Obey local regulations.
- Earth the product.
- Follow the technical data on the rating plate and in these instructions.

2.5 Monitoring devices

Provide the monitoring devices listed below on-site:

Circuit breaker

- The type and switching characteristics of the circuit breakers must be compatible with the rated current of the connected product.
- Obey local regulations.

Motor protection switch

- The necessary basic equipment is a thermal relay/motor protection switch with temperature compensation, differential triggering, and a reactivation lock. Obey local regulations.
- Power supply systems not stable: If necessary, install more monitoring devices for over-voltage, undervoltage, or phase failure.

Residual-current device (RCD)

- If persons can touch the device and conductive fluids, install a residual-current device (RCD).
- Obey the regulations of the local energy supplier.

2.6 Fluids hazardous to health

The pump is designed to pump fluids with a fluid temperature of up to 80 °C (176 °F). There is a danger because of burns to pipework and leaks.

There can also be hazardous germs in stagnant water. There is a danger of bacterial infection.

- Wear protective equipment. Obey the factory regulations.
- Clean and disinfect the product thoroughly after removal.

2.7 Use of lifting equipment

If a lifting equipment (crane, chain hoist ...) is used, obey these points:

- Wear a safety helmet according to EN 397.
- Obey local regulations for the use of the lifting equipment.
- The operator is responsible for the technically correct use of the lifting equipment.
- **Lifting accessory**
 - Only use lifting accessories that function correctly.
 - Do not overload the lifting accessory.
 - Make sure that the lifting accessory is stable.
- **Lifting slings**
 - Use only legally permitted lifting slings.
 - Use lifting slings based on local conditions (weather, slinging point, load ...).
 - Always attach the lifting slings to the slinging points.
- **Lifting operation**
 - Do not jam the product when lifting and lowering.
 - Do not overload the lifting accessory.
 - If necessary (e.g., view blocked ...), help from a second person is a must.
 - Do **not stay** below suspended loads. Do **not move** suspended loads over workplaces where persons are on-site.
 - Stay away from the swivel area.
 - If it is no longer safe to work because of the weather conditions, stop working immediately.

2.8 Installing/dismantling

- Obey local regulations and laws on accident prevention and work safety on-site.
- Make sure that the product is disconnected from the mains connection. Prevent the product from unwanted switching on.
- Ventilate closed rooms.
- Do not work alone in closed rooms. Only do this work with a second person.
- Toxic or asphyxiating gases can collect in closed rooms or buildings. Wear protective equipment (e.g., gas detector). Obey the factory regulations.

2.9 During operation

- The pump pumps fluids with a fluid temperature of up to 80 °C (176 °F).
 - Mark and close the working area.
 - Keep not permitted persons away from the working area.
 - There is a risk of skin burns from touching the pipework, leaks, and the pump housing.
- Depending on the plant process, the on-site control starts or stops the product. The product can start automatically after a blackout.

2.10 Cleaning and disinfection

- Wear protective equipment. Obey the factory regulations.
- Use a disinfectant. Follow the manufacturer's instructions:
 - Wear the given protective equipment. If you are not sure, contact your supervisor.

2.11 Operator responsibilities

- Give the staff the necessary information about the disinfectant and its correct use.
- Supply these instructions in the language which the staff can read and understand.
- Make sure that staff are trained to do the set tasks.
- Supply protective equipment. Make sure that staff wears protective equipment.
- Make sure that attached safety and warning signs are clearly readable.
- Tell staff how the system operates.
- Fit hazardous components in the system with an on-site guard.
- Mark and close the working area.

3 Transportation and storage

3.1 Delivery

- Immediately examine the shipment for defects (damage, completeness ...).
- Write all defects on the freight documentation.
- Tell the manufacturer about the defects on the day of receiving the shipment.
- Subsequent told claims can no longer be asserted.

3.2 Transport

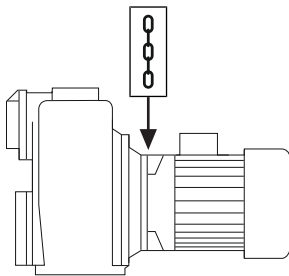

Fig. 1: Slinging point

- Wear protective equipment. Obey the factory regulations.
- Use only a polyester webbing sling as a lifting sling.
- Put the polyester webbing sling around the pump housing (slinging point) as a sling.
- Make sure that the lifting slings are tight.
- Prevent the motor from water ingress. Do not immerse the pump in the fluid.
- To prevent damage to the pump during the move, only remove the outer packaging at the installation site.
- Use leak-proof packaging for used pumps, e.g., rip-proof plastic bags.

3.3 Storage

CAUTION

Property damage through water ingress in the motor!

Water in the motor leads to a total loss of the pump.

- Do not immerse the pump in the fluid.
-

- Drain the hydraulics housing.
- Do not keep the pump outdoors. If it is necessary to keep the pump outdoors, follow these points:
 - Watertight and protective packaging
 - No ground or flood water
 - The temperature limits also apply to outdoor storage.
- Maximum storage time: one year.
If it is necessary to keep the pump in stock for more than one year, contact customer service.
- Storage temperatures:
 - Maximum: -15 ... +60 °C (5 ... 140 °F), max. humidity: 90 %, non-condensing.
 - Recommended: 5 ... 25 °C (41 ... 77 °F), relative humidity: 40 ... 50 %.
 - High temperatures can damage the pump. Keep the pump out of the sun.
- Do not keep the pump where welding work is in progress. The gases or radiation can damage elastomer parts and coatings.
- Tightly seal the suction port and the discharge port.

4 Application/use

4.1 Intended use

For the pumping in commercial areas of the fluids listed:

- Wastewater (with small amounts of sand and gravel)
- Industrial water

For the use in the listed applications:

- Drainage of construction sites
- Drainage of soakaway and ponds
- Irrigation and sprinkling of gardens and parks

4.2 Improper use



DANGER

Explosion hazard when pumping explosive fluids!

The pump is not designed to pump highly flammable and explosive fluids. There is a danger of death through explosion.

- Do not pump highly flammable or explosive fluids (e.g., gasoline, kerosene, ...).

Do not use the pump for the fluids listed below:

- Untreated sewage
- Sewage with faeces
- Drinking water
- Fluids with hard ingredients (e.g., stones, wood, metal ...)
- Fluids with a high quantity of abrasive ingredients (e.g., sand, gravel ...)
- Viscous fluids (e.g., oil and grease)
- Sea water

5 Product description

5.1 Description

Self-priming, non-submersible pump for stationary installation in a dry environment.

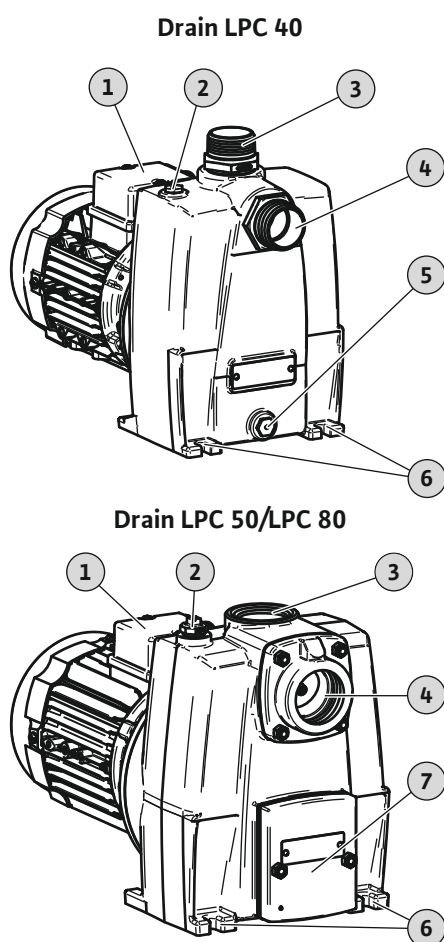

1	Electrical connection box
2	Opening for filling and venting hydraulics
3	Discharge port
4	Suction port
5	Drain plug
6	Fastening strap
7	Cover of the inspection opening

Drain LPC 40

Self-priming drainage pump in monobloc design with a multi-channel impeller, horizontal suction port, and vertical discharge port. Threaded (male thread) suction and discharge ports. Pump housing made of aluminium, impeller made of grey cast iron. Standard three-phase AC motor without connection cable. Motor housing made of aluminium. Mounted through a low-vibration baseplate.

Drain LPC 50/LPC 80

Self-priming drainage pump in monobloc design with a multi-channel impeller, horizontal suction port, and vertical discharge port. Threaded (female thread) suction and discharge ports, suction port fitted with non-return valve. Pump housing with an inspection opening for removal of blockages. Pump housing and impeller made of grey cast iron. Standard three-phase AC motor without connection cable. Motor housing made of aluminium. Mounted through a low-vibration baseplate.

Fig. 2: Product overview

5.2 Material

	Drain LPC 40	Drain LPC 50	Drain LPC 80
Hydraulics housing	AlSi	EN-GJL-250 (ASTM A48 Class 35b)	EN-GJL-250 (ASTM A48 Class 35b)
Impeller	EN-GJL-250 (ASTM A48 Class 35b)	EN-GJL-250 (ASTM A48 Class 35b)	EN-GJL-250 (ASTM A48 Class 35b)
Shaft	1.4104 (AISI 430F)	1.4104 (AISI 430F)	1.4104 (AISI 430F)

	Drain LPC 40	Drain LPC 50	Drain LPC 80
Mechanical seal	C/Al	C/Al	SiC/SiC
Static seal	NBR	NBR	NBR
Motor housing	Al	Al	Al

5.3 Technical data

	Drain LPC 40	Drain LPC 50	Drain LPC 80
Discharge port	R 1½	G 2 (ISO 228)	G 3 (ISO 228)
Suction port	R 1½	G 2 (ISO 228)	G 3 (ISO 228)
Free ball passage	6 mm (0.24 in)	6 mm (0.24 in)	12 mm (0.47 in)
Max. suction height	7.5 m (24.5 ft)	7.5 m (24.5 ft)	7.5 m (24.5 ft)
Mains connection	3~230/400 V, 50 Hz	3~230/400 V, 50 Hz	3~230/400 V, 50 Hz; 3~400/690 V, 50 Hz
Operation mode	S1	S1	S1
Fluid temperature	3 ... 80 °C (37 ... 176 °F)	3 ... 80 °C (37 ... 176 °F)	3 ... 80 °C (37 ... 176 °F)
Ambient temperature	3 ... 40 °C (37 ... 104 °F)	3 ... 40 °C (37 ... 104 °F)	3 ... 40 °C (37 ... 104 °F)
Max. switching frequency /h	10/h	10/h	10/h
IP rating	IP55	IP55	IP55

NOTICE! See the rating plate for further technical data.

5.4 Type key

Example:	Wilo-Drain LPC 50/25
Drain	Drainage pump
LP	Self-priming pump
C	Hydraulics made of grey cast iron
50	Nominal size of discharge port
25	Max. delivery head in m

5.5 Scope of delivery

- Pump
- Installation and operating instructions

6 Installation and electrical connection

6.1 Operator responsibilities

- Obey local accident prevention and safety regulations.
- Supply protective equipment. Make sure that staff wears protective equipment.
- Structural components and foundations must be sufficiently stable for the device to be fixed in a safe and functional manner. The operator is responsible to supply correct structural component/foundation.
- Obey local regulations for the installation work.
- Obey regulations for working below suspended loads when using lifting accessories.

6.2 Installation



DANGER

Danger through alone working!

Working in chambers, narrow rooms, and in areas with a risk of falling can be dangerous. Do not work alone.

- Only do this work with a second person.

- Wear protective equipment. Obey the factory regulations.
- Prepare the installation site:
 - Flat and hard surface
 - Clean, free of coarse solids
 - Dry
 - Frost free
 - Sufficiently lit
- Do not install damaged products.
- Toxic or asphyxiating gases can collect during work.
- Keep the area properly ventilated.
- If toxic or asphyxiating gases collect, go out of the workplace immediately.

6.2.1 Stationary dry installation

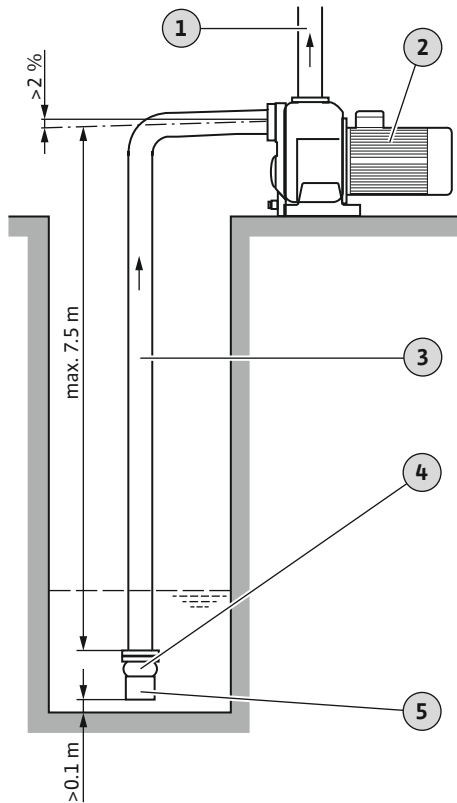

Fig. 3: Stationary dry installation

1	Discharge line
2	Self-priming pump
3	Suction pipe
4	Foot valve (Only necessary for Drain LPC 40. Drain LPC 50 and LPC 80 have an integrated non-return valve at the suction port.)
5	Suction filter

The pump is dry-installed and the suction and discharge pipes are permanently connected. The pump primes the fluid from the tank and pumps it into the discharge line. Obey these points for installation:

- Fasten the pump on the bottom.
 - Seal the pipe connections with Teflon band.
 - Discharge pipe:
 - Make sure that the discharge line is self-supporting and not supported by the pump.
 - The diameter of the discharge line is the same or larger than the diameter of the discharge port.
 - Make sure that the discharge line is installed frost-proof.
 - Do not install the discharge line above or near the motor. The motor is not submersible or watertight. Water ingress (condensation water, leakage) leads to a total loss of the motor.
 - Install all necessary fittings according to the local regulations (gate valve, non-return valve).
 - Suction pipe:
 - To prevent air bubbles in the suction pipe, install the suction pipe with a 2 % slope in the direction of the tank/basin.
 - If possible, use a solid pipe for the suction pipe.
 - Keep the suction pipe as short as possible.
 - The diameter of the suction pipe is the same or larger than the diameter of the suction port. A decrease in the suction pipe leads to pressure losses or overloading of the pump.
 - To prevent clogging of the suction pipe, install a suction filter.
 - **Only Drain LPC 40:** install a foot valve.
- The Drain LPC 50 and LPC 80 have an integrated non-return valve in the suction port.

6.3 Electrical connection



DANGER

Danger of death through electrical shock!

Incorrect behaviour during electrical work results in death by electric shock.

- Only a qualified electrician must do the electrical work.
- Obey local regulations.

6.3.1 Mains connection

- Make sure that the mains connection is compatible with the voltage (U) and frequency (f) data on the rating plate.
- Clockwise rotating field available.
- Install monitoring devices (circuit breaker, motor protection switch). Obey local regulations.
- Install protective earth conductor for mains connection. Obey local regulations.
- Earth the product.
- Make sure that all connection cables are laid properly. Prevent the connection cables from posing a risk (i.e. tripping, damage during operation). Examine if the cable cross-section and the cable length are sufficient for the selected installation type.

Do not connect the pump in the conditions listed below:

- A start-up control device is used.
Do not connect the pump to a frequency converter or a soft starter. The pump is not designed for such operation.
- There is a potentially explosive atmosphere. The pump has no Ex approval.

6.3.2 Motor connection: three-phase AC design



DANGER

Danger of death through electrical shock!

Incorrect behaviour during electrical work results in death by electric shock.

- Only a qualified electrician must do the electrical work.
- Obey local regulations.

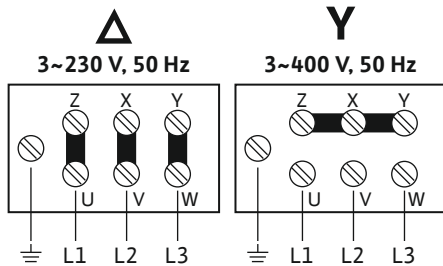

Fig. 4: Motor connection

Δ	Motor connection: delta design
Y	Motor connection: star design

- ✓ Monitoring devices installed.
 - ✓ Protective earth conductor installed.
 - ✓ Mains connection with a clockwise rotating field.
 - ✓ Connection cable supplied on-site. Cable type and cross-section depend on the cable length and type of installation.
1. Examine the rotating field with a rotary field tester. **Do not use** the pump at a counter-clockwise rotating field.
 2. Open the terminal box.
 3. Insert the connection cable through the cable inlet in the terminal box. The cable inlet must be rated IP55.
 4. Connect the connection cable to the terminals.
 5. Close the terminal box.
 - ▶ The pump is connected.

6.3.3 Settings for the motor protection switch

Set the motor protection depending on the selected activation type.

Direct activation

- At **full load**, set the motor protection switch to the rated current (see rating plate).
- At **partial load**, it is recommended to set the motor protection switch 5% above the measured current at the duty point.

7 Commissioning



NOTICE

Automatic switching on after power blackout

A switchgear controlled the product. The product is automatically switched on and off depending on the application.

The product can start automatically after a power blackout.

7.1 Staff qualifications

- Operation/control: The staff knows how to operate the system.

7.2 Operator responsibilities

- Supply these instructions in the language which the staff can read and understand.
- Make sure that staff are trained to do the set tasks.
- Make sure that all system-side safety devices and emergency cut-outs are active and working correctly.
- Make sure that the pump is applicable for the given operating conditions.
- Measure the noise level in operating conditions. For a noise level of 85 dB(A) or higher, wear hearing protection. Mark the working area.

7.3 Examine direction of rotation

For a correct direction of rotation, make sure that the mains connection has a clockwise rotating field. The pump is not designed to operate on a counter-clockwise rotating field. Use a rotating field tester to examine the mains connection's rotating field. If necessary, change two phases on the mains connection.

7.4 Filling and venting the hydraulics



WARNING

Risk of injury from a pressurised and hot water jet!

Do not unscrew the drain plug while the pump is running or starting. The fluid will shoot out of the filling and venting opening.

- Switch off the pump before filling and venting the hydraulics.
- Prevent the on-site control from unapproved start-up.

Before switching on the pump, make sure that the hydraulics is filled with water, and properly vented. Follow the steps below (Description [► 8]).

Drain LPC 40

✓ The Drain LPC 40 does not have a non-return valve in the suction port. Make sure that a foot valve is fitted to the suction pipe. Without this foot valve, filling and venting of the hydraulics is not possible

1. Unscrew the plug from the filling/venting opening.
2. Slowly fill the hydraulics **and the suction pipe** with water up to the filling/venting opening.
3. Screw the plug into the filling/venting opening.

Drain LPC 50/LPC 80

1. Unscrew the plug from the filling/venting opening.
2. Slowly fill the hydraulics with water up to the filling/venting opening.
3. Screw the plug into the filling/venting opening.

7.5 Before switch on the pump

Examine these points before starting the pump:

- Electrical connection complies with local regulations?
- Connection cable safely laid (preventing from tripping points and damage)?
- Level control operates correctly?
- Level control switching points are correctly set?
- Operating conditions kept (fluid temperature, suction depth)?
- Hydraulics filled and vented?
- Suction filter is installed?
- Air vent valve is installed in the discharge pipe?
- Shut-off valve in the discharge pipe is open?
- **For Drain LPC 40 only:** foot valve is installed on the suction pipe?

7.6 Switching on and off

The pump switches On and Off by an on-site control (on/off switch, switchgear).

NOTICE! The suction procedure can be from two seconds to five minutes.

7.7 During operation



WARNING

Risk of burns from hot surfaces and fluids!

The pipework, the pump housing, and the fluid can heat up to 80 °C (176 °F). There is a risk of skin burns if components are touched.

- Mark and close the working area.
- Keep not permitted persons away from the working area.
- Cool down the pump to ambient temperature after switching off.

While it is in use, examine these points:

- Pump prevented against flooding and water ingress.
The motor is not submersible or watertight. Water ingress (condensation water, leakage) leads to a total loss of the motor.
- Level control works correctly.
- Pump does not run dry.
Dry running leads to a total loss. Switch off the pump when the minimum water level is reached.
- If the product malfunctions, switch off the product immediately.
- Open all shut-off valves in the inlet and discharge pipe.
- The noise level depends on different factors, e.g. fixation type, operating point, etc.
Measure the noise level during operation. If the noise level is above 85 dB(A), wear hearing protection and mark the working area.

8 Shutdown/dismantling

8.1 Operator responsibilities

- Obey local accident prevention and safety regulations.
- Supply protective equipment. Make sure that staff wears protective equipment.
- Do not work alone in closed rooms. Only do this work with a second person.
- Ventilate closed rooms.
- Toxic or asphyxiating gases can collect in closed rooms or buildings. Wear protective equipment (e.g., gas detector). Obey the factory regulations.

8.2 Shutdown

Shutdown means that the pump is deactivated but kept installed. In this condition, the pump is ready for use and can be reactivated at any time.

- ✓ Make sure that the installation site is dry and frost-free, with a minimum ambient temperature of +3 °C (+37 °F).
 - ✓ Run the pump for 5 minutes each month to prevent encrustations and clogging. **NO-TICE! Only start the pump at usual operating conditions.**
1. Switch off the pump at the on-site control.
 2. Prevent the on-site control from unapproved start-up (e.g., lock the mains switch).

8.3 Removal



DANGER

Danger of death through electrical shock!

Incorrect behaviour during electrical work results in death by electric shock.

- Only a qualified electrician must do the electrical work.
- Obey local regulations.



DANGER

Danger through alone working!

Working in chambers, narrow rooms, and in areas with a risk of falling can be dangerous. Do not work alone.

- Only do this work with a second person.



WARNING

Risk of burns from hot surfaces and fluids!

The pipework, the pump housing, and the fluid can heat up to 80 °C (176 °F). There is a risk of skin burns if components are touched.

- Mark and close the working area.
- Keep not permitted persons away from the working area.
- Cool down the pump to ambient temperature after switching off.

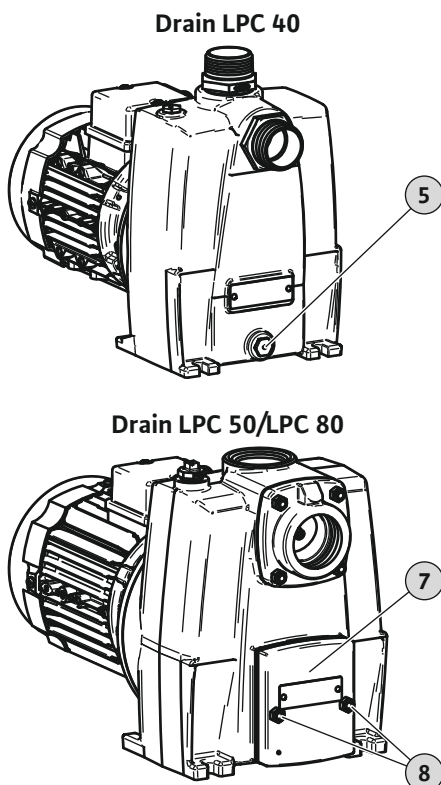

5	Drain plug
7	Cover of the inspection opening
8	Cover fixation

- Wear protective equipment. Obey the factory regulations.
- Clean the product thoroughly.
- There can be hazardous germs in stagnant water.
 - There is a danger of bacterial infection.
 - Disinfect the product.

After shutting down, remove the pump from the installation site if necessary. To remove the pump, follow these two steps:

- Drain the hydraulics
- Remove the pump

For Drain LPC 40: drain the hydraulics

- ✓ Make sure that the pump is shut down.
 - ✓ Make sure that the pump has cooled to ambient temperature.
1. Close the gate valves in the suction pipe and discharge pipe.
 2. Disconnect the pump from the mains.
 3. Unscrew the drain plug. The fluid drains out.
 4. Screw the drain plug in again.

For Drain LPC 50 and LPC 80: drain the hydraulics

- ✓ Make sure that the pump is shut down.
 - ✓ Make sure that the pump has cooled to ambient temperature.
1. Close the gate valves in the suction pipe and discharge pipe.
 2. Disconnect the pump from the mains.
 3. Unscrew the two screws on the inspection opening.
 4. Remove the cover from the inspection opening. The fluid drains out.

Fig. 5: Drain the hydraulics

5. Clean the inspection opening, cover, and the seal.
6. Install the cover and seal against the inspection opening.
7. Fasten the cover with the two screws.

Remove the pump

Before removing the pump, examine these points:

- Pump is shut down.
- Pump has cooled to ambient temperature.
- Pump is disconnected from the mains.
- Hydraulics have been drained.

8.4 Cleaning

- Wear protective equipment. Obey the factory regulations.
- The motor and the terminal box are **not watertight**. Use only a moist cloth for cleaning.
- Flush the hydraulics with clear water.
- Drain the cleaning water to the sewer.
- If necessary, use a disinfectant.
 - Wear the given protective equipment. If you are not sure, contact your supervisor.
 - Give all staff the necessary information about the disinfectant and its correct use.

9 Maintenance

9.1 Operator responsibilities

- Supply protective equipment. Make sure that staff wears protective equipment.
- Only use original parts from the manufacturer. Using non-original parts releases the manufacturer from any liability.
- Supply the necessary tools.
- Write all maintenance tasks in an inspection protocol.

9.2 Maintenance work

- Only do maintenance tasks listed in this instruction.
- Make sure that the product is disconnected from the mains connection. Prevent the product from unwanted switching on.
- Immediately clean up and remove leaked liquids (fluid, operating fluid). Obey local regulations to dispose of these liquids.

9.2.1 Clogged hydraulics cleaning (only Drain LPC 50 and LPC 80)



WARNING

Risk of burns from hot surfaces and fluids!

The pipework, the pump housing, and the fluid can heat up to 80 °C (176 °F). There is a risk of skin burns if components are touched.

- Mark and close the working area.
- Keep not permitted persons away from the working area.
- Cool down the pump to ambient temperature after switching off.

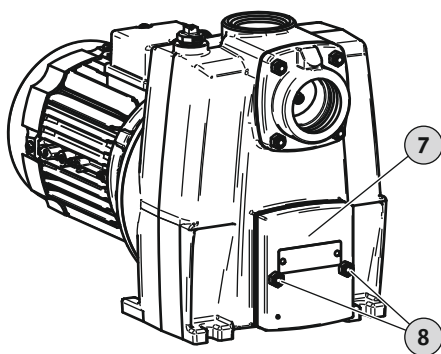

Fig. 6: Cleaning clogged hydraulics

7	Cover of the inspection opening
8	Cover fixation

- ✓ Wear protective equipment. Obey the factory regulations.
 - ✓ Make sure that the pump is shut down.
 - ✓ Prevent the pump from unapproved start-up.
 - ✓ Make sure that the pump has cooled to ambient temperature.
1. Close the gate valves in the suction pipe and discharge pipe.
 2. Unscrew the two screws on the inspection opening.
 3. Remove the cover from the inspection opening. The fluid drains out.
 4. Remove the insert from the inspection opening.
 5. Remove dirt and blockages from the hydraulics.
 6. Clean the inspection opening, insert, cover, and the seal.
 7. Install the insert in the inspection opening.
 8. Install the cover and seal against the inspection opening.
 9. Fasten the cover with the two screws.

9.2.2 General overhaul

A general overhaul is necessary after 15,000 hours of operation. During a general overhaul, the motor bearings, shaft seals, O-rings and connecting cables are checked for wear and damage. Damaged components are replaced with original parts. This maintenance is necessary to keep correct operation. Contact customer service for maintenance.

10 Faults, causes and remedies

Cause	Remedy
Fault: The pump is not priming.	
Incorrect commissioning procedure.	See Filling and venting the hydraulics [► 11]
The suction procedure can be from two seconds to five minutes.	
Air intake into the suction line.	Examine the pipework for leaks.
Suction filter clogged.	Clean the suction filter
Integrated non-return valve in the suction port blocked (only LPC 50 and LPC 80).	Remove suction pipe and clean the non-return valve.
Suction height is too high.	Max. suction height is 7.5 m. Examine the operating conditions.
Fault: No or not sufficient flow rate	
Suction filter clogged.	Clean the suction filter
Direction of rotation incorrect (counter-clockwise rotating field).	Examine mains connection. Clockwise rotating field necessary.
Gate valves are closed.	Open the gate valves in the suction pipe and discharge pipe.
Wear and tear at the hydraulics.	Contact customer service.
Fault: Motor protection switch tripped or the motor overheated.	
Mains connection incorrect.	Examine the mains connection. Contact an electrician.
Motor circuit breaker incorrectly set	Examine the setup.
Phase failure.	Examine the mains connection. Contact an electrician.
Wear and tear at the hydraulics.	Contact customer service.

11 Disposal

11.1 Information on the collection of used electrical and electronic products

To prevent damage to the environment and human health, make sure to dispose of and recycle this product correctly.



NOTICE

Do not dispose of the product in domestic waste!

This symbol means do not dispose of the product in domestic waste. The symbol is applied on the product or on the packaging.

Follow these points for a correct disposal of the product:

- Only return the product to a designated and permitted collection point.
- Obey local regulations.

Consult your local municipality, the nearest waste disposal site, or your retailer for a correct disposal. See for more <http://www.wilo-recycling.com> information about recycling.









wilo



Local contact at
www.wilo.com/contact

Pioneering for You

WILO SE
Wilopark 1
44263 Dortmund
Germany
T +49 (0)231 4102-0
T +49 (0)231 4102-7363
wilo@wilo.com
www.wilo.com