

Pioneering for You

**wilo**



Single and double pump lifting units  
with macerator

# Wilo-DrainLift SANI CUT

## Simply secure in sewage transport



**NEW**



The Wilo-DrainLift SANI CUT is a compact sewage lifting unit with macerator hydraulics in accordance with DIN EN12050-1. This makes it the optimum choice for building drainage.

Wilo macerator technology, already tried and tested in water management, reliably shreds all solids and pumps the sewage into the sewer network, particularly in cases where this cannot be discharged directly into the sewer system via a natural downward slope.

The Wilo-DrainLift SANI CUT macerator lifting units are particularly well-suited to cramped installation situations, large delivery heads or small discharge pipelines <DN 80.

Freely selectable inlets and a space-saving design ensure the Wilo-DrainLift SANI CUT offers high installation flexibility and also allows it to fit in concealed walls. This makes it ideal for replacing older, existing lifting units.

The user-friendly design with transparent inspection opening also makes maintenance for the Wilo-DrainLift SANI CUT particularly simple.

# Wilo-DrainLift SANI CUT

## The lifting unit with up to 5 connections



Up to 5 connections possible:  
Wash basins, shower, bathtub,  
toilet and bidet

- 1 Tank cover with viewing panel for visual inspection
- 2 Freely selectable inlet areas DN 100 to DN 150
- 3 Motor housing made of corrosion-resistant stainless steel with double sealing
- 4 Discharge port DN 32/40
- 5 Non-return valve
- 6 Optimised hydraulics/macerator combination
- 7 Compact tank with large switching volume
- 8 Connection for 50 mm manual drain

### YOUR BENEFITS

- Simple installation and easiest transport thanks to light, space-saving compact design
- Large switching volume, pump with radial macerator with double shear effect, thermal motor protection and mains-independent alarm ensure operational reliability
- Optimised hydraulics/macerator combination for extensive coverage of delivery heads with the lowest power requirements for domestic electrical installations
- Low overall installation costs due to use of smallest possible pipes
- Corrosion-free design with engineering plastics and stainless steel for high reliability
- Freely selectable connections for maximum installation flexibility
- Transparent tank cover and cleaning opening for easy maintenance

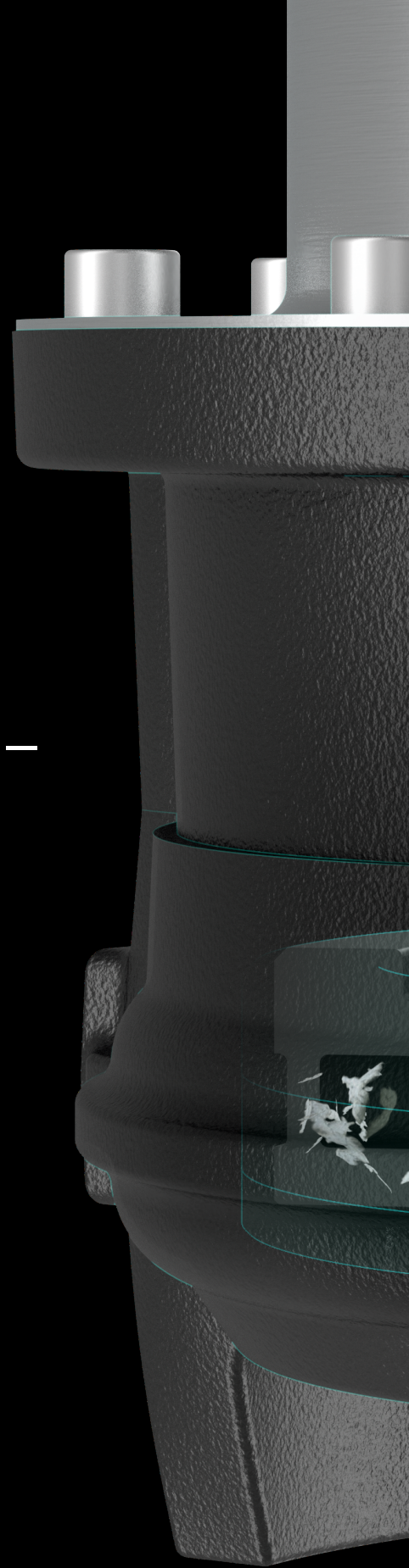

**Simply reliable.**

Impeller with double shear effect –  
exclusively from Wilo

The Wilo-DrainLift SANI CUT reliably shreds solids  
with its double shear effect.

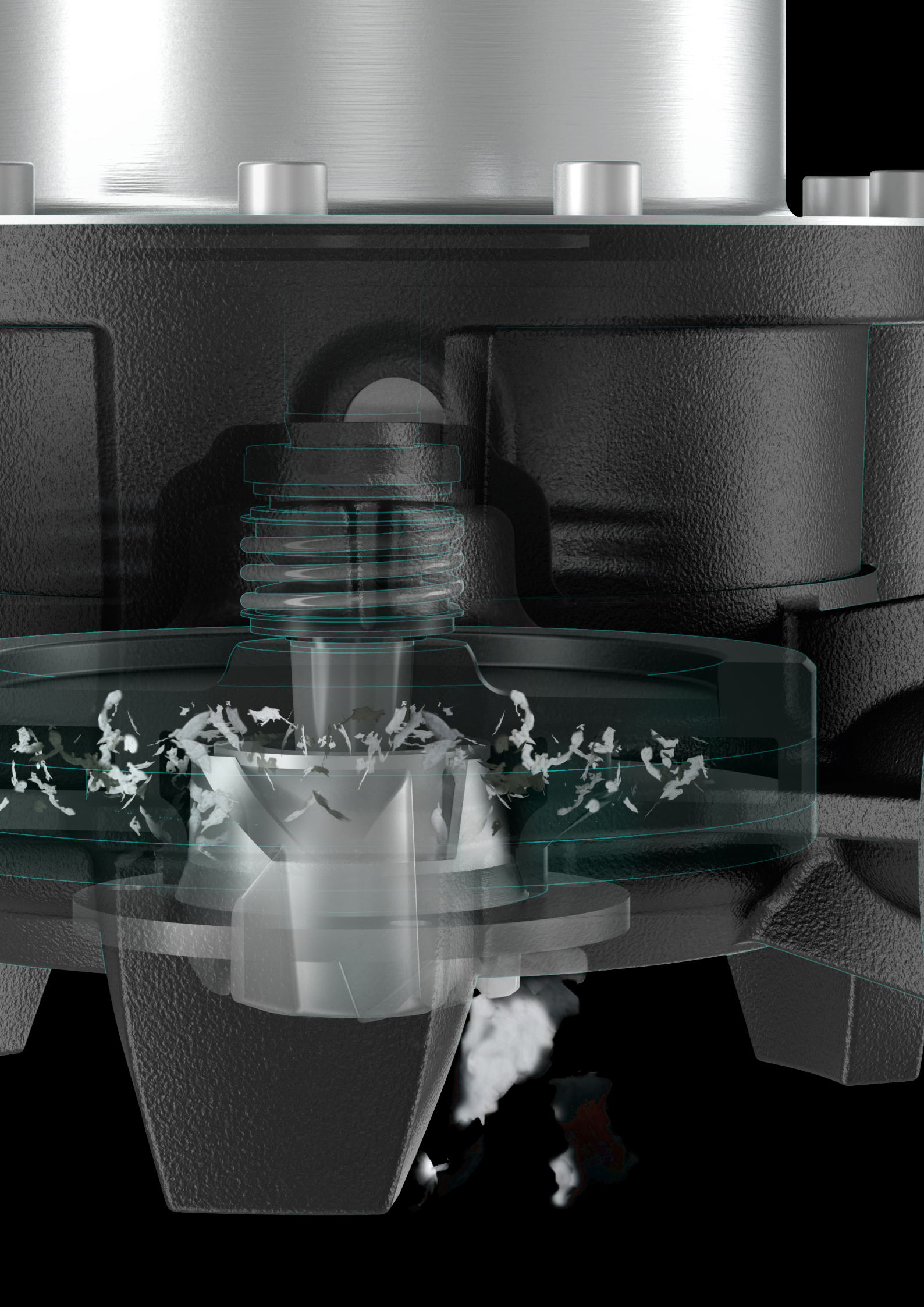

# The Wilo-DrainLift SANI CUT product family



**Wilo-DrainLift SANI CUT-S**

The smallest single-pump faeces lifting unit for detached and semi-detached houses



**Wilo-DrainLift SANI CUT-M**

The single-pump faeces lifting unit for detached and semi-detached houses



**Wilo-DrainLift SANI CUT-L**

The double-pump faeces lifting unit for multi-residential buildings and commercial buildings

## TYPE KEY

Example: **DrainLift SANI CUT-S.20M/1**

- DrainLift** Product family
- SANI CUT** Sewage lifting unit with macerator
- S** Size
- 20** Max. delivery head
- M** Mains connection:
  - M = 1~
  - T = 3~
- 1** Version for motor and switchgear:
  - 1 = operating mode: S3, switchgear: Control MS-L

Switchgear included in the scope of delivery

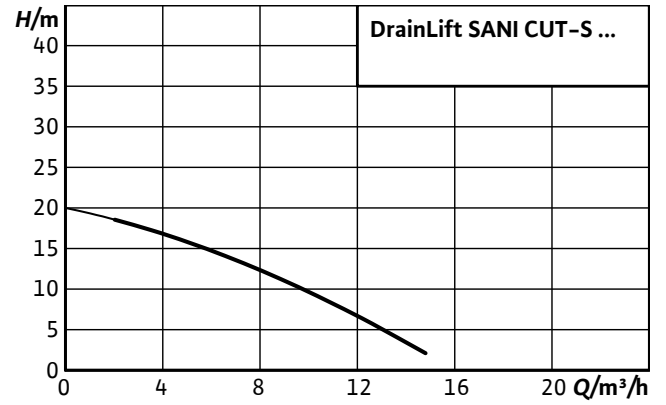

## TECHNICAL DATA

Type Wilo-DrainLift SANI CUT-S	Mains connection	Rated power	Wilo-Control MS-L switchgear	Mains plug	Article number
	V	kW			
20M/1	230	0.75	1x8 A-MDOL-C22-S	Shockproof plug	6095513
20T/1	400	0.75	1x4 kW-T4-DOL-S	CEE	6095514

CEE 16 A, 3P + N + PE, 6 h

## DIMENSION DRAWING

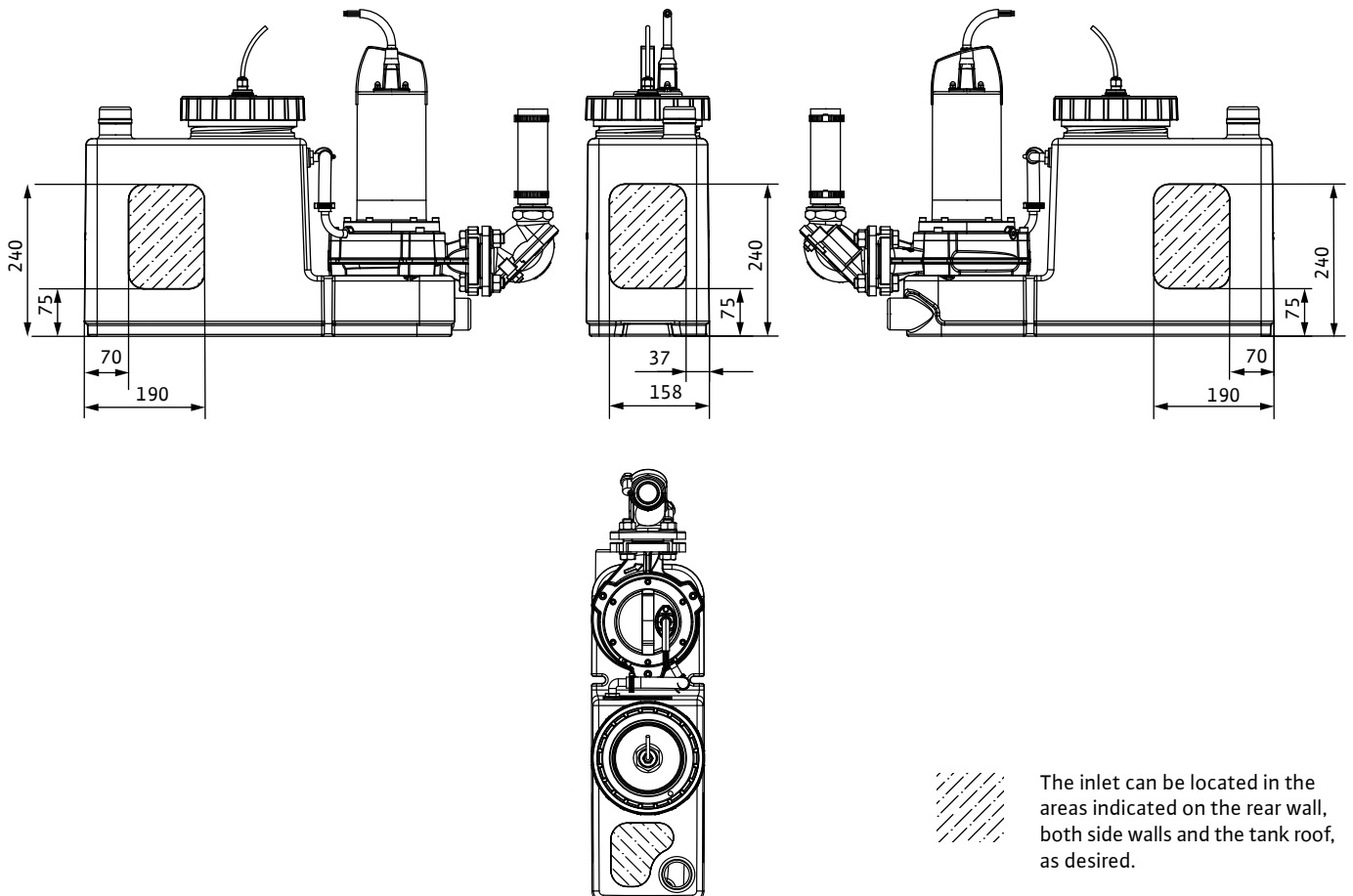

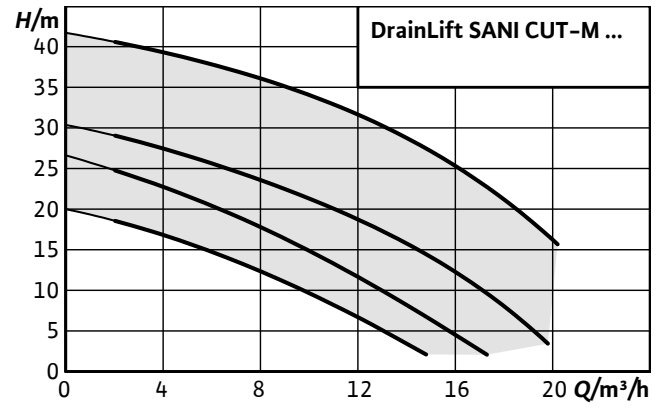

## TECHNICAL DATA

Type Wilo-DrainLift SANI CUT-M	Mains connection	Rated power	Wilo-Control MS-L switchgear	Mains plug	Article number
	V	kW			
20M/1	230	0.75	1x8 A-MDOL-C22-LS	Shockproof plug	6095520
20T/1	400	0.75	1x8 A-T4-DOL-LS	CEE	6095521
27M/1	230	1.1	1x12 A-MDOL-C35-LS	Shockproof plug	6095522
27T/1	400	1.1	1x8 A-T4-DOL-LS	CEE	6095523
30M/1	230	1.5	1x12 A-MDOL-C35-LS	Shockproof plug	6095524
30T/1	400	1.5	1x8 A-T4-DOL-LS	CEE	6095525
42T/1	400	2.5	1x8 A-T4-DOL-LS	CEE	6095526

CEE 16 A, 3P + N + PE, 6 h

## DIMENSION DRAWING

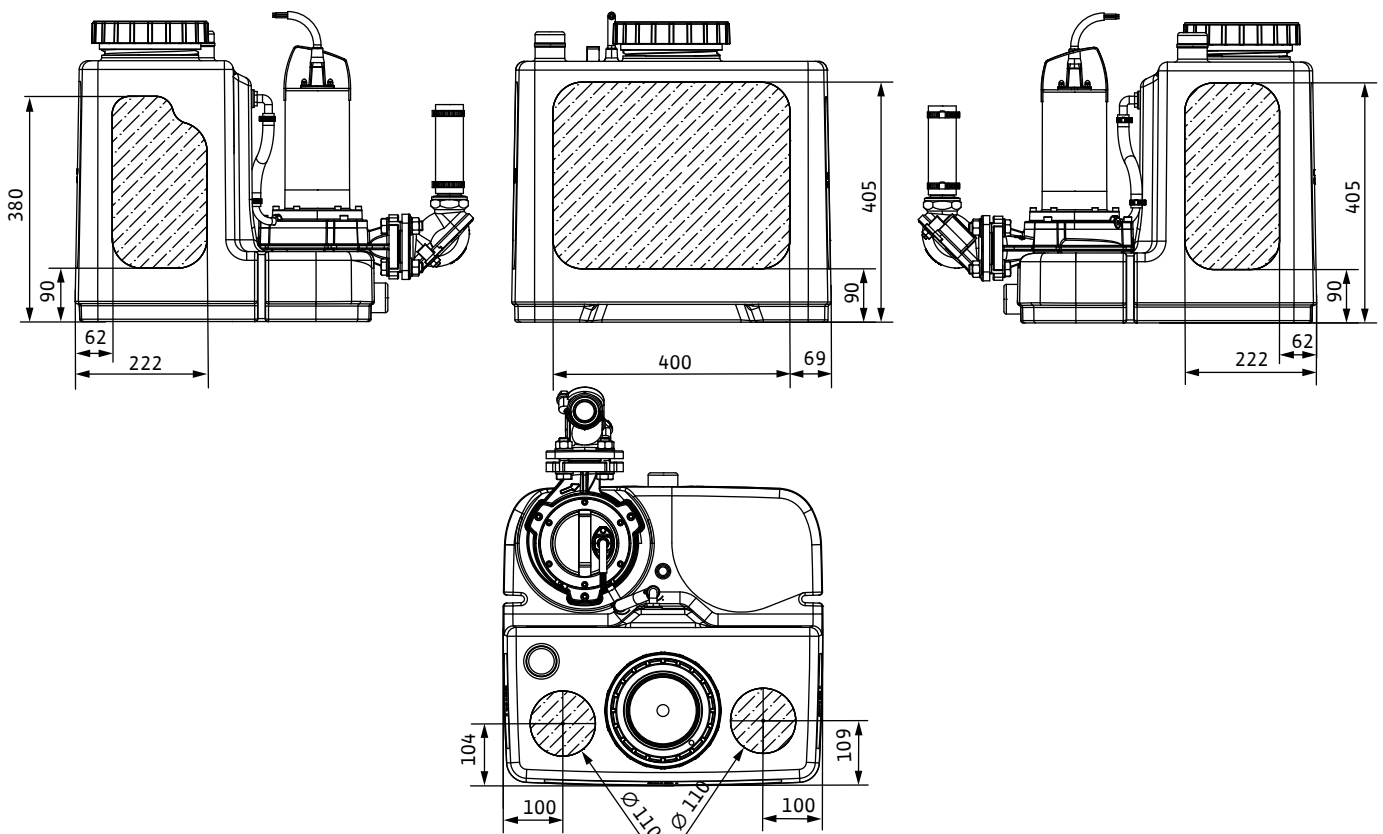



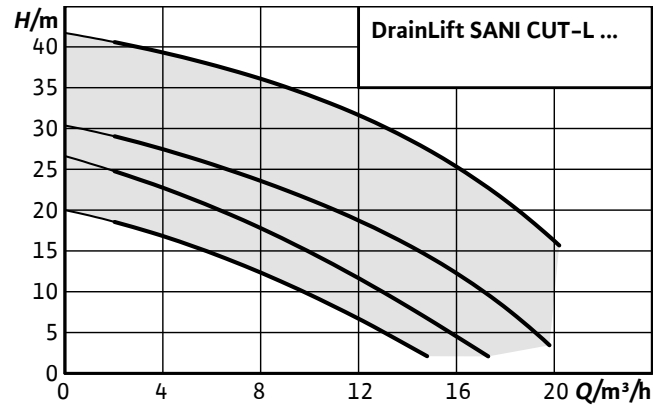

## TECHNICAL DATA

Type Wilo-DrainLift SANI CUT-L	Mains connection	Rated power	Wilo-Control MS-L switchgear	Mains plug	Article number
	V	kW			
20M/1	230	0.75	2x8 A-MDOL-C22-LS	Shockproof plug	6095527
20T/1	400	0.75	2x8 A-T4-DOL-LS	CEE	6095528
27M/1	230	1.1	2x8 A-MDOL-C35-LS	Shockproof plug	6095529
27T/1	400	1.1	2x8 A-T4-DOL-LS	CEE	6095530
30M/1	230	1.5	2x12 A-MDOL-C35-LS	CEE	6095531
30T/1	400	1.5	2x8 A-T4-DOL-LS	CEE	6095532
42T/1	400	2.5	2x8 A-T4-DOL-LS	CEE	6095533

CEE 16 A, 3P + N + PE, 6 h

## DIMENSION DRAWING

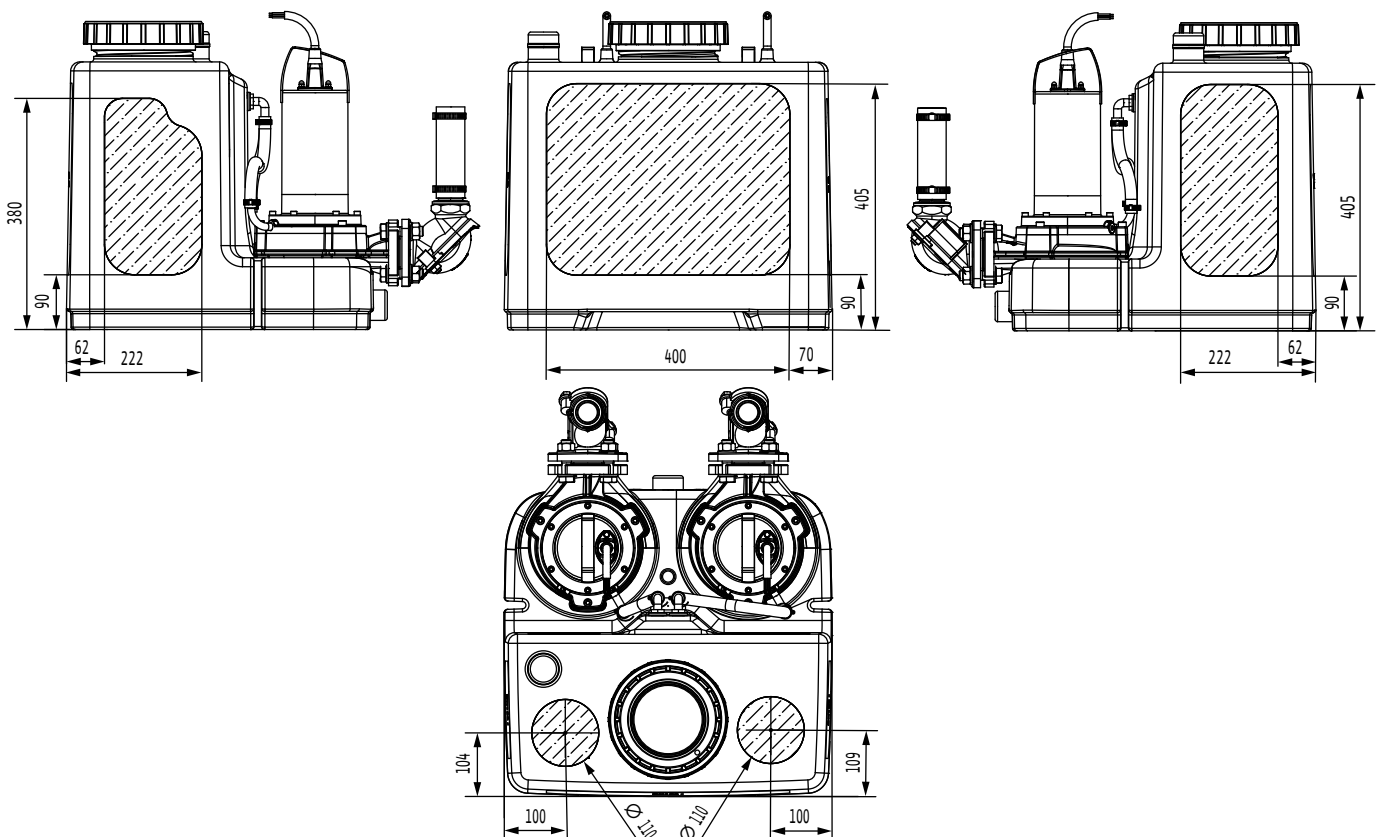

# Wilo-DrainLift SANI CUT

## Accessories

### ELECTRONIC ACCESSORIES

Designation	Article number
Flash light 1~230 VAC	2551613
DrainAlarm	2545133
DrainAlarm FIRST	2550526
Small alarm switchgear KAS	501534094
Signal horn 1~230 V	501459398

### MECHANICAL ACCESSORIES

Designation	Article number
3-way cock Rp 1½	2511607
PVC gate valve DN 100	2529808
PVC gate valve DN 150	2529809
Y-piece DN 32 PVC kit	6096483
Y-piece DN 40 PVC kit	6096484
Diaphragm hand pump	2060166
DN 32 inlet seal kit	6096498
DN 40 inlet seal kit	6096499
DN 100 inlet seal	2522672
DN 150 inlet seal	2552849
DN 200 inlet seal	2552850
Connection kit for inlet DN 32	6096492
Connection kit for inlet DN 40	6096493
Connection kit for inlet DN 100	2521841
Connection kit for inlet DN 150	2515145
Connection kit for inlet DN 200	2552851
Gate valve 1¼" kit	2528652
Gate valve 1½" kit	6096494

# Better together

Wilo has a long tradition of working in partnership with installers and plant engineers. A key element of our partnership philosophy is the Wilo factory customer service. We work with you to develop a service concept tailored to your individual needs. With our expertise and personal consultation we ensure that the operation of your systems is as energy-efficient, reliable and economical as possible. Our professional Wilo Service technicians are ready to assist you with fast, reliable and on-time support. We call it: **Better together.**



## OUR SERVICES AT A GLANCE:

- Commissioning
- System Optimisation
- Follow-up guarantee
- Supervision
- Maintenance and repair
- Spare parts
- WiloCare
- Wilo-ThermoDes mobile
- Repair
- Wilo-Live Assistant
- Energy Solutions



**Wilo maintenance and repair**  
**Operational reliability for your pumps**

We offer you a variety of options for regularly checking that our products operate smoothly and for ensuring that they keep working reliably in the long term. In doing so, we adapt our maintenance solutions to your individual requirements and your products on site. To ensure smooth operation of the system, our experts regularly check, monitor and maintain all the necessary system components.



**Wilo follow-up guarantee**  
**For greater planning and cost security**

Following commissioning of your Wilo product, Wilo offers you a follow-up guarantee with the maintenance and repair contract for your product for up to three years after the warranty has lapsed. For you, this means protection against unexpected repair costs, even after the statutory manufacturer's warranty has expired.

Pioneering for You

wilo



## The Wilo-World

What would it be like if you could look at products and examples of how they work from the comfort of your desk? What would be the added value of a central, virtual starting point that offers information and experience in equal measure? How much would the work be made easier if all the technical data needed for design were available at all times and at any place?

Our answer to that is: welcome to the new, digital world of Wilo! Welcome to Wilo-World.



WILO SE  
Wilopark 1  
44263 Dortmund  
[www.wilo.de](http://www.wilo.de)