

Submittal Data Sheet

Wilco-CO MVI - NSF 61/372 Pressure Boosting System

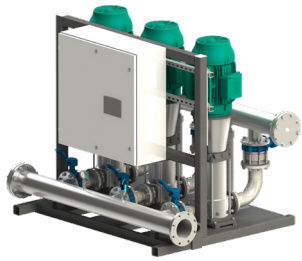

CO3 MVI-450



Project:	
Engineer:	
Contractor:	
Submitted By:	Date:
Approved By:	Date:

Tag #	Model #	Flow	BOOST PSI	Min. Inlet PSI	HP/Pump	Phase	Voltage	RPM
	CO3 MVI-450				1			3600

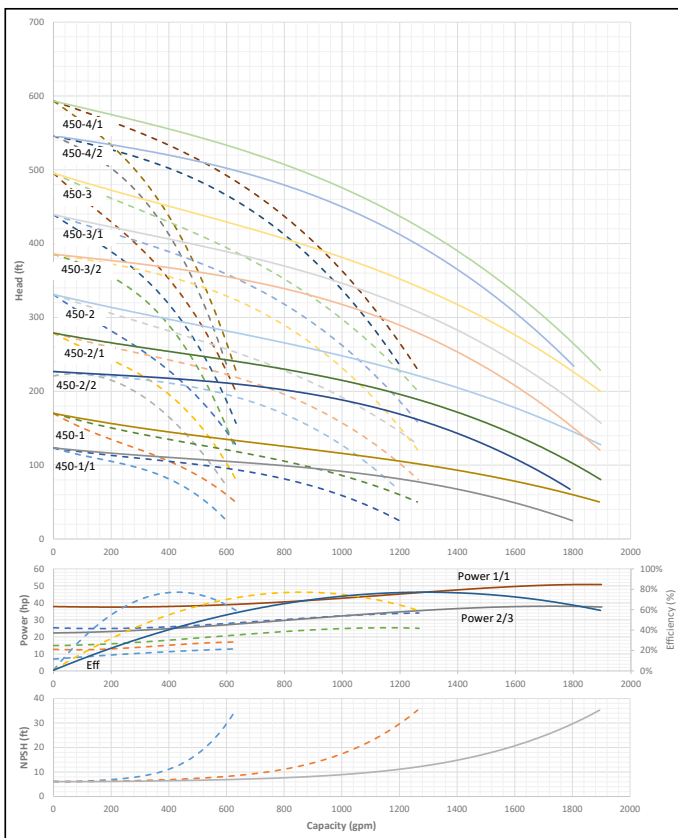

Applications	
• Water Supply	• Pressure Boosting
• Agriculture	• Cooling Circuits
• Washing / Sprinkling Systems	• Condensate Return

Materials of Construction	
Volute	AISI 304 Stainless Steel with Cast Iron ANSI flanges
Impeller	AISI 304 Stainless Steel
Shaft	ANSI 431 Stainless Steel
Elastomers	EPDM
Manifold	AISI 304 Stainless Steel
Suction Isolation Valves	150# Cast Iron Wafer Butterfly, All Stainless Steel Wetted Components
Discharge Isolation Valve	150# Cast Iron Wafer Butterfly, All Stainless Steel Wetted Components or 300# 304SS Ball Valve
Check Valve	Wafer Style, 316 Stainless Steel internals, non-slam, plunger type with EPDM seal/ cast iron body
Mechanical Seal	Frame and Springs 304SS
Pressure Transducers	¼" MNPT, 316 Stainless Steel
Pressure Gauges	¼" MNPT, 304 Stainless Steel Housing with 316 Stainless Steel wetted parts
System Base	Epoxy Coated A-500 Steel Tubing and A36 C-Channel/Plates

Technical Data - Operational Ranges	
Liquid Temp Range	5°F to 248°F (Min. 32 °F for Domestic Water)
Ambient Temp Range	+32°F to +104 °F

Technical Data - Panel	
Liquid Temp Range	208-230/460-3 or 575-3
Enclosure	NEMA 3R up to 20 HP NEMA 12 for 25 HP and above (NEMA 4 and 4X available upon request)
Standard	Meets UL 508A
Variable Frequency Drives	Danfoss FC-101: • 1 HP to 3 HP 208-230V-1 IN / 208-230V-3 OUT • 1 HP to 60 HP 208-230V-3 • 1 HP to 100 HP 460V-3 • 1 HP to 100 HP 575V-3

Technical Data - PLC	
User Interface	7" Diagonal Color LCD Touchscreen
Display Resolution	800 x 480 Pixels
Supply Voltage	24VDC
Max. Current Consumption	320mA@24V
Number of Analog Inputs	4
Number of Analog Outputs	4
Number of Digital Inputs	18
Number of Digital Outputs	17
Onboard Communications	Modbus Protocol (Optional Gateways for BACnet, LonWorks, and CANbus)
Ethernet Port	RJ45 port capable of transmitting data 10/100Mbps
Additional Ports	2.0 USB Port; Micro-SD Port

Motor Data	
Power Supply	208-230, 460, 575-3
Motor Enclosure	Totally Enclosed Fan Cooled (TEFC)
Motor Efficiency	Nema Premium Efficiency - Meets NEMA 12-12 Rule
Enclosure Construction	Rolled Steel / Cast Iron
Motor Protection Index	IP54
Insulation Class	F

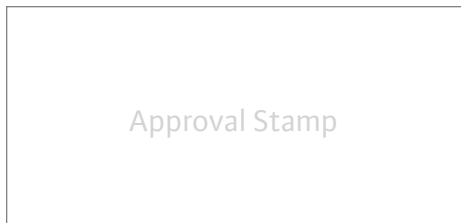

Submittal Data Sheet

Wilo-CO MVI - NSF 61/372 Pressure Boosting System



CO3 MVI-450

150# Discharge

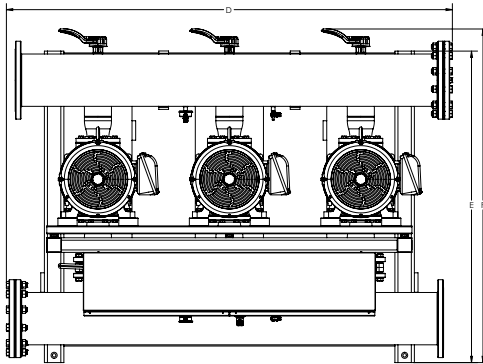
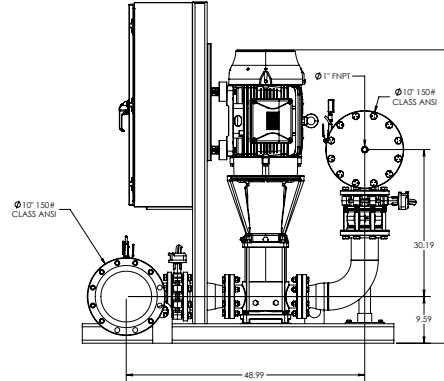
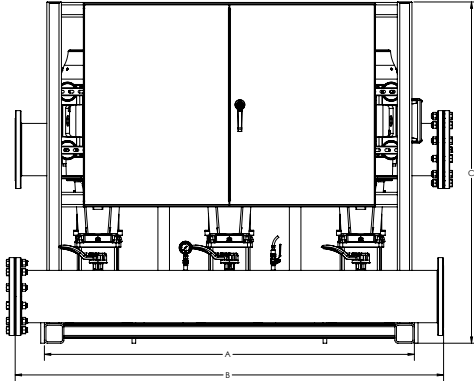

Special Note: All weights and dimensions are approximate and should not be used as exact rough-in dimensions

CO3 MVI-450

TEFC Motor Data (Per Motor)

Dimensions - Inches (in)

Motor FLA (per pump) System FLA

Model	Article	HP	Voltage	Phase	System Header Size (ANSI)	Pmax (PSI)	A (in)	B (in)	C (in)	D (in)	E (in)	F (in)	H (in)	System Weight (Lbs)	(A)	
CO3 MVI-450-1/1	3353453	15	208V-230V	~3	10" 150#	232	70	82	62.1	85.6	64	68.93	51.87	3347.27	38.5-34.8	124-115.6
CO3 MVI-450-1	3353454	15	208V-230V	~3	10" 150#	232	70	82	62.1	85.6	64	68.93	51.87	3347.39	38.5-34.8	124-115.6
CO3 MVI-450-2/2	3353455	25	208V-230V	~3	10" 150#	232	70	82	70.1	85.6	64	68.93	57.72	2878.63	63.0-57.6	196
CO3 MVI-450-2/1	3353456	30	208V-230V	~3	10" 150#	232	70	82	92.1	85.6	64	68.93	57.72	3511.16	76.7-68.4	229
CO3 MVI-450-2	3353457	40	208V-230V	~3	10" 150#	232	76	88	92.1	91.56	64	68.57	60.27	3997.27	101-92.6	312.1
CO3 MVI-450-3/2	3353458	40	208V-230V	~3	10" 150#	232	76	88	92.1	91.56	64	68.57	63.86	4030.27	101-92.6	312.1
CO3 MVI-450-1/1	3353942	15	460V	~3	10" 150#	232	70	82	62.1	85.6	64	68.93	51.87	3076.12	17.4	56.2
CO3 MVI-450-1	3353943	15	460V	~3	10" 150#	232	70	82	62.1	85.6	64	68.93	51.87	3076.24	17.4	56.2
CO3 MVI-450-2/2	3353944	25	460V	~3	10" 150#	232	70	82	62.1	85.6	64	68.93	57.72	3121.31	28.8	88.9
CO3 MVI-450-2/1	3353945	30	460V	~3	10" 150#	232	70	82	62.1	85.6	64	68.93	57.72	3672.2	34.2	104.8
CO3 MVI-450-2	3353946	40	460V	~3	10" 150#	232	76	88	70.1	91.56	64	68.57	60.27	3915.66	46.3	148.6
CO3 MVI-450-3/2	3353947	40	460V	~3	10" 150#	232	76	88	70.1	91.56	64	68.57	63.86	3948.66	46.3	148.6
CO3 MVI-450-3/1	3353948	50	460V	~3	10" 150#	232	76	88	70.1	91.56	64	68.57	63.86	4105.44	56.1	182.8
CO3 MVI-450-3	3353949	50	460V	~3	10" 150#	232	76	88	70.1	91.56	64	68.57	63.86	4105.59	56.1	182.8
CO3 MVI-450-1/1	3354431	15	575V	~3	10" 150#	232	70	82	62.1	85.6	64	68.93	51.87	3240.27	13.8	48.1
CO3 MVI-450-1	3354432	15	575V	~3	10" 150#	232	70	82	62.1	85.6	64	68.93	51.87	3240.39	13.8	48.1
CO3 MVI-450-2/2	3354433	25	575V	~3	10" 150#	232	70	82	70.1	85.6	64	68.93	57.72	2857.63	23	78.1
CO3 MVI-450-2/1	3354434	30	575V	~3	10" 150#	232	70	82	70.1	85.6	64	68.93	57.72	3432.52	27.4	95.5
CO3 MVI-450-2	3354435	40	575V	~3	10" 150#	232	76	88	70.1	91.56	64	68.57	60.27	3927.66	37	129.7
CO3 MVI-450-3/2	3354436	40	575V	~3	10" 150#	232	76	88	70.1	91.56	64	68.57	63.86	3960.66	37	129.7
CO3 MVI-450-3/1	3354437	50	575V	~3	10" 150#	232	76	88	104.1	91.56	64	68.57	63.86	4150.56	44.9	157
CO3 MVI-450-3	3354438	50	575V	~3	10" 150#	232	76	88	104.1	91.56	64	68.57	63.86	4150.71	44.9	157

Submittal Data Sheet

Wilo-CO MVI - NSF 61/372 Pressure Boosting System



CO3 MVI-450

300# Discharge

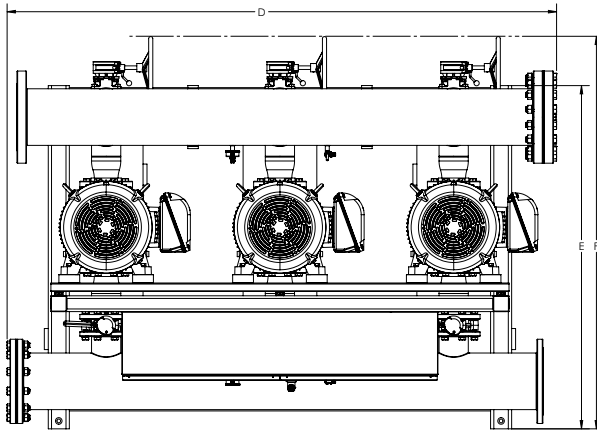
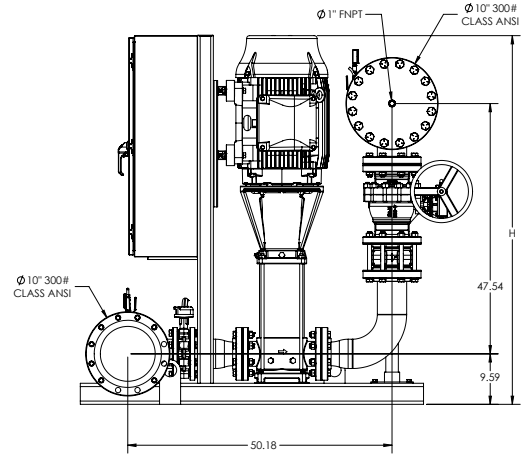
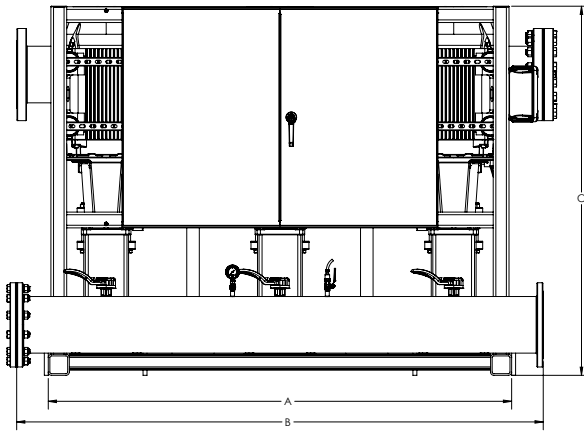

Special Note: All weights and dimensions are approximate and should not be used as exact rough-in dimensions

CO3 MVI-450

CO3 MVI-450															TEFC Motor Data (Per Motor)	
Dimensions - Inches (in)															Motor FLA (per pump)	System FLA
Model	Article	HP	Voltage	Phase	System Header Size (ANSI)	Pmax (PSI)	A (in)	B (in)	C (in)	D (in)	E (in)	F (in)	H (in)	System Weight (Lbs)	(A)	
CO3 MVI-450-4/2	3353950	60	460V	~3	10" 300#	435	88	100	70.1	104.24	65.18	74.5	70.02	5535.25	67	218.5
CO3 MVI-450-4/1	3353951	60	460V	~3	10" 300#	435	88	100	70.1	104.24	65.18	74.5	70.02	5536.39	67	218.5
CO3 MVI-450-4/2	3354439	60	575V	~3	10" 300#	435	88	100	104.1	104.24	65.18	74.5	70.02	5625.37	53.6	190.9
CO3 MVI-450-4/1	3354440	60	575V	~3	10" 300#	435	88	100	104.1	104.24	65.18	74.5	70.02	5626.51	53.6	190.9