

# Submittal Data Sheet

## Wilo SCP – Horizontal Split Case Pumps

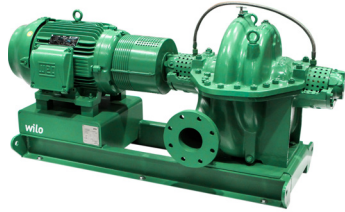

### SCP 20 x 16 x 18½ HA



Project:	
Engineer:	
Contractor:	
Submitted By:	Date:
Approved By:	Date:

Tag #	Model #	Flow (USGPM)	Head (Feet)	HP	Enclosure TEFC/ODP	Frame	Cycle	Phase	Voltage	RPM
	SCP 20 x 16 x 18½ HA						60 Hz	3		

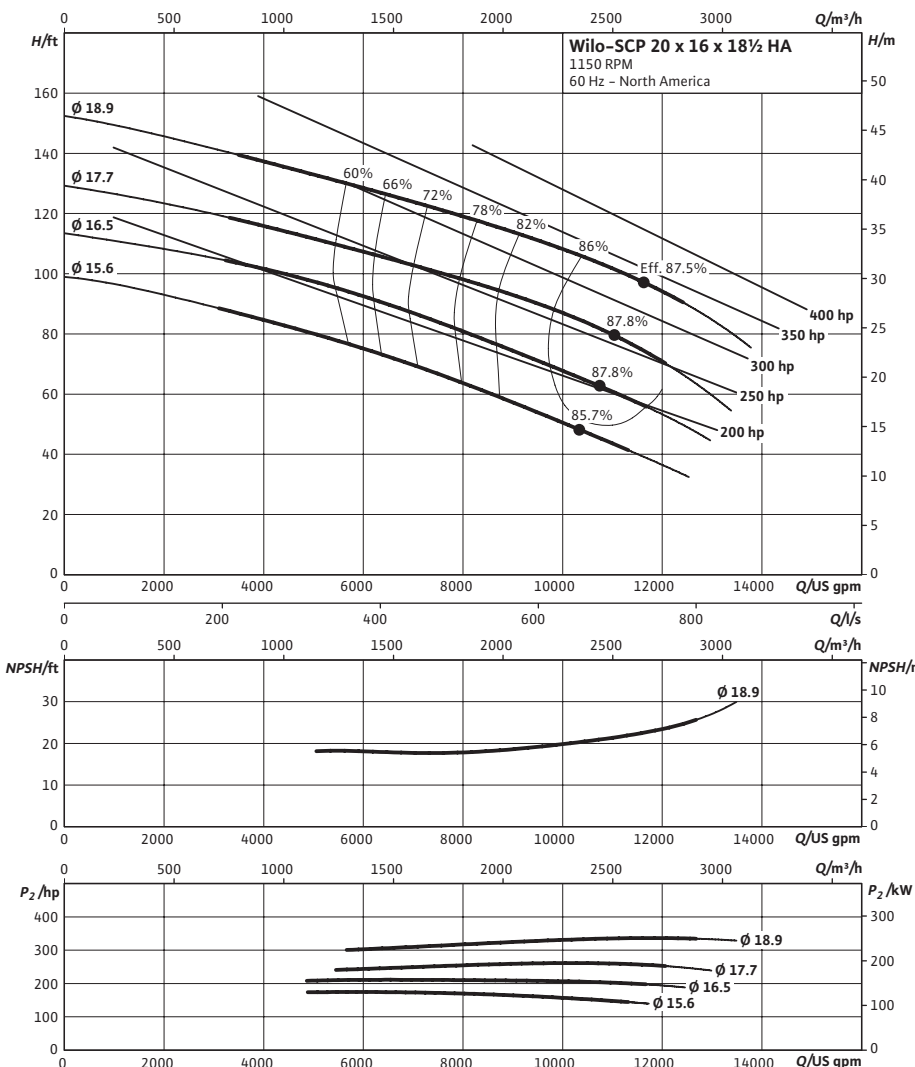

#### Technical Data

<b>Approved Fluids</b>	
Heating Water	
Cooling and cold water	
Water-Glycol mixtures (for 20–40% glycol and fluid temp ≤ 104°F [40°C])	
<b>Fluid Temperature</b>	
Mechanical Seal	18°F to 250°F (–8°C to 120°C)
Stuffing Box Packing	18°F to 220°F (–8°C to 105°C)

#### Materials of Construction

<input type="checkbox"/>	Pump Housing	A48 Class 35
<input type="checkbox"/>	Pump Housing (Optional)	Ni-resist BS 3468 Gr 2 / BS 2789 500.1
<input type="checkbox"/>	Impeller	BS 84 C83 600
<input type="checkbox"/>	Impeller (optional)	A48 Class 35 / BS 84 C83 600
<input type="checkbox"/>	Stationary Wear Rings	BS 84 C93 700
<input type="checkbox"/>	Pump Shaft	A276 type 410
<input type="checkbox"/>	Pump Shaft (optional)	BS 970 316 S16
<input type="checkbox"/>	Mechanical Seal	Carbon/silicon carbide/EPDM (E1)
<input type="checkbox"/>	Other Mechanical Seals	Avail. on request
<input type="checkbox"/>	Additional Spacer Coupling	Avail. on request
<input type="checkbox"/>	Other:	

Approval Stamp

### Dimensional Drawing

### Single Stage Pump

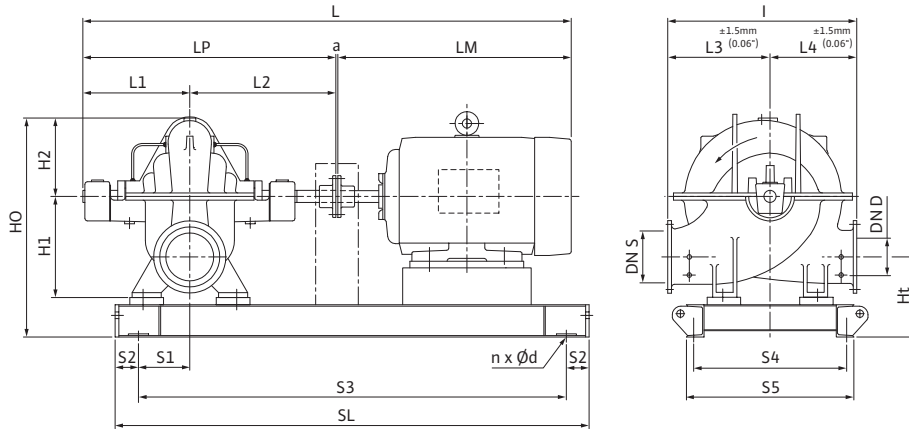

### SCP 20 x 16 x 18½ HA

Dimensions – Inches (mm)

Frame	a	L	I	L1	L2	L3	L4	LM	LP	H1	H2	HO	Ht	n	Ød	S1	S2	S3	S4	S5	SL	P5	P6
445T	.50 (13)	108.00 (2743)	52.56 (1335)	24.81 (630)	29.25 (743)	31.13 (791)	21.44 (545)	53.38 (1356)	54.06 (1373)	30.69 (780)	20.50 (521)	58.13 (1477)	20.19 (513)	4	.91 (23)	16.69 (424)	4.00 (102)	78.44 (1992)	31.13 (842)	33.88 (861)	56.44 (2196)	-	-

Additional Motors Available – CONSULT FACTORY

### Flange Dimensions – Suction Side

Dimensions – Inches (mm)

DN S #125	ØD	Ød	Øk	b	n	D2
20	27.50 (699)	23.00 (584)	25.00 (635)	1.69 (43)	20	1.25 (32)

### Flange Dimensions – Discharge Side

Dimensions – Inches (mm)

DND 125#	ØD	Ød	Øk	b	n	D2
16	23.50 (597)	18.50 (470)	21.25 (540)	1.44 (37)	16	1.13 (29)

