

# Submittal Data Sheet

## Wilo SCP – Horizontal Split Case Pumps

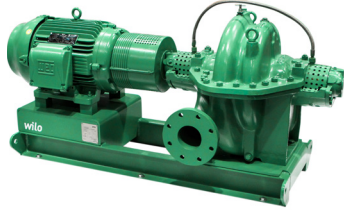

### SCP 16 x 12 x 15½ HA



Project:	
Engineer:	
Contractor:	
Submitted By:	Date:
Approved By:	Date:

Tag #	Model #	Flow (USGPM)	Head (Feet)	HP	Enclosure TEFC/ODP	Frame	Cycle	Phase	Voltage	RPM
	SCP 16 x 12 x 15½ HA						60 Hz	3		

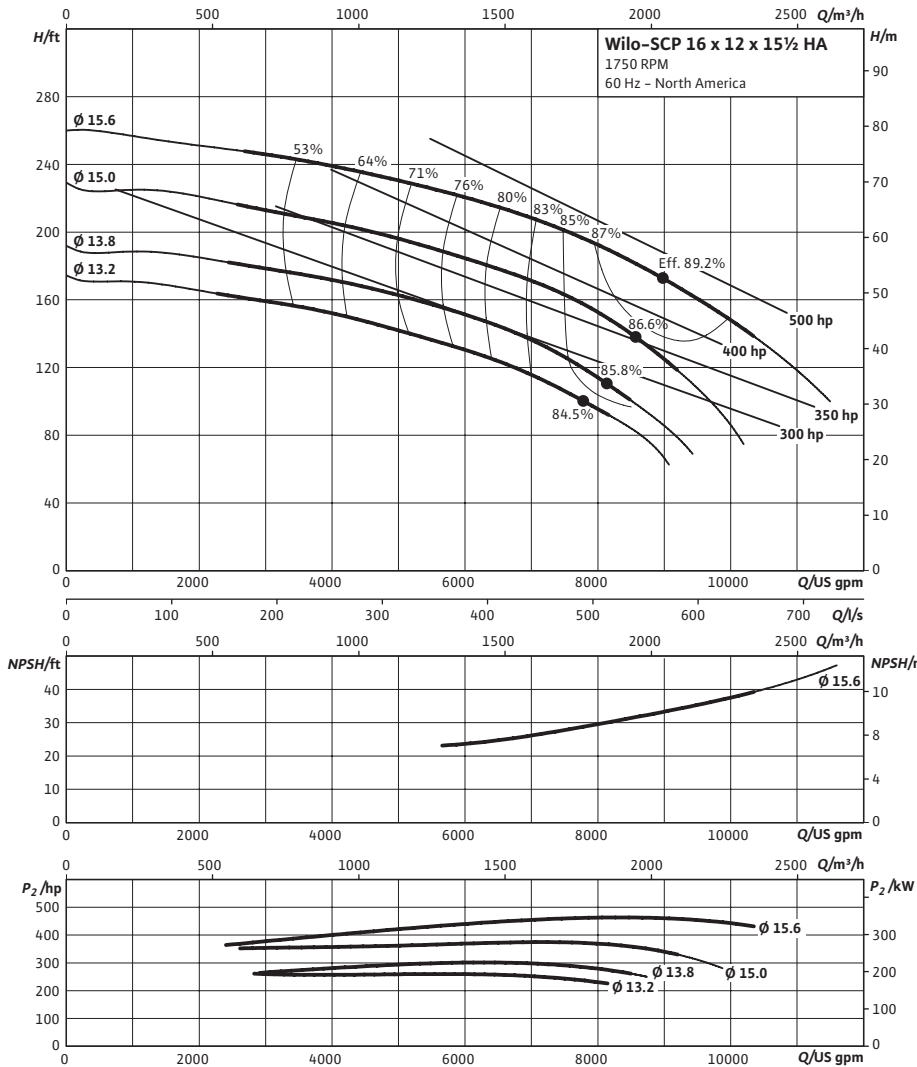

#### Technical Data

##### Approved Fluids

Heating Water  
Cooling and cold water

Water-Glycol mixtures (for 20-40% glycol and fluid temp ≤ 104°F [40°C])

##### Fluid Temperature

Mechanical Seal 18°F to 250°F (-8°C to 120°C)  
Stuffing Box Packing 18°F to 220°F (-8°C to 105°C)

#### Materials of Construction

<input type="checkbox"/>	Pump Housing	A48 Class 35
<input type="checkbox"/>	Pump Housing (Optional)	Ni-resist BS 3468 Gr 2 / BS 2789 500.1
<input type="checkbox"/>	Impeller	BS 84 C83 600
<input type="checkbox"/>	Impeller (optional)	A48 Class 35 / BS 84 C83 600
<input type="checkbox"/>	Stationary Wear Rings	BS 84 C93 700
<input type="checkbox"/>	Pump Shaft	A276 type 410
<input type="checkbox"/>	Pump Shaft (optional)	BS 970 316 S16
<input type="checkbox"/>	Mechanical Seal	Carbon/silicon carbide/EPDM (E1)
<input type="checkbox"/>	Other Mechanical Seals	Avail. on request
<input type="checkbox"/>	Additional Spacer Coupling	Avail. on request
<input type="checkbox"/>	Other:	

Approval Stamp

### Dimensional Drawing

### Single Stage Pump

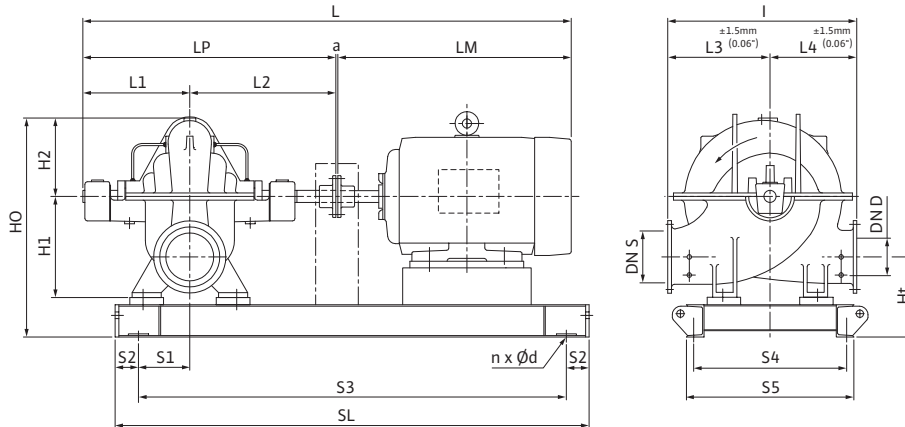

### SCP 16 x 12 x 15½ HA

Dimensions - Inches (mm)

Frame	a	L	I	L1	L2	L3	L4	LM	LP	H1	H2	HO	Ht	n	Ød	S1	S2	S3	S4	S5	SL	P5	P6
449T / 300 hp	.19 (5)	101.75 (2584)	35.44 (900)	21.88 (556)	26.25 (667)	21.63 (549)	13.75 (349)	53.38 (1356)	48.19 (1224)	24.00 (610)	15.38 (391)	45.31 (1151)	16.19 (411)	4	.91 (23)	9.19 (233)	4.00 (102)	68.69 (1745)	21.56 (548)	23.88 (607)	76.69 (1948)	-	-
449T / 350 hp	.19 (5)	101.75 (2584)	35.44 (900)	21.88 (556)	26.25 (667)	21.63 (549)	13.75 (349)	53.38 (1356)	48.19 (1224)	24.00 (610)	15.38 (391)	45.31 (1151)	16.19 (411)	4	.91 (23)	10.75 (273)	4.00 (102)	76.94 (1954)	21.56 (548)	23.88 (607)	84.94 (2157)	-	-
449T / 400 hp	.19 (5)	101.75 (2584)	35.44 (900)	21.88 (556)	26.25 (667)	21.63 (549)	13.75 (349)	53.38 (1356)	48.19 (1224)	24.00 (610)	15.38 (391)	45.31 (1151)	16.19 (411)	4	.91 (23)	10.75 (273)	4.00 (102)	76.94 (1954)	21.56 (548)	23.88 (607)	84.94 (2157)	-	-

### Flange Dimensions - Suction Side

Dimensions - Inches (mm)

DN S #125	ØD	Ød	Øk	b	n	D2
16	23.50 (597)	18.50 (570)	21.25 (540)	1.38 (37)	16	1.13 (29)

### Flange Dimensions - Discharge Side

Dimensions - Inches (mm)

DN D 125#	ØD	Ød	Øk	b	n	D2
12	19 (483)	15.00 (381)	17.00 (432)	1.25 (32)	12	1.00 (25)

