

Submittal Data Sheet

Wilco SCP - Horizontal Split Case Pumps

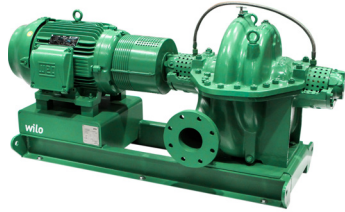

SCP 8 x 8 x 21½ HA



Project:	
Engineer:	
Contractor:	
Submitted By:	Date:
Approved By:	Date:

Tag #	Model #	Flow (USGPM)	Head (Feet)	HP	Enclosure TEFC/ODP	Frame	Cycle	Phase	Voltage	RPM
	SCP 8 x 8 x 21½ HA						60 Hz	3		

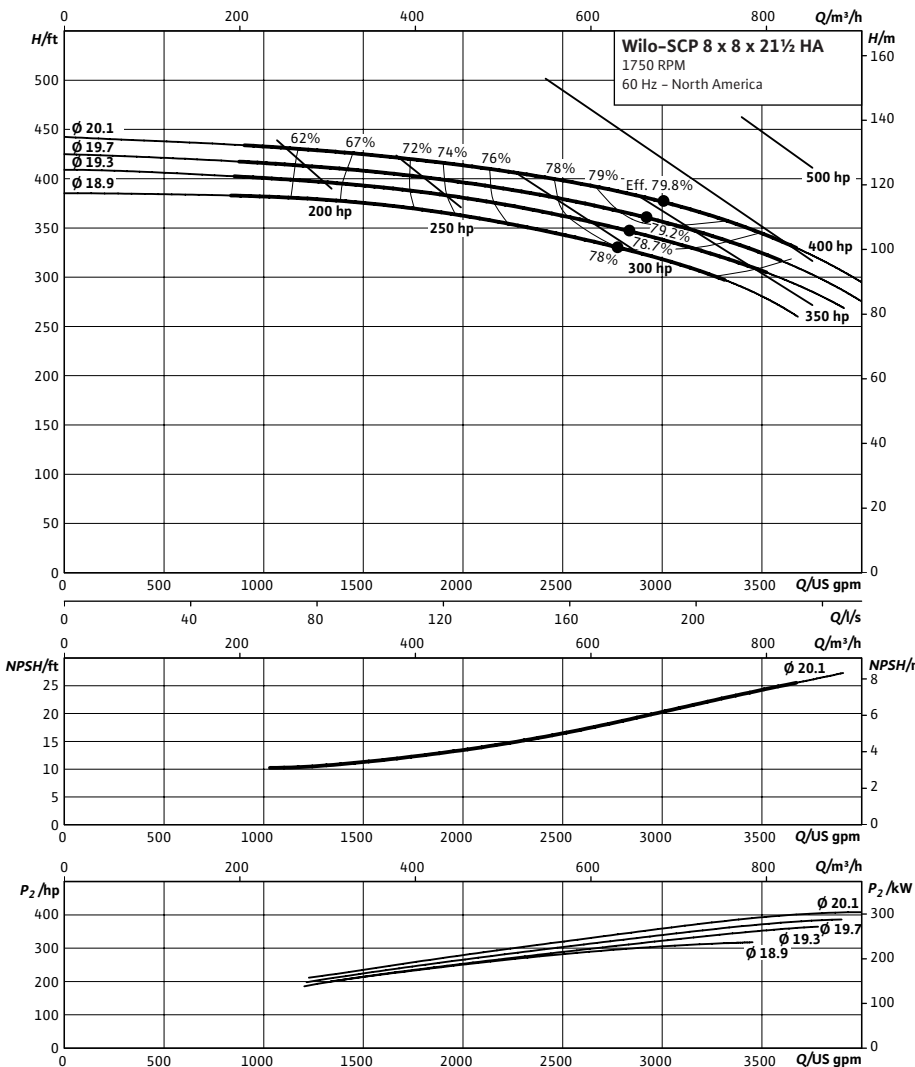

Technical Data

Approved Fluids	
Heating Water	
Cooling and cold water	
Water-Glycol mixtures (for 20-40% glycol and fluid temp ≤ 104°F [40°C])	
Fluid Temperature	
Mechanical Seal	18°F to 250°F (-8°C to 120°C)
Stuffing Box Packing	18°F to 220°F (-8°C to 105°C)

Materials of Construction

<input type="checkbox"/> Pump Housing	A48 Class 35
<input type="checkbox"/> Pump Housing (Optional)	Ni-resist BS 3468 Gr 2 / BS 2789 500.1
<input type="checkbox"/> Impeller	BS 84 C83 600
<input type="checkbox"/> Impeller (optional)	A48 Class 35 / BS 84 C83 600
<input type="checkbox"/> Stationary Wear Rings	BS 84 C93 700
<input type="checkbox"/> Pump Shaft	A276 type 410
<input type="checkbox"/> Pump Shaft (optional)	BS 970 316 S16
<input type="checkbox"/> Mechanical Seal	Carbon/silicon carbide/EPDM (E1)
<input type="checkbox"/> Other Mechanical Seals	Avail. on request
<input type="checkbox"/> Additional Spacer Coupling	Avail. on request
<input type="checkbox"/> Other:	

Approval Stamp

Dimensional Drawing

Single Stage Pump

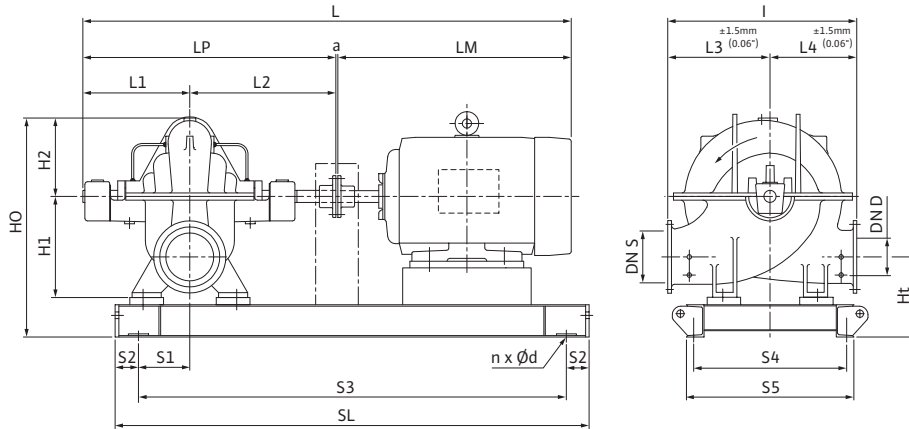

SCP 8 x 8 x 21½ HA

Dimensions - Inches (mm)

Frame	a	L	I	L1	L2	L3	L4	LM	LP	H1	H2	HO	Ht	n	Ød	S1	S2	S3	S4	S5	SL	P5	P6
445T / 200 hp	.50 (13)	89.50 (2273)	36.50 (927)	20.69 (526)	24.13 (613)	18.50 (470)	18.00 (457)	44.25 (1124)	44.75 (1137)	18.25 (464)	14.56 (370)	38.63 (981)	10.56 (268)	4	.91 (23)	6.25 (159)	4.00 (102)	62.81 (1595)	21.56 (548)	23.88 (607)	70.81 (1799)	-	-
445T / 250 hp	.19 (5)	92.69 (2354)	36.50 (927)	20.69 (526)	24.13 (613)	18.50 (470)	18.00 (457)	47.75 (1213)	44.75 (1137)	18.25 (464)	14.56 (370)	38.63 (981)	10.56 (268)	4	.91 (23)	6.25 (159)	4.00 (102)	63.56 (1614)	21.56 (548)	23.88 (607)	71.56 (1818)	-	-
445T / 300 hp	.19 (5)	98.38 (2499)	36.50 (927)	20.69 (526)	24.13 (613)	18.50 (470)	18.00 (457)	53.38 (1356)	44.75 (1137)	18.25 (464)	14.56 (370)	38.63 (981)	10.56 (268)	4	.91 (23)	6.25 (159)	4.00 (102)	63.56 (1614)	21.56 (548)	23.88 (607)	71.56 (1818)	-	-
449T / 350 hp	.19 (5)	98.38 (2499)	36.50 (927)	20.69 (526)	24.13 (613)	18.50 (470)	18.00 (457)	53.38 (1356)	44.75 (1137)	18.25 (464)	14.56 (370)	38.63 (981)	10.56 (268)	4	.91 (23)	6.25 (159)	4.00 (102)	71.81 (1824)	21.06 (535)	23.88 (607)	79.81 (2027)	-	-
449T / 400 hp	.19 (5)	98.38 (2499)	36.50 (927)	20.69 (526)	24.13 (613)	18.50 (470)	18.00 (457)	53.38 (1356)	44.75 (1137)	18.25 (464)	14.56 (370)	38.63 (981)	10.56 (268)	4	.91 (23)	6.25 (159)	4.00 (102)	71.81 (1824)	21.06 (535)	23.88 (607)	79.81 (2027)	-	-

Flange Dimensions – Suction Side

Dimensions - Inches (mm)

DN S #125	ØD	Ød	Øk	b	n	D2
8	13.50 (343)	10.63 (270)	11.75 (298)	1.13 (29)	8	.88 (22)

Flange Dimensions – Discharge Side

Dimensions - Inches (mm)

DN D 125#	ØD	Ød	Øk	b	n	D2
8	13.50 (343)	10.63 (270)	11.75 (298)	1.13 (29)	8	.88 (22)

