

Submittal Data Sheet

Wilco SCP - Horizontal Split Case Pumps

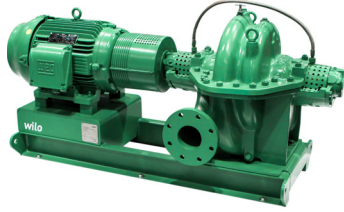

SCP 5 x 4 x 16 DS



Project:	
Engineer:	
Contractor:	
Submitted By:	Date:
Approved By:	Date:

Tag #	Model #	Flow (USGPM)	Head (Feet)	HP	Enclosure TEFC/ODP	Frame	Cycle	Phase	Voltage	RPM
	SCP 5 x 4 x 16 DS						60 Hz	3		

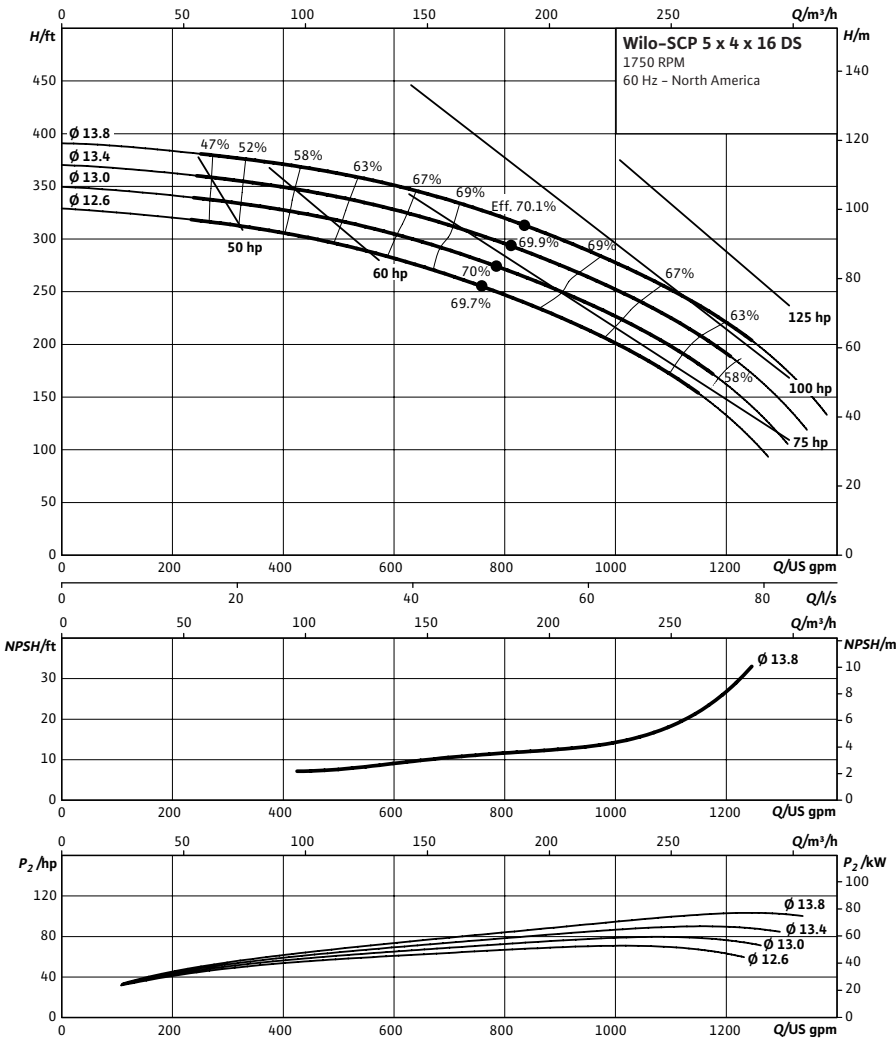

Technical Data

Approved Fluids

Heating Water
Cooling and cold water

Water-Glycol mixtures (for 20-40% glycol and fluid temp ≤ 104°F [40°C])

Fluid Temperature

Mechanical Seal: 18°F to 250°F (-8°C to 120°C)
Stuffing Box Packing: 18°F to 220°F (-8°C to 105°C)

Materials of Construction

<input type="checkbox"/>	Pump Housing	A48 Class 35
<input type="checkbox"/>	Pump Housing (Optional)	Ni-resist BS 3468 Gr 2 / BS 2789 500.1
<input type="checkbox"/>	Impeller	BS 84 C83 600
<input type="checkbox"/>	Impeller (optional)	A48 Class 35 / BS 84 C83 600
<input type="checkbox"/>	Stationary Wear Rings	BS 84 C93 700
<input type="checkbox"/>	Pump Shaft	A276 type 410
<input type="checkbox"/>	Pump Shaft (optional)	BS 970 316 S16
<input type="checkbox"/>	Mechanical Seal	Carbon/silicon carbide/EPDM (E1)
<input type="checkbox"/>	Other Mechanical Seals	Avail. on request
<input type="checkbox"/>	Additional Spacer Coupling	Avail. on request
<input type="checkbox"/>	Other:	

Approval Stamp

Dimensional Drawing

Dual Stage Pump

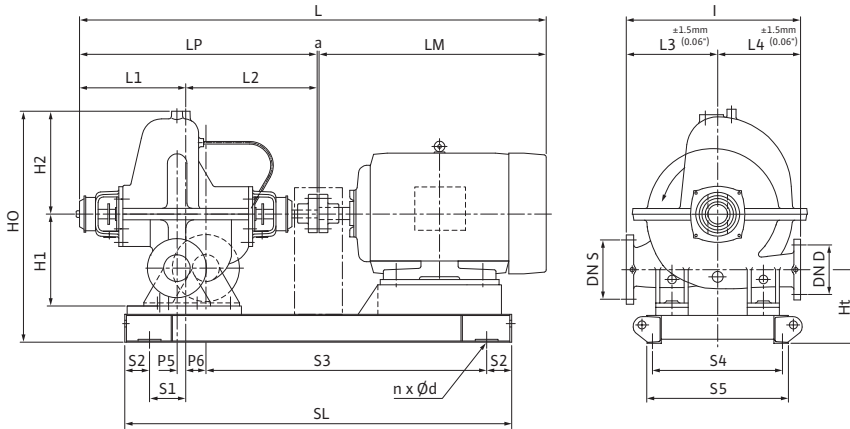

SCP 5 x 4 x 16 DS

Dimensions - Inches (mm)

Frame	a	L	I	L1	L2	L3	L4	LM	LP	H1	H2	HO	Ht	n	Ød	S1	S2	S3	S4	S5	SL	P5	P6
326T	.50 (13)	69.25 (1759)	24.44 (376)	18.31 (465)	20.06 (510)	12.63 (321)	11.81 (300)	30.38 (772)	38.38 (975)	13.75 (349)	14.38 (365)	33.81 (859)	10.75 (273)	4	.91 (23)	3.00 (76)	4.00 (102)	44.94 (1141)	15.81 (402)	18.13 (461)	54.94 (1345)	1.56 (40)	4.00 (102)
364T	.50 (13)	71.88 (1826)	24.44 (376)	18.31 (465)	20.06 (510)	12.63 (321)	11.81 (300)	33.00 (838)	38.38 (975)	13.75 (349)	14.38 (365)	33.81 (859)	10.75 (273)	4	.91 (23)	3.00 (76)	4.00 (102)	46.44 (1180)	15.81 (402)	18.13 (461)	54.44 (1383)	1.56 (40)	4.00 (102)
365T	.50 (13)	71.88 (1826)	24.44 (376)	18.31 (465)	20.06 (510)	12.63 (321)	11.81 (300)	33.00 (838)	38.38 (975)	13.75 (349)	14.38 (365)	33.81 (859)	10.75 (273)	4	.91 (23)	3.00 (76)	4.00 (102)	46.44 (1180)	15.81 (402)	18.13 (461)	54.44 (1383)	1.56 (40)	4.00 (102)
404T	.50 (13)	76.13 (1934)	24.44 (376)	18.31 (465)	20.06 (510)	12.63 (321)	11.81 (300)	37.25 (946)	38.38 (975)	13.75 (349)	14.38 (365)	33.81 (859)	10.75 (273)	4	.91 (23)	3.00 (76)	4.00 (102)	50.44 (1281)	18.50 (470)	20.88 (530)	58.44 (1484)	1.56 (40)	4.00 (102)
405T	.50 (13)	83.13 (2112)	24.44 (376)	18.31 (465)	20.06 (510)	12.63 (321)	11.81 (300)	44.25 (1124)	38.38 (975)	13.75 (349)	14.38 (365)	33.81 (859)	10.75 (273)	4	.91 (23)	3.00 (76)	4.00 (102)	50.44 (1281)	18.50 (470)	20.88 (530)	58.44 (1484)	1.56 (40)	4.00 (102)

Flange Dimensions – Suction Side

Dimensions - Inches (mm)

DN S #125	ØD	Ød	Øk	b	n	D2
5	10.00 (254)	7.31 (186)	8.50 (216)	.94 (24)	8	.88 (22)

Flange Dimensions – Discharge Side

Dimensions - Inches (mm)

DN D 125#	ØD	Ød	Øk	b	n	D2
4	9.00 (229)	6.19 (157)	7.50 (191)	.94 (24)	8	.75 (19)

