

Submittal Data Sheet

Wilo SCP – Horizontal Split Case Pumps

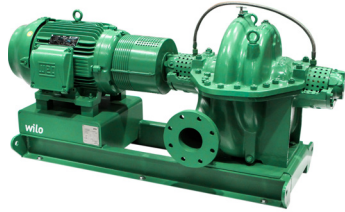

SCP 4 x 3 x 9 HA



Project:	
Engineer:	
Contractor:	
Submitted By:	Date:
Approved By:	Date:

Tag #	Model #	Flow (USGPM)	Head (Feet)	HP	Enclosure TEFC/ODP	Frame	Cycle	Phase	Voltage	RPM
	SCP 4 x 3 x 9 HA						60 Hz	3		

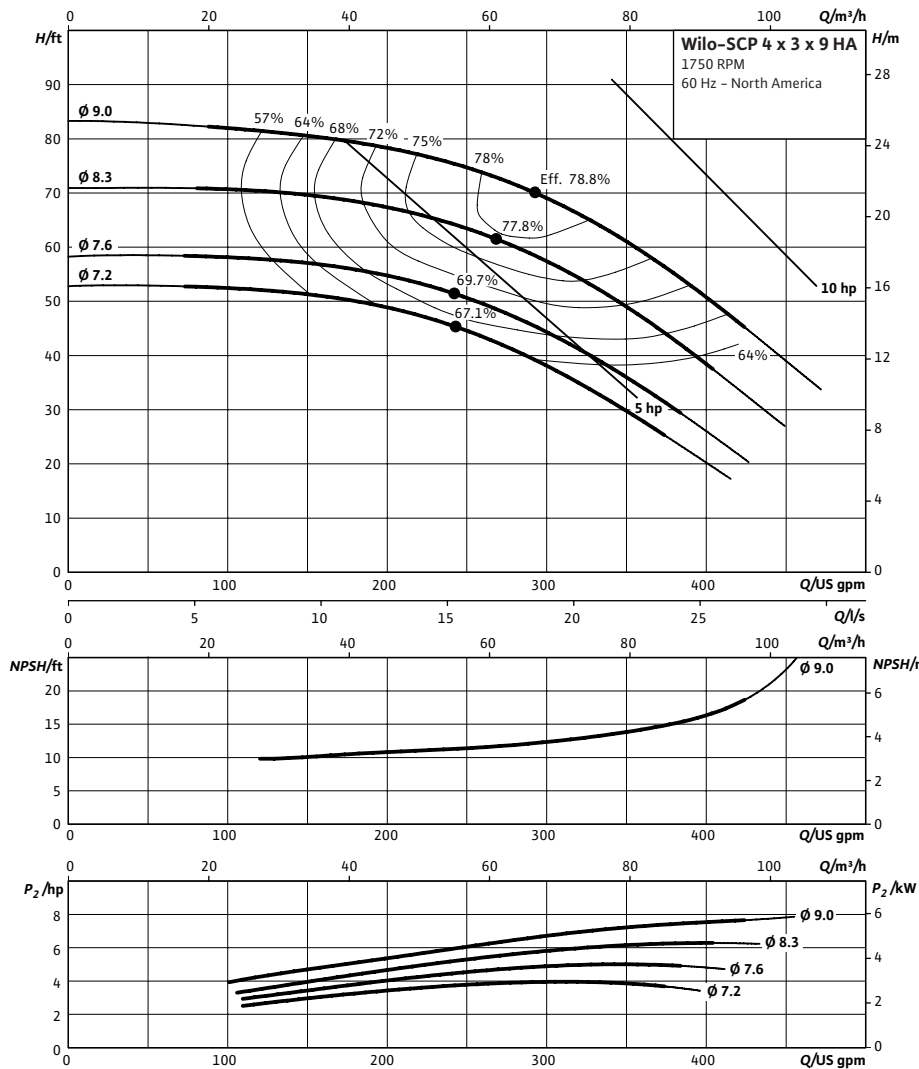

Technical Data

Approved Fluids

Heating Water
Cooling and cold water

Water-Glycol mixtures (for 20-40% glycol and fluid temp ≤ 104°F [40°C])

Fluid Temperature

Mechanical Seal 18°F to 250°F (-8°C to 120°C)
Stuffing Box Packing 18°F to 220°F (-8°C to 105°C)

Materials of Construction

<input type="checkbox"/>	Pump Housing	A48 Class 35
<input type="checkbox"/>	Pump Housing (Optional)	Ni-resist BS 3468 Gr 2 / BS 2789 500.1
<input type="checkbox"/>	Impeller	BS 84 C83 600
<input type="checkbox"/>	Impeller (optional)	A48 Class 35 / BS 84 C83 600
<input type="checkbox"/>	Stationary Wear Rings	BS 84 C93 700
<input type="checkbox"/>	Pump Shaft	A276 type 410
<input type="checkbox"/>	Pump Shaft (optional)	BS 970 316 S16
<input type="checkbox"/>	Mechanical Seal	Carbon/silicon carbide/EPDM (E1)
<input type="checkbox"/>	Other Mechanical Seals	Avail. on request
<input type="checkbox"/>	Additional Spacer Coupling	Avail. on request
<input type="checkbox"/>	Other:	

Approval Stamp

Dimensional Drawing

Single Stage Pump

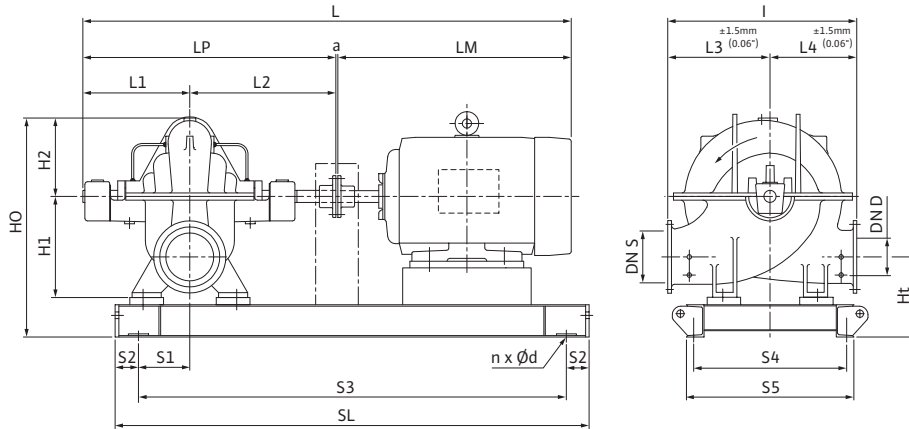

SCP 4 x 3 x 9 HA

Dimensions - Inches (mm)

Frame	a	L	I	L1	L2	L3	L4	LM	LP	H1	H2	HO	Ht	n	Ød	S1	S2	S3	S4	S5	SL	P5	P6
184T	.50 (13)	46.38 (1178)	16.31 (414)	13.63 (346)	15.69 (398)	8.88 (226)	7.50 (191)	16.56 (421)	29.38 (746)	9.81 (249)	6.50 (165)	21.00 (533)	8.75 (222)	4	.91 (23)	1.69 (43)	4.00 (102)	27.00 (686)	10.25 (260)	11.88 (302)	35.0 (889)	-	-
213T	.50 (13)	47.75 (1213)	16.31 (414)	13.63 (346)	15.69 (398)	8.88 (226)	7.50 (191)	17.88 (454)	29.38 (746)	9.81 (249)	6.50 (165)	21.00 (533)	8.75 (222)	4	.91 (23)	1.69 (43)	4.00 (102)	29.88 (759)	10.31 (262)	11.88 (302)	37.88 (962)	-	-
215T	.50 (13)	48.88 (1242)	16.31 (414)	13.63 (346)	15.69 (398)	8.88 (226)	7.50 (191)	19.00 (483)	29.38 (746)	9.81 (249)	6.50 (165)	21.00 (533)	8.75 (222)	4	.91 (23)	1.69 (43)	4.00 (102)	29.88 (759)	10.31 (262)	11.88 (302)	37.88 (962)	-	-

Flange Dimensions – Suction Side

Dimensions - Inches (mm)

DN S #125	ØD	Ød	Øk	b	n	D2
4	9.00 (229)	6.19 (157)	7.50 (191)	.94 (24)	8	.75 (19)

Flange Dimensions – Discharge Side

Dimensions - Inches (mm)

DN D 125#	ØD	Ød	Øk	b	n	D2
3	7.50 (191)	5.50 (140)	6.00 (152)	.94 (24)	4	.75 (19)

