

Wilo-SiBoost Smart... Wilo-SiBoost2.0 Smart...

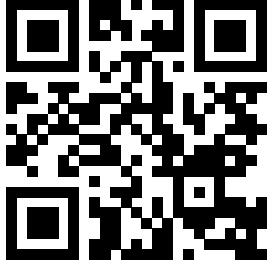

en Installation and operating instructions



SiBoost2.0 Smart Helix VE
<https://qr.wilo.com/495>



SiBoost Smart Helix VE
<https://qr.wilo.com/676>

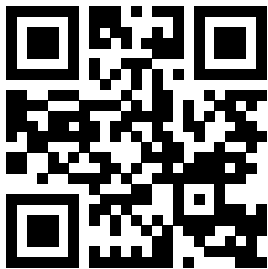

SiBoost Smart MWISE
<https://qr.wilo.com/625>

Fig. 1a

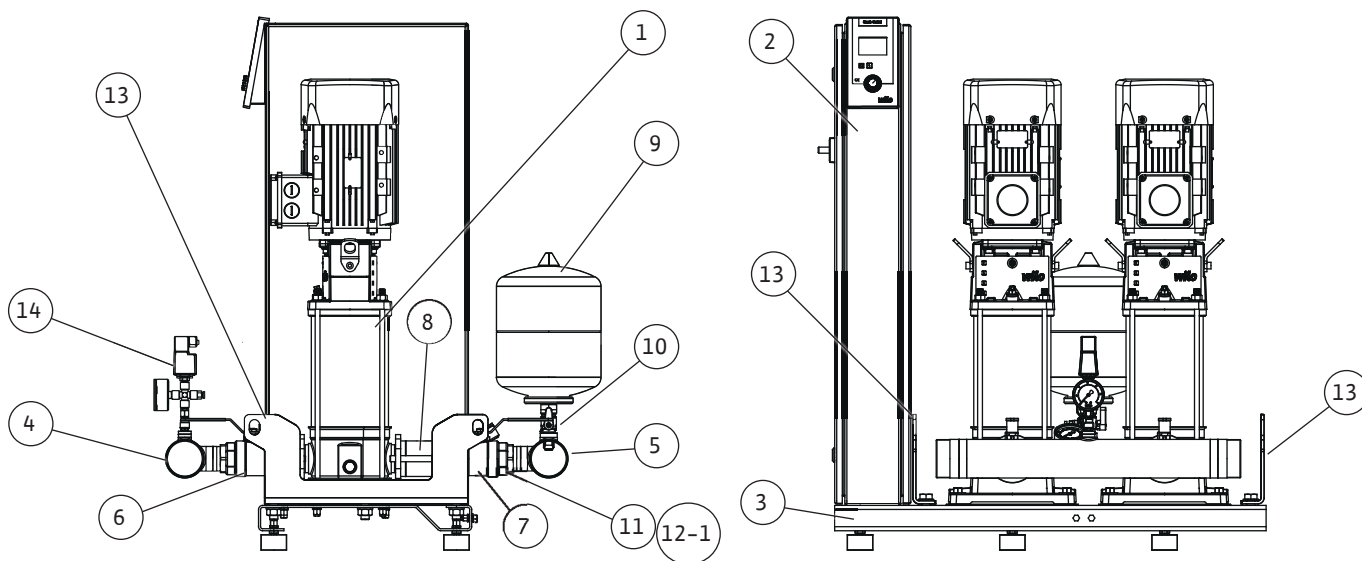

Fig. 1b

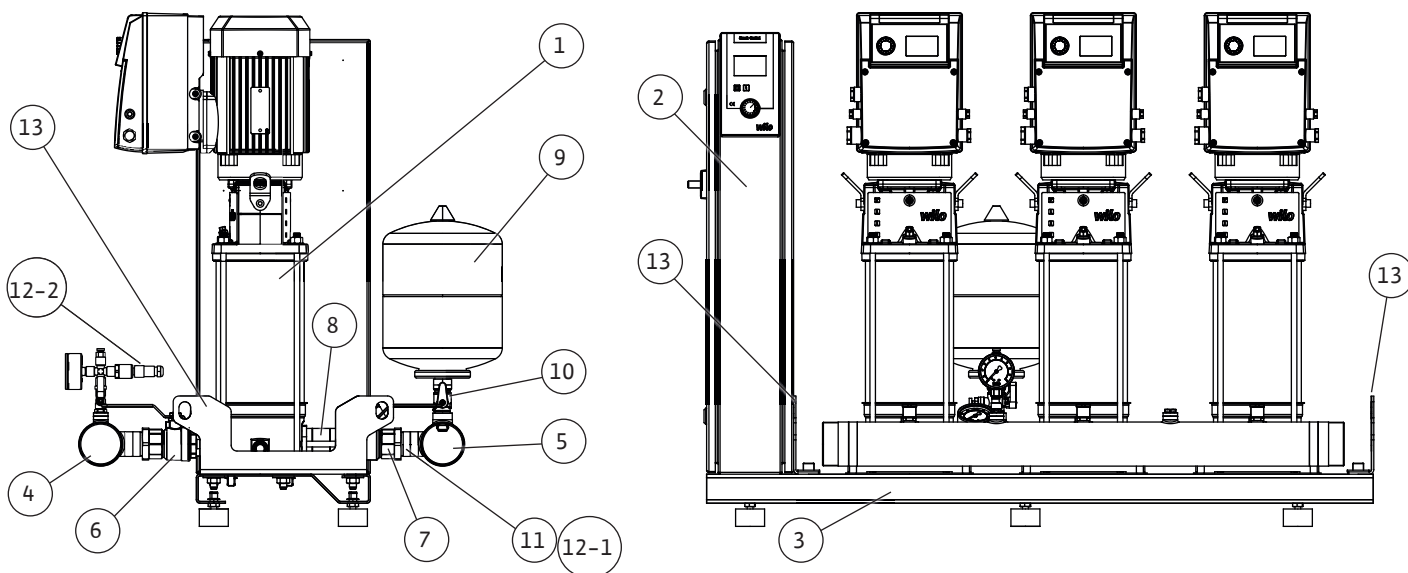

Fig. 1c

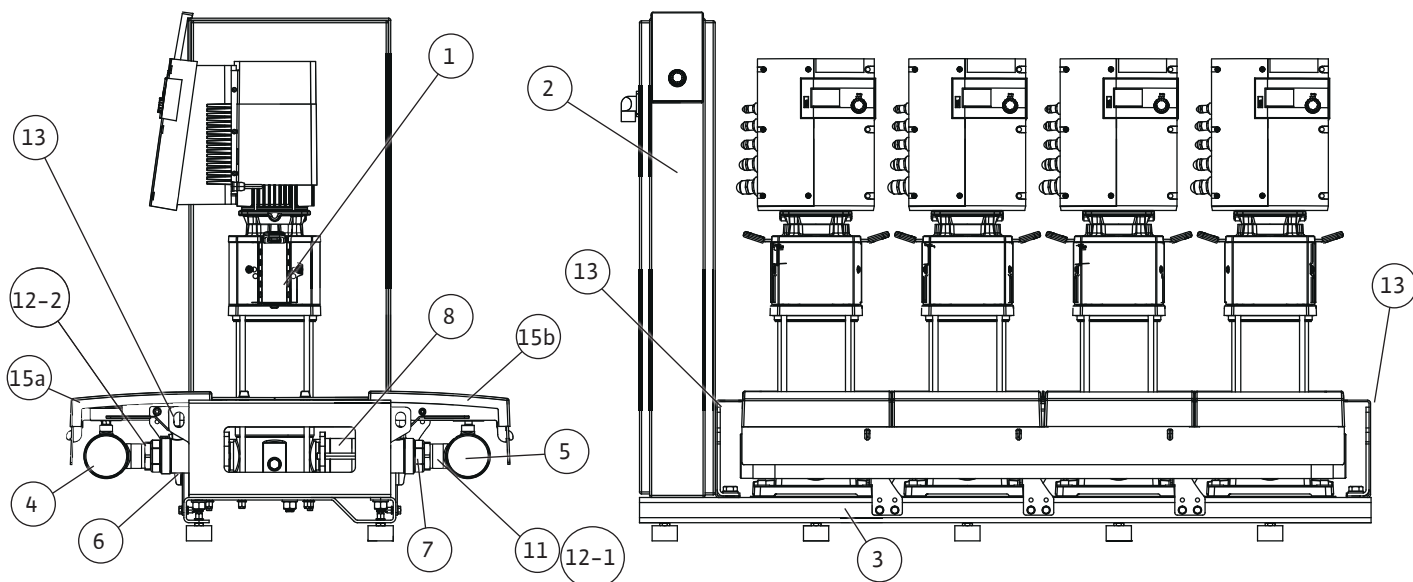

Fig. 1d

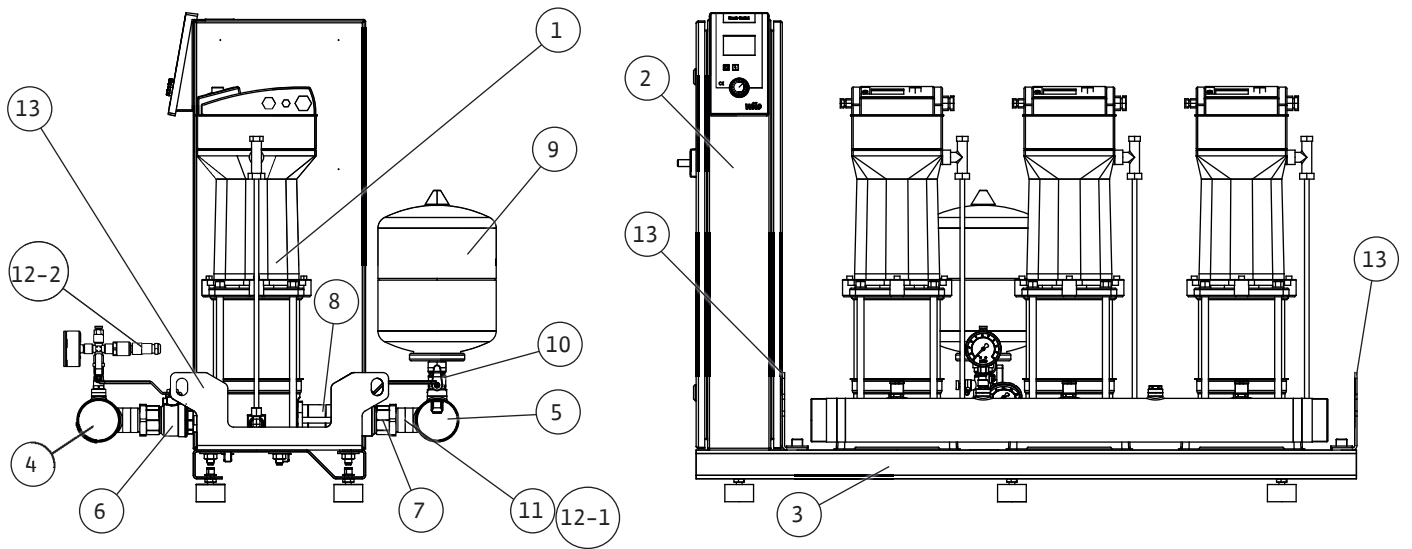

Fig. 1e

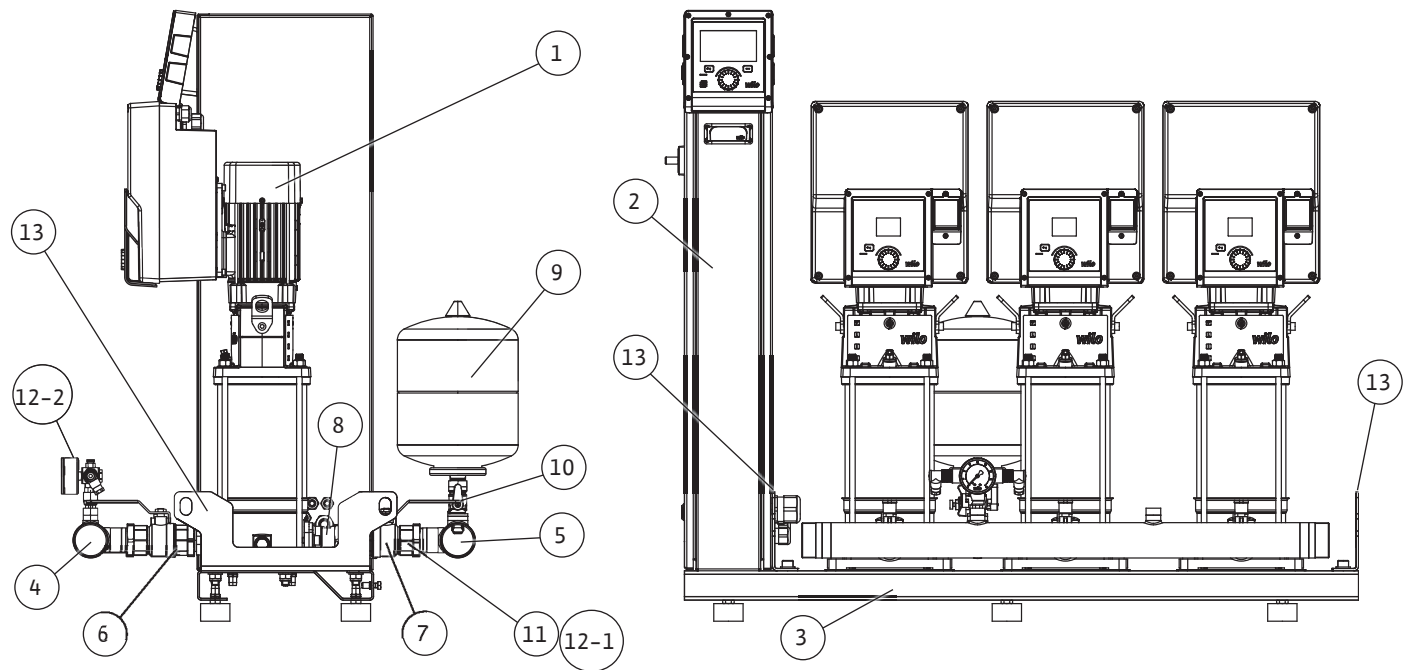

Fig. 2a

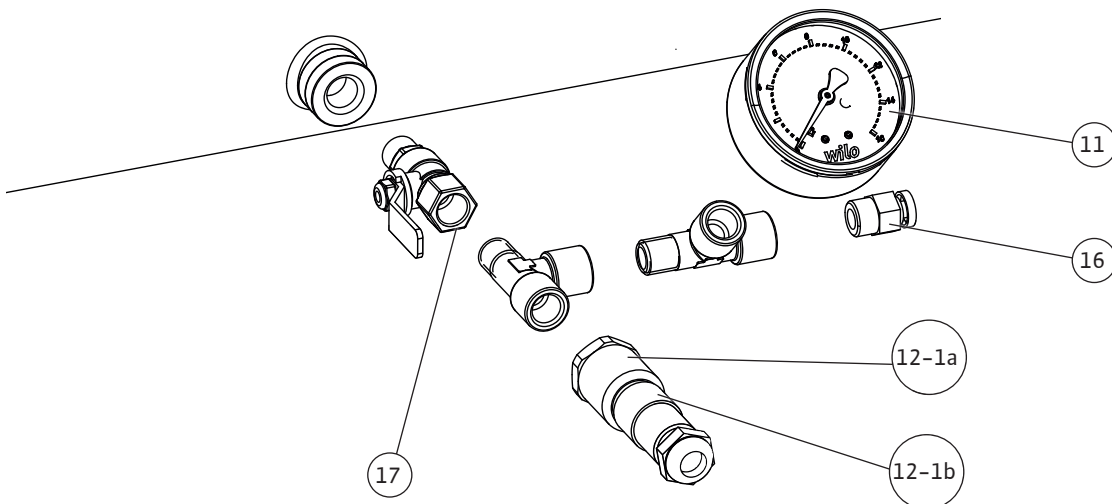
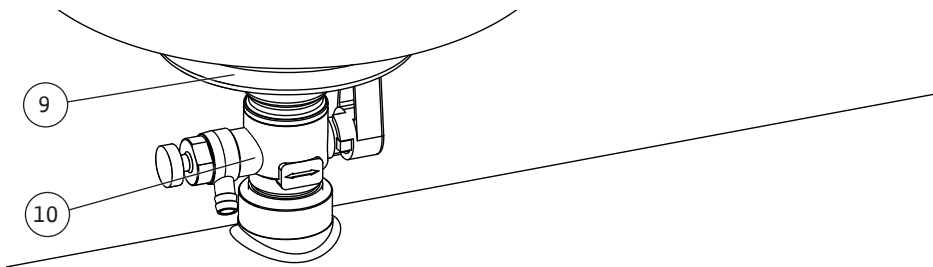
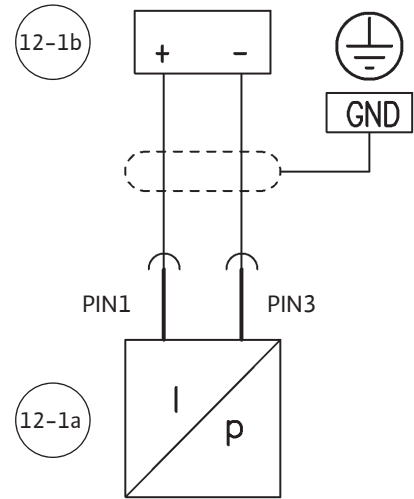
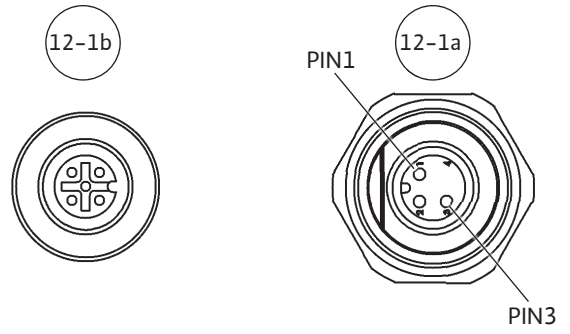
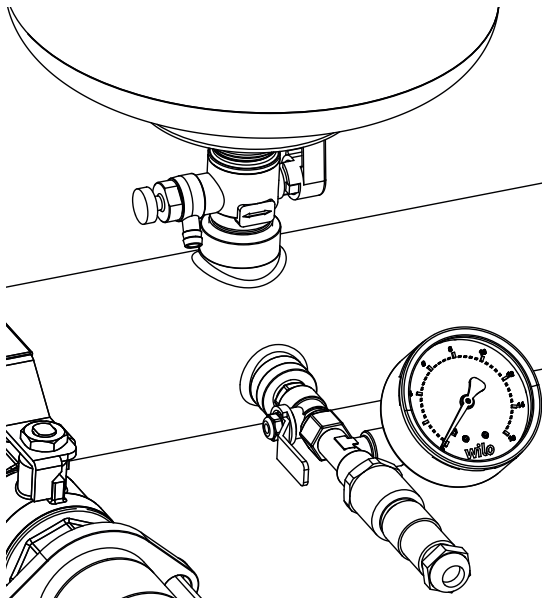

Fig. 2b

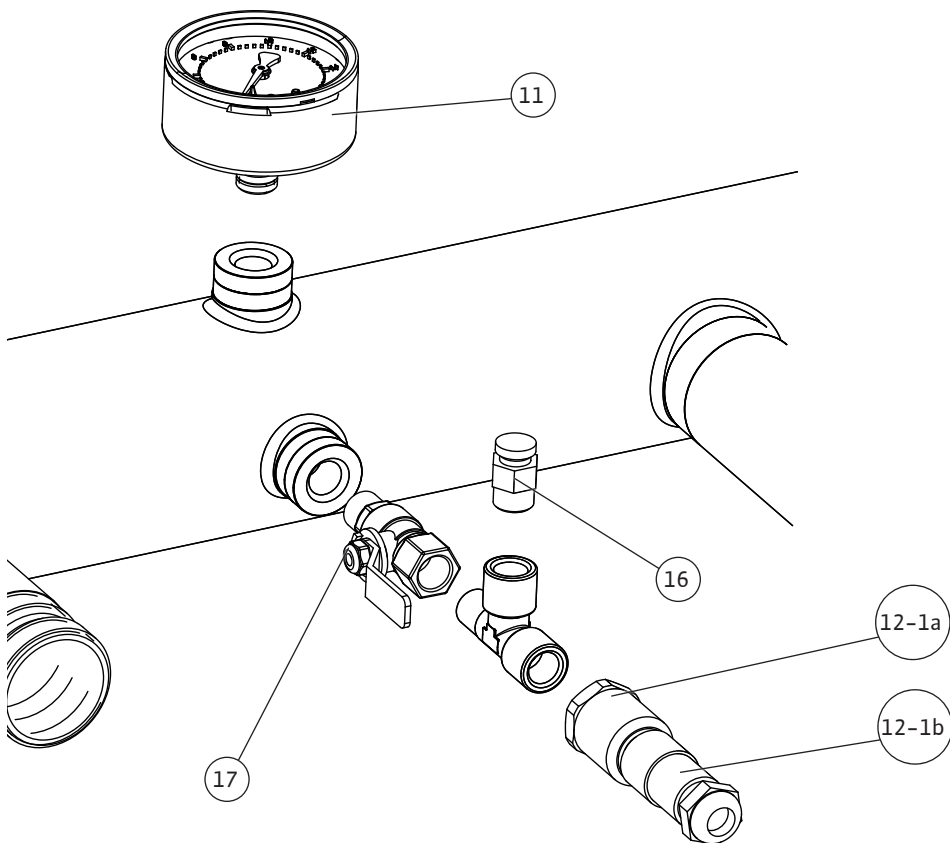
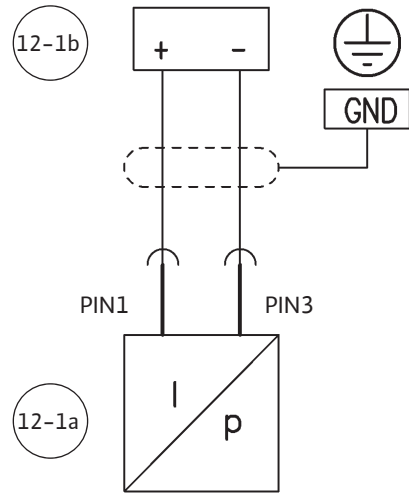
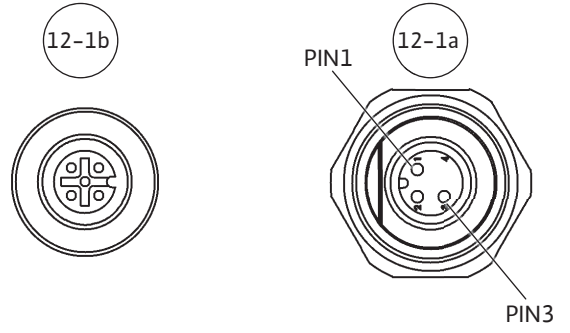
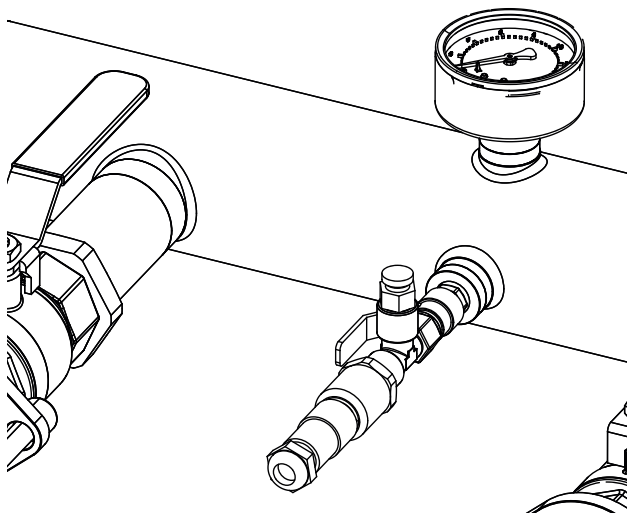

Fig. 2c

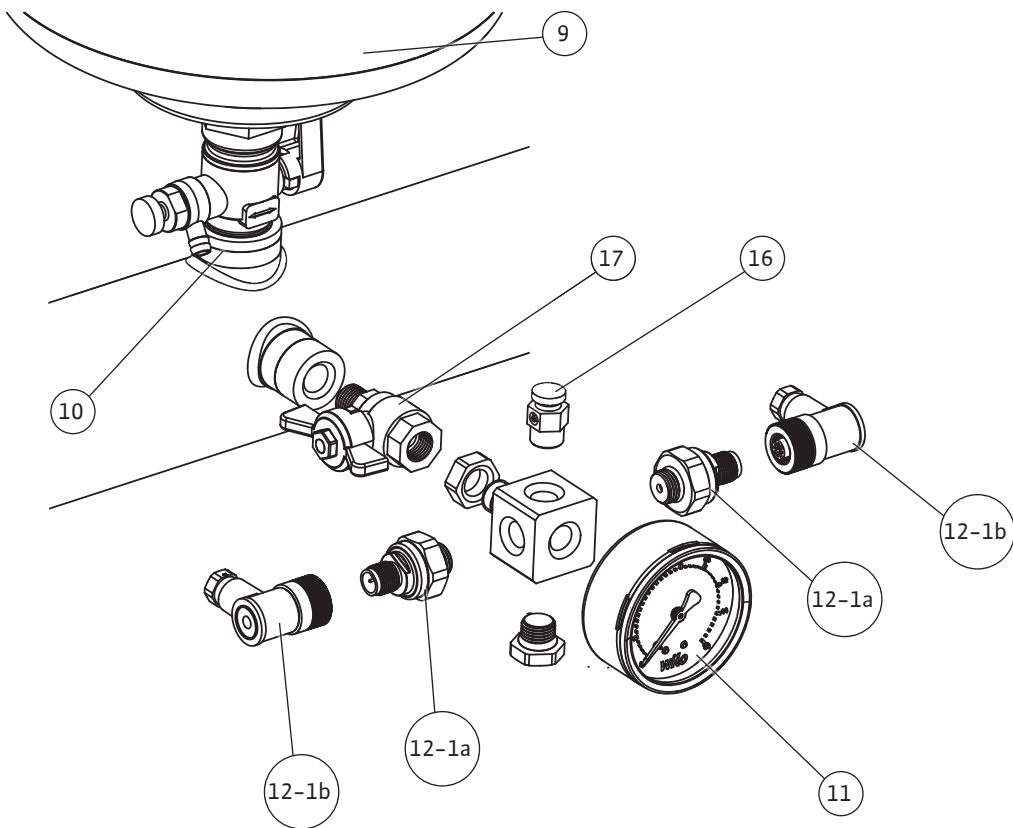
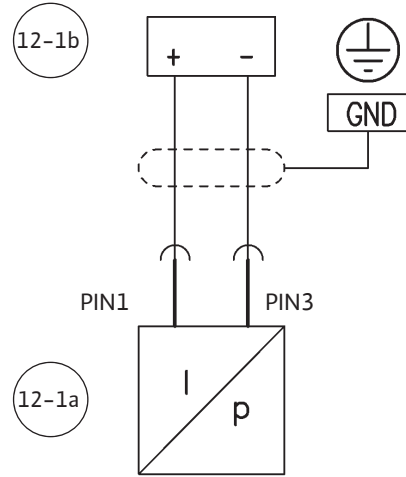
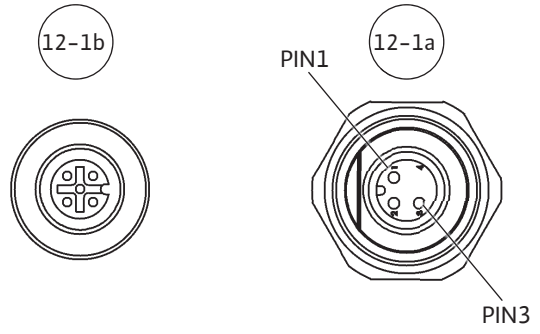
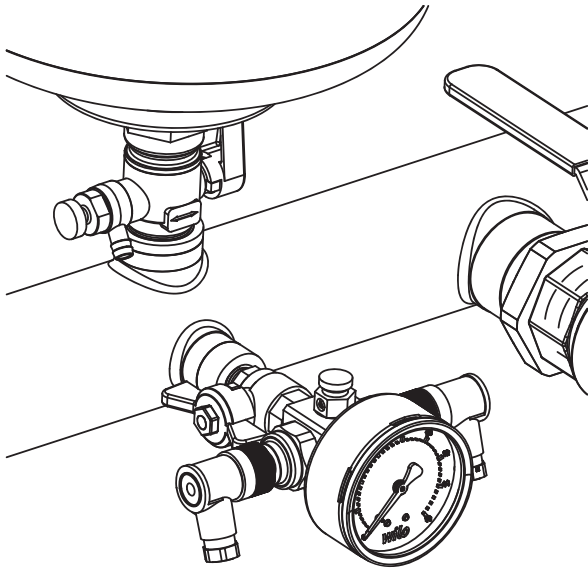

Fig. 3

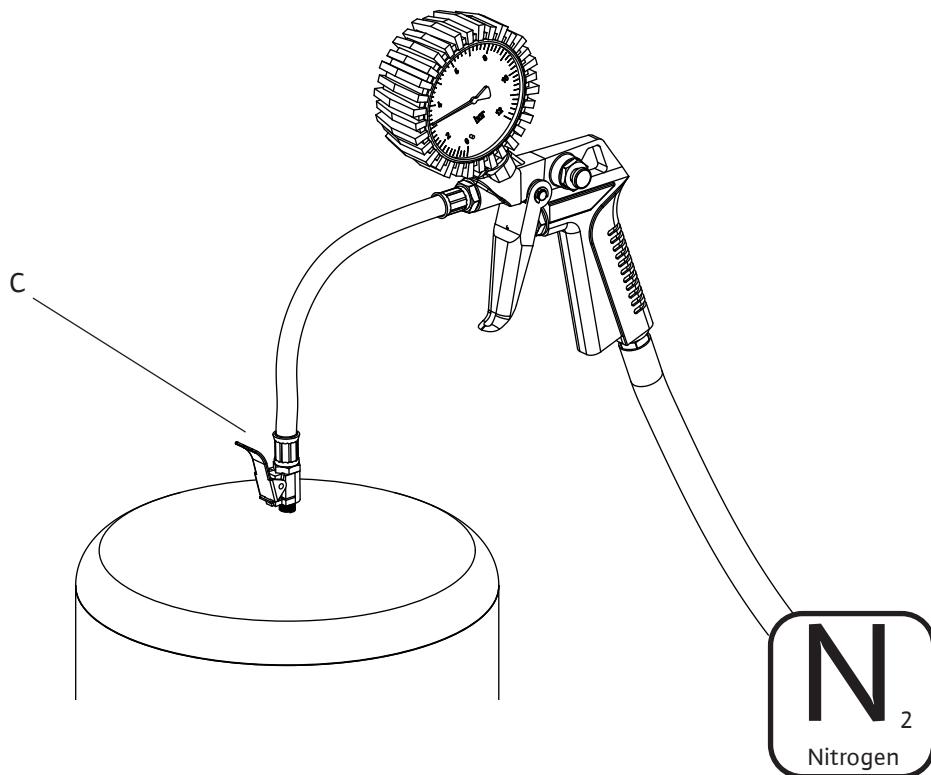
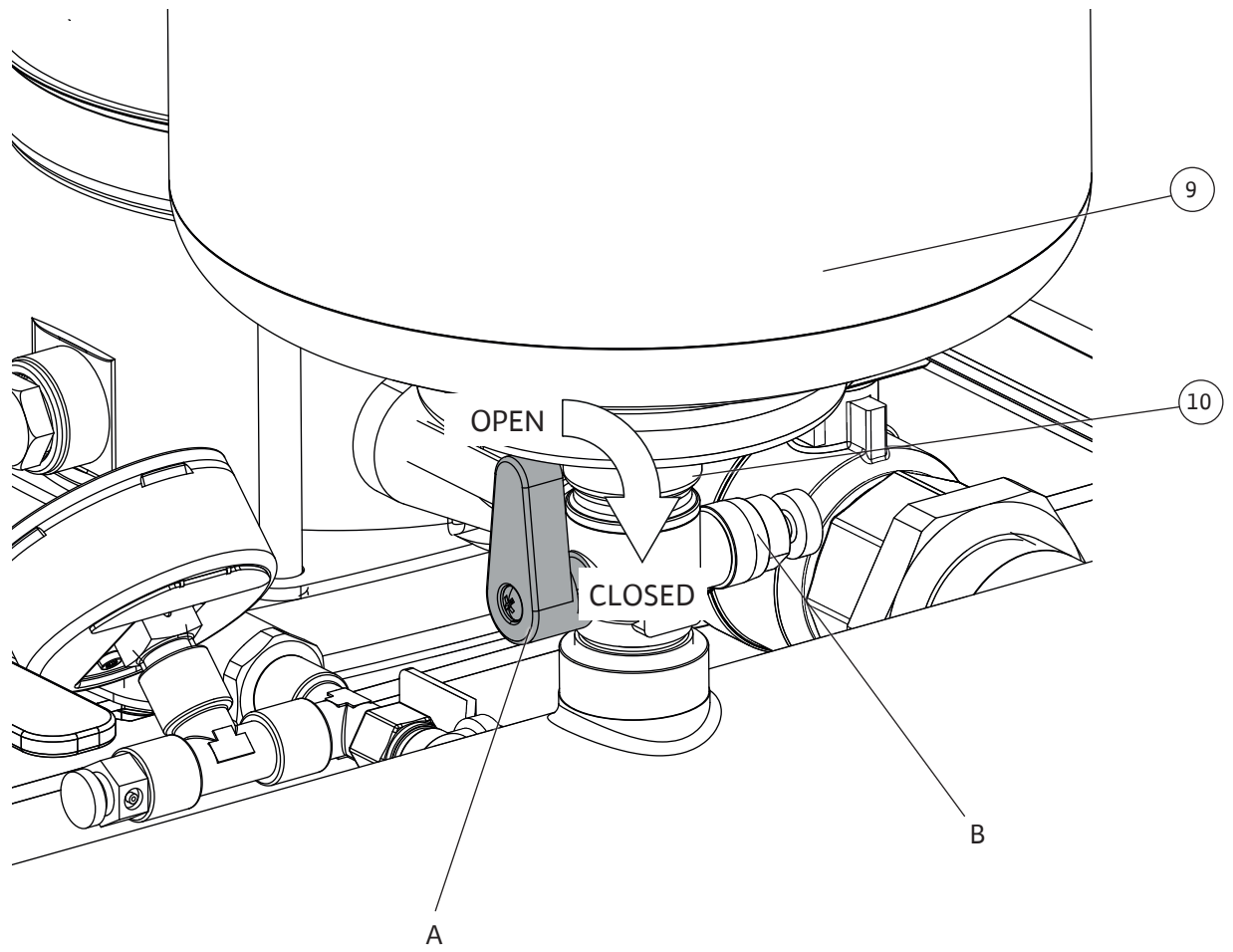

Fig. 4

Hinweis / advice / attention / atención

Stickstoffdruck entsprechend der Tabelle / Nitrogen pressure according to the table
 Pression d'azote conformément au tableau / Presión del nitrógeno según la tabla

PE [bar] Einschaltdruck / starting pressure / Pression de démarrage / Comenzar la presión

PN₂ [bar] Stickstoffdruck / Nitrogen pressure / Pression d'azote / Presión del nitrógeno

PE	2	2,5	3	3,5	4	4,5	5	5,5	6	6,5	7	7,5
PN ₂	1,8	2,3	2,8	3,2	3,7	4,2	4,7	5,2	5,7	6,1	6,6	7,1

PE	8	8,5	9	9,5	10	10,5	11	11,5	12	12,5	13	13,5
PN ₂	7,5	8	8,5	9	9,5	10	10,5	11	11,5	12	12,5	13

1bar = 100000Pa = 0,1MPa = 0,1N/mm² = 10200kp/m² = 1,02kp/cm²(at) = 0,987atm = 750Torr = 10,2mWs

Stickstoffmessung ohne Wasser / Nitrogen measurement without water /

Mesure d'azote sans l'eau / Medida del nitrógeno sin el agua

Achtung: Nur Stickstoff einfüllen / Note: Only fill in nitrogen /

Respect : Seulement l'azote remplir / Nota: Completar solamente el nitrógeno

Fig. 5

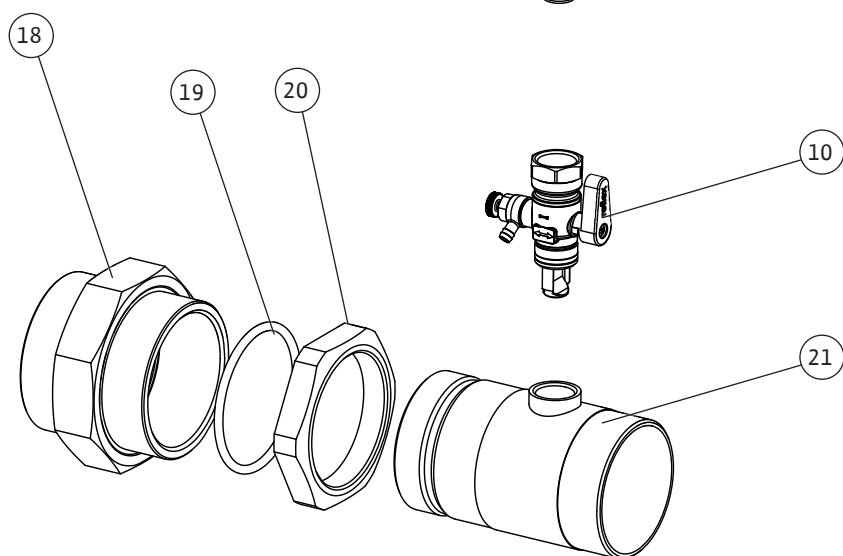
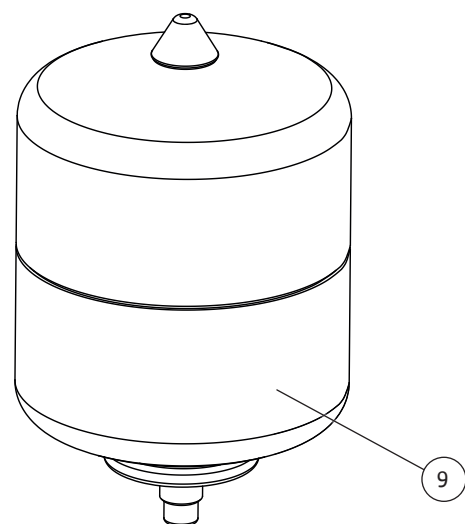
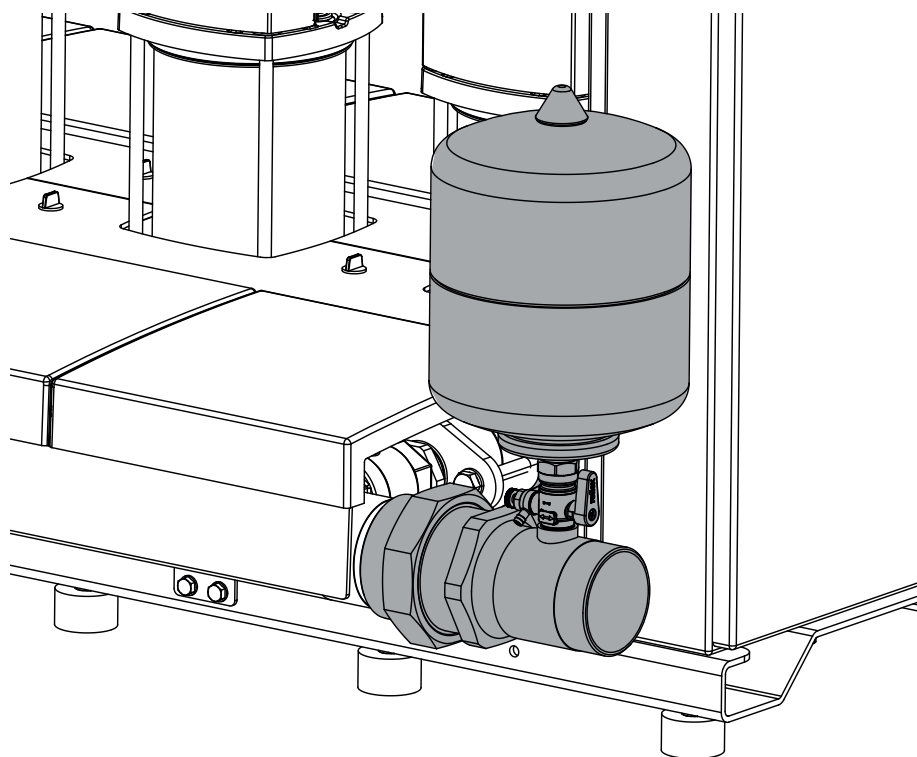

Fig. 6a

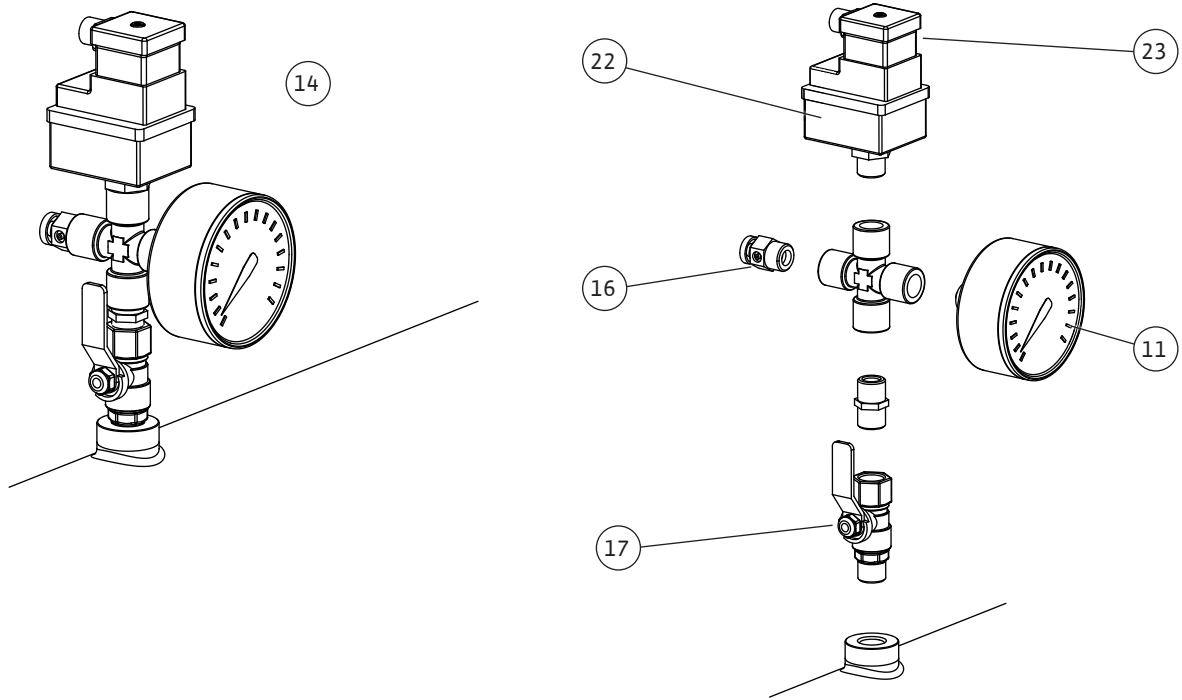

Fig. 6c

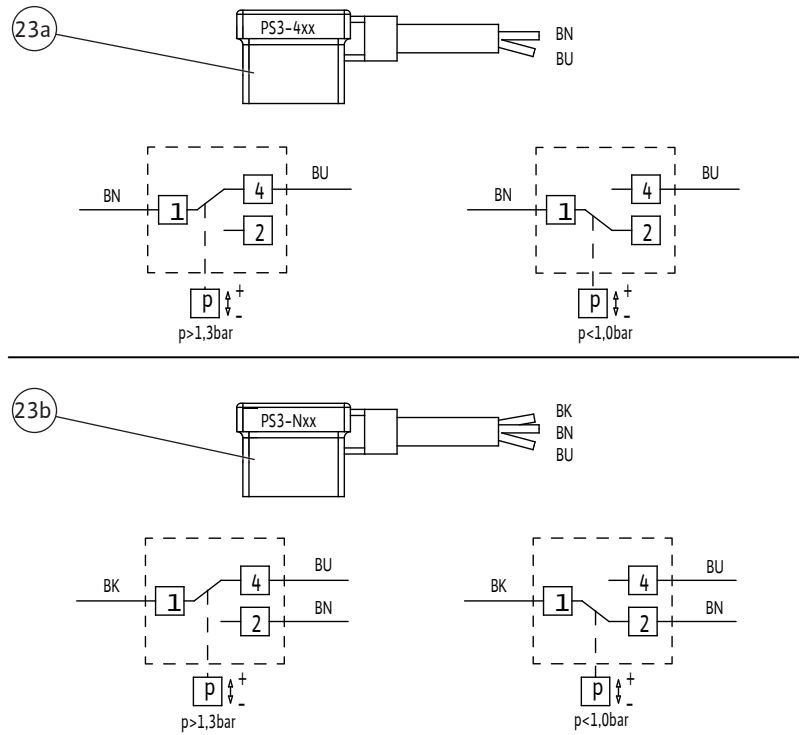
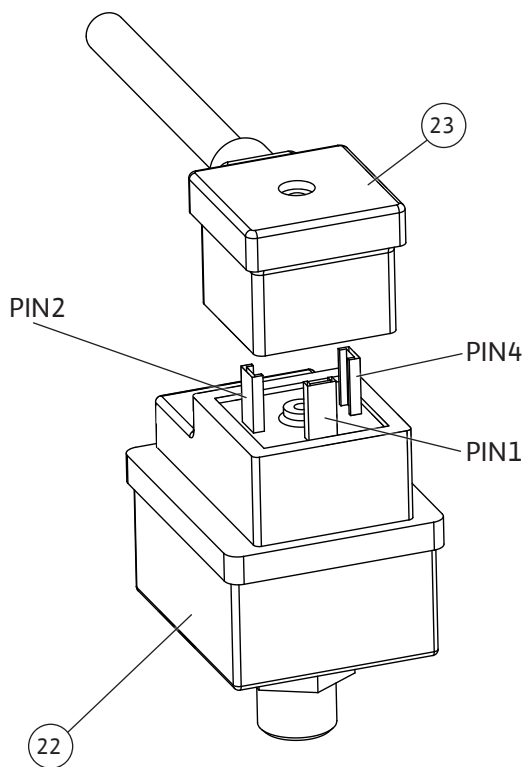

Fig. 6d

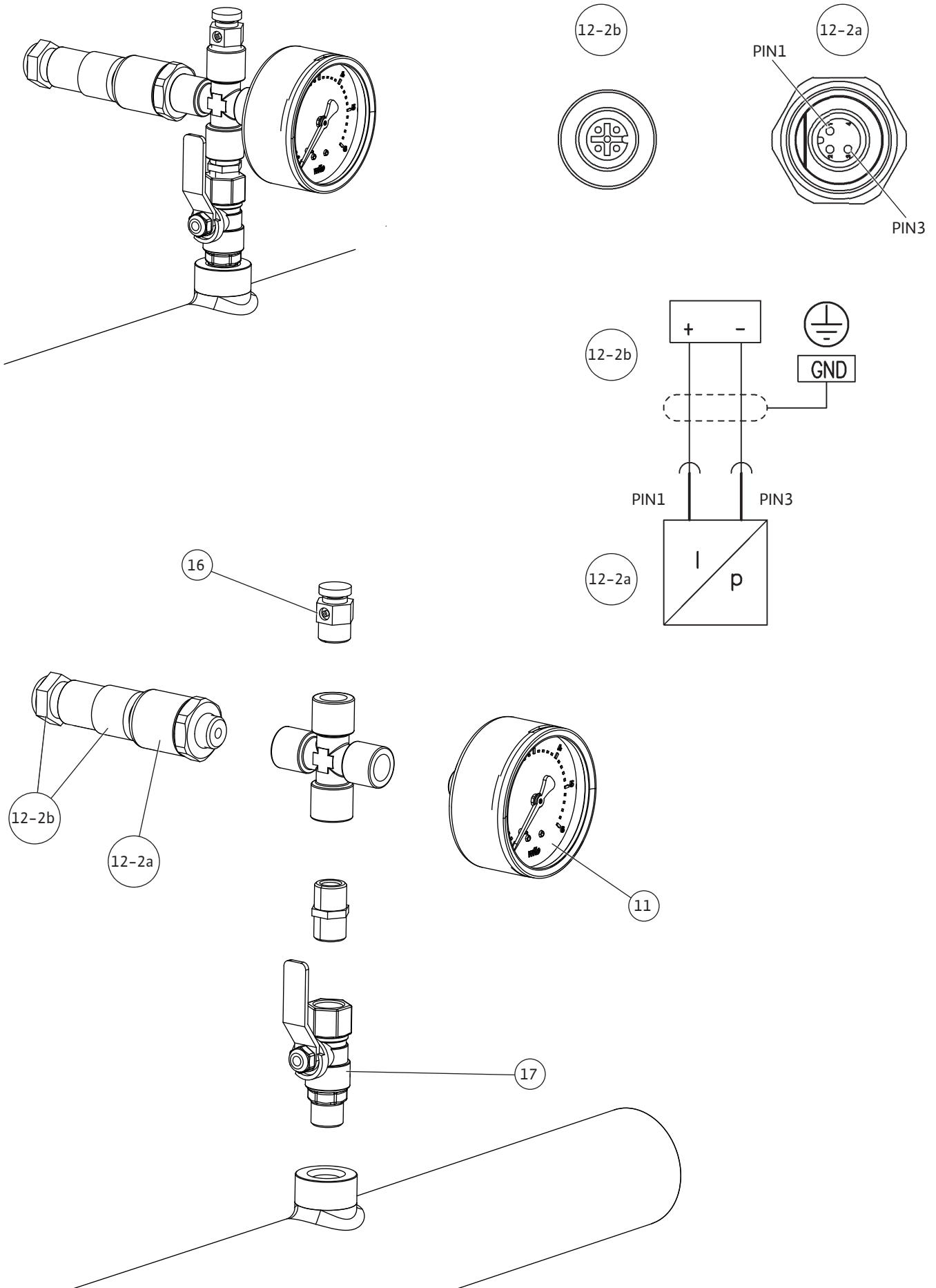

Fig. 6e

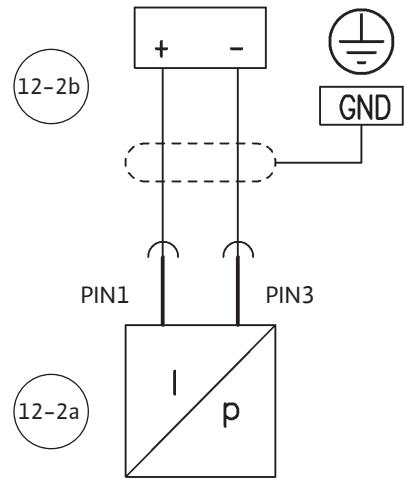
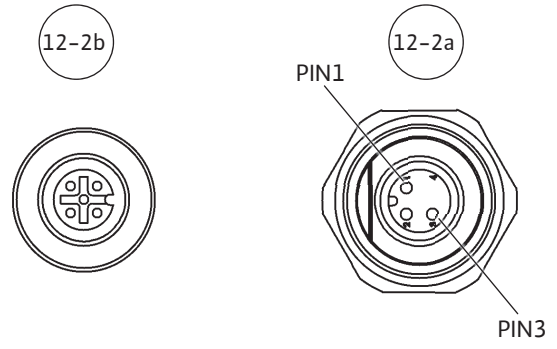
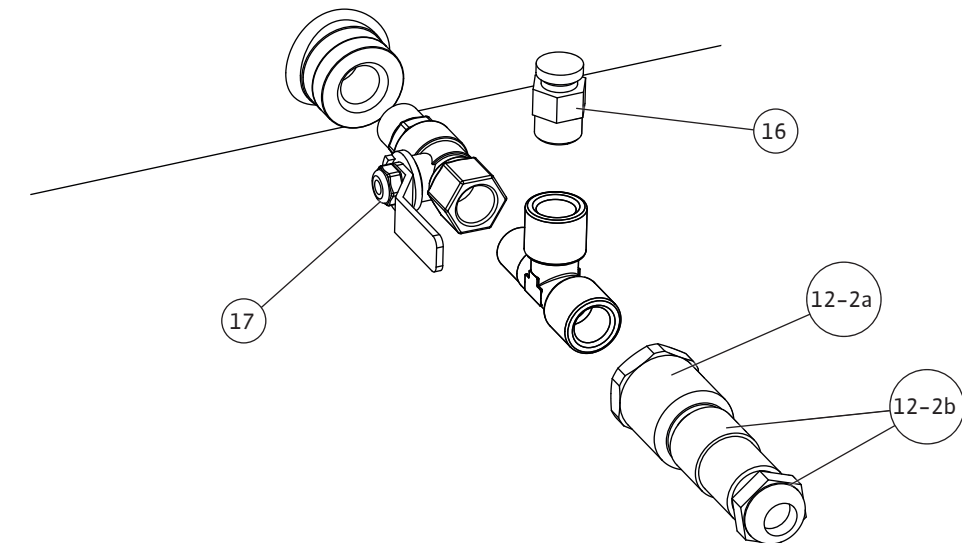
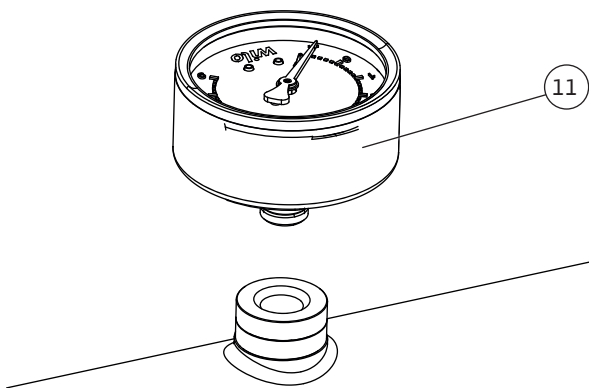
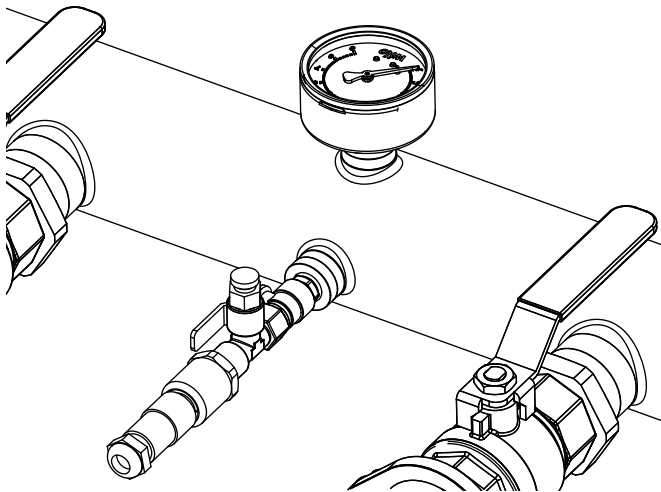

Fig. 6f

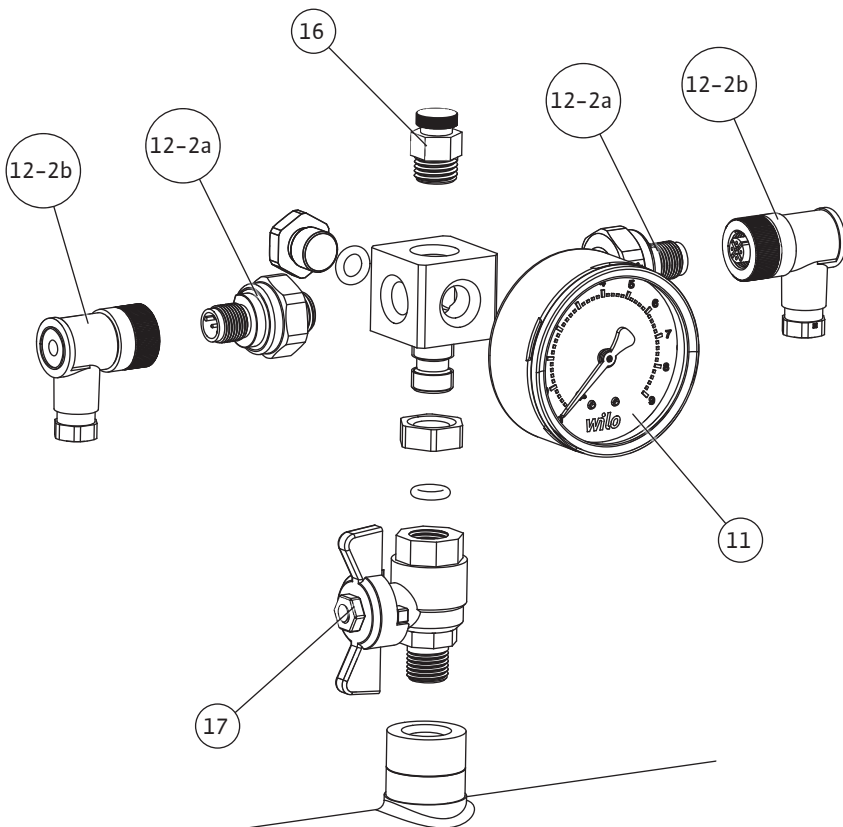
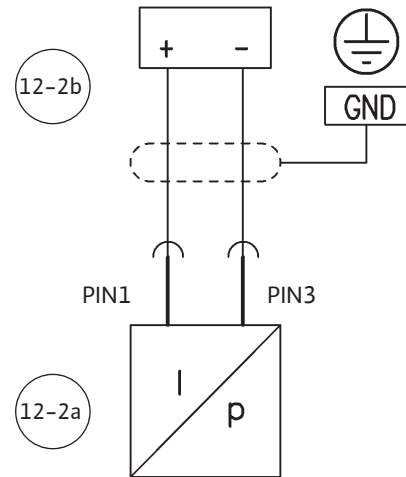
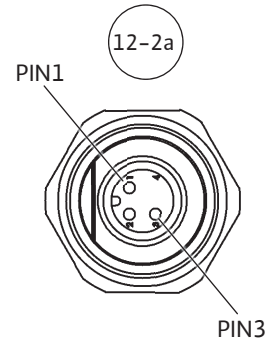
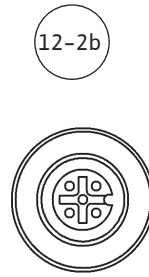
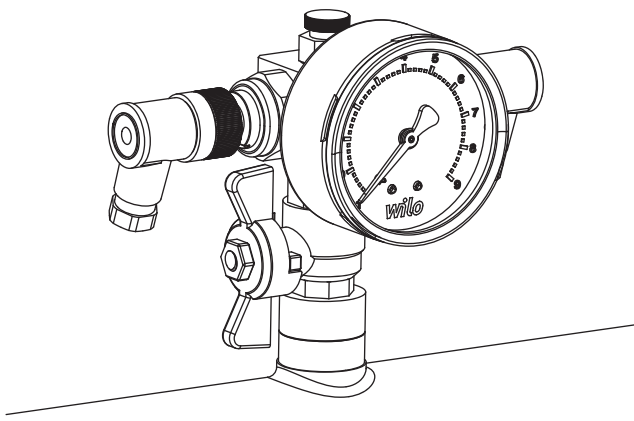

Fig. 7

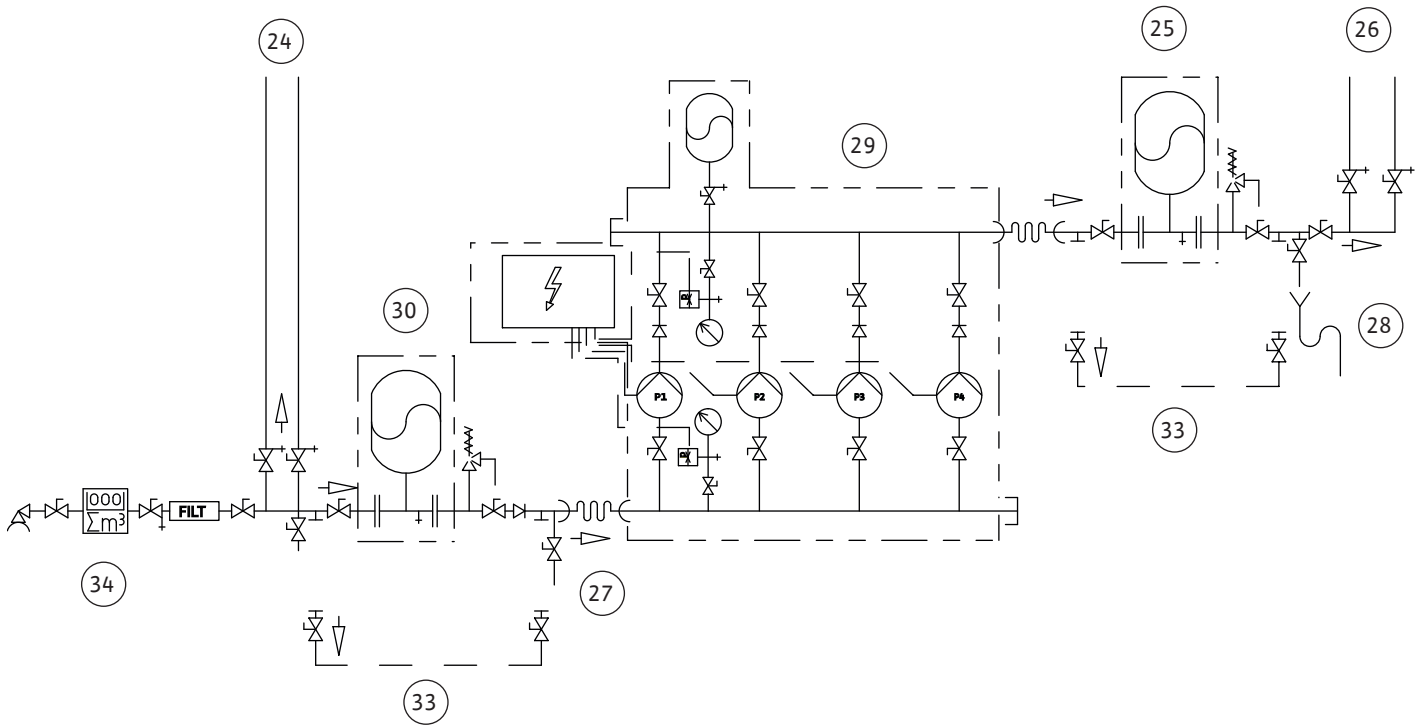

Fig. 8

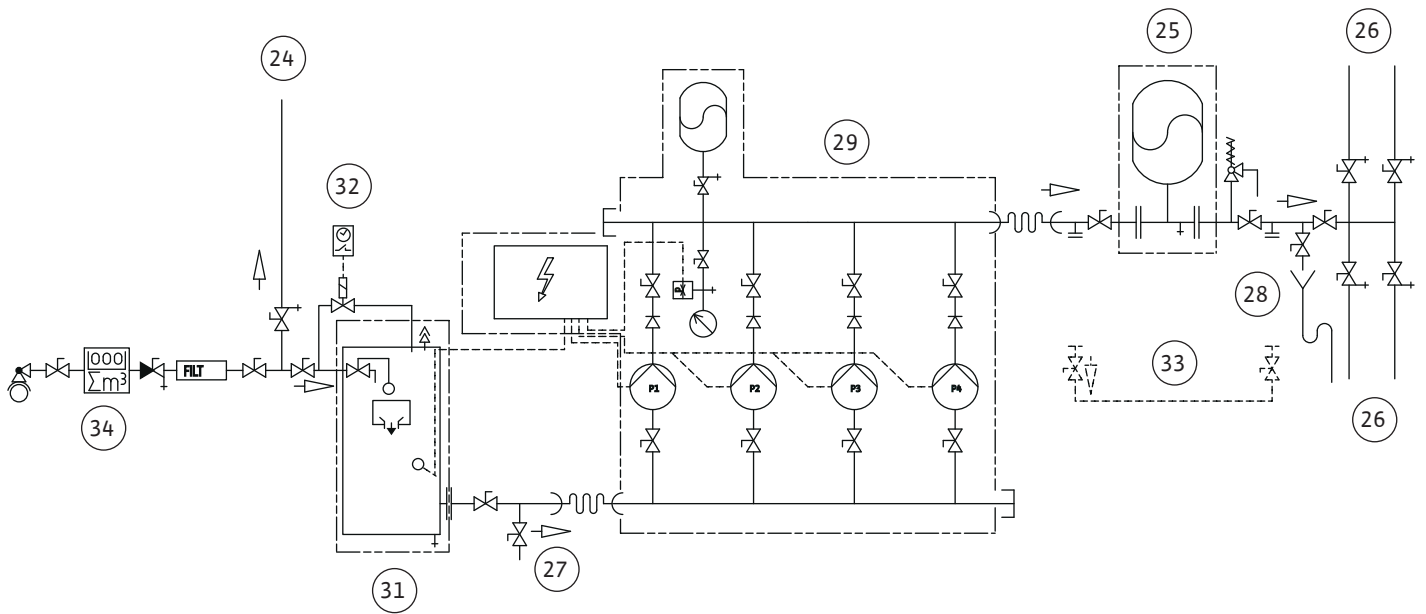

Fig. 9

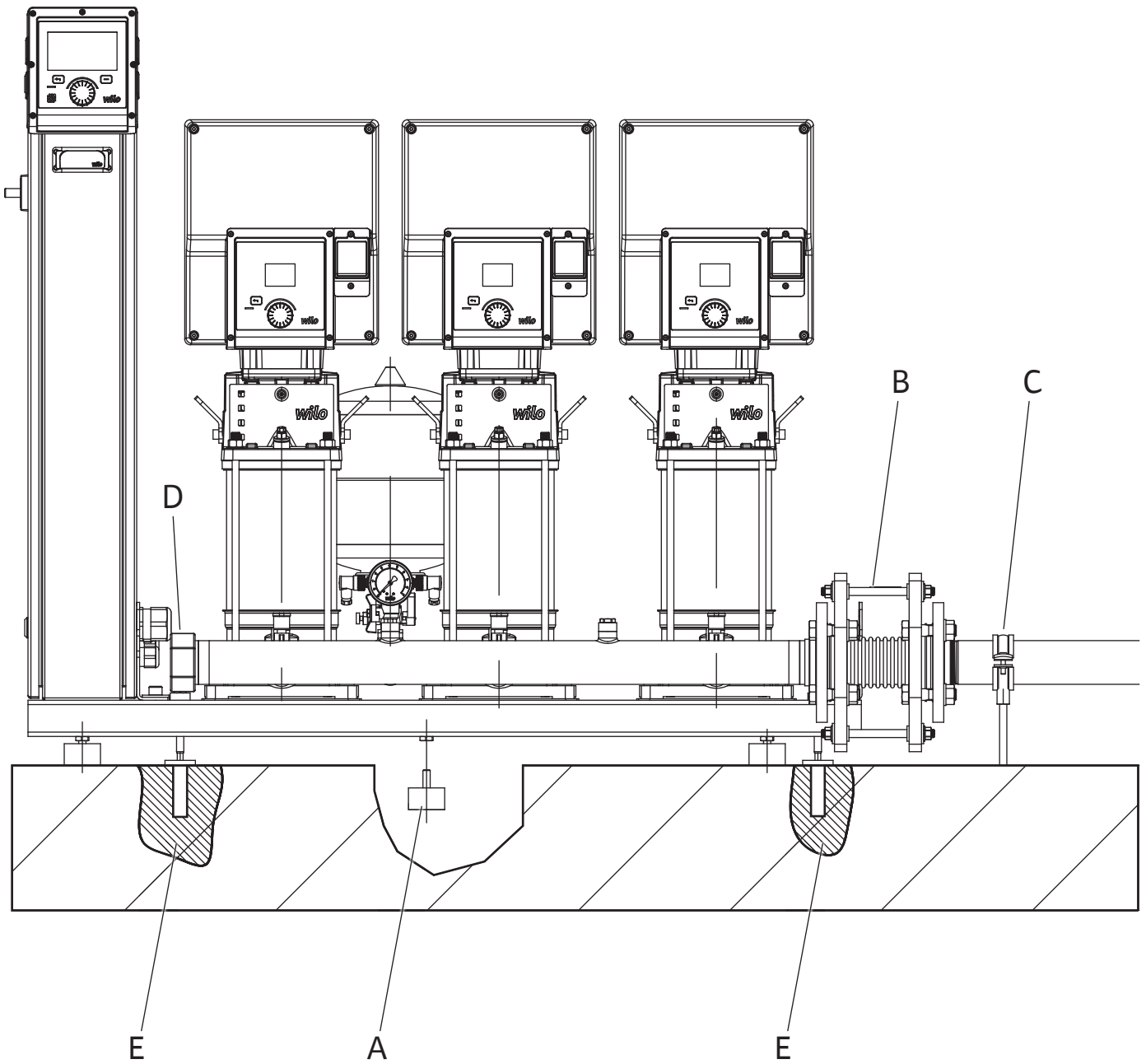

Fig. 10

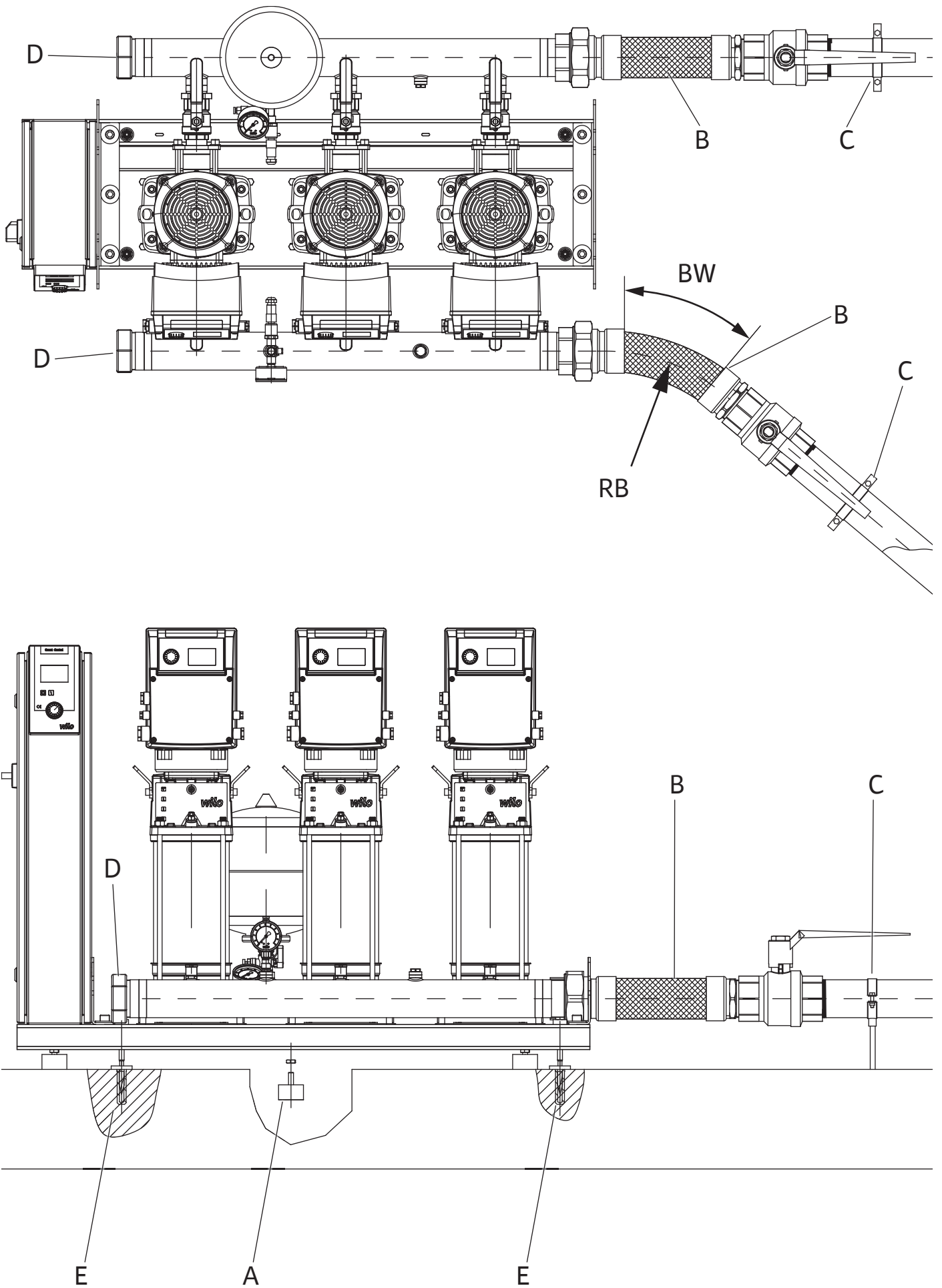

Fig. 11a

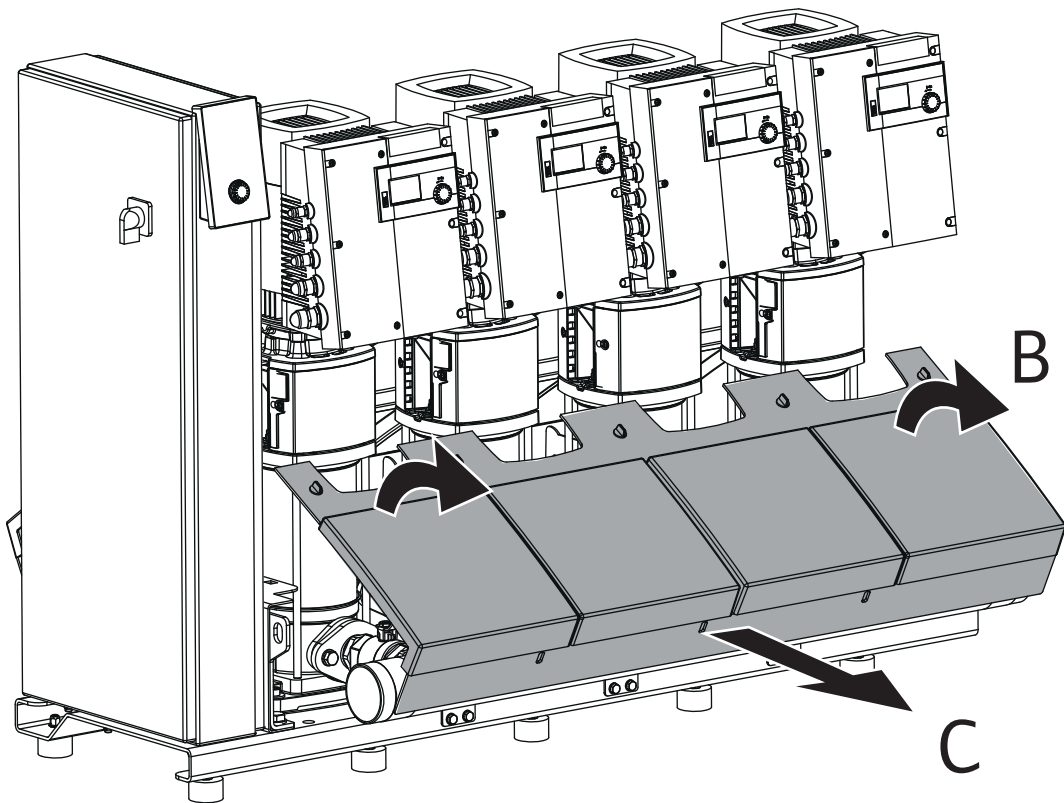
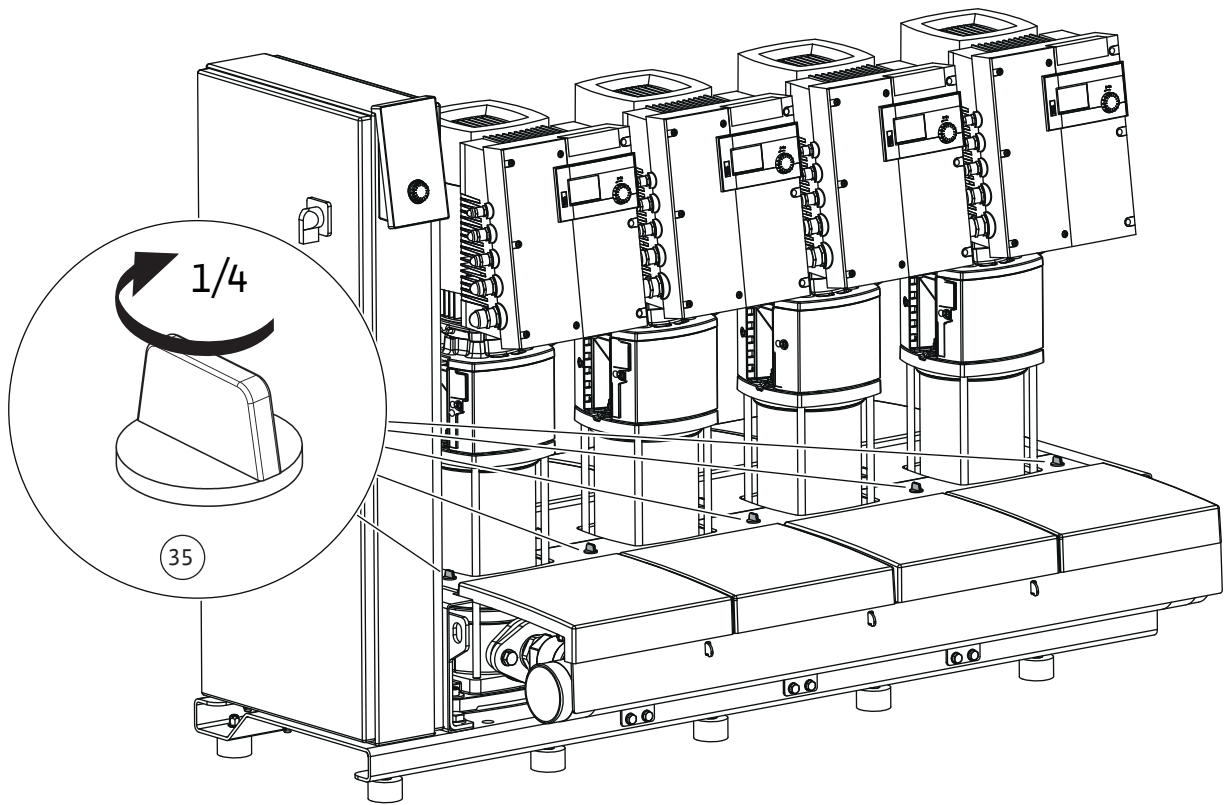

Fig. 11b

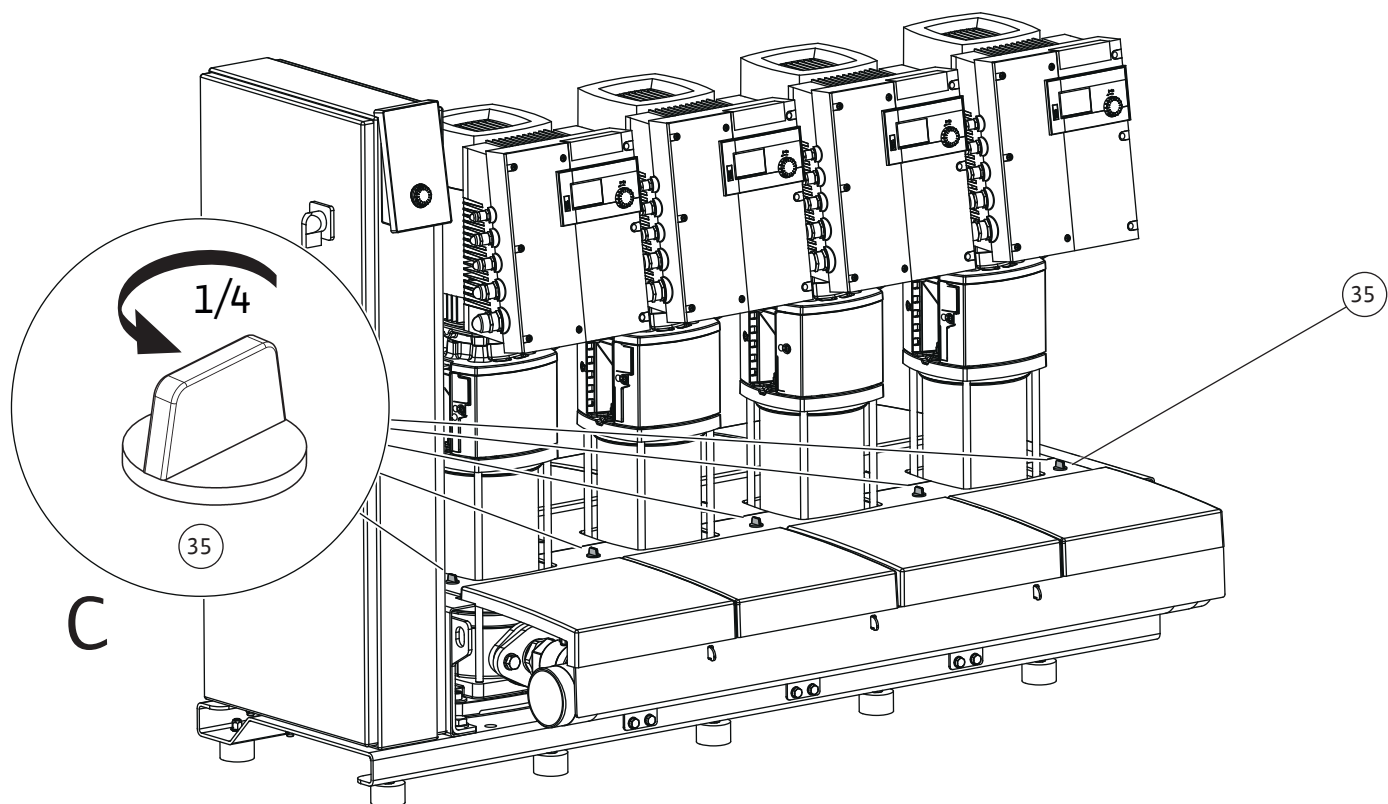
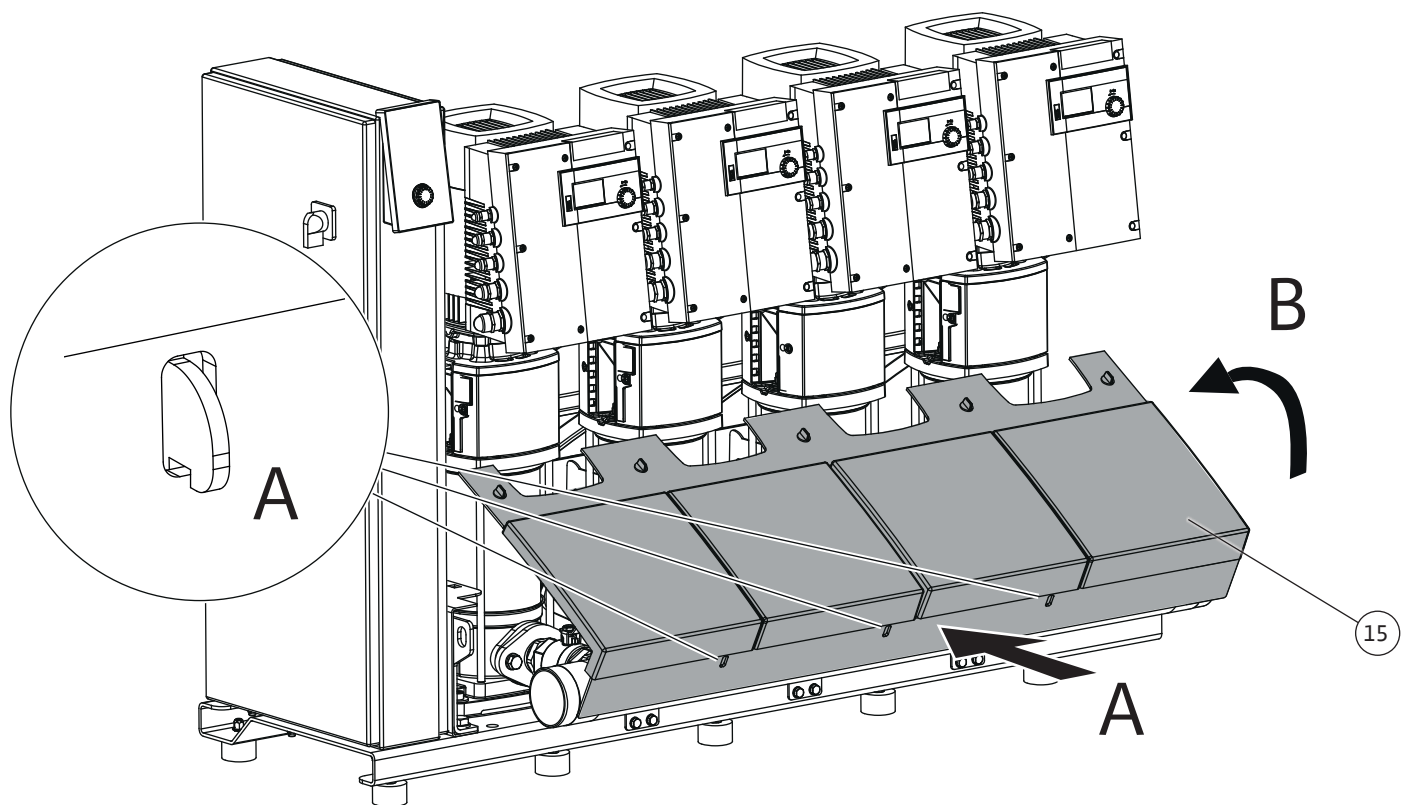

Fig. 12

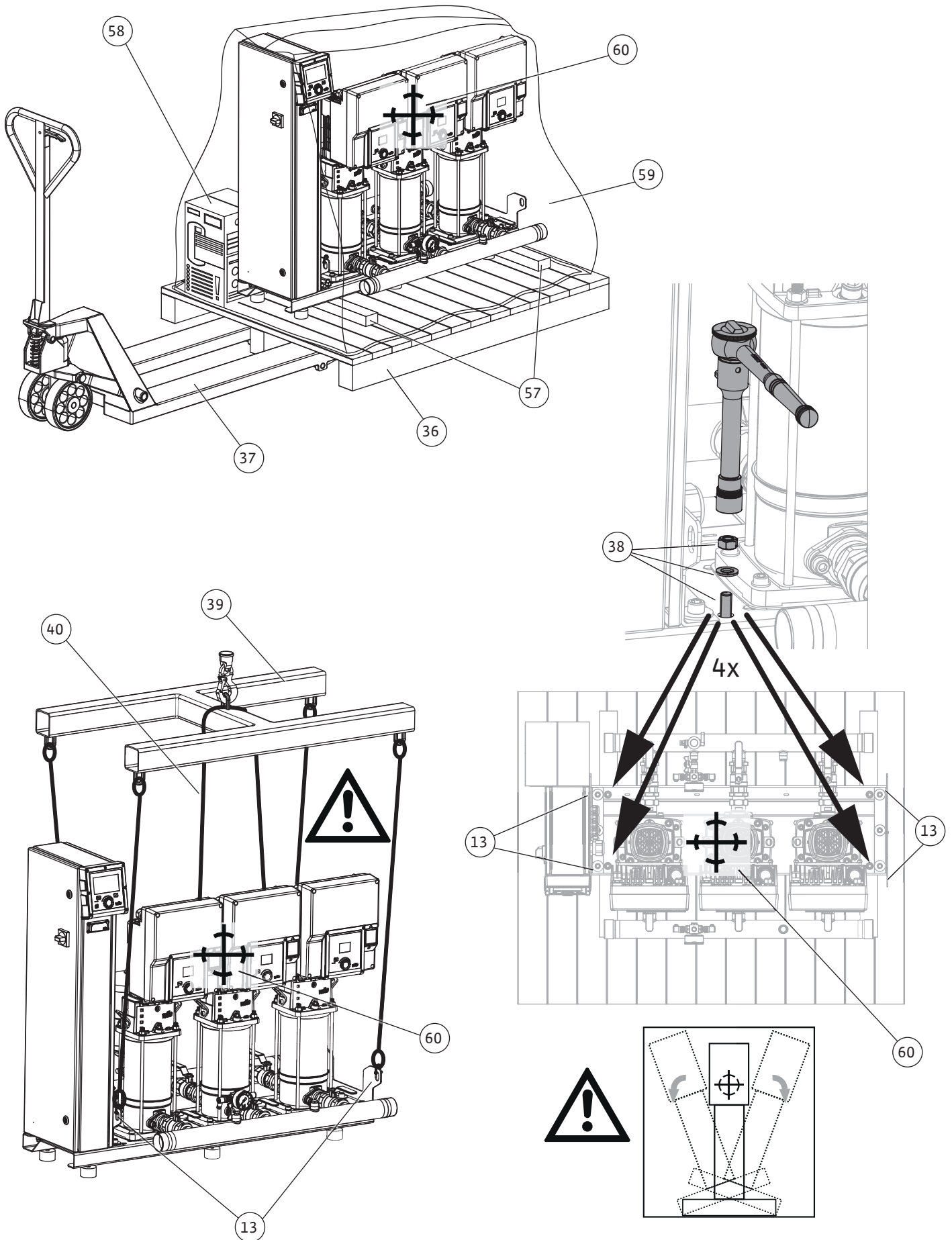

Fig. 13a

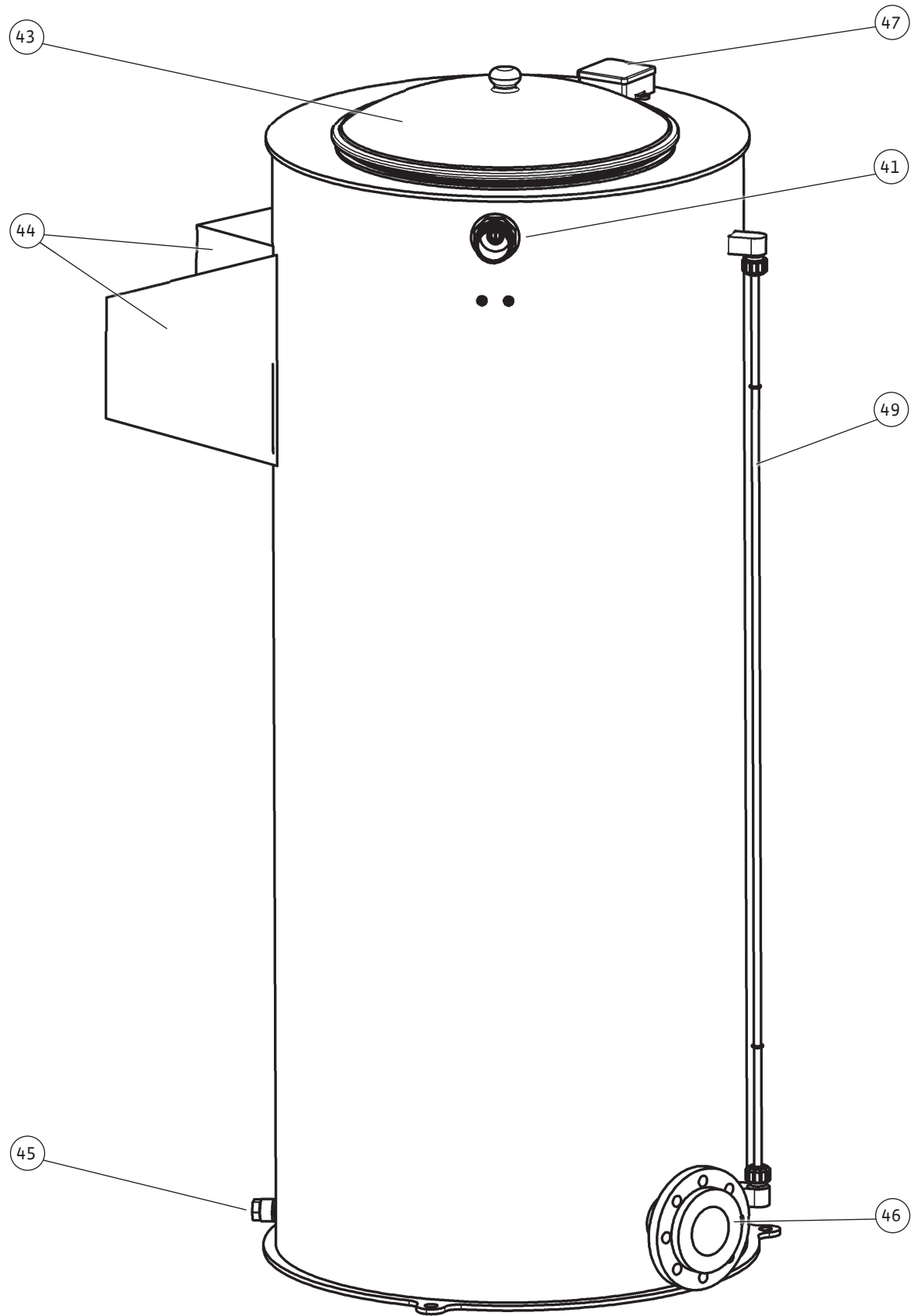

Fig. 13b

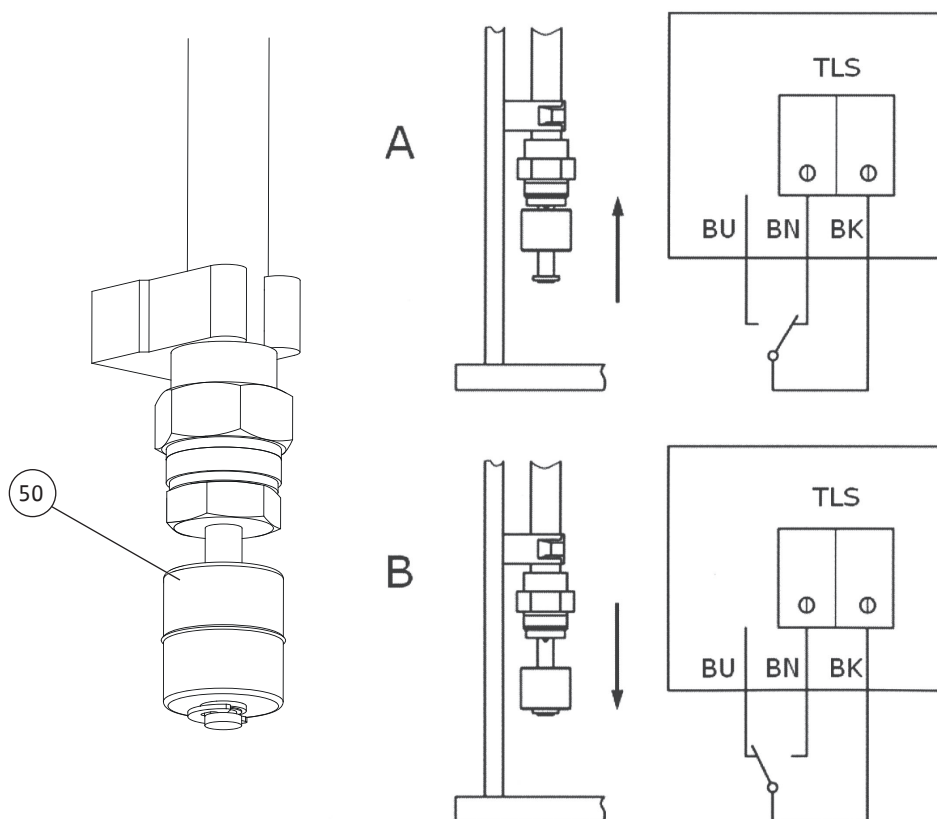

Fig. 14

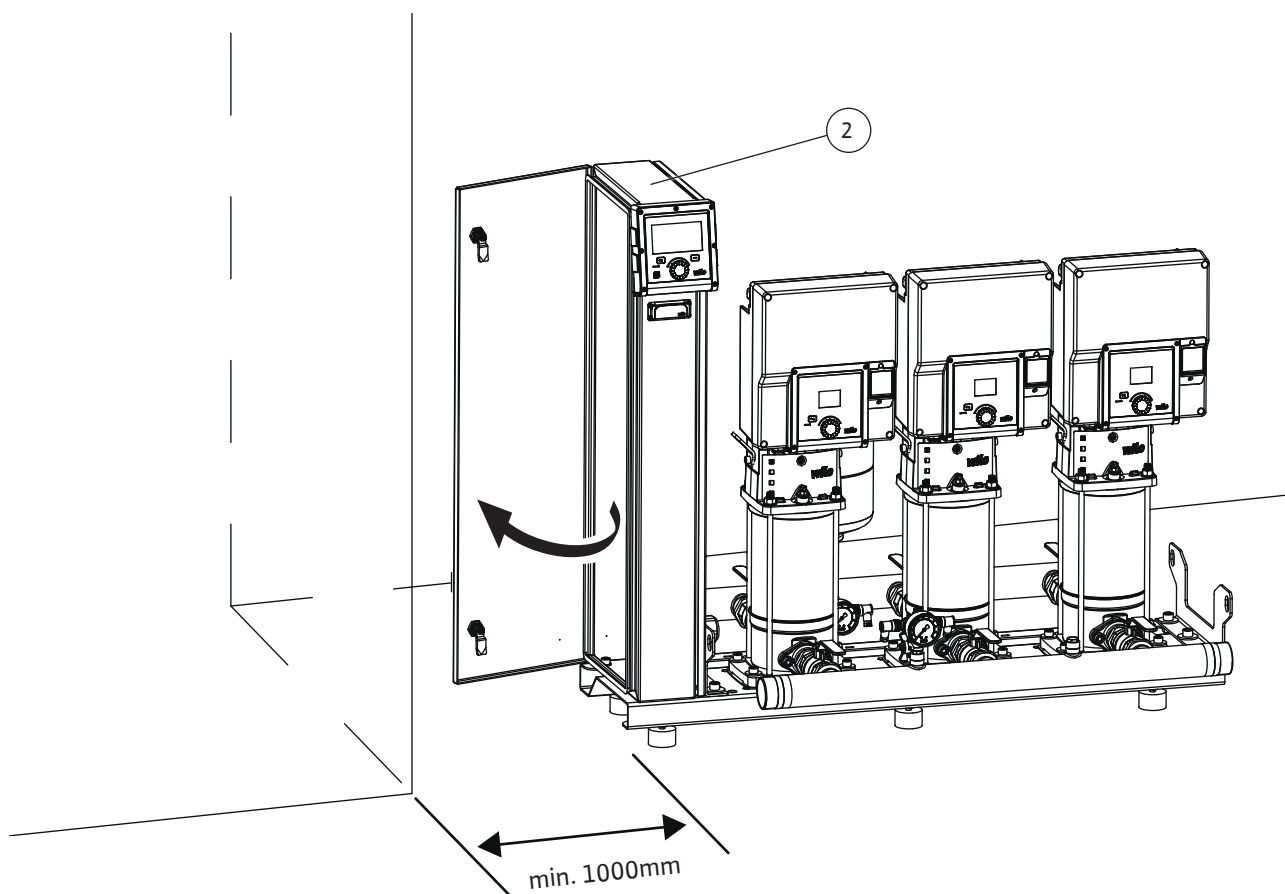

Table of Contents

1 General	24	12.5 Batteries/rechargeable batteries.....	55
1.1 About these instructions	24	13 Appendix	56
1.2 Copyright	24	13.1 Captions	56
1.3 Subject to change	24		
1.4 Exclusion from warranty and liability.....	24		
2 Safety	24		
2.1 Identification of safety instructions	24		
2.2 Personnel qualifications.....	26		
2.3 Electrical work	26		
2.4 Monitoring devices	26		
2.5 Transport.....	27		
2.6 Installing/dismantling.....	27		
2.7 During operation.....	27		
2.8 Maintenance tasks.....	28		
2.9 Operator responsibilities	28		
3 Application/use	29		
3.1 Intended use.....	29		
3.2 Improper use.....	29		
4 Product description	30		
4.1 Type key	30		
4.2 Technical data	31		
4.3 Scope of delivery.....	32		
4.4 Accessories	33		
4.5 Components of the system.....	33		
4.6 Function	35		
5 Transport and storage	39		
5.1 Delivery.....	40		
5.2 Transport.....	40		
5.3 Storage	41		
6 Installation and electrical connection	41		
6.1 Installation location.....	41		
6.2 Installation	41		
6.3 Electrical connection.....	47		
7 Commissioning	47		
7.1 Preparations and control measures.....	48		
7.2 Protection against low water level (WMS)	49		
7.3 Commissioning the system	50		
8 Shutdown/dismantling	50		
9 Maintenance	51		
9.1 Checking the pressure-boosting system.....	51		
9.2 Checking the supply pressure.....	51		
10 Faults, causes and remedies	51		
11 Spare parts	55		
12 Disposal	55		
12.1 Oils and lubricants	55		
12.2 Water-glycol mixture.....	55		
12.3 Protective clothing	55		
12.4 Information on the collection of used electrical and elec- tronic products.....	55		

1 General

1.1 About these instructions

These instructions form part of the product. Compliance with the instructions is essential for correct handling and use:

- Read the instructions carefully before all activities.
- Keep the instructions in an accessible place at all times.
- Observe all product specifications.
- Observe the markings on the product.

The language of the original operating instructions is German. All other languages of these instructions are translations of the original operating instructions.

1.2 Copyright

WILO SE © 2024

The reproduction, distribution and utilisation of this document in addition to communication of its contents to others without express consent is prohibited. Offenders will be held liable for payment of damages. All rights reserved.

1.3 Subject to change

Wilo shall reserve the right to change the listed data without notice and shall not be liable for technical inaccuracies and/or omissions. The illustrations used may differ from the original and are intended as an exemplary representation of the product.

1.4 Exclusion from warranty and liability

Wilo shall specifically not assume any warranty or liability in the following cases:

- Inadequate configuration due to inadequate or incorrect instructions by the operator or the client
- Non-compliance with these instructions
- Improper use
- Incorrect storage or transport
- Incorrect installation or dismantling
- Insufficient maintenance
- Unauthorised repairs
- Inadequate construction site
- Chemical, electrical or electrochemical influences
- Wear

2 Safety

This chapter contains basic information for the individual phases of the life cycle. Failure to observe this information carries the following risks:

- Injury to persons from electrical, mechanical and bacteriological factors as well as electromagnetic fields
- Environmental damage from discharge of hazardous substances
- Property damage
- Failure of important functions of the product

Failure to observe the information contained herein will result in the loss of claims for damages.

The instructions and safety instructions in the other chapters must also be observed!

2.1 Identification of safety instructions

These installation and operating instructions set out safety instructions for preventing personal injury and damage to property. These safety instructions are shown differently:

- Safety instructions relating to personal injury start with a signal word, are **preceded by a corresponding symbol** and are shaded in grey.



DANGER

Type and source of the danger!

Consequences of danger and instructions for avoidance.

- Safety instructions relating to property damage start with a signal word and are displayed **without** a symbol.

CAUTION

Type and source of the danger!

Consequences or information.

Signal words

- **DANGER!**
Failure to follow the instructions will result in serious injuries or death!
- **WARNING!**
Failure to follow the instructions can lead to (serious) injury!
- **CAUTION!**
Failure to follow the instructions can lead to potentially irreparable property damage as well as to total loss.
- **NOTICE!**
Useful information on handling the product

Markups

- ✓ Prerequisite
- 1. Work step/list
 - ⇒ Notice/instructions
 - ▶ Result

Symbols

These instructions use the following symbols:



General danger symbol



Danger caused by electric voltage



General warning symbol



Warning – suspended loads



Personal protective equipment: wear a safety helmet



Personal protective equipment: wear hearing protection



Personal protective equipment: wear safety footwear



Personal protective equipment: Wear protective gloves



Useful information

2.2 Personnel qualifications

- Personnel have been instructed on locally applicable regulations governing accident prevention.
- Personnel have read and understood the installation and operating instructions.
- Electrical work: qualified electrician
Person with appropriate technical training (according to EN 50110-1), knowledge and experience who can identify and prevent electrical hazards.
- Lifting work: trained specialist for the operation of lifting devices
Lifting equipment, lifting gear, attachment points
- Installation/dismantling must be carried out by a qualified technician who is trained in the use of the necessary tools and fixation materials.
- Operation/control: Operating personnel, instructed in the functioning of the complete system

2.3 Electrical work

- Observe applicable local regulations when connecting to the mains power supply.
- Comply with the requirements of the local energy supply company.
- Have electrical work carried out by a qualified electrician.
- Earth the device.
- Carry out the electrical connection according to the instructions of the switchgear and control device.
- Train personnel on how to make electrical connections.
- Train personnel on the options for switching off the device.
- Disconnect device from the mains and secure it against being switched on again without authorisation.
- Replace defective connection cables. Contact customer service.

2.4 Monitoring devices

The following monitoring devices must be provided by the customer if the system's scope of delivery does not include a switch cabinet:

Circuit breaker

- Design the power and switching characteristics of the circuit breakers according to the rated current of the connected product.

- Observe local regulations.

Motor protection switch

- Product without plug: install a motor protection switch!
The minimum requirement is a thermal relay/motor protection switch with temperature compensation, differential trip and re-activation lock according to local regulations.
- Instable mains supply systems: if necessary, install further protective devices on-site (e.g. overvoltage, undervoltage or phase failure relays, etc.).

Install the following monitoring device additionally on-site:

Residual-current device (RCD)

- Install a residual-current device (RCD) in accordance with the regulations of the local energy supply company.
- If people can come into contact with the device and conductive fluids, install a residual-current device (RCD).
- For systems/pumps with frequency converters, use a universal-current-sensitive residual-current device (type B RCD).

2.5 Transport

- Wear the following protective equipment:
 - Safety footwear
 - Safety helmet (when using lifting equipment)
- Locally applicable laws and regulations on work safety and accident prevention must be complied with.
- Only use legally prescribed and approved lifting and hoisting gear.
- Select the lifting gear based on the prevailing conditions (weather, attachment point, load, etc.).
- Always attach the lifting gear to the attachment points.
- Ensure that the lifting gear is securely attached.
- Ensure that the hoisting gear is stable.
- Ensure a second person is present to coordinate the procedure if required (e.g. if the operator's field of vision is blocked).
- Standing under suspended loads is not permitted. Do **not** move suspended loads over workplaces where people are present.

2.6 Installing/dismantling

- Wear the following protective equipment:
 - Safety footwear
 - Safety gloves for protection against cuts
- Locally applicable laws and regulations on work safety and accident prevention must be complied with.
- Disconnect device from the mains and secure it against being switched on again without authorisation.
- All rotating parts must stop.
- Clean the device thoroughly.

2.7 During operation

- Wear protective equipment according to work regulations.

- Demarcate and cordon off the working area.
- No persons are allowed in the working area during operation.
- Depending on the process, the product is activated and deactivated using separate controls. Product may automatically activate following power cuts.
- Superior must be informed immediately of any faults or irregularities.
- Operator must switch product off immediately if faults occur.
- Open all gate valves in the inlet and pressure pipe.
- Ensure protection against dry running.

2.8 Maintenance tasks

- Wear the following protective equipment:
 - Safety footwear
 - Safety gloves for protection against cuts
- Disconnect device from the mains and secure it against being switched on again without authorisation.
- Ensure cleanliness, dryness and good lighting in the work area.
- Only carry out maintenance tasks described in these installation and operating instructions.
- Only original parts of the manufacturer may be used. The use of any non-original parts releases the manufacturer from any liability.
- Collect any leakage of fluid and operating fluid immediately and dispose of it according to the locally applicable guidelines.
- Clean the device thoroughly.

2.9 Operator responsibilities

- Provide installation and operating instructions in a language which the personnel can understand.
- Make sure that the personnel have received the required training for the specified work.
- Provide protective equipment. Ensure that the protective equipment is worn by personnel.
- Ensure that safety and information signs mounted on the device are always legible.
- Train the personnel on how the system operates.
- Eliminate any risk from electrical current.
- Demarcate and cordon off the working area.
- Define a personnel work plan for safe workflow.
- Carry out a sound pressure measurement. From a sound-pressure level of 85 dB(A) upward, wear hearing protection. Include a note in the work regulations!

Observe the following points when handling the device:

- Use is not permitted for persons under the age of 16.
- Persons under the age of 18 must be supervised by a technician!

- Use is not permitted for persons with limited physical, sensory or mental capacities!

3 Application/use

3.1 Intended use

Function and application

The Wilo pressure-boosting systems of the SiBoost Smart series are designed for water supply systems for pressure boosting and pressurisation.

The system is used as:

- Drinking water installation, primarily in high-rise apartments, hospitals, administrative and industrial buildings, the structure, function and requirements of which comply with the following standards, guidelines and directives:
 - DIN 1988 (for Germany)
 - DIN 2000 (for Germany)
 - EU Directive 98/83/EC
 - Drinking Water Ordinance in its valid version (for Germany)
 - DVGW directives (for Germany)
- Industrial system for water supply and cooling systems
- Fire water and supply system for local use
- Irrigation and sprinkling installation

Current design, installation and application instructions for Wilo pressure-boosting systems can be found in the Wilo manual “Tips and tricks Booster” and other Wilo manuals and brochures on pump and system technology, see: <https://wilo.com>.

For your safety

Intended use includes:

- Completely reading and following all instructions in these Installation and operating instructions.
- Observing the statutory accident prevention and environmental regulations.
- Complying with inspection and maintenance regulations.
- Complying with in-house regulations and instructions.

The pressure-boosting system is built according to the manufacturer’s specifications as well as the state of the art and the recognised safety regulations. However, in the event of incorrect operation or misuse, danger to life and limb of the operator or third parties or damage to the system itself and other material assets may occur.

The safety devices on the pressure-boosting system are designed in such a way that there is no risk to the operating personnel when the system is used as intended.

The pressure-boosting system may only be used in technically fault-free condition and in accordance with its intended use, in a safety-conscious and hazard-conscious manner and in compliance with these installation and operating instructions. Faults that may affect safety must be rectified immediately by qualified personnel.

3.2 Improper use

Possible misuse

The pressure-boosting system is not designed for applications that are not explicitly intended for it by the manufacturer. This includes, in particular:

- Pumping fluids that chemically or mechanically attack the materials used in the system
- Pumping fluids that contain abrasive or long-fibre components
- Pumping fluids that are not intended for this purpose by the manufacturer

Persons under the influence of intoxicating substances (e.g. alcohol, drugs, narcotics) are not authorised to operate, maintain or modify the pressure-boosting system in any way.

Improper use

Improper use occurs when parts other than those specified in the intended use are processed in the pressure-boosting system. Modification of the components of the pressure-boosting system also leads to improper use.

All spare parts must comply with the technical requirements specified by the manufacturer. There is no guarantee that third-party parts are designed and manufactured in accordance with appropriate safety and operational requirements. This is always guaranteed when using original spare parts.

Modifications to the pressure-boosting system (mechanical or electrical changes to the function sequence) invalidate any liability on the part of the manufacturer for any resulting damage. This also applies to the installation and adjustment of safety devices and valves as well as the modification of load-bearing parts.

4 Product description

4.1 Type key

Example	Wilo-SiBoost Smart-2HELIX V605
Wilo	Brand name
SiBoost	Product family: pressure-boosting systems
Smart	Series designation
2	Number of pumps
HELIX	Pump series reference (see attached pump documentation)
-V	Pump design, vertical standard version
6	Rated volume flow Q [m ³ /h] per pump (2-pole - 50 Hz version)
05	Number of pump stages

Example	Wilo-SiBoost Smart-2HELIX V604/380-60
Wilo	Brand name
SiBoost	Product family: pressure-boosting systems
Smart	Series designation
2	Number of pumps
HELIX	Pump series reference (see attached pump documentation)
-V	Pump design, vertical standard version
6	Rated volume flow Q [m ³ /h] per pump (2-pole - 50 Hz version)
04	Number of pump stages
380	Mains rated voltage 380 V (3~)
60	Frequency, in this case 60 Hz

Example	Wilo-SiBoost Smart FC-3HELIX V1007
Wilo	Brand name
SiBoost	Product family: pressure-boosting systems
Smart	Series designation
FC	With built-in frequency converter (Frequency Converter) in the control device
3	Number of pumps
HELIX	Pump series reference (see attached pump documentation)
-V	Pump design, vertical standard version
10	Rated volume flow Q [m ³ /h] per pump (2-pole - 50 Hz version)
07	Number of pump stages

Example	Wilo-SiBoost2.0 Smart-4HELIX VE1603
Wilo	Brand name
SiBoost	Product family: pressure-boosting systems
2.0	Generation labelling
Smart	Series designation
4	Number of pumps
HELIX	Pump series reference (see attached pump documentation)
-VE	Pump design, vertical electronic version (with frequency converter)
16	Rated volume flow Q [m ³ /h] per pump (2-pole - 50 Hz version)
03	Number of pump stages

4.2 Technical data

Max. volume flow	see catalogue/data sheet	
Max. delivery head	see catalogue/data sheet	
Speed	<ul style="list-style-type: none"> • 2800 – 2900 rpm (fixed speed) HELIX V • 900 – 3600 rpm (variable speed) HELIX VE, MWISE • 3500 rpm (fixed speed) HELIX V, 60 Hz 	
Mains voltage	<ul style="list-style-type: none"> • 3~ 400 V ±10 % V (L1, L2, L3, PE) • 3~ 380 V ±10 % V (L1, L2, L3, PE), 60 Hz version 	
Rated current	See rating plate	
Frequency	<ul style="list-style-type: none"> • 50 Hz (Helix V, special version: 60 Hz) • 50/60 Hz (Helix VE, Helix EXCEL) 	
Electrical connection	(See installation and operating instructions and circuit diagram of the control device)	
Insulation class	F	
Protection class	IP54 (HELIX V; VE; EXCEL...)/IP44 (MWISE)	
Power consumption P ₁	See rating plate of pump/motor	
Power consumption P ₂	See rating plate of pump/motor	
Nominal diameters	R1½/R1½	(..2HELIX VE 2)
Connection		(..2MWISE 2)
Suction/discharge line		(..2HELIX V/VE/EXCEL 4)
		(..3HELIX VE 2)
		(..3HELIX V 4)
		(..2HELIX V 4.. (60 Hz))
	R2/R2	(..2HELIX V/VE/EXCEL 6)
		(..2MWISE 4)
		(..3MWISE 2)
		(..3HELIX VE/EXCEL 4)
		(..4MWISE 2)
		(..4HELIX VE 2)
		(..4HELIX V 4)
		(..2HELIX V 6..(60 Hz))
		(..3HELIX V 4...(60 Hz))
	R2½/R2½	(..2MWISE 8)
		(..2HELIX V/VE/EXCEL 10)
		(..2HELIX V 16)
		(..3MWISE 4)
		(..3HELIX V/VE/EXCEL 6)
		(..3HELIX V/VE/EXCEL 10)
		(..4MWISE 4)
		(..4HELIX VE/EXCEL 4)
		(..4HELIX V/VE/EXCEL 6)
		(..2HELIX V 10..(60 Hz))
		(..3HELIX V 6..(60 Hz))
		(..3HELIX V 10..(60 Hz))
		(..4HELIX V 4..(60 Hz))
		(..4HELIX V 6..(60 Hz))

	R3/R3	(..2HELIX VE/EXCEL 16) (..2HELIX V/VE/EXCEL 22) (..3MWISE 8) (..3HELIX V 16) (..4MWISE 8) (..4HELIX V/VE/EXCEL 10) (..2HELIX V 16..(60 Hz)) (..4HELIX V 10..(60 Hz))
	DN 100/DN 100	(..2HELIX V/VE/EXCEL 36) (..3HELIX VE/EXCEL 16) (..3HELIX V/VE/EXCEL 22) (..4HELIX V/VE/EXCEL 16) (..3HELIX V 16..(60 Hz)) (..4HELIX V 16..(60 Hz))
	DN 125 /DN 125	(..2HELIX V/VE/EXCEL 52) (..3HELIX V/VE/EXCEL 36) (..4HELIX V/VE/EXCEL 22)
	DN 150 /DN 150	(..3HELIX V/VE/EXCEL 52) (..4HELIX V/VE/EXCEL 36)
	DN 200 /DN 200	(..4HELIX V/VE/EXCEL 52)
	(Subject to change without prior notice/see also the installation plan provided)	
Permitted ambient temperature	5 °C to 40 °C	
Permissible fluids	Pure water without settling sediments	
Permissible fluid temperature	3 °C to 50 °C (deviating values on request)	
Max. permissible operating pressure	On the pressure side 16 bar (see rating plate)	
Max. permissible inlet pressure	Indirect connection (but max. 6 bar)	
Diaphragm pressure vessel	Total volume: 8 l	

4.3 Scope of delivery

The automatically controlled Wilo pressure–boosting systems SiBoost Smart are supplied ready for connection.

As a compact unit with integrated control, they contain 2 to 4 non–self–priming, vertical high–pressure multistage centrifugal pumps.

The pumps are mounted on a common base frame and completely piped together.

Measures required on–site:

- Make the connections for the inlet and pressure pipes.
- Establish the electrical mains connection.
- Install the supplied accessories ordered separately.

4.3.1 Standard version scope of delivery

- Pressure–boosting system
- Installation and operating instructions for the pressure–boosting system
- Installation and operating instructions for the pumps
- Installation and operating instructions for the control device
- Factory test protocol

4.3.2 Special version scope of delivery

- Installation plan, if applicable
- Electrical circuit diagram, if applicable
- Installation and operating instructions for the frequency converter, if applicable
- Supplementary sheet with the factory settings for the frequency converter, if applicable
- Installation and operating instructions for the signal transmitter, if applicable

4.4 Accessories

- Spare parts list, if applicable

Accessories must be ordered separately as required. The accessories from the Wilo range include the following:

- Open break tank (Fig. 13a)
- Larger diaphragm pressure vessel (on the supply or end pressure side)
- Safety valve
- Dry-running protection:
 - For systems with frequency control on each pump (HELIX VE, HELIX EXCEL, MWISE): For operation with supply pressure, a pressure sensor or two pressure sensors (SiBoost 2.0) are fitted on the suction side as standard that function as a low-water cut-out switchgear (Fig. 6d, 6e or 6f).
 - On systems without frequency converter (HELIX V), which are operated with supply pressure (inlet mode, supply pressure of at least 1 bar), a separate assembly is ready fitted as a dry-running protection (WMS) (Fig. 6a and 6c) if it is included in the order scope.
 - Float switch
 - Low-water electrodes with a level relay
 - Electrodes for tank operation (special accessories on request)
- Flexible connection cables (Fig. 10 – Item B),
- Compensators (Fig. 9 – Item B),
- Threaded flanges and caps (Fig. 9, 10 – Item D)
- Sound-insulating unit casing (special accessories on request)

4.5 Components of the system



NOTICE

These installation and operating instructions contain a general description of the complete system.



NOTICE

For detailed information about the pump in this pressure-boosting system, see the enclosed installation and operating instructions for the pump.

4.5.1 Connection

The pressure-boosting system with a non-self-priming high-pressure multistage centrifugal pump can be connected to the public water supply network for drinking water in two ways:

- Direct connection: without system separation (Fig. 7).
- Indirect connection: connection is established with system separation through a closed and unpressurised break tank (atmospheric pressure) (Fig. 8).

4.5.2 Components of the pressure-boosting system

The complete system is made up of various main components.



NOTICE

Observe the respective installation and operating instructions for the individual component.

Mechanical and hydraulic components (Fig. 1a, 1b, 1c, 1d, 1e, 1f)

The compact unit is installed on a base frame with vibration absorbers (Item 3). It consists of a group of 2 to 4 high-pressure multistage centrifugal pumps (Item 1), which are combined by means of an inlet collecting pipe (Item 4) and a pressure collecting pipe (Item 5) to form a complete system. Each pump is fitted with a shut-off valve on the inlet side (Item 6), a shut-off valve on the discharge side (Item 7) and a non-return valve (Item 8) on the discharge side.

An assembly with isolation valves is fitted on the pressure collecting pipe, which includes one pressure sensor (Item 12-1) or two pressure sensors (SiBoost2.0) and one pressure gauge (Item 11) (also see Fig. 2a, 2b and 2c).

For systems with pumps of the MWISE, HELIX V and HELIX VE series, an 8-litre diaphragm pressure vessel (Item 9) with a lockable throughflow fitting (Item 10) (for flow through according to DIN 4807 – part 5) (see also Fig. 3) is fitted to the pressure collecting pipe (Item 5).

For systems with pumps of the HELIX EXCEL series a kit with an 8-litre diaphragm pressure vessel is fitted (see Fig. 5).

For systems with a frequency converter on each pump (HELIX VE, HELIX EXCEL, MWISE), an additional assembly with isolation valves is fitted on the inlet collecting pipe as standard, which includes one pressure sensor (Item 12-2) or two pressure sensors (SiBoost2.0) and one pressure gauge (Item 11) (also see Fig. 6d, 6e and 6f).

For systems without a frequency converter on each pump, an assembly for a low-water cut-out switchgear (WMS) (Item 14) can optionally be fitted or mounted at a later date at the inlet collecting pipe (see Fig. 6a and 6c).

The control device (Item 2) is mounted directly on the base frame and wired to the electrical components of the system.

In the case of higher performance systems, the control device is mounted in a separate free-standing cabinet (BM). The electrical components are pre-wired to the corresponding connection cable. For the separate free-standing cabinet (BM), the final wiring is to be carried out by the customer (see section 6.3 and the documentation included with the control device).

Systems with pumps of the HELIX EXCEL series: (except pumps 52 etc.) are additionally equipped with a unit casing (Fig. 1c – Item 15a and 15b) around the valves and manifold.

High-pressure multistage centrifugal pumps (Item 1): Different types of high-pressure multistage centrifugal pumps are installed in the pressure-boosting system depending on the application and the performance parameters required. Their number can vary from 2 to 4 pumps. Pumps with built-in frequency converters (HELIX VE, HELIX EXCEL or MWISE) or without built-in frequency converters (HELIX V) are used. Information about the pumps can be found in the attached installation and operating instructions.



NOTICE

For detailed information about the pump in this pressure-boosting system, see the enclosed installation and operating instructions for the pump.

Control device (Fig. 1a, 1b, 1c, 1d, 1e – Item 2)

The control device of the Wilo Smart Control SC series is used to control and regulate the SiBoost Smart pressure-boosting system. The size and components of the control device may vary depending on the design and performance parameters of the pumps. For information on the control device, see the enclosed installation and operating instructions and the circuit diagram.

Diaphragm pressure vessel kit (Fig. 3, Fig. 5)

- Diaphragm pressure vessel (Item 9) with flow-through fixture that can be shut off (Item 10)

Pressure sensor kit on the discharge side (Fig. 2a, 2b, 2c) and pressure sensor kit on the inlet side (Fig. 6d, 6e, 6f) for systems with frequency converter on each pump (HELIX VE, HELIX EXCEL, MWISE):

- Pressure gauge (Item 11)
- Pressure sensor (on the discharge side: Item 12-1a, on the inlet side: Item 12-2a)
- Electrical connection, pressure sensor (on the discharge side: Item 12-1b, on the inlet side: Item 12-2b)
- Drain/venting (Item 16)
- Stop valve (Item 17)

4.6 Function



WARNING

Risk of damage to your health!

Risk of damage to your health due to contaminated drinking water.

- Use only materials that ensure the required water quality for drinking water installations.
- To reduce any impairment of the drinking water quality, flush the pipes and system.
- If commissioning the system after a longer period of downtime, replace the water.

CAUTION

Risk of damage to property!

Dry running can lead to the pump developing leakages and to motor overload.

- Ensure that the pump does not run dry to protect the mechanical seal and the plain bearings.

4.6.1 Description

The Wilo pressure-boosting system of the SiBoost Smart series is supplied ready for connection as a compact unit with built-in controls. It consists of 2 to 4 non-self-priming multistage vertical high-pressure centrifugal pumps which are supplied completely piped to each other and mounted on a common base frame.

- The connections for the inlet and discharge line and the electrical mains connection must be installed.
- Any supplied accessories ordered separately must be installed.
- The pressure-boosting system with non-self-priming pumps can be connected both indirectly (Fig. 8 – system separation by a non-pressurised water break tank) and directly (Fig. 7 – connection without system separation) to the water supply mains.
- Detailed instructions for the pump type used can be found in the attached installation and operating instructions for the pump.

Observe the relevant, applicable regulations and standards when using the system for drinking water supply and/or fire extinguishing supply.

The system must be operated and maintained in accordance with the relevant instructions (in Germany according to DIN 1988 (DVGW)) so that the operational reliability of the water supply is permanently guaranteed and neither the public water supply nor other consumption installations are detrimentally affected. The respective applicable regulations or standards (see Intended use page ► 29)) on the connection and type of connection to public water supply networks are to be observed. They may be supplemented by regulations of the water supply companies (WVU) or the responsible fire protection authority. In addition, the local conditions (e.g. a supply pressure that is too high or fluctuating considerably and which might require the installation of a pressure reducer) must also be observed.

Standard and special versions

SiBoost Smart series Wilo pressure-boosting systems are fitted as standard with non-self-priming high-pressure multistage centrifugal pumps with or without built-in frequency converters. The pumps are supplied with water via the inlet collecting pipe.

Where self-priming pumps are used for special versions, or generally in the case of suction from lower-lying tanks, a separate vacuum-proof and pressure-resistant suction line with a foot valve must be installed for each pump. The line must rise continuously from the tank to the system. The nominal diameter of the suction lines must not be smaller than the suction connection of the pumps. Pressure loss caused by restrictions and bends is to be avoided. Counter slopes in the suction line are impermissible as there may be air pockets that result in the suction process being aborted. The installation of a compensation line between the discharge line and the suction line ensures safe closing of the foot valve once the pumps have been deactivated.

The pumps increase the pressure and pump the water to the consumer via the pressure collecting pipe. To do this, they are switched on and off or controlled depending on the pressure. The pressure sensor continuously measures the actual pressure value, converts it into

a current signal and transmits it to the control device. Depending on the requirement and the control mode, the control device switches the pumps on, switches them in, or switches them off. If pumps with built-in frequency converters are used, the speed of one or more of the pumps is changed until the control parameter settings are achieved. (The control modes and control processes are described in greater detail in the control device's installation and operating instructions). The total delivery volume of the system is distributed over several pumps. This has the significant advantage that the system output is adapted very precisely to the actual demand and the pumps are operated in the most favourable performance range in each case. This design delivers a high level of efficiency and an economical energy consumption for the system. The first pump that starts up is called the base-load pump. The remaining pumps needed to reach the system operating point are called peak-load pump(s). If the system is configured to supply drinking water according to DIN 1988, one pump must be designated as a standby pump, i.e. at maximum extraction, one pump is always decommissioned or on stand-by. To ensure that all the pumps are used equally, the control unit cycles the pumps continuously, i.e. the order of switching on and the allocation of the base load/peak load or standby pump functions change regularly.

Diaphragm pressure vessel

The assembled diaphragm pressure vessel (Fig.3, 5 - Item 9) has a total capacity of approx. 8 l.

Function:

- Exerts buffering effect on the discharge side pressure transmitter.
- Prevents oscillation of the control unit when switching the system on and off.
- Guarantees low water extraction (e.g. for smallest leakages) from the storage volume at hand without switching on the base-load pump. This reduces the switching frequency of the pumps and stabilises the operating status of the pressure-boosting system.

Protection against low water level (WMS) in systems without a frequency converter on each pump (HELIX V) (Fig. 1a)

Various kits with integrated pressure switch (Item 22) are provided as optional accessories for direct connection of the system to the public water mains (operation with supply pressure) as protection against low water level (WMS) (Item 14) (Fig. 6a and 6c). This pressure switch monitors the existing supply pressure, and if the pressure is low, it sends a switching signal to the control device.

This kit comes fully assembled and wired when ordering the system with optionally integrated WMS. For retrofitting the WMS, order and install the respective kit (Fig. 6a and 6c). For all systems, an installation point for the WMS is provided as standard at the inlet pipe.

In the case of an indirect connection (system separation by non-pressurised break tank), a level-dependent signal transmitter must be provided and installed in the break tank as a dry-running protection device. If a Wilo break tank is installed (example in Fig. 13a) a float switch is already included in the scope of delivery (see Fig. 13b - Item 50).



NOTICE

For detailed information on the break tank, see installation and operating instructions included.

For existing on-site tanks, you will find various signal transmitters in the Wilo range that can be retrofitted (e.g. float switch WA65 or low water warning electrodes with level relay).

Integrated protection against low water level for systems with frequency converter

On systems with frequency converters on each pump (HELIX VE, HELIX EXCEL, MWISE), the supply pressure is monitored by the pressure sensor on the inlet side and transmitted to the control device as a current signal. If the supply pressure is too low, the system detects a fault and the pumps are stopped. (For a detailed description, see the installation and operating instructions for the control device).

4.6.2 Noise characteristics

**WARNING****Risk of injury from a lack of protective equipment!**

In case of sound-pressure levels above 80 dB(A), there is a risk of hearing impairments.

- Wear suitable hearing protection during operation.

Pressure-boosting systems are supplied with different pump types and a variable number of pumps. The overall noise level for all variants of pressure-boosting systems is not specified here.

HELIX V, up to 37 kW, without frequency converter, 50 Hz

	Number of pumps	Rated power (kW)					
		0.37	0.55	0.75	1.1	1.5	2.2
Max. sound-pressure level (*) LpA in [dB(A)]	1	56	57	58	59	60	63
	2	59	60	61	62	63	66
	3	61	62	63	64	65	66
	4	62	63	64	65	66	69

(*) Values for 50 Hz (constant speed) with a tolerance of +3 dB(A)

LpA = workplace-related emission level in dB(A);

	Number of pumps	Rated power (kW)					
		3	4	5.5	7.5	9	11
Max. sound-pressure level (*) LpA in [dB(A)]	1	66	68	70	70	70	71
	2	70	71	73	73	73	74
	3	72	73	75	75	75	76
	4	73	74	76	76	76	77

(*) Values for 50 Hz (constant speed) with a tolerance of +3 dB(A)

LpA = workplace-related emission level in dB(A);

	Number of pumps	Rated power (kW)				
		15	18.5	22	30	37
Max. sound-pressure level (*) LpA in [dB(A)]	1	71	72	74	75	80 ¹
	2	74	75	77	78	83 ³
	3	76	77	79	80 ¹	85 ⁴
	4	77	78	80 ¹	81 ²	86 ⁵

(*) Values for 50 Hz (constant speed) with a tolerance of +3 dB(A)

LpA = workplace-related emission level in dB(A);

LWA = Sound-pressure level in dB(A) indicated from LpA = 80 dB(A)

1 = LWA=91 dB(A)

2 = LWA=92 dB(A)

3 = LWA=94 dB(A)

4 = LWA=96 dB(A)

5 = LWA=97 dB(A)

HELIX VE, up to 22 kW, with frequency converter

	Number of pumps	Rated power (kW)						
		0.55	0.75	1.1	1.5	2.2	3	4

	Number of pumps	Rated power (kW)						
Max. sound-pressure level (*) LpA in [dB(A)]	1	66	68	70	70	70	71	71
	2	69	71	73	73	73	74	74
	3	71	73	75	75	75	76	76
	4	72	74	76	76	76	77	77

(*) Values for 50 Hz (constant speed) with a tolerance of +3 dB(A)

LpA = workplace-related emission level in dB(A);

	Number of pumps	Rated power (kW)						
		5.5	7.5	11	15	18.5	22	
Max. sound-pressure level (*) LpA in [dB(A)]	1	72	72	78	78	81 ¹	81 ¹	
	2	75	75	81 ¹	81 ¹	84 ³	84 ³	
	3	77	77	83 ²	83 ²	86 ⁴	86 ⁴	
	4	78	78	84 ³	84 ³	87 ⁵	87 ⁵	

(*) Values for 50 Hz (constant speed) with a tolerance of +3 dB(A)

LpA = workplace-related emission level in dB(A);

LWA = Sound-pressure level in dB(A) indicated from LpA = 80 dB(A)

1 = LWA=92 dB(A)

2 = LWA=94 dB(A)

3 = LWA=95 dB(A)

4 = LWA=97 dB(A)

5 = LWA=98 dB(A)

HELIX EXCEL, up to 7.5 kW, with frequency converter

	Number of pumps	Rated power (kW)						
		1.1	22	3.2	4.2	5.5	6.5	7.5
Max. sound-pressure level (*) LpA in [dB(A)]	1	70	70	71	71	72	72	72
	2	73	73	74	74	75	75	75
	3	75	75	76	76	77	77	77
	4	76	76	77	77	78	78	78

(*) Values for 50 Hz (constant speed) with a tolerance of +3 dB(A)

LpA = workplace-related emission level in dB(A);

MVISE

	Number of pumps	Rated power (kW)						
		206	210	404	406	410	803	806
Max. sound-pressure level (*) LpA in [dB(A)]	1	48	50	50	50	53	53	55
	2	51	53	53	53	56	56	58
	3	53	55	55	55	58	58	60
	4	54	56	56	56	59	59	61

(*) Values for 50 Hz (constant speed) with a tolerance of +3 dB(A)

LpA = workplace-related emission level in dB(A);

- The actual rated power of the delivered pumps can be found on the rating plate.

For motor powers not listed here and/or other pump series, see the single pump noise value from the installation and operating instructions for the pumps or from the catalogue information on the pumps. With the following procedure, it is also possible to approximate the overall noise level of the complete system using the noise value for an individual pump of the type supplied:

Calculation		
Single pump	...	dB(A)
2 pumps, total	+3	dB(A) (tolerance +0.5)
3 pumps, total	+4.5	dB(A) (tolerance +1)
4 pumps, total	+6	dB(A) (tolerance +1.5)
Overall noise level =	...	dB(A)

Example (pressure-boosting system with 3 pumps)		
Single pump	74	dB(A)
4 pumps, total	+6	dB(A) (tolerance +3)
Overall noise level =	80...83	dB(A)

4.6.3 Electromagnetic compatibility (EMC)

The individual components (pumps with frequency converter and control device) of this system meet the requirements of the EMC directives and relevant standards.



NOTICE

Observe the respective installation and operating instructions for the individual component.

- Note the following for the overall system:



NOTICE

This professionally used device does not comply with the limit values for harmonic currents of EN 61000-3-12 and IEC 61000-3-12.

For this reason, the responsible energy supply company must be asked to approve the connection.

For further information and installation notes, see Annex 8.3 of EN IEC 61800-3.



NOTICE

In the case of 3~ input power supply, EMC irregularities can occur under unfavourable circumstances when used in residential environments (C1) with low electrical power in the conducted range.

- Contact Wilo customer service.
- More information and instructions can be found in the attached documents.

5 Transport and storage



WARNING

Risk of injury from a lack of protective equipment!

Danger of (serious) injuries during work.

- Wear protective gloves to protect against cuts.
- Wear safety shoes.
- If lifting accessories are used, wear a safety helmet.



WARNING

Risk of injury from falling parts!

Never allow anyone to stand under suspended loads!

- Do not move the load over workplaces where persons are present.

CAUTION

Risk of damage to property!

Unsuitable lifting gear can cause the system to slip out or fall down.

- Only use suitable and approved lifting gear.
 - Never attach the lifting gear to the piping. Use the existing stop lugs (Fig. 12 – Item 13) or the base frame for fixation.
 - Ensure the stability of the load since, with the vertical pump design, the centre of gravity is shifted to the top range (top-heavy, Fig. 12 – Item 60).
-

CAUTION

Risk of damage to property due to incorrect loading!

Subjecting the pipes and valves to loads while in transit can result in leakages.

CAUTION

Risk of damage to property due to environmental influences!

The system can be damaged by environmental influences.

- Take suitable measures to protect the system from moisture, frost and heat as well as mechanical damage.
-



NOTICE

- After removing the packaging, store or assemble the system in accordance with the installation conditions described (see Installation and electrical connection page [▶ 41]).
-

5.1 Delivery

The pressure-boosting system is fixed onto a pallet (Fig. 12 – Item 36), delivered on transport boards or in a transport box. The pressure-boosting system is foil-wrapped (Fig. 12 – Item 59) to protect it against moisture and dust.

- Transport and storage instructions attached to the packaging must be observed.
- The transport dimensions, weights, necessary passageways and transport areas of the system can be found on the supplied installation plan or documentation.
- On delivery and before removing the packaging, check the packaging for damage.

If damage is detected due to a fall or similar:

- Check the pressure-boosting system and accessories for possible damage.
- Notify the delivery company (forwarding agent) or customer service, even if you do not find any obvious damage to the system or its accessories.

5.2 Transport

The system is packed in plastic wrap to protect it against moisture and dirt (Fig. 12 – Item 59).

- If the outer packaging is damaged or no longer present, apply suitable protection from humidity and dirt.
- Do not remove the outer packaging until you are at the installation site.
- If the system is transported again at a later date, fit new suitable protection against moisture and contamination.
- Demarcate and cordon off the working area.
- Keep unauthorised persons away from the working area.
- Use approved lifting slings: Sling chains or polyester webbing slings.
- Attach lifting slings to base frame:
 - Transport with forklift
 - Transport with lifting gear.
 - Fixation lugs on base frame: Sling chain with sling hook with safety latch.

- Screw in the loosely supplied ring eyelets: Sling chain or polyester webbing sling with shackle.
- Permissible angle specifications for the lifting sling (Fig. 1a to 1e, Fig. 12 – Item 13, Item 54)
 - Fixation with sling hook: $\pm 24^\circ$
 - Fixation with shackle: $\pm 8^\circ$
 - If the angle specifications cannot be complied with, use a spreader beam.

5.3 Storage

- Place the system on a firm and even surface.
- Ambient conditions: 10 °C to 40 °C, max. humidity: 50 %.
- Dry hydraulics and pipework before packing.
- Protect the system from humidity and dirt.
- Protect the system from direct exposure to sunlight.

6 Installation and electrical connection



WARNING

Risk of damage to your health!

Risk of damage to your health due to contaminated drinking water.

- No materials that have adverse effects on the quality of the water may be used for drinking water installations.
- Flushing the pipes and system reduces any impairment of the drinking water quality.
- If the system is not used for a longer period of time, replace the water.

6.1 Installation location

Requirements for the installation location:

- Dry, well ventilated and frost-resistant.
- Separate and lockable (e.g. requirement of DIN 1988 standard).
- Free of harmful gases and secured against gas ingress.
- Maximum ambient temperature of +0 °C to 40 °C at a relative humidity of 50 %.
- Availability of adequately sized soil drainage (e.g. sewer connection).
- Horizontal and level installation surface. Slight height adjustment for stabilisation possible with the vibration absorbers in the base frame:
 1. Loosen the counter nut.
 2. Turn the appropriate vibration absorber out or in.
 3. Fix the counter nut again.

Also note:

- Ensure adequate space for maintenance work. The main dimensions can be found in the supplied installation plan. The system should be freely accessible from at least two sides.
- To open the flap of the control device (left side) and for maintenance work in the control device, make sure there is minimum clearance (at least 1000 mm – see Fig. 14).
- Wilo advises against installation and operation near living rooms and bedrooms.
- To avoid the transmission of structure-borne noise and to ensure a stress-free connection to upstream and downstream pipes, compensators (Fig. 9 – Item B) with extension limiters or flexible connection pipes (Fig. 10 – Item B) must be used.

6.2 Installation



DANGER

Risk of fatal injury due to electrical current!

Improper conduct when carrying out electrical work can lead to death due to electric shock!

- Electrical work must be carried out by a qualified electrician in accordance with the locally applicable regulations.
- If the product is disconnected from the mains, secure it against being switched on again.

6.2.1 Foundation/bearing surface

The pressure-boosting system is designed for installation on a level concrete floor. The base frame is mounted on height-adjustable vibration absorbers as means of insulation against structure-borne noise.



NOTICE

For transport reasons, the vibration absorbers may not be installed upon delivery. Before installing the pressure-boosting system, check that all the vibration absorbers are fitted and locked by the threaded nut (Fig. 9 - Item A).

If the customer also wants to fasten the installation to the floor (Fig. 9, 10 - Item E), suitable measures must be taken to avoid structure-borne noise transmission.

6.2.2 Hydraulic connection and pipes

For connections to the public drinking water supply network, the requirements of the responsible local water supply company must be met.

Prerequisites:

- Completion of all welding and soldering work
- Carrying out required rinsing
- If necessary, disinfect the pipeline system and the delivered pressure-boosting system (hygiene according to local regulations (in Germany, according to TrinkwV 2001))

Installation notes:

- On-site piping installation must be completed voltage-free.
- To avoid distortion of the pipe adaptors, use compensators with length limitation or flexible connection pipes. This minimises the transmission of system oscillations to the building installation.
- In order to prevent the transmission of structure-borne noise to the building, do not fix the pipe clamps to the pressure-boosting system pipework (Fig. 9, 10 - Item C).
- The hydraulic connection is made either on the right or left side of the system, depending on the site conditions.
- Disassemble any pre-assembled blind flanges or threaded caps, if required, and assemble them again on the opposite side.

Flow resistance

The flow resistance of the inlet and suction pipes must be kept as low as possible:

- Short piping
- Horizontal piping if possible
- Pressure and vacuum-proof pipes
- Suitable nominal diameter (at least same size as system connection)
- Few elbows
- Sufficiently large shut-off valves
- Avoid automatic extractors

Otherwise, the protection against low water level may be activated due to severe pressure losses in the event of high volume flows:

- Observe the NPSH of the pump
- Avoid pressure losses
- Avoid cavitation



NOTICE

Where systems are fitted with unit casings, it is recommended that these are removed before connection and are refitted after all installation and set-up work has been completed (Fig. 11a, 11b).

Hygiene

Installations in the drinking water supply are subject to special hygiene requirements. In principle, all locally applicable regulations and measures for drinking water hygiene must be observed.

This description follows the German Drinking Water Ordinance (TwVO) in its applicable version.

The supplied pressure-boosting system meets the standards of current technology (in particular DIN 1988) and was checked at the factory to make sure it functions correctly. When used in drinking water applications, the complete drinking water installation has to be handed over to the operator in a perfect state of hygiene.

The following applies here:

- DIN 1988, part 400 and the commentaries on the standard.
- TwVO § 5. Paragraph 4 microbiological requirements: Flushing or disinfecting the system.

The limit values to be observed can be taken from TwVO § 5.



NOTICE

The manufacturer recommends flushing the system for cleaning.

Preparing system flushing

1. Install a T-connector on the end discharge side of the pressure-boosting system (if there is a diaphragm pressure vessel on the discharge side, immediately downstream of it) upstream of the next shut-off valve.
2. Provide the branch with a shut-off valve for draining the sink into the wastewater system during flushing.
3. Adjust the branch according to the maximum volume flow of a single pump (Fig. 7, 8 - Item 28).
4. If it is not possible to achieve free drainage, such as when connecting a hose, the requirements of DIN 1988-200 must be observed.

6.2.3 Install accessories

Fitting dry-running protection

In the event of a direct connection to the public water supply network:

For systems with frequency converters on each pump (HELIX VE, HELIX EXCEL, MWISE), a kit with a pressure sensor is already installed on the inlet side. The pressure sensor monitors the supply pressure and transmits it as current signal to the control device. In this case, no additional accessories are necessary!

For systems without frequency converters on each pump (HELIX V), screw the protection against low water level (WMS) kit into the connection port for the inlet collecting pipe and – if retrofitting – seal it. Establish the electrical connection in the control device according to the installation and operating instructions and the control device circuit diagram (Fig. 6a and 6c).

In the event of an indirect connection (for operation with tanks provided by the customer):

- Install the float switch in the tank so that the “low water” switching signal is transmitted if the water level drops to approximately 100 mm above the draw-off connection. (If break tanks from the Wilo range are used, a float switch is installed (Fig. 13a and 13b).
- Alternatively: Install 3 submersible electrodes in the break tank:
 1. Position the first electrode as an earth electrode just above the base of the tank. The electrode must always be below the water surface for the lower switching level (water shortage).
 2. Position the second electrode for the upper switching level (low water eliminated) approx. 100 mm above the draw-off connection.
 3. Attach the third electrode at least 150 mm above the lower electrode.
 4. Establish the electrical connection in the control device.



NOTICE

Observe the respective manufacturer's documentation for the component.

Install diaphragm pressure vessel



NOTICE

Diaphragm pressure vessels require regular testing according to Directive 2014/68/EU (in Germany, also take into account the Ordinance on Industrial Safety and Health §§ 15(5) and 17 as well as Annex 5).

The diaphragm pressure vessel (8 litre) – which is part of the scope of delivery – is delivered unmounted as an accessories kit for transportation and hygienic reasons.

- The diaphragm pressure vessel must be mounted on the throughflow fitting before commissioning (Fig. 2a, 2c, 3).
- Do not twist the throughflow fitting. The drain valve (see also Fig. 3, B) or the flow direction arrows printed on it must be parallel to the collecting pipe.



NOTICE

Observe the respective manufacturer's documentation for the component.

For systems with pumps of the HELIX EXCEL series (with unit casing) a kit with a diaphragm pressure vessel is included in the scope of delivery.

Installing an additional diaphragm pressure vessel

A throughflow diaphragm pressure vessel according to DIN 4807 must be used for drinking water installations.

- Make sure there is enough room for maintenance or replacement work.
- For maintenance work, install connections for a bypass upstream and downstream of the diaphragm pressure vessel to prevent system downtimes.
- Fully remove the bypass (for examples see diagram Fig. 7, 8 – Item 33) when work is completed to avoid stagnation of the water.



NOTICE

Observe the respective manufacturer's documentation for the component.

- The respective system conditions and the system pumping data must be taken into account when selecting the dimensioning of an additional diaphragm pressure vessel. When doing so, ensure there is sufficient flow through the diaphragm pressure vessel. The maximum volume flow of the pressure-boosting system must not exceed the maximum permissible volume flow of the diaphragm pressure vessel connection (the following table or the specifications on the rating plate and the installation and operating instructions for the tank).

Nominal diameter	DN 20	DN 25	DN 32	DN 50	DN 65	DN 80	DN 100
Connection	(Rp3/4")	(Rp1")	(Rp1 1/4")	Flange	Flange	Flange	Flange
Max. volume flow (m ³ /h)	2.5	4.2	7.2	15	27	36	56

Install safety valve

Installing a safety valve on the end pressure side is necessary if the operating pressure of an installed system component exceeds the maximum permissible value. This is the case if the sum of the maximum possible supply pressure and the maximum delivery pressure of the pressure-boosting system exceeds the permissible operating pressure. The safety valve must be designed so that it will drain off the volume flow occurring in the pressure-boosting system when the positive operating pressure is 1.1 times the admissible level.



NOTICE

Refer to the data sheets and characteristic curves of the pressure-boosting system for the design of the data.

- Securely drain off the outflowing water flow.



NOTICE

Observe the respective manufacturer's documentation for the component.

Install the non-pressurised break tank



WARNING

Risk of injury

Walking on or subjecting areas to load that are not intended for this purpose can lead to accidents and damage

- Walking on plastic containers/the cover is prohibited.

CAUTION

Risk of damage to property

Changes to non-pressurised break tanks can lead to impairment of the statics and to inadmissible deformations or damage to the tank.

- Note that non-pressurised break tanks are statically designed for the nominal capacity.

CAUTION

Risk of property damage due to incorrect handling.

PE tanks from the Wilo range are only designed to collect clean water.

- Clean and flush the break tank before filling it.
- Comply with the maximum water temperature of 50 °C.
- Observe the documentation of the tank.



NOTICE

Clean and flush the non-pressurised break tank before filling it.

To connect the pressure-boosting system indirectly to the public drinking water supply network, install the system together with a non-pressurised break tank according to DIN 1988. The rules for the pressure-boosting system apply to the installation of the break tank as well (see installation location page [▶ 41]).

1. The entire base of the tank must be in contact with a solid bearing surface.
2. The maximum volume of the tank concerned must be considered when dimensioning the bearing capacity of the bearing surface.
3. When installing, make sure there is sufficient space for inspection work (at least 600 mm above the tank and 1000 mm on the connection sides).
4. The tank must not slant when full, because an uneven load may cause damage.

The non-pressurised (i.e. under atmospheric pressure), closed PE tank supplied as an accessory must be installed according to the transport and installation instructions supplied with the tank:

1. Connect the tank without mechanical tension before commissioning. The connection must be made with flexible components, like compensators or hoses.
2. The tank overflow must be connected according to the applicable regulations (in Germany, DIN 1988/T3 and 1988-300).
3. Take suitable measures to prevent heat transmission through the connection pipes.
4. The electrical wiring (float switch for protection against low water level) to the control device of the system must be connected before the pressure-boosting system is commissioned.



NOTICE

Observe the respective manufacturer's documentation for the component.

Install the compensators



NOTICE

Compensators are subject to wear. It is necessary to regularly check for cracks or blisters, exposed fabric or other defects (see recommendations in DIN 1988).

For stress-free installation of the pressure-boosting system, connect the pipes using compensators (Fig. 9 - Item B). The compensators must be equipped with a structure-borne noise-insulating extension limiter to absorb the reaction forces that occur.

1. Install the compensators stress-free in the pipes. No alignment errors or pipe displacement must be compensated for with compensators.
2. When installing, the screws must be tightened uniformly, working across diagonals. The ends of the screws must not project beyond the flange.
3. If welding work is done near the compensators, they must be covered for protection (sparks, radiated heat). Do not paint rubber component of compensators and protect against oil.
4. The compensators must be accessible for inspection within the system at all times and must therefore not be covered by the pipe insulation.



NOTICE

Observe the respective manufacturer's documentation for the component.

Install the flexible connection pipes



NOTICE

Flexible connection pipes are subject to wear in operation. Regular checks for leakages or other defects are necessary (see recommendations of DIN 1988).

The flexible connection pipes in the Wilo range consist of a high-quality stainless steel corrugated hose with stainless steel braiding. In the case of pipes with threaded connections, use for stress-free installation of the pressure-boosting system and in the event of slight pipe displacement (Fig. 10 - Item B).

1. Fit the flat-sealing stainless steel screwed connection with female thread to the pressure-boosting system.
2. Install the male pipe thread on the onward pipework.

Observe the following during installation:

- Depending on the respective size, observe the maximum permissible deformations according to the following table (Fig. 10).
- A suitable tool must be used to prevent kinking or twisting during installation.
- In the event of angular displacement of the pipes, fix the system to the floor, taking into account suitable measures for reducing the structure-borne noise.
- Do not include flexible connection pipes in pipe insulation so that they are accessible for inspection at all times.

Nominal diameter Connection	Thread of screwed connection	Tapered male thread	Max. bend radius RB in mm	Max. bend angle BW in °
DN 32	Rp1 1/4"	Rp1 1/4"	250	60
DN 40	Rp1 1/2"	Rp1 1/2"	260	60
DN 50	Rp2"	Rp2"	300	50
DN 65	Rp2 1/2"	Rp2 1/2"	370	40

Install the pressure reducer

The use of a pressure reducer becomes necessary:

- In case of pressure fluctuations in the inlet pipe of more than 1 bar.
- In the event of a pre-pressure fluctuation that is so great that the system must be shut down.
- If the total pressure (supply pressure and pump delivery head at zero flow point) exceeds the rated pressure.



NOTICE

Refer to the data sheets and characteristic curves of the pressure-boosting system for the design of the data.

The pressure reducer requires a minimum pressure drop of approx. 5 m or 0.5 bar. The pressure downstream of the pressure reducer (back-pressure) is the basis for the total delivery head calculation of the pressure-boosting system. When installing a pressure reducer, there must be an installation section of approximately 600 mm on the supply pressure side.



NOTICE

Observe the respective manufacturer's documentation for the component.

6.3 Electrical connection



NOTICE

- For the electrical connection, observe the relevant installation and operating instructions.
- Observe the enclosed electrical circuit diagrams and connection diagrams.

Pressure-boosting systems in the SiBoost Smart series are equipped with control devices in the SC, SC-FC or SCe(2.0) series.

Points to be taken into account:

- Technical electrical current type, voltage and frequency of the power supply network must match the details on the rating plate of the control device.
- Electrical connection cables must be adequately dimensioned for the total power of the pressure-boosting system (see rating plate).
- External fuse protection of the connection cable for the pressure-boosting system must be provided in accordance with the applicable local regulations (e.g. VDE0100, part 430) in compliance with the details in the installation and operating instructions.
- As a protective measure, the pressure-boosting system must be earthed according to regulations (i.e. according to the local regulations and circumstances), and the connections intended for this purpose must be identified.

Additional protection against dangerous contact voltages

- For pressure-boosting systems without a frequency converter (SC), install a residual-current device, type A (RCD) with a trigger current of 30 mA.
- For a pressure-boosting system fitted with frequency converter(s) (SC-FC or SCe), install a residual-current device type B (RCD-B) with a trigger current of 300 mA.
- The protection class of the system and of the individual components can be taken from the rating plates and/or data sheets.



NOTICE

Observe the corresponding installation and operating instructions and the attached electrical wiring diagrams.

**DANGER****Danger of death due to electrical current!**

Improper conduct when carrying out electrical work can lead to death due to electric shock!

- Only have electrical connection established by an electrician approved by the local energy supply company.
- Observe applicable local regulations.
- Before swapping the phases, switch off the main switch of the system and secure it against unauthorised restarting.

**DANGER****Danger of death as supply pressure is too high!**

Excessive supply pressure (nitrogen) in the diaphragm pressure vessel can lead to damage or destruction of the vessel and thus to personal injury.

- Observe the safety measures for handling pressurised vessels and technical gases.
- The pressures in these installation and operating instructions (Fig. 3, 4) are given in **bar**. If other units of pressure measurement are used, convert the figures correctly.

**WARNING****Foot injuries due to a lack of protective equipment!**

Danger of (serious) injuries during work.

- Wear safety shoes.

CAUTION**Risk of damage to property!**

Dry running can lead to the pump developing leakages and to motor overload.

- Ensure that the pump does not run dry to protect the mechanical seal and the plain bearings.

**NOTICE**

We recommend that the initial commissioning of the system is performed by the Wilo customer service department.

- Contact your dealer, your nearest Wilo representative or the Wilo customer service department.

**NOTICE****Automatic activation after power cut**

Depending on the process, the product is activated and deactivated using separate controls. The product may automatically be activated following power cuts.

7.1 Preparations and control measures

- Check that all on-site wiring has been performed correctly, in particular the earthing, prior to initial activation.
- Check that the pipe adaptors are not under stress.
- Fill the system and carry out a visual inspection for leakages.
- Open the shut-off valves at the pumps and in the suction and discharge line.

- Open the pump venting screws and fill the pumps slowly with water to allow the air to escape completely. Close the venting screws once the pumps have been fully vented.
- In suction mode (i.e. negative level difference between break tank and pumps), the pump and the suction line must be filled via the opening in the venting screw (use a funnel).
- When a diaphragm pressure vessel (optional or accessory) is installed, check that it is set to the correct supply pressure (Fig. 3, 4). To do so:
 1. Depressurise the diaphragm pressure vessel on the water side:
 - ⇒ Close the flow-through fixture (Fig. 3 – Item A).
 - ⇒ Allow the residual water to escape via the drain (Fig. 3 – Item B).
 2. Remove the top dust cap.
 3. Check the gas pressure at the air valve of the diaphragm pressure vessel with an air pressure gauge (Fig. 3 – Item C):
 - ⇒ If the pressure is too low (PN 2 = pump switch-on pressure p_{\min} minus 0.2 – 0.5 bar or value given in the table on the tank (Fig. 4)), correct by filling with nitrogen by the Wilo customer service.
 - ⇒ If the pressure is too high: Release nitrogen from the valve until the required value is reached.
 4. Reinstall the dust cap.
 5. Close the drain valve on the flow-through fixture
 6. Open the flow-through fixture.
- For system pressures > PN 16, the manufacturer's filling instructions should be observed for the diaphragm pressure vessel, see installation and operating instructions for the diaphragm pressure vessel.
- In the case of an indirect connection, check that the water level in the break tank is adequate, or with a direct connection, that the inlet pressure is adequate (minimum inlet pressure 1 bar).
- Check correct installation of the right dry-running protection (see protection against low water level page [▶ 49]).
- Position the float switch and electrodes for the protection against low water level in the break tank so that the pressure-boosting system is switched off at the minimum water level (see Protection against low water level page [▶ 49]).
- Rotation control for pumps with a standard motor without integrated frequency converter:
 - Switch on briefly to check whether the direction of rotation of the pumps matches the arrow on the pump housing. Swap phases if the direction of rotation is incorrect.
- Check the motor protection switch in the control device to make sure that the correct rated current is set according to the specifications on the motor rating plate.
- Check and set the operating parameters required on the control device in accordance with the attached installation and operating instructions.



NOTICE

Observe the respective installation and operating instructions for the individual component.

7.2 Protection against low water level (WMS)

7.2.1 For operation with supply pressure

Systems without frequency converter on each pump (HELIX V)

The pressure switch for the optional low-water cut-out switchgear (WMS) kit (Fig. 6a to 6c) for monitoring the supply pressure is permanently set in the factory. It is not possible to change this setting!

- 1 bar: Deactivation in case of undershoot
- Approx. 1.3 bar: Reactivation in case of overshoot

When using another pressure switch as the low-water signal transmitter, observe the accompanying description about its configuration options.

**NOTICE**

Observe the respective manufacturer's documentation for the component.

Systems with frequency converter on each pump (HELIX VE, HELIX EXCEL and MWISE)

The pressure sensors installed on the inlet side can also be activated by the control device as a signal transmitter for protection against low water level (Fig. 6d to 6f) to monitor supply pressure. The pressure value for switching off and switching back on can be set to a specific range in the control device. The system's factory settings are that the system deactivates when pressure falls below 1.0 bar and reactivates when it exceeds 1.3 bar.

- For more detailed descriptions of the activation procedure and settings, see the installation and operating instructions provided for the control device.

If another pressure switch is used as the low-water signal transmitter, observe the accompanying description about the configuration options.

- The necessary control device settings are to be taken from the installation and operating instructions provided for the control device.

**NOTICE**

Observe the respective manufacturer's documentation for the component.

7.2.2 For operation with break tank (inlet mode)

With Wilo break tanks, the level-dependent low-water monitoring is performed via a float switch (see example Fig. 13a and 13b).

- Connect the float switch before commissioning in the control device.
- For systems with frequency converter on each pump (HELIX VE, HELIX EXCEL), the setting for the protection against low water level may need to be deactivated via the pressure sensor on the suction side.

**NOTICE**

Observe the respective installation and operating instructions for the individual component.

7.3 Commissioning the system**WARNING****Risk of damage to your health!**

Risk of damage to your health due to contaminated drinking water.

- Ensure that pipe and system flushing has been carried out.
- If the system is not used for a longer period of time, replace the water.

Once all preparations and control measures have been carried out according to "General preparations and control measures" section:

1. Switch on the main switch.
2. Set the control to automatic mode.
 - ▶ The pressure sensor measures the pressure at hand and transmits a corresponding current signal to the control device. If the pressure is less than the set start-up pressure, depending on the parameter settings and the control mode, the control device first switches on the base-load pump and, if required, the peak-load pump(s) until the consumer pipes are filled with water and the set pressure has built up.

8 Shutdown/dismantling

In case of maintenance or repair, take the pressure-boosting system out of operation as follows:

1. Switch off the voltage supply and secure it against unauthorised reactivation.
2. Close the shut-off valve upstream and downstream of the system.

3. Shut off the diaphragm pressure vessel at the throughflow fitting and drain it.
4. Drain the system completely if necessary.
 - In case of prolonged decommissioning, drain all pumps by opening the drain plugs on the pump support foot.

9 Maintenance

9.1 Checking the pressure-boosting system

To guarantee maximum operational reliability at the lowest possible operating costs, we recommend regular inspection and maintenance of the pressure-boosting system (see DIN 1988). It is advisable to enter into a maintenance contract with a specialist company or with the Wilo customer service department.

The following checks must be carried out on a regular basis:

- Inspection of the pressure-boosting system's readiness for operation.
- Inspection of the mechanical seals on the pumps. The mechanical seals need water for lubrication. Water may leak out of the gasket slightly. In case of a larger water leak, replace the mechanical seal.
- Optional: Check the diaphragm pressure vessel (a 3-month cycle is recommended) for correct supply pressure setting and impermeability (Fig. 3 and 4).

9.2 Checking the supply pressure

CAUTION

Risk of damage to property through incorrect supply pressure!

Incorrect supply pressure influences the functionality of the diaphragm pressure vessel and can lead to increased wear of the diaphragm and to system malfunctions. Excessive supply pressure will damage the diaphragm pressure vessel.

- Check supply pressure.

- Depressurise the tank on the water side (close the flow-through fixture (Fig. 3 - Item A). Allow the residual water to escape via the drain (Fig. 3 - Item B).
- Check the gas pressure at the diaphragm pressure vessel valve (top, remove dust cap) with an air pressure gauge (Fig. 3 - Item C).
- If necessary, correct the pressure by filling the system with nitrogen. (PN 2 = pump cut-in pressure p_{\min} minus 0.2 – 0.5 bar or value given in the table on the tank (Fig. 5) – Wilo customer service). If the pressure is too high, release nitrogen from the valve.

In the case of systems with a frequency converter, the inlet and outlet filters of the fan must be cleaned if they are very dirty.

In case of longer downtime, see Shutdown/dismantling [► 50].

10 Faults, causes and remedies



NOTICE

- Have faults, particularly those affecting the pumps or the control unit, remedied exclusively by the Wilo customer service or a specialist company.



NOTICE

- The general safety instructions must be observed during any maintenance or repair work.
- The installation and operating instructions of the pumps and the control device must be observed.

Fault	Cause	Remedy
Display on the control device or frequency converter incorrect		Observe the installation and operating instructions for the control device and the pump.
Pump(s) do(es) not start	No mains voltage	Check the fuses, cables and connections.

Fault	Cause	Remedy
	Main switch "OFF"	Switch on the main switch.
	Drive adjustment on the control device "off"	Check settings on the control device, set to "Auto" for normal operation.
	Water level in the break tank too low, i.e. low water level reached	Check the inlet valve/supply line of the break tank.
	Low water level triggered	Check the inlet pressure and the level in the break tank.
	Low water cut-out switch or pressure sensor on the inlet side is faulty	Check and replace the low water switch or pressure sensor if necessary.
	Electrodes connected incorrectly or pressure for low water cut-out switch set incorrectly	Check the installation and setting and correct as required.
	Inlet pressure is above start-up pressure	Check the default values, correct if necessary.
	Start-up pressure is set too low	Check the setting, correct if necessary.
	Shut-off device closed at pressure sensor	Check shut-off valve, if necessary, open the shut-off valve
	Fuse defective	Check the fuse protection and replace it if necessary.
	Motor protection has triggered	Check the default values against the pump and motor data, measure the current values and correct the setting if necessary. Check the motor for defects and replace it if necessary.
	Power contactor defective	Check and replace it if necessary.
	Turn-to-turn fault in the motor	Check, if necessary, replace motor or have it repaired.
Pump(s) do not switch off	Major fluctuations of the inlet pressure	Check the inlet pressure and take measures to stabilise the supply pressure if necessary (e.g. pressure reducers).
	Inlet pipe clogged or shut off	Check the inlet pipe and, if necessary, remove the clogging or open the shut-off valve.
	Nominal diameter of the inlet pipe too small	Check the inlet pipe and increase the cross-section of the inlet pipe if necessary.
	Inlet pipe installed incorrectly	Check the inlet pipe and change the pipe routing if necessary.
	Air in the inlet	Check and, if necessary, seal the piping and vent the pumps.
	Impellers clogged	Check the pump and replace it or have it repaired if necessary.
	Non-return valve leaking	Check and replace the seal or non-return valve if necessary.
	Non-return valve clogged	Check and remove the clogging or replace the non-return valve if necessary.
	Gate valve in the system closed or not sufficiently open	Check shut-off valve, open fully if necessary.
	Volume flow too high	Check the pump data and default values, correct if necessary.
	Shut-off valve closed at pressure sensor	Check shut-off valve, open if necessary.
	Switch-off pressure set too high	Check the setting, correct if necessary.
	Incorrect direction of rotation of the motors	Check the direction of rotation and correct it by changing over phases if necessary.
	Drive adjustment on the control device "Manual"	Check settings on the control device, set to "Auto" for normal operation.
Switching frequency too high or fluttering	Major fluctuations of the inlet pressure	Check the inlet pressure and take measures to stabilise the supply pressure if necessary (e.g. pressure reducers).

Fault	Cause	Remedy
	Inlet pipe clogged or shut off	Check the inlet pipe and, if necessary, remove the clogging or open the shut-off valve.
	Nominal diameter of the inlet pipe too small	Check the inlet pipe and increase the cross-section of the inlet pipe if necessary.
	Inlet pipe installed incorrectly	Check the inlet pipe and change the pipe routing if necessary.
	Shut-off device closed at pressure sensor	Check shut-off valve, open if necessary.
	No diaphragm pressure vessel present (optional or accessory)	Retrofit a diaphragm pressure vessel.
	Supply pressure at existing diaphragm pressure vessel incorrect	Check the supply pressure, correct if necessary.
	Shut-off valve on existing diaphragm pressure vessel closed	Check shut-off valve, open if necessary.
	Existing diaphragm pressure vessel defective	Check the diaphragm pressure vessel and replace it if necessary.
	Switching difference set too low	Check the setting, correct if necessary.
Pump(s) does(do) not run smoothly and/or make(s) unusual noises	Major fluctuations of the inlet pressure	Check the inlet pressure and take measures to stabilise the supply pressure if necessary (e.g. pressure reducers).
	Inlet pipe clogged or shut off	Check the inlet pipe and, if necessary, remove the clogging or open the shut-off valve.
	Nominal diameter of the inlet pipe too small	Check the inlet pipe and increase the cross-section of the inlet pipe if necessary.
	Inlet pipe installed incorrectly	Check the inlet pipe and change the pipe routing if necessary.
	Air in the inlet	Check and, if necessary, seal the piping and vent the pumps.
	Air in the pump	Vent the pump, check the impermeability of the suction line and seal it if necessary.
	Impellers clogged	Check the pump and replace it or have it repaired if necessary.
	Volume flow too high	Check the pump data and default values, correct if necessary.
	Incorrect direction of rotation of the motors	Check the direction of rotation and correct it by changing over phases if necessary.
	Mains voltage: A phase is missing	Check the fuses, cables and connections.
	Pump not adequately fixed to base frame	Check the fixation and re-tighten the fastening screws if necessary.
	Bearing damage	Check the pump/motor and replace it or have it repaired if necessary.
Motor or pump getting too hot	Air in the inlet	Check and, if necessary, seal the piping and vent the pumps.
	Shut-off valve in the system closed or not sufficiently open	Check shut-off valve, open fully if necessary.
	Impellers clogged	Check the pump and replace it or have it repaired if necessary.
	Non-return valve clogged	Check and remove the clogging or replace the non-return valve if necessary.
	Shut-off valve closed at pressure sensor	Check and if necessary, open shut-off valve.
	Deactivation point set too high	Check the setting, correct if necessary.
	Bearing damage	Check the pump/motor and replace it or have it repaired if necessary.
	Turn-to-turn fault in the motor	Check, if necessary, replace motor or have it repaired.

Fault	Cause	Remedy
	Mains voltage: A phase is missing	Check the fuses, cables and connections.
Current consumption too high	Non-return valve leaking	Check and replace the seal or non-return valve if necessary.
	Volume flow too high	Check the pump data and default values, correct if necessary.
	Turn-to-turn fault in the motor	Check, if necessary, replace motor or have it repaired.
Motor protection switch triggers	Mains voltage: A phase is missing	Check the fuses, cables and connections.
	Non-return valve defective	Check and replace the non-return valve if necessary.
	Volume flow too high	Check the pump data and default values, correct if necessary.
	Power contactor defective	Check and replace it if necessary.
	Turn-to-turn fault in the motor	Check, if necessary, replace motor or have it repaired.
Pump(s) produce(s) no or too little power	Mains voltage: A phase is missing	Check the fuses, cables and connections.
	Major fluctuations of the inlet pressure	Check the inlet pressure and take measures to stabilise the supply pressure if necessary (e.g. pressure reducers).
	Inlet pipe clogged or shut off	Check the inlet pipe and, if necessary, remove the clogging or open the shut-off valve.
	Nominal diameter of the inlet pipe too small	Check the inlet pipe and increase the cross-section of the inlet pipe if necessary.
	Inlet pipe installed incorrectly	Check the inlet pipe and change the pipe routing if necessary.
	Air in the inlet	Check and, if necessary, seal the piping and vent the pumps.
	Impellers clogged	Check the pump and replace it or have it repaired if necessary.
	Non-return valve leaking	Check and replace the seal or non-return valve if necessary.
	Non-return valve clogged	Check and remove the clogging or replace the non-return valve if necessary.
	Shut-off valve in the system closed or not sufficiently open	Check and if necessary, fully open the shut-off valve.
Dry-running protection switches off although water is present	Low water level triggered	Check the inlet pressure and the level in the break tank.
	Incorrect direction of rotation of the motors	Check the direction of rotation and correct it by changing over phases if necessary.
	Turn-to-turn fault in the motor	Check, if necessary, replace motor or have it repaired.
	Major fluctuations of the inlet pressure	Check the inlet pressure and take measures to stabilise the supply pressure if necessary (e.g. pressure reducers).
	Nominal diameter of the inlet pipe too small	Check the inlet pipe and increase the cross-section of the inlet pipe if necessary.
	Inlet pipe installed incorrectly	Check the inlet pipe and change the pipe routing if necessary.
	Volume flow too high	Check the pump data and default values, correct if necessary.
	Low-water electrodes connected incorrectly or supply pressure switch set incorrectly	Check the installation and setting and correct as required.
	Low water cut-out switch or pressure sensor on the inlet side is faulty	Check and replace the low water switch or pressure sensor if necessary.
	Dry-running protection does not switch off, although water low	Low-water electrodes connected incorrectly or pressure for low water cut-out switch set incorrectly

Fault	Cause	Remedy
	Low water cut-out switch or pressure sensor on the inlet side is faulty	Check and replace the low water switch or pressure sensor if necessary.
Direction of rotation signal lamp on (not for all pump types)	Incorrect direction of rotation of the motors	Check the direction of rotation and correct it by changing over phases if necessary.

You can find information on the pumps or the control device faults not dealt with here in the attached installation and operating instructions for the components concerned.

- If a fault cannot be repaired, contact an installer or Wilo customer service centre.

11 Spare parts

Spare parts are ordered via customer service. To avoid return queries and incorrect orders, the serial or article number must always be supplied. **Subject to change without prior notice!**

12 Disposal

12.1 Oils and lubricants

Operating fluids must be collected in suitable containers and disposed of in accordance with the locally applicable guidelines. Wipe up drips immediately!

12.2 Water-glycol mixture

The operating fluid complies with Water Hazard Class 1 of the German Administrative Regulation of Substances Hazardous to Water (VwVwS). When disposing of it, the locally applicable guidelines (e.g. DIN 52900 on propanediol and propylene glycol) must be observed.

12.3 Protective clothing

Used protective clothing must be disposed off in accordance with the locally applicable guidelines.

12.4 Information on the collection of used electrical and electronic products

Proper disposal and appropriate recycling of this product prevents damage to the environment and danger to your personal health.



NOTICE

Disposal in domestic waste is prohibited!

In the European Union this symbol may be included on the product, the packaging or the accompanying documentation. It means that the electrical and electronic products in question must not be disposed of along with domestic waste.

To ensure proper handling, recycling and disposal of the used products in question, please note the following points:

- Hand over these products at designated, certified collection points only.
- Observe the locally applicable regulations!

Please consult your local municipality, the nearest waste disposal site, or the dealer who sold the product to you for information on proper disposal. See www.wilo-recycling.com for more information about recycling.

12.5 Batteries/rechargeable batteries

Batteries and rechargeable batteries must not be disposed of with domestic waste and they must be removed before product disposal. End consumers are legally obliged to return all used batteries and rechargeable batteries. For this purpose, you can return used batteries and rechargeable batteries free of charge at municipal collection points or specialist retailers.



NOTICE

Disposal in domestic waste is prohibited!

Batteries and rechargeable batteries affected are marked with this symbol. The identifier for the heavy metal they contain is displayed beneath the graphic:

- **Hg** (mercury)
- **Pb** (lead)
- **Cd** (cadmium)

13 Appendix

13.1 Captions

Fig. 1a Example of SiBoost Smart 2HELIX... pressure-boosting system

Fig. 1b Example of SiBoost Smart 3HELIX VE... pressure-boosting system

Fig. 1c Example of SiBoost Smart 4HELIX EXCEL... pressure-boosting system

Fig. 1d Example of SiBoost Smart 3MWISE... pressure-boosting system

Fig. 1e Example of SiBoost Smart 2.0-3HELIX VE... pressure-boosting system

1	Pump(s)
2	Control device
3	Base frame
4	Inlet collecting pipe
5	Pressure collecting pipe
6	Shut-off device on the intake side
7	Shut-off valve on the discharge side
8	Non-return valve
9	Diaphragm pressure vessel
10	Throughflow fitting
11	Pressure gauge
12-1	Pressure sensor (on the discharge side)
12-2	Pressure sensor (on the suction side)
13	Lifting point for attachment of lifting slings
14	Low-water cut-out switchgear (WMS), optional
15	Unit casing (with pump type HELIX EXCEL only)
15a	Inlet-side unit casing cap (with pump type HELIX EXCEL only)
15b	Discharge side unit casing cap (with pump type HELIX EXCEL only)

Fig. 2a Pressure sensor kit, on the discharge side (with MWISE, HELIX V and HELIX VE)

9	Diaphragm pressure vessel
10	Throughflow fitting
11	Pressure gauge
12-1a	Pressure sensor
12-1b	Pressure sensor (plug), electrical connection, PIN assignment
16	Draining/venting
17	Shut-off valve

Fig. 2b Pressure sensor kit, on the discharge side (with HELIX EXCEL)

11	Pressure gauge
12-1a	Pressure sensor
12-1b	Pressure sensor (plug), electrical connection, PIN assignment
16	Draining/venting
17	Shut-off valve

Fig. 2c Pressure sensor kit, on the discharge side (SiBoost2.0 with HELIX VE)

9	Diaphragm pressure vessel
10	Throughflow fitting
11	Pressure gauge
12-1a	Pressure sensor
12-1b	Pressure sensor (plug), electrical connection, PIN assignment
16	Draining/venting
17	Shut-off valve

Fig. 3 Throughflow fitting operation/pressure testing of the diaphragm pressure vessel

9	Diaphragm pressure vessel
10	Throughflow fitting
A	Open/close
B	Drain
C	Check supply pressure

Fig. 4 Reference table nitrogen pressure diaphragm pressure vessel (sticker supplied)

a	Nitrogen pressure according to the table
b	Start-up pressure base-load pump in PE (bar)
c	Nitrogen pressure in PN2 (bar)
d	Notice: Nitrogen measurement without water
e	Notice: Caution! Fill with nitrogen only.

Fig. 5 Diaphragm pressure vessel kit 8 l (for SiBoost Smart HELIX EXCEL only)

9	Diaphragm pressure vessel
10	Throughflow fitting
18	Threaded pipe union (to suit the nominal diameter of the system)
19	O-ring (seal)
20	Counter nut
21	Pipe nipple

Fig. 6a Protection against low water level (WMS) kit for SiBoost Smart HELIX V

11	Pressure gauge
14	Low-water cut-out switchgear (WMS), optional
16	Draining/venting
17	Shut-off valve
22	Pressure switch
23	Plug connector

Fig. 6c Protection against low water level (WMS) kit, PIN assignment and electrical connection

22	Pressure switch (type PS3..)
23	Plug connector
23a	Plug connector type PS3-4xx (2-core) (normally closed contact)
23b	Plug connector type PS3-Nxx (3-core) (changeover contact)
	Core colours:
BN	Brown
BU	Blue
BK	Black

Fig. 6d Kit for pressure sensor on the inlet side (series with HELIX VE and MWISE)**Fig. 6e Kit for pressure sensor on the inlet side (series with HELIX EXCEL)****Fig. 6f Kit for pressure sensor on the inlet side (series SiBoost2.0 with HELIX VE)**

11	Pressure gauge
12-2a	Pressure sensor
12-2b	Pressure sensor (plug), electrical connection, PIN assignment
16	Draining/venting
17	Shut-off valve

Fig. 7 Example of a direct connection (hydraulic diagram)

Fig. 8 Example of an indirect connection (hydraulic diagram)

24	Consumer connections upstream of the pressure-boosting system
25	Diaphragm pressure vessel end pressure side
26	Consumer connections downstream of the pressure-boosting system
27	Infeed connection for system flushing (nominal diameter = pump connection)
28	Draining connection for system flushing (nominal diameter = pump connection)
29	Pressure-boosting system (here with 4 pumps)
30	Diaphragm pressure vessel end inlet side
31	Unpressurised break tank on the inlet side
32	Flushing apparatus for inlet connection of the break tank
33	Bypass for inspection/maintenance (not permanently installed)
34	Building connection to the water supply mains

Fig. 9 Installation example: oscillation absorber and compensator

A	Oscillation absorber (screw it into the threaded inserts provided and secure it with counter nuts)
B	Compensator with extension limiters (accessory)
C	Fixing the pipes downstream of the pressure-boosting system, e.g. with pipe clamps (provided by the customer)
D	Threaded caps (accessory)
E	Floor fixation with structure-borne noise insulation (provided by the customer)

Fig. 10 Installation example: Flexible connection pipes and fixing to the floor

A	Oscillation absorber (screw it into the threaded inserts provided and secure it with counter nuts)
B	Flexible connection pipe (accessory)
BW	Bend angle
RB	Bend radius
C	Fixing the pipes downstream of the pressure-boosting system, e.g. with pipe clamps (provided by the customer)
D	Threaded caps (accessory)
E	Floor fixation with structure-borne noise insulation (provided by the customer)

Fig. 11a Remove unit casing (HELIX EXCEL)

15	Unit casing
35	Quick-release fastening for unit casing
A	Open the quick-release fastenings
B	Swing up the unit casing hoods
C	Remove the casing hoods

Fig. 11b Install unit casing (HELIX EXCEL)

15	Unit casing
35	Quick-release fastening for unit casing
A	Fitting the casing hoods (engage the guide tabs)
B	Swing down the unit casing hoods
C	Close the quick-release fastenings

Fig. 12 Transport instructions

13	Lifting point for attachment of lifting slings
36	Transport pallet (example)
37	Transport equipment (example: pallet truck)

Fig. 12 Transport instructions

38	Transport securing (screws, discs, nuts)
39	Lifting equipment (example: load bar)
40	Protection against overturning (example: attach rope, above centre of gravity)
57	Wooden supports (example)
58	Box with accessories (example)
59	Plastic cover/dust protection
60	Approximate position of the system's centre of gravity (example: 3 pumps)

Fig. 13a Break tank (accessory - example)

41	Inlet (with float valve (accessory))
43	Inspection opening
44	Overflow Ensure adequate drainage. Provide siphon or valve to prevent ingress of insects. No direct connection to the sewer system (free drainage according to EN 1717)
45	Draining
46	Extraction (connection for pressure-boosting system)
47	Terminal box for low-water signal transmitter
49	Level display

Fig. 13b Low-water signal transmitter (float switch) with connection diagram

50	Low-water signal transmitter/float switch
A	Tank full, contact closed (water not low)
B	Tank empty, contact open (low water)
	Core colours
BN	Brown
BU	Blue
BK	Black

Fig. 14 Spatial requirements for access to the control device

2	Control device
---	----------------









wilo



Local contact at
www.wilo.com/contact

Pioneering for You

WILO SE
Wilopark 1
44263 Dortmund
Germany
T +49 (0)231 4102-0
T +49 (0)231 4102-7363
wilo@wilo.com
www.wilo.com