

Wilo-Vardo WEEDLESS-VM.F



en Installation and operating instructions



Vardo WEEDLESS-VM
<https://qr.wilo.com/932>

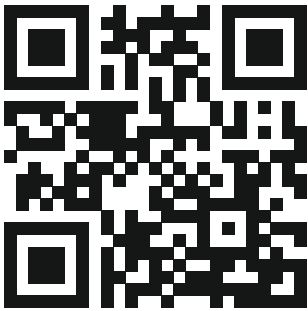

Vardo WEEDLESS-VM (60 Hz)
<https://qr.wilo.com/3932>

Table of contents

| | | | |
|---|-----------|--|-----------|
| 1 General information | 4 | 8.5 Clean and disinfect | 25 |
| 1.1 About these instructions | 4 | 9 Maintenance and repair | 26 |
| 1.2 Copyright | 4 | 9.1 Personnel qualifications | 26 |
| 1.3 Subject to change | 4 | 9.2 Operator responsibilities..... | 26 |
| 1.4 Exclusion from warranty and liability..... | 4 | 9.3 Operating fluid..... | 26 |
| 2 Safety | 4 | 9.4 Maintenance intervals | 26 |
| 2.1 Identification of safety instructions..... | 4 | 9.5 Maintenance measures | 27 |
| 2.2 Personnel qualifications..... | 6 | 9.6 Repairs | 29 |
| 2.3 Personal protective equipment..... | 6 | 10 Faults, causes and remedies | 33 |
| 2.4 Electrical work | 7 | 11 Spare parts | 34 |
| 2.5 Monitoring devices | 7 | 12 Disposal | 34 |
| 2.6 Drive unit: Gear motor in mixer version | 8 | 12.1 Oils and lubricants..... | 34 |
| 2.7 Fluids hazardous to health..... | 8 | 12.2 Protective clothing | 34 |
| 2.8 Transport..... | 8 | 12.3 Information on the collection of used electrical and elec- tronic products | 34 |
| 2.9 Use of lifting equipment..... | 8 | 13 Appendix | 34 |
| 2.10 Installing/dismantling..... | 9 | 13.1 Shrink disc tightening torques | 35 |
| 2.11 During operation | 9 | | |
| 2.12 Maintenance tasks | 10 | | |
| 2.13 Operating fluid | 10 | | |
| 2.14 Operator responsibilities..... | 10 | | |
| 3 Application/use | 10 | | |
| 3.1 Intended use | 11 | | |
| 3.2 Improper use..... | 11 | | |
| 4 Product description | 11 | | |
| 4.1 Design..... | 11 | | |
| 4.2 Operation in an explosive atmosphere | 12 | | |
| 4.3 Type key | 12 | | |
| 4.4 Rating plate..... | 13 | | |
| 4.5 Scope of delivery..... | 13 | | |
| 5 Transportation and storage | 13 | | |
| 5.1 Delivery..... | 13 | | |
| 5.2 Transport..... | 13 | | |
| 5.3 Storage | 15 | | |
| 6 Installation and electrical connection | 15 | | |
| 6.1 Personnel qualifications..... | 15 | | |
| 6.2 Operator responsibilities..... | 15 | | |
| 6.3 Installation | 16 | | |
| 6.4 Electrical connection | 20 | | |
| 6.5 Recommended monitoring devices..... | 21 | | |
| 7 Commissioning | 21 | | |
| 7.1 Personnel qualifications..... | 21 | | |
| 7.2 Operator responsibilities..... | 21 | | |
| 7.3 Direction of rotation..... | 21 | | |
| 7.4 Before activating..... | 22 | | |
| 7.5 Switch on and off..... | 22 | | |
| 7.6 During operation | 22 | | |
| 8 Shut-down/dismantling | 23 | | |
| 8.1 Personnel qualifications..... | 23 | | |
| 8.2 Operator responsibilities..... | 23 | | |
| 8.3 Decommissioning..... | 23 | | |
| 8.4 Dismantling..... | 24 | | |

1 General information

1.1 About these instructions

These instructions form part of the product. Compliance with the instructions is essential for correct handling and use:

- Read the instructions carefully before all activities.
- Keep the instructions in an accessible place at all times.
- Observe all product specifications.
- Observe the markings on the product.

The language of the original operating instructions is German. All other languages of these instructions are translations of the original operating instructions.

1.2 Copyright

WILO SE © 2023

The reproduction, distribution and utilisation of this document in addition to communication of its contents to others without express authorisation is prohibited. Offenders will be held liable for payment of damages. All rights reserved.

1.3 Subject to change

Wilo shall reserve the right to change the listed data without notice and shall not be liable for technical inaccuracies and/or omissions. The illustrations used may differ from the original and are intended as an exemplary representation of the product.

1.4 Exclusion from warranty and liability

Wilo shall specifically not assume any warranty or liability in the following cases:

- Inadequate configuration due to inadequate or incorrect instructions by the operator or the client
- Non-compliance with these instructions
- Improper use
- Incorrect storage or transport
- Incorrect installation or dismantling
- Insufficient maintenance
- Unauthorised repairs
- Inadequate construction site
- Chemical, electrical or electrochemical influences
- Wear

2 Safety

This section contains basic information about the individual stages in the life cycle of the pump. Failure to observe this information leads to:

- Danger to persons
- Danger to the environment
- Property damage
- Loss of claims for damages

2.1 Identification of safety instructions

These installation and operating instructions set out safety instructions for preventing personal injury and damage to property. These safety instructions are shown differently:

- Safety instructions relating to personal injury start with a signal word, are **preceded by a corresponding symbol** and are shaded in grey.



DANGER

Type and source of the danger!

Consequences of the danger and instructions for avoidance.

- Safety instructions relating to property damage start with a signal word and are displayed **without** a symbol.

CAUTION

Type and source of the danger!

Consequences or information.

Signal words

- **DANGER!**
Failure to observe the safety instructions will result in serious injuries or death!
- **WARNING!**
Failure to follow the instructions can lead to (serious) injuries!
- **CAUTION!**
Failure to follow the instructions can lead to property damage and a possible total loss.
- **NOTICE!**
Useful information on handling the product

Markups

- ✓ Prerequisite
- 1. Work step/list
 - ⇒ Notice/instructions
 - ▶ Result

Identifying cross references

The name of the section or table is in inverted commas [“ ”]. The page number follows in square brackets [].

Symbols

These instructions use the following symbols:



Danger caused by electric voltage



Danger – risk of bacterial infection



Danger – explosive atmosphere



General danger symbol



Danger of hand injuries



Danger due to hot surfaces



Danger due to suspended load



Personal protective equipment: wear a safety helmet



Personal protective equipment: wear safety footwear



Personal protective equipment: Wear protective gloves



Personal protective equipment: wear safety harness



Personal protective equipment: wear face mask



Personal protective equipment: wear safety glasses



General warning signs. Observe the notices!



Useful information

2.2 Personnel qualifications

- Personnel have been instructed on locally applicable regulations governing accident prevention.
- Personnel have read and understood the installation and operating instructions.
- Electrical work: qualified electrician
Person with appropriate technical training, knowledge and experience who can identify and prevent electrical hazards.
- Installation/dismantling work: trained sewage technology professional
Fixation and pipework in wet well and dry well installation, lifting equipment, basic knowledge of wastewater facilities
- Maintenance work: trained sewage technology professional
Application/disposal of operating fluids used, basic engineering knowledge (installation/dismantling)
- Lifting work: trained specialist for the operation of lifting devices
Lifting equipment, lifting gear, attachment points

Children and persons with limited abilities

- Persons under the age of 16: Use of this product is prohibited.
- Persons under the age of 18: Supervise them during use of the product (supervisor)!
- Persons with limited physical, sensory or mental capacities: Use of this product is prohibited!

2.3 Personal protective equipment

The protective equipment specified is the minimum requirement. Observe the requirements of the work regulations.

Protective equipment: Transport, installation, removal and maintenance

- Safety shoes: Protection class S1 (uvex 1 sport S1)
- Protective gloves (EN 388): 4X42C (uvex C500 wet)
- Safety helmet (EN 397): Conforms to standards, protection against lateral deformation (uvex pheos)
(If lifting equipment is used)

Protective equipment: Cleaning work

- Protective gloves (EN ISO 374-1): 4X42C + Type A (uvex protector chemical NK2725B)
- Safety goggles (EN 166): (uvex skyguard NT)
 - Labelling frame: W 166 34 F CE
 - Labelling disc: 0-0.0* W1 FKN CE
 - * Protection level according to EN 170 not relevant for this work.
- Breathing protection mask (EN 149): Half mask 3M series 6000 with filter 6055 A2

Article recommendations

The branded products in the parentheses constitute non-binding suggestions. Similar products from other brands can also be used. Adherence to the standards mentioned is required.

WILO SE does not assume any liability for the adherence of the aforementioned products to the corresponding standards.

2.4 Electrical work

- Electrical work must be carried out by a qualified electrician.
- Disconnect device from the mains and secure it against being switched on again without authorisation.
- Observe applicable local regulations when connecting to the mains power supply.
- Comply with the requirements of the local energy supply company.
- Train personnel on how to make electrical connections.
- Train personnel on the options for switching off the device.
- Follow the motor's instructions to connect electricity.
- Earth the device.

2.5 Monitoring devices

The following monitoring devices must be provided by the customer:

Circuit breaker and motor protection switch

- Install circuit breaker and motor protection switch in accordance with the motor manufacturer's instructions.
- Instable mains supply systems: if necessary, install further protective devices on-site (e.g. overvoltage, undervoltage or phase failure relays, etc.).
- Observe local regulations.

Residual-current device (RCD)

- Install a residual-current device (RCD) in accordance with the regulations of the local energy supply company.
- If people can come into contact with the device and conductive fluids, install a residual-current device (RCD).

2.6 Drive unit: Gear motor in mixer version

The drive unit is the mixer version of a gear motor. For all information, consult the manufacturer's instructions. Retain these instructions and store them with the product.

2.7 Fluids hazardous to health

Hazardous germs form in sewage or in stagnant water. There is a danger of bacterial infections!

- Wear protective equipment!
- Clean and disinfect the product thoroughly after removal!
- Inform all persons about the pumped fluid and the danger it poses!

2.8 Transport

- Locally applicable laws and regulations on work safety and accident prevention must be complied with.
- Demarcate and cordon off the working area.
- Keep unauthorised persons away from the working area.
- Remove loose components from the product.
- Always attach the lifting gear to the attachment points.
- Ensure that the lifting gear is securely attached.
- Observe packaging instructions:
 - Impact-resistant
 - Water-resistant
 - Ensure that the product is properly fixed in place.
 - Use transport securing mechanisms.
 - Protect it against dust, oil and moisture.

2.9 Use of lifting equipment

If lifting equipment (lifting device, crane, chain hoist ...) is used, observe the following points:

- Wear a safety helmet according to EN 397!
- Comply with local regulations on the use of lifting equipment.
- The technically correct use of the lifting equipment is the operator's responsibility!
- **Lifting gear**
 - Use legally specified and approved lifting gear.
 - Select lifting gear based on the attachment point.
 - Attach lifting gear to the attachment point according to local regulations.
- **Lifting equipment**
 - Check its functions properly before use!
 - Sufficient bearing capacity.

- Ensure stability during use.
- **Lifting operation**
 - Do not jam the product when lifting and lowering it.
 - Do not exceed the max. permissible bearing capacity!
 - If necessary (e.g. blocked view), assign a second person to coordinate.
 - No one should stand under suspended loads!
 - Do not move loads over workplaces where persons are present!

2.10 Installing/dismantling

- Wear a safety harness.
- Locally applicable laws and regulations on work safety and accident prevention must be complied with.
- Demarcate and cordon off the working area.
- Keep working area free from ice.
- Remove objects lying around from the work area.
- Keep unauthorised persons away from the working area.
- If the weather conditions mean it is no longer possible to work safely, stop work.
- Work must always be carried out by two persons.
- When working at a height of more than 1 m (3 ft) above the ground, use scaffolding with a safety harness.
- Ensure enclosed spaces have sufficient ventilation.
- Toxic or asphyxiating gases may build up in enclosed spaces or buildings. Observe protective measures in accordance with work regulations, e.g. carry a gas detector with you.
- If there is a risk of explosion, do not carry out welding work or work with electrical devices.
- Disconnect device from the mains and secure it against being switched on again without authorisation.
- All rotating parts must stop.
- Disinfect product.

2.11 During operation

- Demarcate and cordon off the working area.
- No persons are allowed in the working area during operation.
- Depending on the process, the product is activated and deactivated using separate controls. The product may automatically be activated following power cuts.
- If the motor emerges, the motor housing can heat up to above 40 °C (104 °F).
- Superior must be informed immediately of any faults or irregularities.
- The product must be switched off immediately if faults occur.
- Propeller must not crash into fixtures or walls. Observe defined clearances in accordance with consulting documents.

2.12 Maintenance tasks

- Observe required water immersion. If water level varies significantly, use level monitoring.
- Sound-pressure level depends on several factors (installation, duty point, etc.). Measure the current noise level under operating conditions. Wear hearing protection at noise levels of 85 dB(A) and over. Demarcate the working area!
- Disconnect device from the mains and secure it against being switched on again without authorisation.
- Only carry out maintenance tasks described in these installation and operating instructions.
- Only original parts of the manufacturer may be used. The use of any non-original parts releases the manufacturer from any liability.
- Collect any leakage of fluid and operating fluid immediately and dispose of it according to the locally applicable guidelines.

Changing gear oil in the drive unit

The oil change procedure uses compressed air. Observe the following points:

- Allow the gear to cool down before opening the gear oil chamber.
- Only insert compressed air in the gear's fill hole.
- To avoid inhaling oil mist, limit the compressed air to 0.8 bar (11.5 psi).

2.13 Operating fluid

The drive unit's gear is filled with gear oil at the factory. Consult the manufacturer's instructions for information on change intervals and disposal of operating fluid.

The interior of the hub is covered with water-resistant grease. Dispose of operating fluid in accordance with local guidelines.

2.14 Operator responsibilities

- Provide installation and operating instructions in a language which the personnel can understand.
- Make sure that the personnel have received the required training for the specified work.
- Provide protective equipment. Ensure that the protective equipment is worn by personnel.
- Ensure that safety and information signs mounted on the device are always legible.
- Train the personnel on how the system operates.
- Fit dangerous components within the system with an on-site guard.
- Demarcate and cordon off the working area.
- Measure the noise level. At noise levels of 85 dB(A) and over, wear hearing protection. Demarcate the working area!

3 Application/use

3.1 Intended use

For suspension and homogenisation in commercial areas of:

- Process sewage
- Sewage containing faeces
- Wastewater (with small amounts of sand and gravel)
- Sludge

Intended use also includes compliance with this manual. Any other use is regarded as non-compliant with the intended use.

3.2 Improper use

The mixers must not be used in:

- Drinking water
- Non-Newtonian fluids
- Severely contaminated fluids containing hard components such as stone, wood, metals, etc.
- Highly flammable and explosive fluids in pure form

4 Product description

4.1 Design

Low-speed vertical mixer with gear motor for stationary installation.

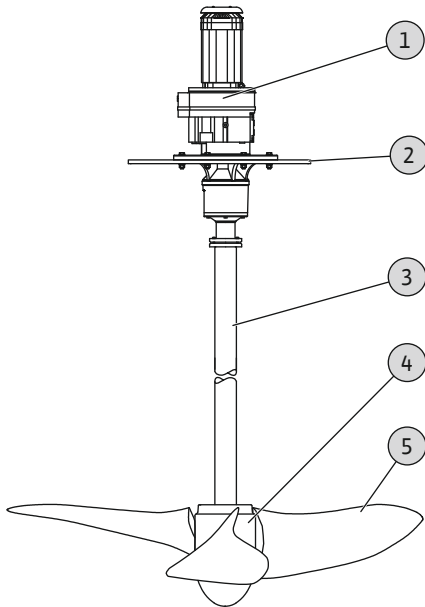

| | |
|---|-----------------|
| 1 | Drive unit |
| 2 | Motor plate |
| 3 | Mixer shaft |
| 4 | Hub |
| 5 | Propeller blade |

Fig. 1: Overview

4.1.1 Drive unit

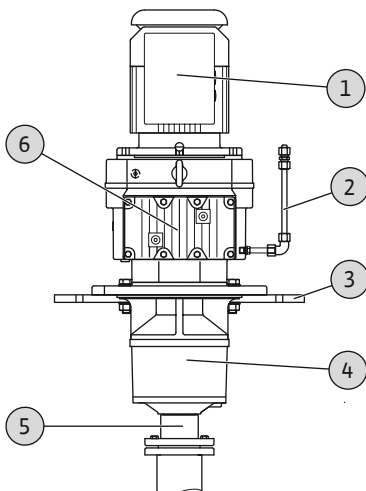

| | |
|---|-----------------|
| 1 | Motor |
| 2 | Oil drain line |
| 3 | Motor plate |
| 4 | Bearing lantern |
| 5 | Output shaft |
| 6 | Gear |

Gear motor

IE3/IE4 gear motor for continuous operation with mixer lantern and additional bearing. The available rated power of the motor is between 0.5 kW and 7.5 kW.

| Mains frequency | Efficiency class IE3 | Efficiency class IE4 |
|-----------------|----------------------|----------------------|
| 50 Hz | • | • |
| 60 Hz | • | – |

Fig. 2: Drive unit components

4.1.2 Hydraulics

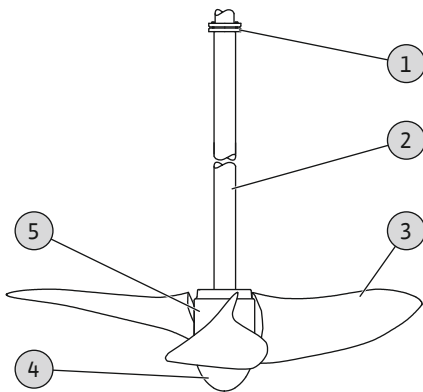

Fig. 3: Hydraulics components

4.1.3 Materials

4.2 Operation in an explosive atmosphere

4.3 Type key

Motor plate

The motor plate connects the drive unit to the structure. For this purpose, the motor plate is available in three versions. If required, the motor plate can be designed according to the system-specific requirements.

| | |
|---|-----------------|
| 1 | Shrink disc |
| 2 | Mixer shaft |
| 3 | Propeller blade |
| 4 | Cover cap |
| 5 | Hub |

Mixer shaft

Mixer shaft made of thick-walled hollow steel. The mixer shaft is connected to the gear motor by a shrink disc. The hub is mounted on the other end of the mixer shaft via two clamping sets.

Propeller

2-blade or 3-blade propeller made of solid material. The nominal diameter of the propeller is 1500, 2000 or 2500 mm. Each propeller blade is attached to the hub. The setting angle of the propeller blade is determined in the process. The direction of thrust can be directed towards the water surface of basin floor. A cover cap is fitted to the hub to protect the hub and propeller fixture from dirt and corrosion.

Drive unit

- Motor housing: EN-AC
- Gear housing: EN-GJL-200 (ASTM A48 Class 30)
- Output shaft: Steel (C45)
- Motor plate: Stainless steel A4 (AISI 316L/316Ti)

Hydraulics

- Mixer shaft: Stainless steel A4 (AISI 316L/316Ti)
- Rotary shaft seals: FKM
- Hub: PUR/A4 (AISI 316L/316Ti)
- Propeller blades: PUR
- Cover cap: PUR

| | Vardo WEEDLESS-VM |
|---------------------|-------------------|
| IECEX certification | – |
| ATEX approval | – |
| FM approval | o |

Key: – = not possible, o = optional

For use in explosive atmospheres, the drive unit be marked as follows on the rating plate:

- “Ex” symbol of the corresponding approval
- Ex classification
- Certification number (depending on the approval)

If required by the approval, the certification number is printed on the rating plate.

Consult the explosion protection chapter in the appendix of these installation and operating instructions for corresponding requirements!

FM approval

The mixers are suitable for operation in potentially explosive atmospheres:

- Protection class: Explosionproof
- Category: Class I, Division 1

Notice: If the cabling is carried out according to Division 1, installation in Class I, Division 2 is also permitted.

Example: **Wilo-Vardo WEEDLESS-VM.F7-1/325.39-400Ex**

Vardo Mixer, vertical with standard motor

WEEDLESS Series with gear motor

| | |
|-------------|-----------------------------------|
| VM.F | Version: securely attached |
| 7 | Size |
| 1 | Model |
| 3 | Number of propeller blades |
| 25 | x100 = nominal propeller diameter |
| 39 | Propeller speed |
| 400 | /100 = rated power in kW |
| Ex | Ex-rated |

4.4 Rating plate



Fig. 4: Rating plate

The following section provides an overview of the abbreviations and associated data on the rating plate:

| | |
|-----------|---|
| Type | Product name |
| S/N | Serial number |
| MFY | Date of manufacture (according to ISO 8601) – JJJJ = year – ww = calendar week |
| P_2 | Required rated power of the mixer |
| n_2 | Propeller speed |
| MS_ϕ | Diameter of mixer shaft |
| MS_L | Length of mixer shaft |
| PBn | Number of propeller blades |
| PBa | Setting angle of propeller blades |
| DoT | Direction of thrust |
| DoR | Direction of rotation |
| M | Mass of the mixer without drive unit CAUTION! For the total mass, the mass of the drive unit must also be added. See rating plate! |
| PU_ϕ | Nominal diameter of the propeller |

NOTICE! For technical data on the drive unit, consult the rating plate!

4.5 Scope of delivery

- Vertical mixer with motor plate, mixer shaft and hub
- Propeller blades packed individually, installation on-site
- Operating and maintenance manual

5 Transportation and storage

5.1 Delivery

- After receiving the shipment, check it immediately for defects (damage, completeness).
- Defects must be noted on the freight documentation.
- Defects must be notified to the transport company or the manufacturer on the day of receipt of shipment.
- Subsequently notified defects can no longer be asserted.

5.2 Transport



WARNING

Suspended loads!

Danger of (serious) injuries caused by falling parts.

- Standing under suspended loads is prohibited!
- Do not move loads over workplaces where persons are present!



NOTICE

Only use properly functioning hoisting and lifting gear!

Only use properly functioning hoisting gear to lift and lower the mixer. Screw the lifting eyes needed for attachment to the motor plate. Ensure that the mixer is not damaged during lifting and lowering. Do **not** exceed the maximum permissible bearing capacity of the lifting equipment. Check that lifting equipment is functioning properly before use!

CAUTION

Material damage due to incorrect transport.

The hub and propeller blades can be damaged when the mixer is lifted.

- When lifting the mixer, place foam padding (min. 20 mm/1 in thick) beneath the hub.
- **Never** set the mixer down on the hub during transport.

- Wear protective equipment! Observe the work regulations.
 - Safety shoes: Protection class S1 (uvex 1 sport S1)
 - Wear safety helmet (EN 397 Conforms to standards, protection against lateral deformation (uvex pheos))! Observe the factory regulations!
- Only remove the outer packaging at the site of use to ensure that the mixer is not damaged during transport.
- Only transport the mixer horizontally when on a pallet and using a forklift truck!
- Only transport the mixer vertically using hoisting gear and lifting slings!
- Use tear-proof plastic sacks of sufficient size to package used mixers for transport in a leak-proof manner.
- Package the drive unit in a water-resistant manner. **Moisture ingress will lead to total failure!** For further information, consult the manufacturer's instructions.

Attachment points

- Comply with applicable national safety regulations.
- Use lifting eyes permitted for angular loading up to 90° (e.g. "Theipa Point TP")
 - Up to 3 kW: M12 lifting eye
 - 4 kW and over: M16 lifting eye
 - Consult type key for motor power!
- **Always screw two lifting eyes** into the motor plate for horizontal transport.
- Use legally specified and approved lifting gear.
- Select the lifting gear based on the prevailing conditions (weather, attachment point, load, etc.).
- Only attach the lifting gear to the attachment point. Fix in place with a shackle.
- Do not stretch lifting gear over the drive unit. If necessary, use a load bar!
- Use lifting equipment with sufficient bearing capacity.
- The stability of the hoisting gear must be ensured during use.
- When using hoisting gear, ensure a second person is present to coordinate the procedure if required (e.g. if the operator's field of vision is blocked).

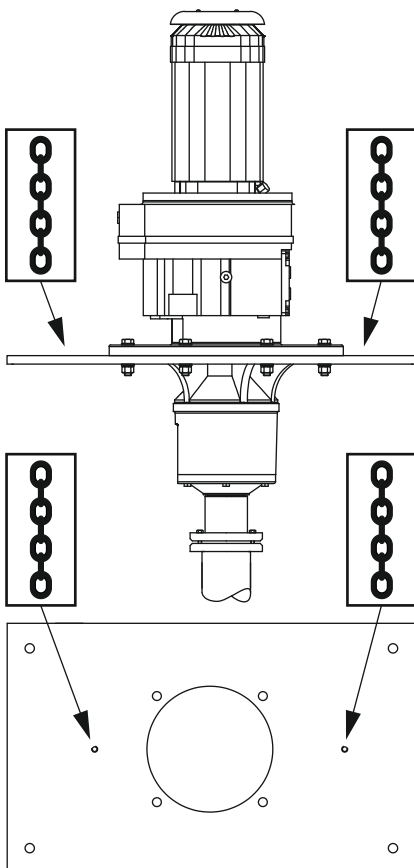

Fig. 5: Motor plate attachment points

5.3 Storage



DANGER

Danger due to fluids which are hazardous to health!

Danger of bacterial infection!

- Disinfect the mixer after removal.
- Observe the specifications of the work regulations.

CAUTION

Total damage due to moisture ingress

The ingress of moisture into the drive unit will result in total damage! Ensure the drive unit is sealed watertight during storage. Prevent condensation from forming! The storage location must be overflow-proof. Observe information in the manufacturer's instructions!

CAUTION

Material damage to the drive unit

If the product is stored in environments with high humidity (e.g. maritime or tropical environments), severe rusting can damage the gear. In such environmental conditions, simply moving the propeller on a regular basis is no longer sufficient. In such cases, add an oil-soluble concentrate with anti-rust additives (concentration approx. 2 %) to the gear oil. For further information, consult the manufacturer's instructions!

Newly supplied mixers can be stored for 2 years. Consult customer service before storing the mixer for more than 2 years.

The following must be observed as regards storage:

- Place the mixer on a solid surface **and secure it against slipping and falling over!**
- The max. storage temperature is -15 °C to $+60\text{ °C}$ (5 °F to 140 °F) at a max. relative humidity of 90 %, non-condensing. Frost-proof storage at a temperature of 5 °C to 25 °C (41 °F to 77 °F) with relative humidity of 40 % to 50 % is recommended.
- Do not store the mixer in rooms in which welding work is carried out. The resulting gases or radiation can corrode the elastomer parts and coatings.
- Protect the mixer from direct sunlight and heat. Extreme heat can cause damage to the propeller and the coating!
- For information on storing the drive unit, consult and observe the manufacturer's instructions!

After storage, remove any dust and oil from the mixer and check the coatings for damage. Repair damaged coatings before further use.

6 Installation and electrical connection

6.1 Personnel qualifications

- Electrical work: qualified electrician
Person with appropriate technical training, knowledge and experience who can identify and prevent electrical hazards.
- Installation/dismantling work: trained sewage technology professional
Fixation and pipework in wet well and dry well installation, lifting equipment, basic knowledge of wastewater facilities

6.2 Operator responsibilities

- Observe locally applicable accident prevention and safety regulations.
- Observe all regulations for working with heavy loads and under suspended loads.
- Provide protective equipment. Ensure that the protective equipment is worn by personnel.
- Demarcate the working area.
- Keep unauthorised persons away from the working area.
- If the weather conditions (e.g. ice formation, strong wind) mean it is no longer possible to work safely, stop work.

- Observe local sewage technology regulations for the operation of sewage systems.
- Structural components and foundations must be of sufficient stability in order to allow the device to be fixed in a secure and functional manner. The operator is responsible for the provision and suitability of the structural component/foundation!
- Check that the available consulting documents (installation plans, installation location, inflow conditions) are complete and accurate.

6.3 Installation



DANGER

Danger due to fluids hazardous to health during installation!

Danger of bacterial infection!

- Clean and disinfect installation location.
- Wipe up drips immediately.
- Observe the specifications of the factory regulations!
- If contact with fluids that are hazardous to health is possible, wear the following protective equipment:
 - sealed safety glasses
 - mouth protection
 - safety gloves



DANGER

Risk of fatal injury due to dangerous lone working practices!

Work in chambers and narrow rooms as well as work involving risk of falling are dangerous work. Such work may not be carried out autonomously!

- Only carry out work with another person!

CAUTION

Material damage due to incorrect fixation

Defective fixation may limit the functionality of the mixer or damage it.

- If the mixer is fixed to a concrete structure, use anchor bolts for fixation. Follow the manufacturer's installation instructions! Temperature specifications and hardening periods must be strictly observed.
- If the mixer is fixed to a steel structure, ensure that the structure is sufficiently strong. Use fixation materials with sufficient strength! Use suitable materials to avoid electrochemical corrosion!
- Tighten all screwed connections. Observe torque specifications.

- Wear protective equipment! Observe the work regulations.
 - Protective gloves: 4X42C (uvex C500 wet)
 - Safety shoes: Protection class S1 (uvex 1 sport S1)
 - Wear a safety harness.
 - Safety helmet: EN 397 Conforms to standards, protection against lateral deformation (uvex pheos)
(When using lifting equipment)
- Prepare the installation site:
 - Clean, free of coarse solids
 - Dry
 - Frost-free
 - Disinfected
- Work must always be carried out by two persons.
- Demarcate the working area.
- Keep unauthorised persons away from the working area.
- From a working height of more than 1 m (3 ft) above the ground, use scaffolding with a safety harness.
- Toxic or asphyxiating gases may build up during work:

- Observe protective measures in accordance with work regulations (gas measurement, carry a gas detector with you).
- Ensure adequate ventilation.
- If toxic or asphyxiating gases accumulate, leave the workplace immediately!
- Install lifting equipment: even surface, clean, firm base. Warehouse and installation location must be easily accessible.
- Attach chain or wire rope to handle/attachment point with a shackle. Only use lifting gear that has been technically approved.
- Do not stay within the swivel range of the hoisting gear.
- All connection cables must be laid properly. The connection cables must not pose any risk (i.e. tripping, damage during operation). Check whether the cable cross-section and the cable length are sufficient for the selected installation type.
- Observe minimum clearances to walls and any fixtures.

6.3.1 Installing the mixer

CAUTION

Material damage due to excessive bending stresses!

If the mixer shaft is not installed perpendicularly, it may be subjected to high bending stresses. These bending stresses can damage the mixer shaft and the gear. To ensure perpendicular installation of the mixer shaft, install the motor plate precisely using equalisation sheets.

Affix the drive unit, with the mixer shaft and hub mounted, to a suitable support structure. Once the mixer has been installed, attach the propeller blades.

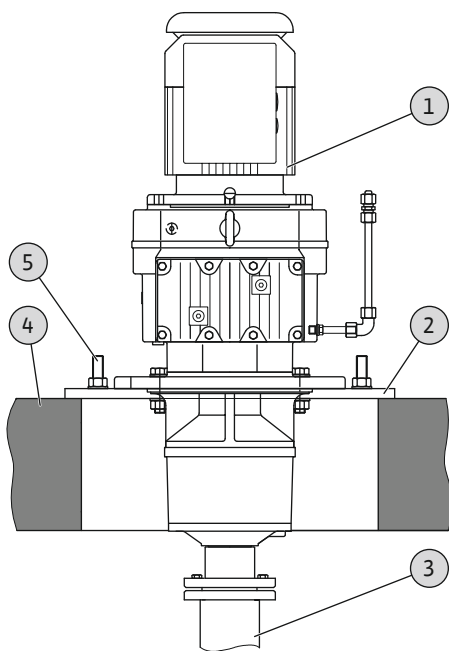

Fig. 6: Installing the mixer

| | |
|---|----------------------|
| 1 | Drive unit |
| 2 | Motor plate |
| 3 | Mixer shaft |
| 4 | Support structure |
| 5 | Motor plate fixation |

- ✓ Slinging point installed on the motor plate.
 - ✓ Work area demarcated and free of any other objects or contaminants.
 - ✓ Ensure work is carried out by two persons.
1. Fasten the hoisting gear to the slinging points.
 2. Slowly lift the mixer. **CAUTION! Material damage! Place a soft surface underneath the mixer while lifting.**
 3. Position the mixer over the support structure.
 4. Slowly lower the mixer. **CAUTION! Material damage! Do not impact the support structure heavily while lowering!**
 - ⇒ Make precise positioning adjustments by hand while lowering.
 5. Lower the mixer until the motor plate rests completely on the support structure.
 - ⇒ Check perpendicular alignment of the mixer shaft. If necessary, adjust the motor plate with equalisation sheets.
 6. Affix the motor plate to the support structure. Tightening torque according to assembly drawing!
 7. Detach hoisting gear.
 - ▶ Mixer is installed. Prepare and attach propeller blades.

6.3.2 Attaching the propeller blades

6.3.2.1 Adjusting the setting angle

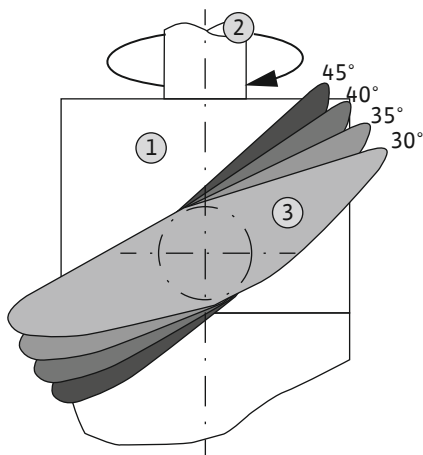

Fig. 7: Propeller blade setting angle

| | |
|---|-----------------|
| 1 | Hub |
| 2 | Mixer shaft |
| 3 | Propeller blade |

In order to achieve the design-relevant specifications in mixing operation, the blades must be attached to the hub with the specified angle of attack. For this purpose, one union insert with an angle of attack of 35/40° is included in the scope of delivery per blade.

The system-specific setting angle is marked on the rating plate.

NOTICE! Other setting angles may only be used following consultation with customer service.



NOTICE

Different setting angles can cause malfunction

Attach all propeller blades with the same setting angle. Different angles may lead to malfunctions.

6.3.2.2 Defining the direction of thrust

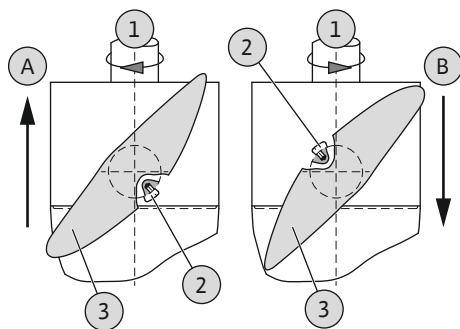

Fig. 8: Propeller blade direction

| | |
|---|-------------------------------|
| A | Direction of thrust: upward |
| B | Direction of thrust: downward |
| 1 | Mixer shaft |
| 2 | Union insert |
| 3 | Propeller blade |

The mixer can exert thrust either upwards or downwards in the operating space. To do this, the direction of rotation and propeller blade direction must match. The illustration shows the blade alignment in relation to the respective thrust direction:

- Clockwise rotation: **Upward** direction of thrust
- Anti-clockwise rotation: **Downward** direction of thrust

Observe the following points:

- *The information on direction of rotation exclusively relates to the mixer when **viewed from above!**
- The propeller blade direction and direction of rotation must match!
- The system-specific specifications regarding **direction of rotation (DoR)** and **direction of thrust (DoT)** are noted on the rating plate!

NOTICE! For the proper direction of rotation, the motor has to be connected in the clockwise or anti-clockwise rotation. The specifications for the electrical connection can be found in the motor instructions!

6.3.2.3 Attaching the propeller blades

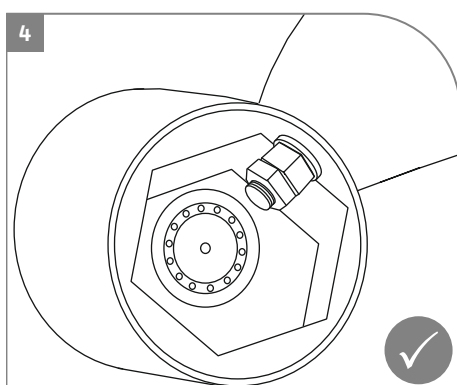
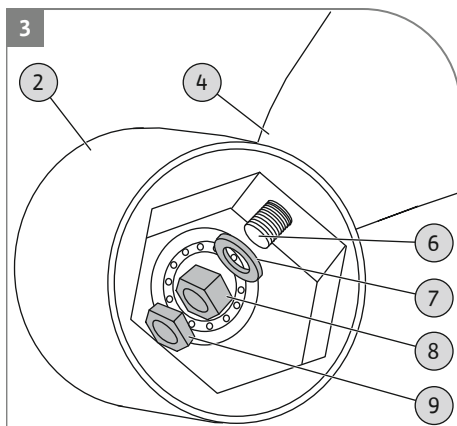
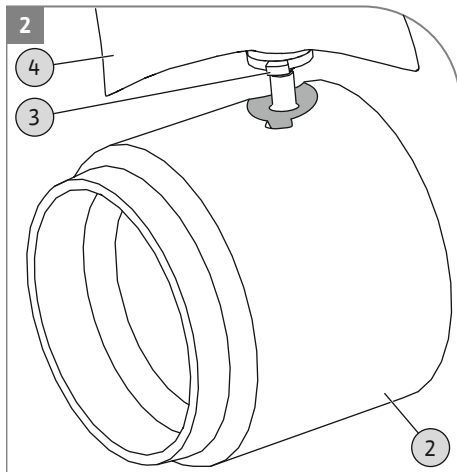
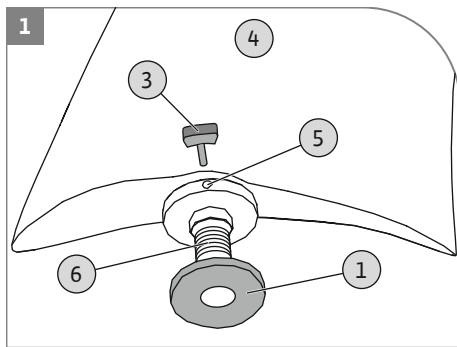

| | | | |
|---|-------------------------------|---|---------------------|
| 1 | Flat gasket | 6 | Threaded pin |
| 2 | Hub | 7 | Washer |
| 3 | Union insert | 8 | Hexagon nut |
| 4 | Propeller blade | 9 | Hexagon counter nut |
| 5 | Drilled hole for union insert | | |

- ✓ The drive unit, with pre-assembled mixer shaft and hub, is firmly affixed to the support structure.
- ✓ Propeller blades and required union inserts are to hand.
- ✓ Setting angle defined.
- ✓ Direction of thrust defined.
- ✓ Torque wrench with width across flats of 55 and 750 Nm (553 ft·lb) is to hand.
- ✓ Ensure work is carried out by two persons.

1. Insert the union insert sideways into the drilled hole.
NOTICE! Observe the angle specification engraved on the union insert. The angle specification must be visible when inserted.
NOTICE! Ensure the propeller blade alignment matches the direction of thrust!
2. Place flat gasket on threaded pin.
3. Insert propeller blade with threaded pin into the specified attachment on the hub, and fix in place. **NOTICE! The union insert must engage in the specified notch on the hub.**
4. Slide the washer onto the threaded pin.
5. Screw the hexagon nut on the threaded pin until hand-tight.
6. Tighten the hexagon nut with the torque wrench. **Tightening torque: 750 Nm (553 ft·lb).**
7. Screw the hexagon counter nut on the threaded pin until hand-tight.
8. Tighten the hexagon counter nut with the torque wrench. **Tightening torque: 750 Nm (553 ft·lb).**
9. Repeat these work steps for each propeller blade.
10. Check that all propeller blades are firmly fixed in place.
 - ▶ Propeller blades are installed. Mount the cover cap.

Fig. 9: Mounting the propeller

6.3.3 Mounting the cover cap

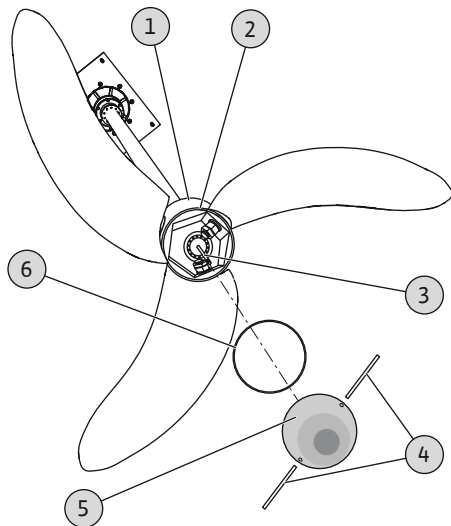

Fig. 10: Installing the cover cap

| | |
|---|---|
| 1 | Hub |
| 2 | Groove for O-ring |
| 3 | Tie rod |
| 4 | Installation aid (steel rod, 2 pcs, 9 x 250 mm) |
| 5 | Cover cap |
| 6 | O-ring |

- ✓ Propeller blades attached.
 - ✓ Installation aid is to hand.
 - ✓ Lubricant is to hand.
1. Cover the interior of the hub with water-resistant grease.
 2. Lightly coat the O-ring with lubricant.
 3. Place the O-ring in the groove.
 4. Screw the **short threaded side** of the tie rod completely into the drilled hole in the mixer shaft until hand-tight.
 5. Screw the cover cap onto the tie rod until hand-tight. **CAUTION! If the O-ring is not completely in the groove, the O-ring will be squeezed and the cover cap will not be sealed!**
 6. Insert the installation aid into the holes on the cover cap and screw tight.
 7. Remove steel rods and retain for future dismantling.
 8. Check that the cover cap is firmly secured.
 - ▶ Cover cap is installed. Make the electrical connection.

6.3.4 Environmental conditions after installation

Flood the basin after installation. **Min. immersion in water: 1 m (3 ft)**. This protects the propeller against environmental influences such as direct sunlight or prolonged periods of frost. If it is not possible to flood the basin, adhere to the storage requirements. See “Storage [▶ 15]”.

CAUTION! Environmental factors such as direct sun exposure or long periods of frost can damage or destroy the elastomer components and coatings. If necessary, pack the propeller in order to provide suitable protection.

6.4 Electrical connection



DANGER

Risk of fatal injury due to electrical current!

Improper conduct when carrying out electrical work can lead to death due to electric shock!

- Electrical work must be carried out by a qualified electrician!
- Observe local regulations!



NOTICE

Observe motor instructions!

For more information, read and comply with the separate motor instructions.

- The mains connection must match the specifications on the motor's rating plate.
- The customer must provide the connection cable and lay it in accordance with local regulations.
- Earth the mixer in accordance with local regulations. The cross-section of the cable must comply with local regulations.

6.4.1 Connecting the drive unit

For information on connecting the drive unit to the mains, consult the manufacturer's documentation!

6.4.2 Intermittent operation

The mixer is suitable for continuous duty. Intermittent operation is also possible. The switch-on procedure must use a soft starter, depending on the switching frequency.

Consult customer service in the case of intermittent operation!

6.5 Recommended monitoring devices

6.5.1 Level monitoring

The propeller must always be immersed during operation. If the fluid level drops below the required immersion level, switch off the mixer! We therefore recommend installing a level monitoring device for applications where the fluid level fluctuates significantly.

7 Commissioning



NOTICE

Automatic activation after power cut

Depending on the process, the product is switched on and off using separate controls. The product may automatically switch on following power cuts.

7.1 Personnel qualifications

- Operation/control: Operating personnel, instructed in the functioning of the complete system

7.2 Operator responsibilities

- Provide installation and operating instructions by the mixer or at a place specially reserved for it.
- Make the installation and operating instructions available in a language the personnel can understand.
- Make sure that the installation and operating instructions are read and understood by all personnel.
- All safety devices and emergency cut-outs on the system-side must be active and checked to ensure that they work properly.
- The mixer is suitable for use under the specified operating conditions.

7.3 Direction of rotation



WARNING

Risk of injury from rotating propeller!

No persons are allowed to be present in the working area of the mixer. There is a risk of injury!

- Demarcate and cordon off the working area.
- If there are no persons in the working area, activate the mixer.
- If persons enter the working area, switch off the mixer immediately.

The drive unit can be operated in clockwise or anti-clockwise rotation. The direction of rotation* of the propeller determines the direction of thrust of the mixer:

- Clockwise rotation: **Upward** direction of thrust
- Anti-clockwise rotation: **Downward** direction of thrust

Observe the following points:

- *The information on direction of rotation exclusively relates to the mixer when **viewed from above!**
- The propeller blade direction and direction of rotation must match!
- The system-specific specifications regarding **direction of rotation (DoR) and direction of thrust (DoT)** are noted on the rating plate!

Checking the direction of rotation

- ✓ Drive unit connected to mains in accordance with the manufacturer's instructions.
- ✓ All connection cables laid properly.
- ✓ No persons in the working area of the mixer.

1. Activate the mixer.
2. Look at the propeller from above and check the direction of rotation. **NOTICE! The required direction of rotation is defined in the system configuration!**
3. If the direction of rotation is incorrect, have the electrical connection changed by a qualified electrician.

4. Check the direction of rotation again.

- ▶ If the direction of rotation is correct, the direction of thrust is as specified in system configuration.

7.4 Before activating

**NOTICE****Observe motor instructions!**

For more information, read and comply with the separate motor instructions.

Check the following prior to activation:

- Check whether the device has been installed properly and in accordance with the locally applicable regulations:
 - Has the mixer been installed correctly and safely?
 - Has the mixer been earthed?
 - Has electrical connection been made in accordance with regulations?
 - Has the connection cable been laid in accordance with regulations?
 - Are mechanical components attached correctly?
 - Have minimum clearances between the propeller and fixtures in the operating space been observed?
- Check the drive unit:
 - Gear: Has preservation oil been removed and the gear filled with operating oil and cleaned?
 - Has specified oil filling (type, quantity, installation position) been ensured?
 - Are oil level and oil drainage screws freely accessible?
 - Has the impermeability of all screwed connections on the gear been checked?
 - Has the user read and implemented the manufacturer's instructions?
- Check the operating conditions:
 - Have the directions of rotation and thrust been tested in accordance with system specification?
 - Intermittent operation – has upstream soft starter been installed?
 - Have the min./max. temperatures of the fluid been tested?
 - Has the max. immersion depth been tested?
 - Has the minimum water coverage of the propeller been defined and is this monitored?

7.5 Switch on and off

The mixer must switch on and off using a separate operating point (on/off switch, switchgear) set by the customer.

- When the mixer starts, the rated current is exceeded for a short time.
- Current consumption continues to be slightly above the rated current during the start-up phase, until the flow in the basin increases.
- During operation, do not exceed the rated current any more.

CAUTION! Material damage! If the mixer does not start up, switch it off immediately. Motor failure! Remove the fault first before reactivation.

7.6 During operation

**WARNING****Risk of burns from hot surfaces!**

The motor can get hot during operation. It may cause burns.

- Allow the motor to cool down to ambient temperature after switching it off.

CAUTION**Incorrect operation can cause material damage!**

The propeller must always be immersed during operation. If the fluid level drops below the required immersion level, switch off the mixer! We therefore recommend installing a level monitoring device for applications where the fluid level fluctuates significantly!



NOTICE

Observe motor instructions!

For more information, read and comply with the separate motor instructions.

During operation, observe the locally applicable regulations on the following topics:

- Workplace safety
- Accident prevention
- Handling electrical machines

Strictly comply with the personnel responsibilities specified by the operator. All personnel are responsible for ensuring compliance with responsibilities and regulations!

Check the following points at regular intervals:

- Operating voltage*
- Frequency*
- Current consumption between individual phases*
- Voltage difference between the individual phases*
- Max. switching frequency*
- Minimal immersion in water of the propeller
- Quiet/low-vibration running

*Tolerance specifications as per manufacturer's instructions!

Increased current consumption

Depending on the fluid and the flow, the current consumption may vary slightly. If current consumption is elevated for a longer period, this indicates a change in conditions and will lead to increased wear of the mixer. The cause for a change in conditions could be:

- Propeller blade setting angle too steep. Check settings and adjust if necessary.
- A change in the viscosity and density of the fluid.
- Insufficient mechanical pre-cleaning, e.g. fibrous and abrasive content.
- Non-homogeneous flow conditions due to fixtures or deflections in the operating space.
- Vibrations due to blockage of the basin inlet/outlet and draining, incorrect air intake (aeration) or the combined effect of several mixers.

Check system configuration and take counter-measures. Contact customer service for further assistance.

8 Shut-down/dismantling

8.1 Personnel qualifications

- Operation/control: Operating personnel, instructed in the functioning of the complete system
- Electrical work: qualified electrician
Person with appropriate technical training, knowledge and experience who can identify and prevent electrical hazards.
- Installation/dismantling work: trained sewage technology professional
Fixation and pipework in wet well and dry well installation, lifting equipment, basic knowledge of wastewater facilities

8.2 Operator responsibilities

- Locally applicable accident prevention and safety regulations of trade associations.
- Observe regulations for working with heavy loads and under suspended loads.
- Provide the necessary protective equipment and make sure that the personnel wears it.
- Provide adequate aeration in closed rooms.
- Take immediate countermeasures if there is a build-up of toxic or suffocating gases!

8.3 Decommissioning



NOTICE

Observe motor instructions!

For more information, read and comply with the separate motor instructions.

The mixer is deactivated during decommissioning, but remains installed. This ensures that the mixer is always ready for operation.

- ✓ To protect the propeller from frost and ice, always immerse the propeller completely in the fluid. **Min. coverage in water: 1 m (3 ft).**
 - ✓ The temperature of the fluid must always be above +3 °C (+37 °F).
1. Switch off the mixer at the operating point.
 2. Secure the operating point against being switched on again by unauthorised persons (e.g. lock main switch).
 - ▶ The mixer is decommissioned and can now be dismantled.

If the mixer remains installed after decommissioning, observe the following:

- Ensure that the requirements for decommissioning are maintained for the complete decommissioning period. If these requirements cannot be guaranteed, package or dismantle the mixer after decommissioning!
- Carry out a 5-minute functional test at regular (monthly to quarterly) intervals.

8.4 Dismantling



DANGER

Danger due to fluids which are hazardous to health!

Danger of bacterial infection!

- Disinfect the mixer after removal.
- Observe the specifications of the work regulations.



DANGER

Risk of fatal injury due to electrical current!

Improper conduct when carrying out electrical work can lead to death due to electric shock!

- Electrical work must be carried out by a qualified electrician!
- Observe local regulations!



WARNING

Risk of burns from hot surfaces!

The motor can get hot during operation. It may cause burns.

- Allow the motor to cool down to ambient temperature after switching it off.



DANGER

Risk of fatal injury due to dangerous lone working practices!

Work in chambers and narrow rooms as well as work involving risk of falling are dangerous work. Such work may not be carried out autonomously!

- Only carry out work with another person!

Wear the following protective equipment while performing the work:

- Safety shoes: Protection class S1 (uvex 1 sport S1)
- Protective gloves: 4X42C (uvex C500 wet)
- Wear a safety harness.
- Safety helmet: EN 397 Conforms to standards, protection against lateral deformation (uvex pheos)
(When using lifting equipment)

If contact with hazardous fluid occurs during work, wear the following additional protective equipment:

- Safety goggles: uvex skyguard NT
 - Labelling frame: W 166 34 F CE

- Labelling disc: 0–0.0* W1 FKN CE
- Breathing protection: Half mask 3M series 6000 with filter 6055 A2

The protective equipment specified is the minimum requirement. Observe the specifications of the work regulations!

* Protection level according to EN 170 not relevant for this work.

Remove by performing the following steps:



NOTICE

Work steps for dismantling

The individual components are dismantled in reverse order to assembly.

- ✓ Mixer decommissioned.
 - ✓ Drive unit has cooled.
 - ✓ Mixer cleaned and, if necessary, disinfected.
 - ✓ Operating space emptied, cleaned and, if necessary, disinfected.
 - ✓ Ensure work is carried out by two persons.
1. Disconnect drive unit from the mains.
 2. Enter the operating space. **DANGER! If the operating space cannot be cleaned and disinfected, wear protective equipment according to work regulations!**
 3. Remove the cover cap.
 - ⇒ See “Mounting the cover cap [▶ 20]”.
 4. Remove the propeller blades.
 - ⇒ See “Attaching the propeller blades [▶ 17]”.
 5. Remove propeller blades, attachments and tools from the operating space.
 6. Leave the operating space.
 7. Release the drive unit from the support.
 - ⇒ See “Installing the mixer [▶ 17]”.
 8. Attach the hoisting gear.
 - ⇒ See “Transport [▶ 13]”.
 9. Slowly lift mixer and remove it from the operating space. **CAUTION! Material damage! While lifting, make sure that the mixer does not collide with the support structure.**
 10. If the fluid has penetrated the hub, clean and disinfect the hub thoroughly and apply a new seal to the interior.
 11. If the mixer is to be stored for an extended period, drain the gear oil and dispose of it in accordance with local regulations! Fill the gear with preservation oil.
 - ⇒ Consult manufacturer’s instructions!
 - ▶ Dismantling is complete. Place the mixer in storage. See “Storage [▶ 15]” and the manufacturer instructions.

8.5 Clean and disinfect

- Wear protective equipment! Observe the work regulations.
 - Safety shoes: Protection class S1 (uvex 1 sport S1)
 - Breathing protection: Half mask 3M series 6000 with filter 6055 A2
 - Protective gloves: 4X42C + Type A (uvex protector chemical NK2725B)
 - Safety goggles: uvex skyguard NT
 - Use of disinfectants:
 - Use strictly according to the manufacturer’s instructions!
 - Wear protective equipment according to the manufacturer’s instructions!
 - Dispose of rinsing water in accordance with the local regulations, e.g. feed it into the sewer!
 - ✓ Mixer removed.
 - ✓ Drive unit packaged in watertight manner.
1. Attach the lifting accessory to the drive unit’s slinging points.
 2. Lift the mixer approximately 30 cm (10 in) above the ground.

3. Spray the mixer with clear water from top to bottom.
4. Spray the propeller blades and cover cap from all sides.
5. Disinfect the mixer.
6. Dispose of dirt residue on the ground, e.g. flush it into the sewer.
7. Leave the mixer and other components to dry.

9 Maintenance and repair



DANGER
Risk of fatal injury due to electrical current!
 Improper conduct when carrying out electrical work can lead to death due to electric shock!

- Electrical work must be carried out by a qualified electrician!
- Observe local regulations!



NOTICE
Observe motor instructions!
 For more information, read and comply with the separate motor instructions.

9.1 Personnel qualifications

- Only perform the maintenance work described in these installation and operating instructions.
- Decommission the mixer before carrying out maintenance tasks; see Decommissioning [▶ 23].
- Electrical work: qualified electrician
 Person with appropriate technical training, knowledge and experience who can identify and prevent electrical hazards.
- Maintenance work: trained sewage technology professional
 Application/disposal of operating fluids used, basic engineering knowledge (installation/dismantling)

9.2 Operator responsibilities

- Provide the necessary protective equipment and make sure that the personnel wears it.
- Collect operating fluids in suitable tanks and dispose of properly.
- Dispose of protective clothing used in accordance with regulations.
- Use only original parts of the manufacturer. The use of any non-original parts releases the manufacturer from any liability.
- Collect any leakage of fluid and operating fluid immediately and dispose of it according to the locally applicable guidelines.
- Provide the tools required.
- If flammable solvents and cleaning agents are used, fire, naked flames and smoking are prohibited.
- Document maintenance tasks in the system's inspection list.

9.3 Operating fluid

9.3.1 Oil types and filling quantities

The gear is filled with gear oil. The type of oil used and the filling quantity is marked on the drive unit's rating plate. For further information on oil types, consult the manufacturer's instructions.

9.3.2 Grease

Use a **water-insoluble** grease for lubrication.

9.4 Maintenance intervals

- Regularly carry out maintenance tasks.
- Contractually adjust maintenance intervals depending on the actual environmental conditions. Contact customer service.
- If strong vibrations occur during operation, check the installation.

9.4.1 Maintenance intervals for normal conditions

| Maintenance measures | Interval | Perform on |
|---|----------|------------|
| Check the insulation resistance of the motor winding. | * | Drive unit |

| Maintenance measures | Interval | Perform on |
|---|----------|---|
| Check the oil level in the gear. | * | Drive unit |
| Check the gaskets. | * | Drive unit |
| Check the impermeability of the terminal box. | * | Drive unit |
| Conduct visual inspection for wear | Annually | Drive unit, mixer shaft, hub, propeller |
| Conduct visual inspection of accessories | Annually | Accessories, attachment parts |
| Conduct visual inspection of mains connection | Annually | Mains connection cable |
| Change oil. | * | Drive unit |

NOTICE! *Consult the motor manufacturer's instructions for intervals and specific measures!

9.4.2 Maintenance intervals for harsh conditions

Under the following operating conditions, shorten the specified maintenance intervals in consultation with the customer service:

- Fluids with long-fibre components
- Highly corrosive or abrasive fluid
- Strongly gassing fluids
- Operation at an unfavourable duty point
- Unfavourable flow conditions (e.g. due to fixtures or aeration)

If there are harsh operating conditions, it is recommended to conclude a maintenance contract.

9.5 Maintenance measures



DANGER

Danger due to fluids hazardous to health when carrying out maintenance tasks!

The mixer is not dismantled to carry out these tasks. Personnel may come into contact with fluids that are hazardous to health. Observe the following points:

- Wear protective equipment:
 - sealed safety glasses
 - mouth protection
 - safety gloves
- Wipe up drips immediately.
- Clean and disinfect tools after use.
- Observe the specifications of the factory regulations!

- Wear protective equipment! Observe the work regulations.
 - Protective gloves: 4X42C (uvex C500 wet)
 - Safety shoes: Protection class S1 (uvex 1 sport S1)
 - Safety goggles: uvex skyguard NT
- Prepare the installation site:
 - Clean, free of coarse solids
 - Dry
 - Frost-free
 - Disinfected
- Demarcate the working area.
- Keep unauthorised persons away from the working area.
- Toxic or asphyxiating gases may build up during work:
 - Observe protective measures in accordance with work regulations (gas measurement, carry a gas detector with you).
 - Ensure adequate ventilation.
 - If toxic or asphyxiating gases accumulate, leave the workplace immediately!

Performing maintenance measures

- ✓ Mixer is decommissioned.

- ✓ Drive unit has cooled to ambient temperature.
 - ✓ Drive unit has been thoroughly cleaned and disinfected (if required).
1. Carry out maintenance measures as prescribed.
 - ⇒ If deficiencies are identified, replace the components. See “Repairs [► 29]”.
 2. Perform maintenance measures in accordance with the manufacturer instructions.
 - Maintenance carried out. Recommission the mixer.

9.5.1 Recommended maintenance measures

Regular inspection of current consumption and the operating voltage in all three phases is recommended for smooth operation. In normal operation, these values remain constant. Slight fluctuations depend on the characteristics of the fluid.

Current consumption can provide an early indication of damage to or malfunctions in the mixer, which can then be rectified. Larger voltage fluctuations strain the motor winding and can cause breakdown. Regular inspections can therefore largely prevent major secondary damage and reduce the risk of total breakdown. In this regard, it is recommended to use remote monitoring for regular inspections.

9.5.2 Visual inspection of the mixer

Check the housing and propeller for damage and wear. If there are defects, observe the following:

- Repair damaged coating. Order repair kits from the customer service.
- If components have worn, contact customer service!

9.5.3 Visual inspection of accessories

Accessories must be checked for:

- Correct fixation
- Smooth function
- Signs of wear, e.g. cracks caused by frequencies

Any defects detected must be repaired immediately or the accessories must be replaced.

9.5.4 Changing gear oil with in-built tool

NOTICE

In-built tool for easy oil changing

Consult the motor's rating plate for information on oil type and quantity. Consult the manufacturer's instructions for safety instructions and detailed work instructions on changing the oil. The following section relates exclusively to the work steps with the in-built tools!

The position in which the drive unit is installed means that the gear's oil drain plug is located directly above the floor fixation. An oil drain line is mounted to the oil drain opening for easy oil change.

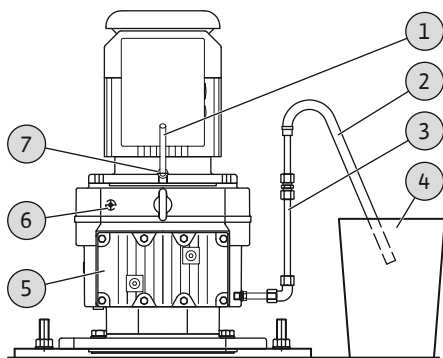

Fig. 11: Oil change

| | |
|---|-------------------------------------|
| 1 | Connection piece for compressed air |
| 2 | Drain hose |
| 3 | Oil drain line with dummy plug |
| 4 | Collector tank |
| 5 | Gear |
| 6 | Oil level screw |
| 7 | Oil filler opening |

- ✓ Mixer has been decommissioned.
- ✓ Drive unit has cooled, been cleaned and, if necessary, disinfected.
- ✓ Work area has been prepared.
- ✓ Protective equipment has been put on.
- ✓ Tools/aids to hand:
 - Drain hose, length approx. 0.5 m (20 in)
 - Compressed air hose, inside diameter 10 mm (0.5 in)
 - Compressed air, max. 0.8 bar (11.5 psi)
 - Collector tank of sufficient volume
 - Funnel
- ✓ Manufacturer's safety instructions have been read and implemented!

1. Remove the screw plug from the oil filler opening.
2. Screw the connection piece into the oil filler opening.
3. Connect the compressed air to the connection piece.
4. Remove the dummy plug from the oil drain line.
5. Attach the drain hose to the oil drain line.
6. Place the drain hose in the collector tank.
7. Slowly release the compressed air. Max. pressure: 0.8 bar (11.5 psi)
8. Drain the gear.
 - ⇒ Ignore any minimal residues.
 - ⇒ If significant residues remain in the gear, rinse the gear repeatedly with cleaning oil.
9. Inspect the oil in the collector tank:
 - ⇒ If the oil is heavily contaminated, rinse the gear repeatedly with cleaning oil.
 - ⇒ If the oil contains metal chips, notify customer service!
10. Remove the drain hose from the oil drain line.
11. Seal the oil drain line with the dummy plug.
12. Detach the compressed air and connection piece from the oil filler opening.
13. Remove the oil level screw to allow venting.
14. Pour new oil into the oil filler opening using a filling funnel. **NOTICE! Consult the motor's rating plate for information on oil type and quantity.**
15. Screw in the oil level screw and the oil filler opening's screw plug.
16. Check all screw plugs for impermeability.
 - ▶ Oil change is complete. Recommission the mixer.

9.6 Repairs



DANGER

Danger due to fluids which are hazardous to health!

Danger of bacterial infection!

- Disinfect the mixer after removal.
- Observe the specifications of the work regulations.



WARNING

Risk of injury from sharp edges!

Sharp edges can form on the propeller blades. There is a danger of cuts and similar injuries!

- Wear protective gloves!

For repair work, the following applies:

- Wear protective equipment! Observe the work regulations.
 - Protective gloves: 4X42C (uvex C500 wet)
 - Safety shoes: Protection class S1 (uvex 1 sport S1)
 - Safety goggles: uvex skyguard NT
- Wipe up drips immediately.
- Always replace O-rings, gaskets and screw locking devices.
- For torques, see "Appendix [▶ 34]".
- Never use inappropriate force when carrying out this work.

Preparatory tasks

- ✓ Work must be carried out by two persons.
- ✓ Mixer decommissioned. See "Decommissioning [▶ 23]".
- ✓ Mixer is removed. See "Dismantling [▶ 24]".
- ✓ Mixer is disinfected. See "Clean and disinfect [▶ 25]".

1. Required tools are to hand.

2. Set the mixer down on a clean, even work surface.
3. Secure the mixer against slipping.
4. Prepare hoisting gear with lifting gear.
5. Prepare scantlings in order to lie the mixer horizontally.
6. Only carry out authorised repairs.
 - ▶ Begin repairs.

9.6.1 Instructions on using screw locking devices

Screwed connections can be fitted with a screw locking device. Self-locking nuts are used as screw locking devices. **Always** replace screw locking devices!

9.6.2 Which repair work may be carried out

- Replacing the cover cap and propeller blades.
- Replacing the hub.
- Replacing the mixer shaft.
- Replacing the drive unit.

9.6.3 Replacing the cover cap and propeller blades



DANGER

Danger due to fluids hazardous to health during installation!

Danger of bacterial infection!

- Clean and disinfect installation location.
- Wipe up drips immediately.
- Observe the specifications of the factory regulations!
- If contact with fluids that are hazardous to health is possible, wear the following protective equipment:
 - sealed safety glasses
 - mouth protection
 - safety gloves



NOTICE

Work steps for dismantling

The individual components are dismantled in reverse order to assembly.

Propeller blade replacement is performed with the mixer installed. Observe the following points:

- Prepare the operating space/installation site:
 - Clean, free of coarse solids
 - Dry
 - Frost-free
 - Decontaminated
- Work must always be carried out by two persons.
- Avoid any painful or tiring body postures.
- When working at a height of more than 1 m (3 ft) above the ground, use scaffolding with a safety harness.
- Cordon off the working area around the scaffolding.
- Toxic or asphyxiating gases may build up when working in closed rooms. Ensure there is sufficient ventilation and observe protective measures according to work regulations (examples):
 - Measure the gas concentration before entering.
 - Carry a gas detector with you.
 - etc.
- Take immediate countermeasures if there is a build-up of toxic or asphyxiating gases.
- To remove/install the cover cap, see “Mounting the cover cap [▶ 20]”.
- To remove/install the propeller blades, see “Attaching the propeller blades [▶ 17]”.
- Inspect the individual propeller blades for wear. Replace all propeller blades if necessary. Consult customer service!
- Note the setting angle. A different angle changes the flow behaviour.

9.6.4 Replacing the hub

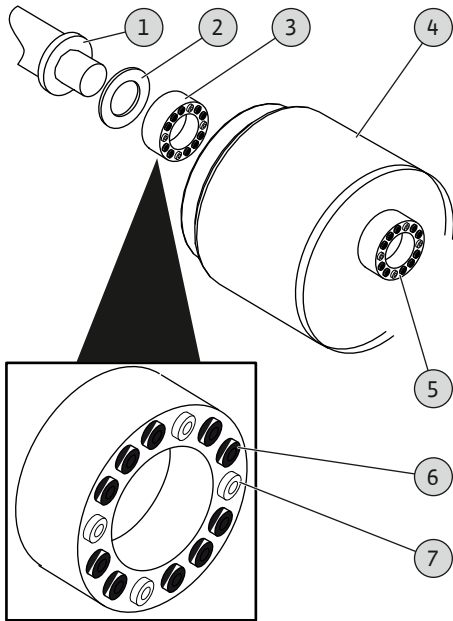

Fig. 12: Installing/dismantling the hub

Disassembling the hub

| | |
|---|---------------------------------------|
| 1 | Mixer shaft |
| 2 | Flat gasket |
| 3 | Tensioning kit, rear |
| 4 | Hub |
| 5 | Tensioning kit, front |
| 6 | Interior hexagonal head screw, black |
| 7 | Interior hexagonal head screw, silver |

- ✓ Propeller blades are removed. See “Attaching the propeller blades [► 17]”.
 - ✓ Cover cap is removed. See “Mounting the cover cap [► 20]”.
 - ✓ Align the mixer shaft horizontally: Position scantlings under the mixer shaft.
1. Loosen the interior hexagonal head screws (black and silver) of the front tensioning kit. **NOTICE! Do not unscrew the screws completely!**
 2. Loosen the tensioning kit: screw out silver screws (M8). Screw in M10 screw and loosen tensioning kit.
 3. Pull the front tensioning kit off the mixer shaft.
 4. Loosen the interior hexagonal head screws (black and silver) of the rear tensioning kit. **NOTICE! Do not unscrew the screws completely!**
 5. Loosen the tensioning kit: screw out silver screws (M8). Screw in M10 screw and loosen tensioning kit.
 6. Pull the hub off the mixer shaft.
 7. Pull the front tensioning kit off the mixer shaft.

Installing the hub

| | |
|----|------------------------------------|
| 1 | Mixer shaft |
| 4 | Interior view of hub |
| 8 | Stretching device (auxiliary tool) |
| 9 | Hexagon head screw |
| 10 | Hub ring |

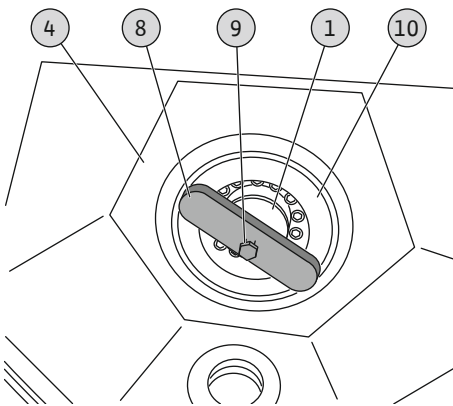

Fig. 13: Mounting the stretching device

- ✓ New flat gasket to hand.
 - ✓ Stretching device to hand.
1. Place the flat gasket on the lower end of the mixer shaft and slide up as far as it will go.
 2. Place the rear tensioning kit on the mixer shaft and slide up as far as it will go.
 3. Place the hub on the mixer shaft and slide up as far as it will go.
 4. Tighten interior hexagonal head screws (4x silver) in a crosswise manner until hand-tight.
 - ⇒ The hub is now secured against slipping.
 5. Tighten interior hexagonal head screws (10x black) in a crosswise manner until hand-tight.
 6. Place stretching device on mixer shaft and hub ring.
 7. Affix the stretching device to the mixer shaft: Screw in the hexagon head screw through the stretching device and into the centring hole in the mixer shaft.
 8. By slowly turning the hexagon head screw, mount the hub completely on the mixer shaft. **NOTICE! End position: The stretching device is flush with the mixer shaft and the hub ring!**
 9. Tighten all interior hexagonal head screws in a crosswise manner. **Tightening torque: 35 Nm (26 ft-lb)!**
 - ⇒ The hub is firmly fixed to the mixer shaft.
 10. Remove the stretching device: Remove the hexagon head screw.
 11. Tighten covered interior hexagonal head screws in a crosswise manner. **Tightening torque: 35 Nm (26 ft-lb)!**

12. Place the front tensioning kit on the mixer shaft and slide up as far as it will go.
13. Tighten front tensioning kit: Tighten all interior hexagonal head screws in a crosswise manner. **Tightening torque: 35 Nm (26 ft·lb)!**
 - ▶ Hub is replaced. Install the mixer, attach the propeller blades and mount the cover cap.

See also

- ▶ Attaching the propeller blades [} 17]
- ▶ Mounting the cover cap [} 20]

9.6.5 Replacing the mixer shaft

To replace the mixer shaft proceed as follows:

1. Dismantle the hub.
2. Dismantle the drive unit.
3. Replace the mixer shaft.
4. Mount the drive unit.
5. Install the hub.
 - ▶ Mixer shaft is replaced. Install the mixer and put into service.

Additional information for the individual work steps:

- See “Replacing the hub [▶ 31]”.
- See “Replacing the drive unit [▶ 32]”.

9.6.6 Replacing the drive unit

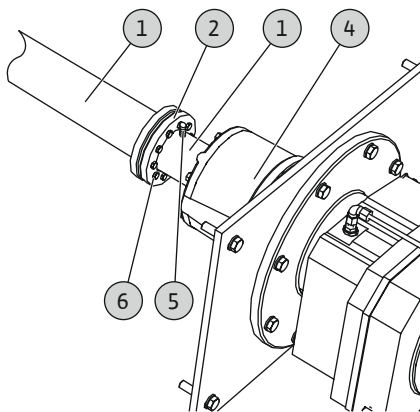

Fig. 14: Removing the mixer shaft

Removing the mixer shaft from the drive unit

| | |
|---|--------------------|
| 1 | Mixer shaft |
| 2 | Shrink disc |
| 3 | Output shaft |
| 4 | Drive unit |
| 5 | Grub screw |
| 6 | Hexagon head screw |

- ✓ Propeller blades are removed. See “Attaching the propeller blades [▶ 17]”.
- ✓ Cover cap is removed. See “Mounting the cover cap [▶ 20]”.
- ✓ Align mixer shaft and drive unit horizontally: Position scantlings under the mixer shaft and drive unit. **WARNING! Risk of crushing! Prop up the mixer and drive unit in such a way that they will not tip over when dismantled!**

1. Unscrew the grub screw.
2. Loosen the hexagon head screws on the shrink disc.
3. Remove the mixer shaft from the output shaft.
4. Remove the shrink disc from the mixer shaft.

Mounting the mixer shaft on the drive unit

1. Place the shrink disc on the upper end (tapered end) of the mixer shaft and slide up as far as it will go.
2. Place the mixer shaft on the output shaft and slide up as far as it will go.
3. Turn the mixer shaft until the grub screw's take-up opening is exactly above the groove on the output shaft.
4. Screw in the grub screw until hand-tight.
5. Tighten the shrink disc's hexagon head screws in a crosswise manner until hand-tight.
6. Tighten hexagon head screws crosswise. For torque, see “Shrink disc tightening torques [▶ 35]”.
7. Ensure that the mixer shaft is securely attached.
 - ▶ Drive unit is replaced. Install the mixer and put it into service.

See also

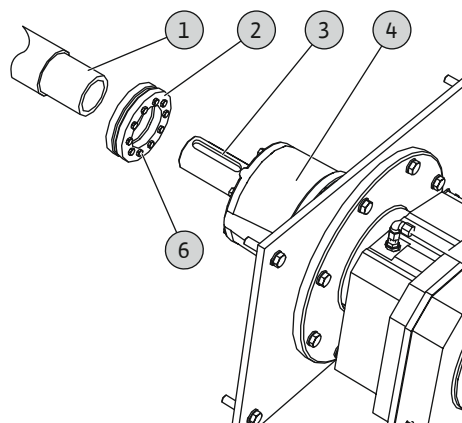

Fig. 15: Mounting the mixer shaft

- ▶ Attaching the propeller blades [} 17]
- ▶ Shrink disc tightening torques [} 35]
- ▶ Mounting the cover cap [} 20]

10 Faults, causes and remedies



DANGER

Danger due to fluids which are hazardous to health!

Wear the following protective equipment while performing the work:

- Closed safety glasses
- Breathing mask
- Safety gloves
 - The equipment listed here is the minimum requirement. Observe factory regulations!



DANGER

Risk of fatal injury due to electrical current!

Improper conduct when carrying out electrical work can lead to death due to electric shock!

- Electrical work must be carried out by a qualified electrician!
- Observe local regulations!



WARNING

Risk of injury from rotating propeller!

No persons are allowed to be present in the working area of the mixer. There is a risk of injury!

- Demarcate and cordon off the working area.
- If there are no persons in the working area, activate the mixer.
- If persons enter the working area, switch off the mixer immediately.



WARNING

Risk of injury from sharp edges!

Sharp edges can form on the propeller blades. There is a danger of cuts and similar injuries!

- Wear protective gloves!



DANGER

Risk of fatal injury due to dangerous lone working practices!

Work in chambers and narrow rooms as well as work involving risk of falling are dangerous work. Such work may not be carried out autonomously!

- Only carry out work with another person!

Fault: The mixer does not start up

1. Interruption to the power supply.
 - ⇒ Is the main switch **ON**?
 - ⇒ Are all phases live?
 - ⇒ Is the connection cable damaged?
2. Fuse is defective.
 - ⇒ Have fuses been checked?
 - ⇒ Are fuses correctly inserted?

3. Motor protection tripped.
 - ⇒ Is excess current release set to rated current?
 - ⇒ Has excess current release been reset?
4. Propeller stiff or blocked.
 - ⇒ Was a test run conducted in an empty basin?
 - ⇒ Clean propeller. **CAUTION! Check the fluid! If the fluid contains coarse solids, check the pre-treatment.**

Fault: Mixer starts up, motor protection trips after short period

1. Propeller stiff or blocked.
 - ⇒ Clean propeller. **CAUTION! Check the fluid! If the fluid contains coarse solids, check the pre-treatment.**
2. Elevated solids content.
 - ⇒ Check the pre-treatment.
 - ⇒ Adjust the setting angle of the propeller blades. Consult customer service.
 - ⇒ Check the operating conditions. Consult customer service.

Further steps for troubleshooting

If the points listed here do not rectify the fault, contact customer service. Customer service can assist in the following ways:

- Telephone or written support.
- On-site support.
- Inspection and repair at the factory.

Costs may be incurred if other services are used from customer service! For more details, please contact customer service.

11 Spare parts

Spare parts are ordered via customer service. To avoid return queries and incorrect orders, the serial or article number must always be supplied. **Subject to change without prior notice!**

12 Disposal

12.1 Oils and lubricants

Operating fluids must be collected in suitable containers and disposed of in accordance with the locally applicable guidelines. Wipe up drips immediately!

12.2 Protective clothing

Used protective clothing must be disposed off in accordance with the locally applicable guidelines.

12.3 Information on the collection of used electrical and electronic products

Proper disposal and appropriate recycling of this product prevents damage to the environment and danger to your personal health.



NOTICE

Disposal in domestic waste is prohibited!

In the European Union this symbol may be included on the product, the packaging or the accompanying documentation. It means that the electrical and electronic products in question must not be disposed of along with domestic waste.

To ensure proper handling, recycling and disposal of the used products in question, please note the following points:

- Hand over these products at designated, certified collection points only.
- Observe the locally applicable regulations!

Please consult your local municipality, the nearest waste disposal site, or the dealer who sold the product to you for information on proper disposal. See www.wilo-recycling.com for more information about recycling.

13 Appendix

13.1 Shrink disc tightening torques

Stainless steel mixer shaft

| Size Shrink disc inside diameter | Mixer | Mixer shaft | Thread | Tightening torque |
|--|-------|-------------|--------|----------------------|
| D62 | 5 | 71/45 | M6 | 6.8 Nm (5 ft·lb) |
| D75 | 6 | 90/56 | M8 | 16 Nm (12 ft·lb) |
| D90 | 7 | 95/67 | M8 | 16 Nm (12 ft·lb) |
| D100 | 8 | 106/71 | M8 | 16 Nm (12 ft·lb) |









wilo



Local contact at
www.wilo.com/contact

Pioneering for You

WILO SE
Wilopark 1
44263 Dortmund
Germany
T +49 (0)231 4102-0
T +49 (0)231 4102-7363
wilo@wilo.com
www.wilo.com