

Pioneering for You

Recirculation pump

Flumen OPTI-RZP 30.145-4/24 S1

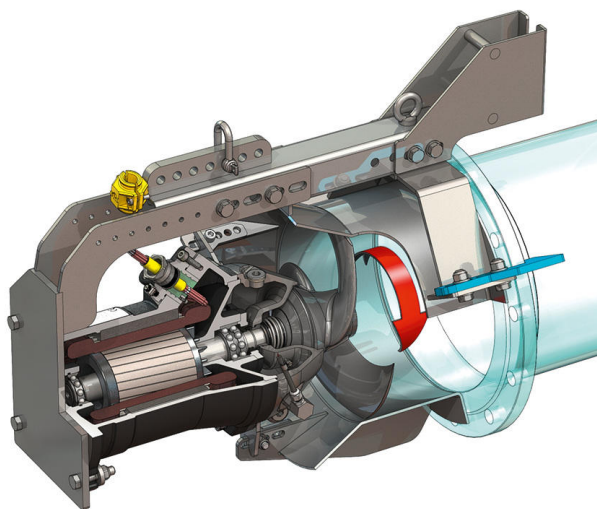
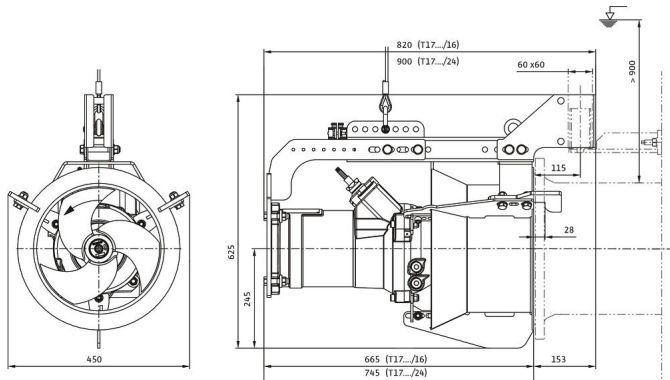
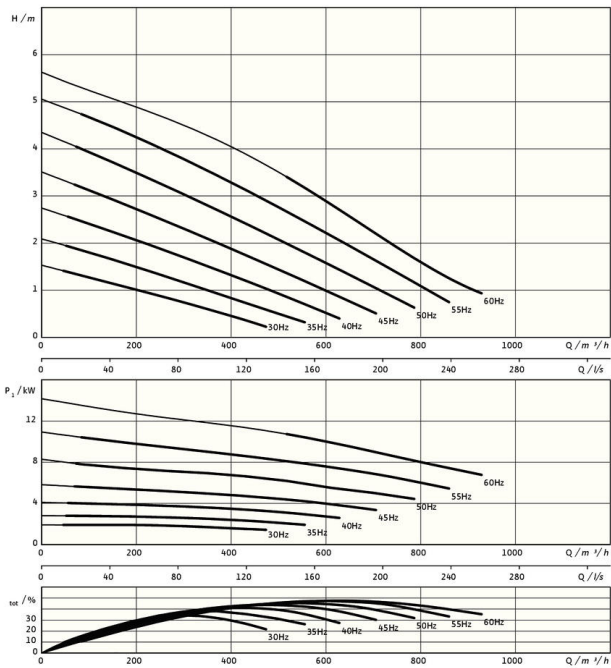

Unit

Max. weight* <i>m</i>	130 kg
Explosion protection ATEX ATEX	optional
Explosion protection FM FM	optional
Protection class motor	IP68

Propeller

Propeller model	3-blade propeller with self-cleaning hub; clogging- and entangling-free
Nominal propeller diameter <i>D_{nom}</i>	300 mm
Propeller speed <i>n</i>	1417 1/min
Transmission ratio	1.000

Filling quantities and types

Filling sealing chamber	White oil
Fill volume sealing chamber <i>V</i>	1.20 l

Motor/electronics

Motor type	T 17-4/24R (Ex)
Motor design	Submersible motor – surface-cooled
Mains connection	3~400 V, 50 Hz
Rated current <i>I_N</i>	21.00 A
Starting current – direct <i>I_A</i>	123.00 A
Starting current – star-delta <i>I_A</i>	41.00 A
Power consumption <i>P_{1 max}</i>	12.20 kW
Rated power <i>P₂</i>	10 kW
Speed original <i>n</i>	1417 1/min
Motor efficiency class	–
Efficiency <i>η_M</i>	82.0 %
Power factor <i>cos φ</i>	0.85
Min. fluid temperature <i>T_{min}</i>	3 °C
Max. fluid temperature <i>T_{max}</i>	40 °C
Max. immersion depth	20 m
Insulation class	H
Max. switching frequency <i>t</i>	15 rph
min. switching break <i>t</i>	3 min
Starting torque <i>M</i>	150 Nm
Moment of inertia	0.0134 kg/m ²
Motor bearings	1 grooved ball bearing, 1 two-row inclined ball bearing

Materials

Motor housing	5.1301, EN-GJL-250
Static gaskets	FKM
Motor shaft	1.4021, X20Cr13
Sealing chamber	1.4408, GX5CrNiMo19-11-2
Seal on the fluid side	SiC/SiC, Q1Q1VGG
Propeller	1.4408, GX5CrNiMo19-11-2
Flow housing	1.4571, X6CrNiMoTi17-12-2

*maximum weight including accessories

Subject to change without prior notice