

Pioneering for You

## Recirculation pump

### Flumen EXCEL-RZPE 30.95-6/16 S0

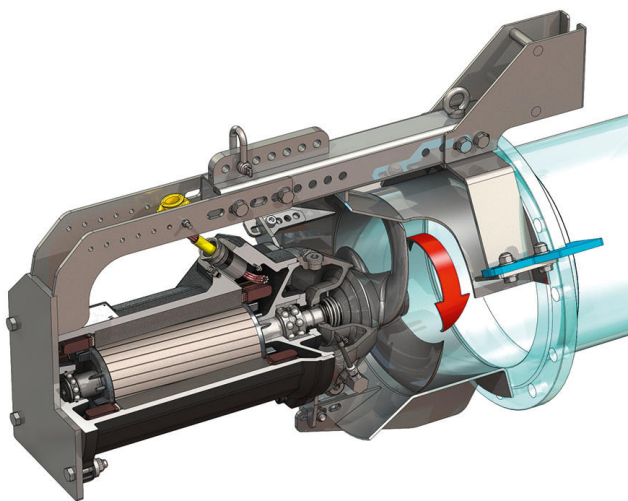
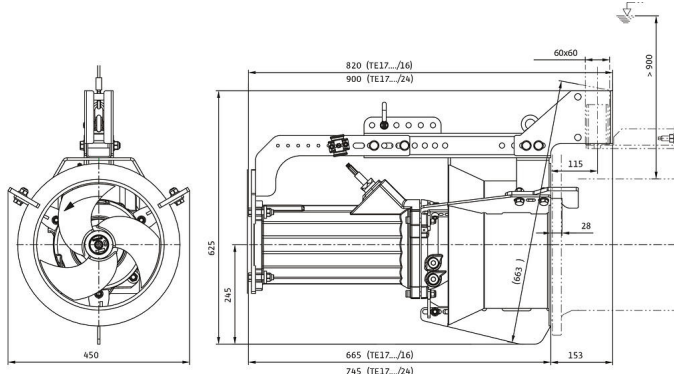
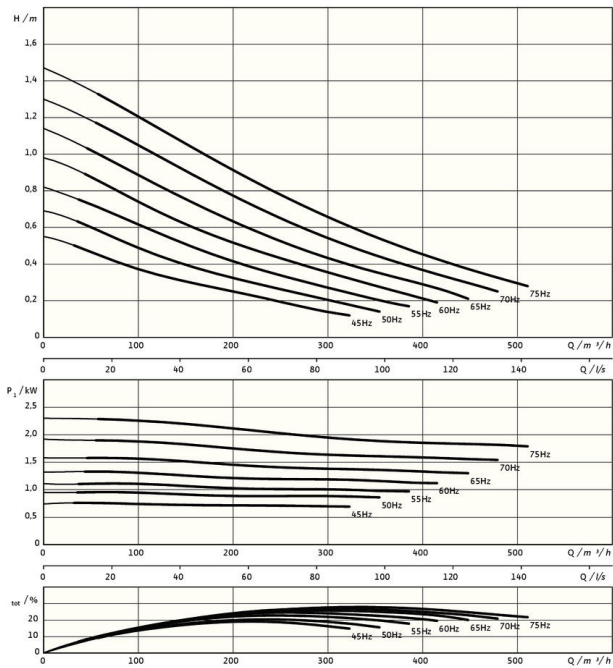

#### Unit

Max. weight* <i>m</i>	110 kg
Explosion protection ATEX ATEX	optional
Explosion protection FM FM	optional
Protection class motor	IP68

#### Propeller

Propeller model	3-blade propeller with self-cleaning hub; clogging- and entwining-free
Nominal propeller diameter <i>D<sub>nom</sub></i>	300 mm
Propeller speed <i>n</i>	941 1/min
Transmission ratio	1.000

#### Filling quantities and types

Filling sealing chamber	White oil
Fill volume sealing chamber <i>V</i>	1.20 l

#### Motor/electronics

Motor type	TE 17-6/16R (Ex)
Motor design	Submersible motor – surface-cooled
Mains connection	3~400 V, 50 Hz
Rated current <i>I<sub>N</sub></i>	4.70 A
Starting current – direct <i>I<sub>A</sub></i>	39.00 A
Starting current – star-delta <i>I<sub>A</sub></i>	13.00 A
Power consumption <i>P<sub>1 max</sub></i>	2.60 kW
Rated power <i>P<sub>2</sub></i>	2.1 kW
Speed original <i>n</i>	941 1/min
Motor efficiency class	IE3
Efficiency <i>η<sub>M</sub></i>	81.9 %
Power factor <i>cos φ</i>	0.79
Min. fluid temperature <i>T<sub>min</sub></i>	3 °C
Max. fluid temperature <i>T<sub>max</sub></i>	40 °C
Max. immersion depth	20 m
Insulation class	H
Max. switching frequency <i>t</i>	15 rph
min. switching break <i>t</i>	3 min
Starting torque <i>M</i>	80 Nm
Moment of inertia	0.0206 kg/m <sup>2</sup>
Motor bearings	1 grooved ball bearing, 1 two-row inclined ball bearing

#### Materials

Motor housing	5.1301, EN-GJL-250
Static gaskets	FKM
Motor shaft	1.4021, X20Cr13
Sealing chamber	1.4408, GX5CrNiMo19-11-2
Seal on the fluid side	SiC/SiC, Q1Q1VGG
Propeller	1.4408, GX5CrNiMo19-11-2
Flow housing	1.4571, X6CrNiMoTi17-12-2

\*maximum weight including accessories

Subject to change without prior notice