

Pioneering for You

Recirculation pump

Flumen EXCEL-RZPE 20-1.145-4/13 S1

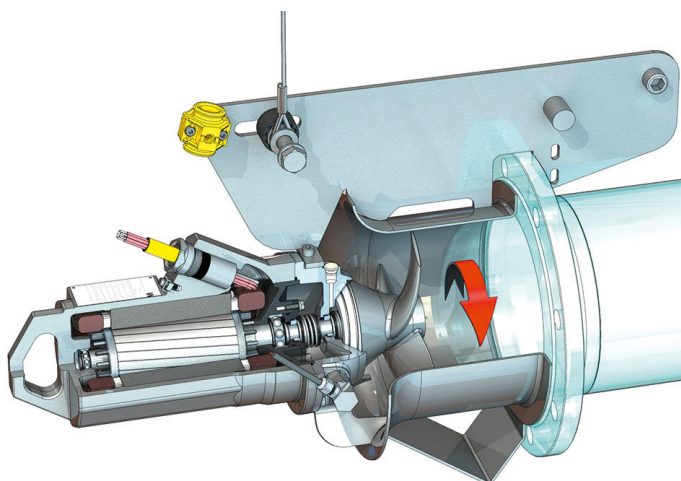
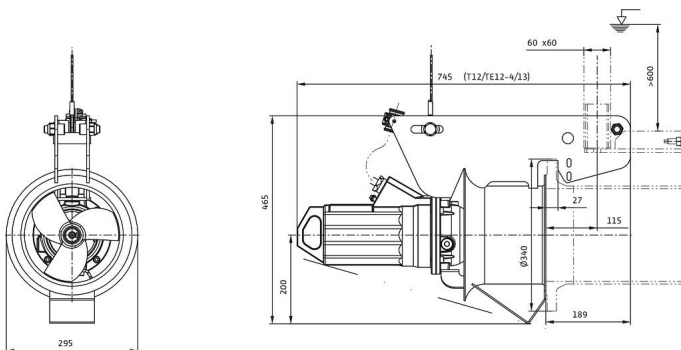
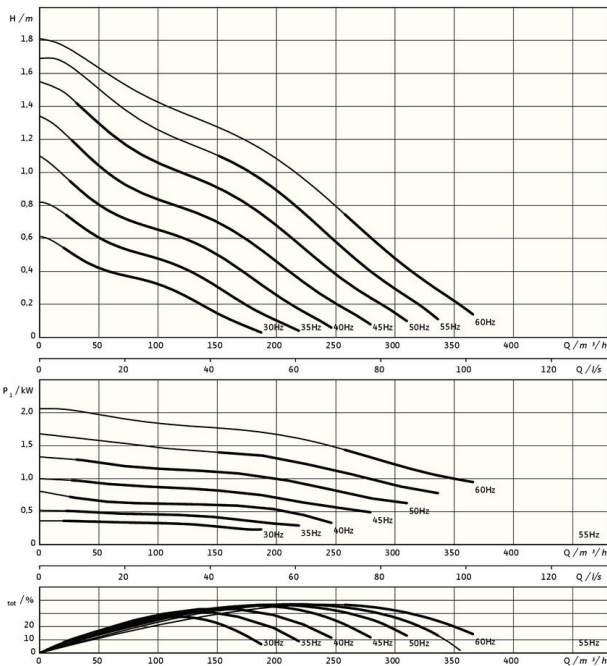

Unit

Max. weight* <i>m</i>	50 kg
Explosion protection ATEX ATEX	optional
Explosion protection FM FM	optional
Protection class motor	IP68

Propeller

Propeller model	3-blade propeller with self-cleaning hub; clogging- and entwining-free
Nominal propeller diameter <i>D_{nom}</i>	200 mm
Propeller speed <i>n</i>	1400 1/min
Transmission ratio	1.000

Filling quantities and types

Filling sealing chamber	White oil
Fill volume sealing chamber <i>V</i>	0.40 l

Motor/electronics

Motor type	TE 12-4/13GRF (Ex)
Motor design	Submersible motor – surface-cooled
Mains connection	3~400 V, 50 Hz
Rated current <i>I_N</i>	2.95 A
Starting current – direct <i>I_A</i>	14.30 A
Power consumption <i>P_{1 max}</i>	1.40 kW
Rated power <i>P₂</i>	1.1 kW
Speed original <i>n</i>	1416 1/min
Motor efficiency class	IE3
Efficiency η_M	78.8 %
Power factor $\cos \varphi$	0.69
Min. fluid temperature <i>T_{min}</i>	3 °C
Max. fluid temperature <i>T_{max}</i>	40 °C
Max. immersion depth	20 m
Insulation class	H
Max. switching frequency <i>t</i>	15 rph
min. switching break <i>t</i>	3 min
Starting torque <i>M</i>	18.3 Nm
Moment of inertia	0.0021 kg/m ²
Motor bearings	2 grooved ball bearing

Materials

Motor housing	1.4408, GX5CrNiMo19-11-2
Static gaskets	FKM
Motor shaft	1.4021, X20Cr13
Sealing chamber	1.4408, GX5CrNiMo19-11-2
Seal on the fluid side	SiC/SiC, Q1Q1VGG
Propeller	1.4408, GX5CrNiMo19-11-2
Flow housing	1.4571, X6CrNiMoTi17-12-2

*maximum weight including accessories