

Pioneering for You

wilo

Wilo-Extract FIRST ...



en Installation and operating instructions

Fig. 1

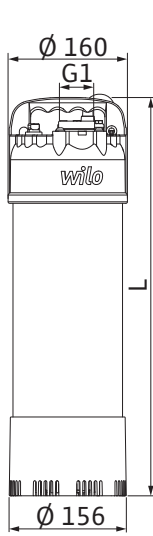

FIRST

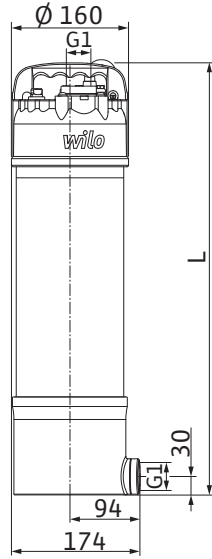

FIRST-SE

Fig. 2

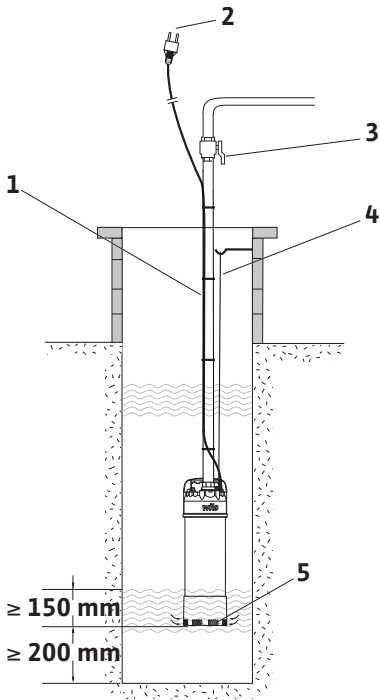

Fig. 3

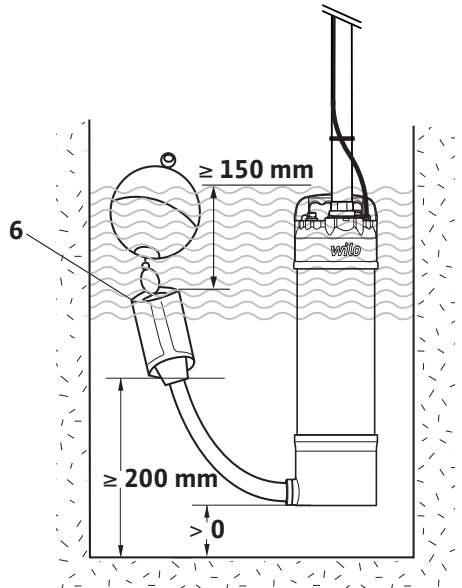

Fig. 4

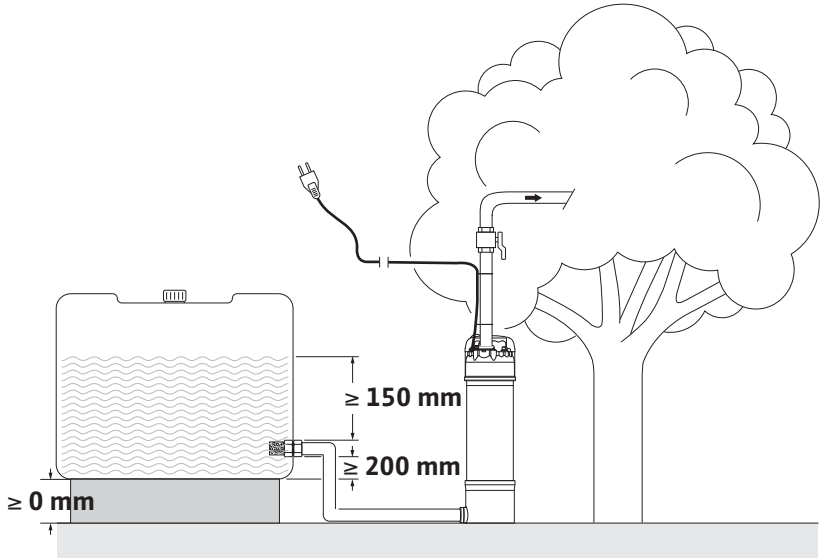
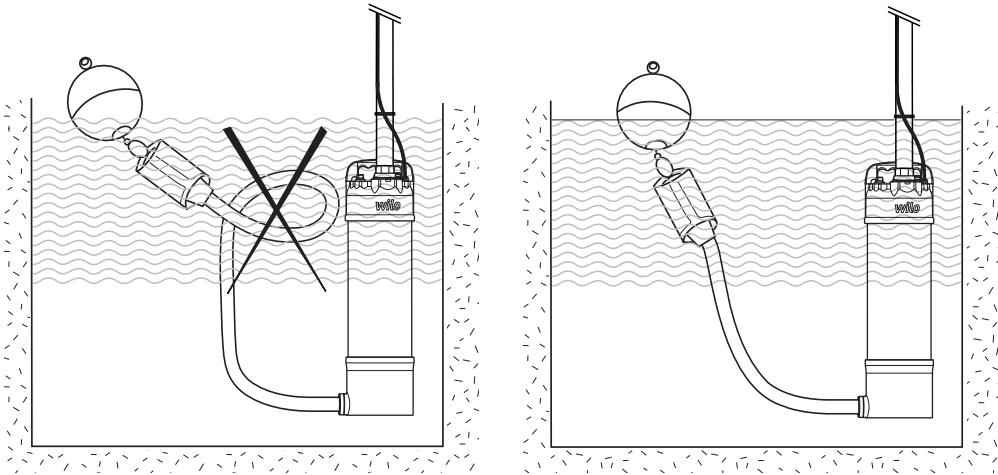

Fig. 5





1	Safety	6	6	Starting up	15
1.1	About this manual	6	6.1	Direction of rotation	15
1.2	Digital instructions	6	6.2	Operation	15
1.3	Identification of safety instructions	6	7	Maintenance	15
1.4	Personnel qualifications	7	8	Problems, causes and remedies	16
1.5	Personal protective equipment	7	9	Assembly – Disassembly	17
1.6	Transport and storage	7	10	Disposal	17
1.7	Installation	7			
1.8	Electrical connection	8			
1.9	During operation	8			
1.10	Monitoring devices	8			
1.11	Removal	8			
1.12	Maintenance tasks	9			
1.13	Operating fluid	9			
2	Product description	9			
2.1	Description	9			
2.2	Type key	9			
2.3	Technicals data	10			
2.4	Scope of Supply	10			
2.5	Accessories	10			
2.6	Product description	11			
2.7	Design of pump and motor	11			
3	Application/use	11			
3.1	Intended use	11			
3.2	Improper use	11			
4	Transport and storage	11			
5	Installation and electrical connection	12			
5.1	Installation	12			
5.2	Hydraulic connection	13			
5.3	Electrical connections	14			

1 Safety

1.1 About this manual

These instructions form part of the product. Compliance with the instructions is essential for correct handling and use:

- Read the instructions carefully before all activities.
- Keep the instructions in an accessible place at all times.
- Pass the instructions on to a subsequent owner.
- Observe all product specifications.
- Observe the markings on the product.

The language of the original operating instructions is German. All other languages of these instructions are translations of the original operating instructions.

Failure to follow the instructions will result in:

- Danger to persons or damage to property.
- The loss of claims for damages.

1.2 Digital instructions

The digital version of the instructions is available on the following product page:
<http://qr.wilo.com/519>

1.3 Identification of safety instructions

In these installation and operating instructions, safety instructions are used for material damage and personal injury. These safety instructions are illustrated differently:

- Safety instructions for personal injury start with a signal word, have a corresponding prefixed symbol and are grayed out.



DANGER

Type and source of danger!

Impacts of the danger and instructions for prevention.

- Safety instructions for material damage start with a signal word and are represented **without** a symbol.

CAUTION

Type and source of danger!

Impacts or information

Signal words

- **DANGER!**
Non-compliance causes death or serious injury!
- **WARNING!**
Non-compliance can cause (serious) injury!
- **CAUTION!**
Non-compliance can cause material damage or even total loss.

- **NOTICE!**

Useful information about handling the product

Symbols

The following symbols are used in these instructions:



General warning symbol



Warning – electrical voltage



Useful information

1.4 Personnel qualifications

- Persons aged 16 and over
- Have read and understood the installation and operating instructions

Children and persons with limited abilities in the household

This device can be used by children from 8 years of age as well as people with reduced physical, sensory or mental capacities or lack of experience and knowledge if they are supervised or instructed on the safe use of the device and they understand the dangers that can occur. Children are not allowed to play with the device. Cleaning and user maintenance must not be carried out by children without supervision.

1.5 Personal protective equipment

The articles mentioned are recommendations. The articles can be replaced with an identical article at any time. WILO SE assumes no liability for the items mentioned.

Protective equipment: Transport, installation, removal and maintenance

- Safety shoes: uvex 1 sport S1
- Protective gloves (EN 388): uvex phynomic wet

1.6 Transport and storage

- Wear protective equipment!
- Always carry the product by the handle. Never carry or pull on the connection cable!

1.7 Installation

- Wear protective equipment!
- Do not install damaged or defective products.

1.8 Electrical connection

- Do not connect products with a damaged connection cable! Have the connection cable replaced by a qualified electrician or the customer service.
- Mains connection with correctly installed protective earth conductor.
- Install the residual-current device (RCD) with 30 mA.
- Fuse protection at mains connection: max. 16 A

1.9 During operation

- The pumping of highly inflammable and explosive fluids (petrol, paraffin, etc.) in their pure form is strictly prohibited!
- If persons come into contact with the pumped fluid (accessible basins), do not commission the product.

Definition of “accessible basins”

Installation sites that can be walked on and directly accessed without tools (e.g. ladders):

- Garden ponds
- Paddling pools
- Fountains, etc.

NOTICE! The specifications applicable to swimming pools also apply to accessible basins.

1.10 Monitoring devices

The following monitoring devices must be provided by the customer if the pump is connected to a power supply grid:

Circuit breaker

- Install the circuit breaker in accordance with the manufacturer instructions. Observe local regulations.
- Further protection devices (e.g. overvoltage, undervoltage, or phase-failure relay, etc.) must be provided on-site for sensitive power supplies.

Residual-current device (RCD)

- Adhere to the regulations of the local energy supply company! We recommend using a residual-current device.
- If persons could come into contact with the product and conductive fluids, secure connection with a residual-current device (RCD).

1.11 Removal

- Wear protective equipment!
- Depending on the operating mode and duration, the housing parts become hotter than 40 °C.
 - Only touch the product by the carrying handle.
 - Allow product to cool down.
- Clean the device thoroughly.

1.12 Maintenance tasks

- Wear protective equipment!
- Only perform the maintenance work described in these installation and operating instructions.
- Carry out maintenance work in a clean, dry and well-lit location.
- Use only original parts obtained from the manufacturer. The use of any non-original parts releases the manufacturer from any liability.

1.13 Operating fluid

The oil is located in the sealing chamber. It serves to lubricate the seal on the motor and pump side.

- Absorb leakages immediately.
- If major leakages occur, contact customer service.
- If the seal is defective, the oil enters the pumped fluid and the sewer.
- Collect waste oil by type (unmixed) and dispose of it in accordance with regulations at a certified collection point.
- **Skin contact:** Rinse skin areas thoroughly with soap and water. If skin irritation occurs, consult a doctor.
- **Contact with eyes:** Remove the contact lenses. Rinse eye thoroughly with water. If eye irritation occurs, consult a doctor.
- **Ingestion:** Consult a doctor immediately! Do not induce vomiting!

2 Product description

2.1 Description

Multistage, self-venting, fully submersible pump.

Extract FIRST .. EM/A

With standard suction strainer for submerged installation above the tank/rainwater storage tank bottom.

Extract FIRST SE .. EM/A

With side inlet connecting pieces to connect a floating extractor (SE).

For submerged installation above the tank/rainwater storage tank bottom.

The self-cooling motor, through which fluid flows, also enables dry well installation outside the tank/rainwater storage tank!

2.2 Type key

Extract FIRST SE 304 EM/A	
Extract	Product family
FIRST	Series designation
SE	Type of suction [Empty] = free entrance via suction strainer SE = side entrance (side suction inlet)
3	Nominal flow in m ³ /h
04	Number of stages
EM	EM - Single phase 230V
A	Index of technical evolution

2.3 Technicals data

Extract FIRST	
Operating pressure max. [bar]	5
Minimum inlet pressure version [bar]	0.1 ... 0.5
Fluid temperatures max. (immersed) [°C]	40
Input power P_1	See nameplate
Rated current I_N	See nameplate
Rated speed [1/min]	2860
Protection index, motor	IP 68
Insulation class	F
Frequency [Hz]	50
Voltage [V]	1~230 ($\pm 10\%$)
Cable length [m]	10
Switching frequency/h max.	20
Immersion depth max. [m]	5
Solid part size max. [mm]	0,2
Sand content max. [g/m ³]	50

Outline and pipe connections (Fig. 1), start-up pressure:

Extract FIRST ...	P_2 [kW]	L [mm]	\emptyset max. [mm]	Start-up pressure [bar]
303 EM/A	0.75	527	160	2
304 EM/A	1.0	563	160	2.5
SE 303 EM/A	0.75	534	174	2
SE 304 EM/A	1.0	570	174	2.5

2.4 Scope of Supply

- Single phase pump with 10 m mains cable (H07RN-F) including shock-proof plug
- Safety rope (10 m)
- Installation and operating instructions

2.5 Accessories

Accessories must be ordered separately.

- Insulation valve
- Floating suction filter:
 - suction coarse strainer,
 - suction fine strainer

The use of new accessories is recommended.

For specifications and descriptions of accessories, see catalogue/data sheet.

2.6 Product description (Fig. 2 und 3)

1. Supply cable
2. Shock-proof plug
3. Valve
4. Safety rope
5. Suction strainer
6. Floating suction filter

2.7 Design of pump and motor

The submersible pump is based on multi-stage and centrifugal design. A mechanical seal protects the motor against the hydraulic part of the pump. The SE type model are fitted with a lateral suction support to allow the connection of floating or fixed suction filters.

The other models contain a suction strainer on the pump base.

The motor is equipped with an overheating protection which automatically switches the motor off if it overheats. After sufficient cooling, unplug the mains plug and plug it in again – the pump restarts.

The pump reacts to a lowering of the water level and switches on and off automatically.

The integrated electronics protect the pump from running dry.

If there is no withdrawal within 24 hours, the pump switches on automatically for 2-3 minutes. This is to prevent the pump from blocking.

3 Application/use

CAUTION! Possible damage of the pump. This pumps are intended for use with water only.

3.1 Intended use

Series Extract FIRST submersible pumps are suitable for the application areas following:

- For not very deep wells, tank, cistern.
- Pumping and water distribution for:
 - agricultural use (watering, irrigation),
- Pumped fluids: non polluted, potable, cold, rain waters.

3.2 Improper use

The pump is not suitable for continuous use, e.g. for the operation of fountains. (Continuous operation > 2 hrs reduces the lifetime of the pump).

The pump must not be used for emptying swimming pools.

The pump must not be used in drinking water applications.

4 Transport and storage

When receiving the material, check immediately that there has been no damage during the transport. If any defect has been stated, take the required steps with the carrier within the allowed time.

CAUTION! If the delivered material is to be installed later on, store it in a dry place and protect it from impacts and any outside influences (humidity, frost etc...).

Handle the pump carefully so as not to damage the unit prior to installation.

5 Installation and electrical connection



DANGER! Bodily injury!

Installation and electrical work in compliance with any local codes and by qualified personnel only



WARNING! Bodily injury!

Existing regulations for the prevention of accidents must be observed.



WARNING! Electrical shock hazard!

Dangers caused by electrical energy must be excluded.

National Electrical Codes, local codes and regulations must be followed.

5.1 Installation

CAUTION! Possible damage of the pump

Do not transport, hang or suspend the pump by the cable.

- The pump must be installed in frost-free place.
- Fix the safety rope in the middle of the handle in the superior part of the pump.
- Connect the delivery pipe work.
- Use rigid metal pipes to hang the pump.

In a well

- Secure the pipes with brackets at the top of the well.

In a tank

CAUTION! Possible damage of the pump!

Only operate the pump in a vertical position!

- Fix the supply cable without constraint to the delivery pipe with the appropriate bindings.
- Lower the pump and level it so that it is always immersed in water, maximum depth: 5 m and freely suspended.

CAUTION! Possible damage of the pump!

Only operate the pump in a vertical position!

- Ensure that the well diameter is always constant and allows a free lowering of the unit.
- Centre the pump in the middle of the well, tank or cistern.
- Ensure that the pump, the electric cable and the safety rope, in operation, could not rub against the well sides or any other obstacle.

NOTE: Make sure that the pump is not in direct contact with the ground! It could otherwise cause noise.



- In their final operating position, the suction strainer or the suction filter (SE version) must have a minimum distance of 200 mm to the well bottom/tank bottom.
- Ensure that the minimum water submersion is always 150 mm over the suction suction strainer of the pump when the pump is running (Fig. 2, 3, 4).
- The SE-type model can be installed out of water, because the motor is cooled by the fluid (Fig. 4).



NOTE: The pump has a valve for automatic venting in the upper part of the housing (Fig. 6, Pos. A). This valve allows the pump to prime in a very short time.

In the case of dry well installation of the SE version and generally when the upper casing is not completely covered by water, a small amount of water will leak out at this point. This is not a malfunction!

Because of the way the automatic venting works, dry installation is only recommended outdoors (Fig. 4)!

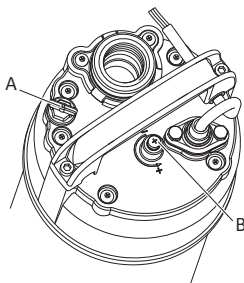

Fig. 6: Pump topl

A Automatic venting

B Pressure setting; **factory preset – DO NOT CHANGE!**

- For outdoor installation, protect the delivery pipe work, the electric box, valves, flap, electric controls from frost.
- If a floating tapping device (suction filter with hose connection) is used take care to ensure that the length of the hose is adapted to the structural conditions of the cistern (see Fig. 5). To prevent air from entering, the filter basket must not reach the surface of the water.

5.2 Hydraulic connection

CAUTION! Possible damage of the pump

During the use of SE pump, fill the section hose with water before starting the pump.

The Extract FIRST pumps are not self-priming.

- The pipework diameter cannot be inferior to the pump's one on rigid threaded steel pipework or a semi rigid polyethylene high density pipework.
- In the case of a semi rigid pipework the pump must be supported by a safety rope fixed to the carrying handle situated on the pump top.

5.3 Electrical connections



WARNING! Electrical shock hazard

The electrical connections and the inspections have to be done by a qualified electrician and comply with the applicable local standards.

The power supply of the pump must include a circuit having a residual current difference device (earth fault breaker) acting at no more than 30 mA.

In case of cord damaged, make it replace by a qualified electrician.

- Control the kind of current and the network voltage.
- Observe the specifications of the pump nameplate.

WARNING! Do not forget to connect the earth.



NOTE: The single-phase pumps have an integrated overcurrent protection.

- The pump with single-phase motor is cabled and has an integrated thermic protection.

Do not connect the pump if:

- The connection cable is damaged.
Have the connection cable replaced by a qualified electrician or the customer service.
- A standalone inverter is in use.
Stand-alone inverters are used in autonomous power supplies, e.g. solar power supply, and can generate overvoltages. Overvoltages can destroy the pump.
- A multiple plug socket or power strip is in use.
- An energy-saving plug is in use.
This reduces the energy supply to the pump and the pump may heat up too much.
- Operation on start-up controls.
The pump is not suitable for operation on a frequency converter or a soft start control.

6 Starting up

6.1 Direction of rotation

Single-phase 230 V: No reverse risk

6.2 Operation

CAUTION! Possible damage of the pump

NEVER allow the pump to run dry. The manufacturer's guarantee does not cover damage to the pump caused by dry running.

- Once again check all the electric connections, electric protection, rating of the fuse(s).

CAUTION! Possible damage of the pump

DO not exceed the nominal current of the motor.

- After switching on, the pump switches on and off several times – fully automatic venting.

NOTE: See chapter 2.3 for allowed tolerance



7 Maintenance



DANGER! Isolate from power supply before checking the pump!.

The pump does not require particular maintenance.

- Measures, if the suction strainer is obstructed and the flow rate decreases significantly:
 - Lift the pump.
 - Clean the suction strainer under water with a brush.
- The repairs on the pump and the modifications of the electric connection will be realised by a specialist or a after sales member only.

8 Problems, causes and remedies

Problems	Causes	Remedies
Pump does not start up	Inadequate voltage or voltage drop	Check voltage on start-up, an insufficient cable cross-section can cause a voltage drop that prevents the motor from operating normally.
	Motor power cable break	Measure the resistance between phases. Re-assemble the pump if required and check the cable.
	Motor protection ON	Check the current set on thermal relay and compare it to the mentioned value Important: if it trips repetitively, do not insist (look at the cause). Forcing the unit to operation can damage the motor (by overheating) in a very short time limit.
No output or a very low output	Very low voltage	Check the power supply.
	The suction strainer is obstructed	Reassemble the pump, clear and clean it.
	The valve is closed	Open the valve.
	No water or very low water level in well/tank	Check this level ; it must be at least 150 mm above the suction strainer of pump (during operating).
	Air in the pump	Check water cover and ensure minimum water cover
Very frequent starts of the pump	Leakage at pump or discharge pipe	Eliminate leakage, contact customer service if necessary.
	External bladder tank capacity is too low or insufficiently inflated	Check and adjust pressures (ON/OFF) Check tank inflation. This pressure must be 0.3 bar less than the pump starting pressure. Increase capacity with an additional tank or change the tank.
	The non return valve leaked	Contact the service.

CAUTION! Possible damage of the pump

A common cause of faults is a silted-up or choked pump. The pump without stand must hang sufficiently high above the bottom of the shaft that it is not possible for it to silt up.

ON repeated trippings of the overload protector it will be necessary to have the pump checked by a specialist or by WILO customer services.

If no solution can be found, please contact your plumbing and heating specialist or your nearest Wilo Customer Service or representative.

9 Assembly – Disassembly

CAUTION! Be careful not to mix parts.

Unplug the pump (see FIG. 9a and 9b)

10 Disposal

Your device contains valuable raw materials which can be recycled. Therefore, please take your device to your local collection point in your town or district.



Subject to technical alterations!

wilo



Local contact at
www.wilo.com/contact

WILO SE
Wilopark 1
D-44263 Dortmund
Germany
T +49(0)231 4102-0
F +49(0)231 4102-7363
wilo@wilo.com
www.wilo.com

Pioneering for You