

Pioneering for You

## Submersible mixer

### Flumen OPTI-TR 80-3.28-4/30

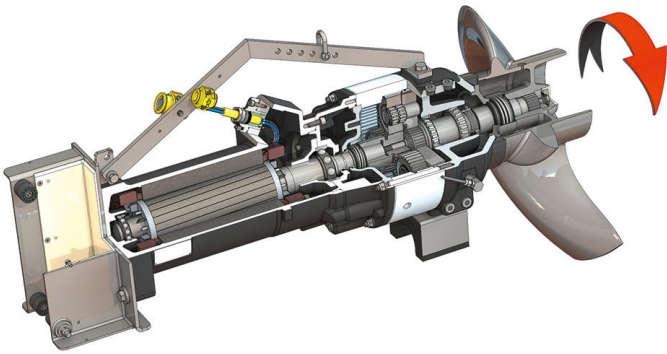

#### Unit

|   |          |
|---|----------|
| Power consumption at duty point $P_{1,1}$ | 11.20 kW |
| Max. thrust $F$                           | 3050 N   |
| Thrust to power ratio                     | 272 N/kW |
| Max. weight* $m$                          | 365 kg   |
| Explosion protection ATEX ATEX            | optional |
| Explosion protection FM FM                | optional |
| Protection class motor                    | IP68     |

#### Propeller

|                                      |  |
|--------------------------------------|--|
| Propeller model                      | 3-blade propeller with self-cleaning hub; clogging- and entwining-free |
| Nominal propeller diameter $D_{nom}$ | 800 mm   |
| Propeller speed $n$                  | 280 1/min  |
| Transmission ratio                   | 5.286  |

#### Filling quantities and types

|                                 |                 |
|---------------------------------|-----------------|
| Filling prechamber              | Gear oil CLP220 |
| Filling volume prechamber $V$   | 2.00 l          |
| Filling gear chamber            | Gear oil CLP220 |
| Fill volume gear chamber $V$    | 1.10 l          |
| Filling sealing chamber         | White oil       |
| Fill volume sealing chamber $V$ | 2.00 l          |

#### Motor/electronics

|                                     |   |
|-------------------------------------|---|
| Motor type                          | T 20-4/30R (Ex)   |
| Motor design                        | Submersible motor – surface-cooled                      |
| Mains connection                    | 3~400 V, 50 Hz  |
| Rated current $I_N$                 | 36.50 A   |
| Starting current – direct $I_A$     | 220.00 A  |
| Starting current – star-delta $I_A$ | 73.00 A   |
| Power consumption $P_{1 max}$       | 22.00 kW  |
| Rated power $P_2$                   | 18.5 kW   |
| Speed original $n$                  | 1435 1/min  |
| Motor efficiency class              | –   |
| Efficiency $\eta_M$                 | 86.0 %  |
| Power factor $\cos \varphi$         | 0.86  |
| Min. fluid temperature $T_{min}$    | 3 °C  |
| Max. fluid temperature $T_{max}$    | 40 °C   |
| Max. immersion depth                | 20 m  |
| Insulation class                    | H   |
| Max. switching frequency $t$        | 15 rph  |
| min. switching break $t$            | 3 min   |
| Starting torque $M$                 | 235 Nm  |
| Moment of inertia                   | 0.0598 kg/m <sup>2</sup>                                |
| Motor bearings                      | 1 grooved ball bearing, 1 two-row inclined ball bearing |

#### Materials

|                               |                           |
|-------------------------------|---------------------------|
| Motor housing                 | 5.1301, EN-GJL-250        |
| Static gaskets                | FKM                       |
| Motor shaft                   | 1.4021, X20Cr13           |
| Seal, gear/sealing chamber    | SiC/SiC, Q1Q1VGG          |
| Gear housing                  | 5.1301, EN-GJL-250        |
| Planetary gear                | 1.7131, 16MnCr5           |
| Hollow gear                   | 1.5216, 17MnV6            |
| Sun gear                      | 1.7131, 16MnCr5           |
| Output shaft                  | 1.4462, X2CrNiMoN22-5-3   |
| Seal, gear chamber/prechamber | FKM                       |
| Sealing chamber               | 5.1301, EN-GJL-250        |
| Seal on the fluid side        | SiC/SiC, Q1Q1VGG          |
| Seal bushing                  | 1.4571, X6CrNiMoTi17-12-2 |
| Propeller                     | 1.4408, GX5CrNiMo19-11-2  |

#### Gear

|                        |   |
|------------------------|---|
| Gear construction type | m 3.0 as per DIN 780-1:1977-05 /P10 (ISO54:1996-12); sun and planetary gears case hardened and sanded, internal gear butt-jointed |
| Gear bearings          | 3x2 needle roller bearing (planetary), two roller bearings (output shaft)   |
| Service life $L_{h10}$ | 100,000 operating hours, ISO 281:2007-02  |

\*maximum weight including accessories