

Wilo-TOP-S



en Installation and operating instructions
fr Notice de montage et de mise en service

es Instrucciones de instalación y funcionamiento

Fig. 1a:

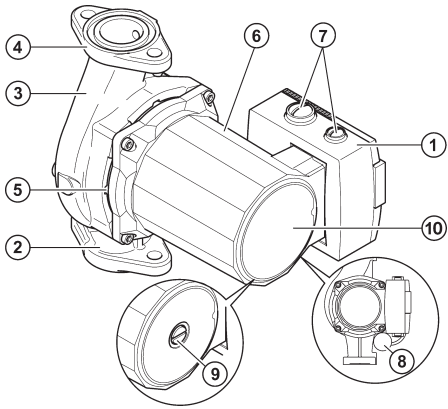

Fig. 1b:

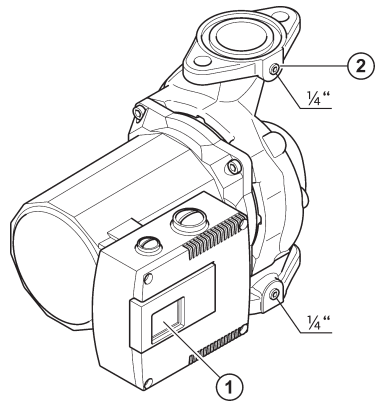

Fig. 2:

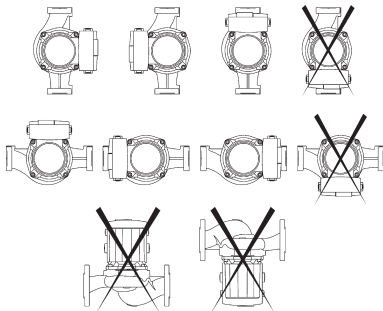

Fig. 3:

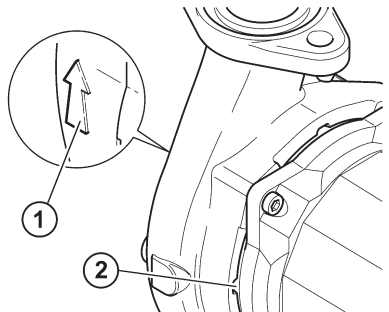

Fig. 4:

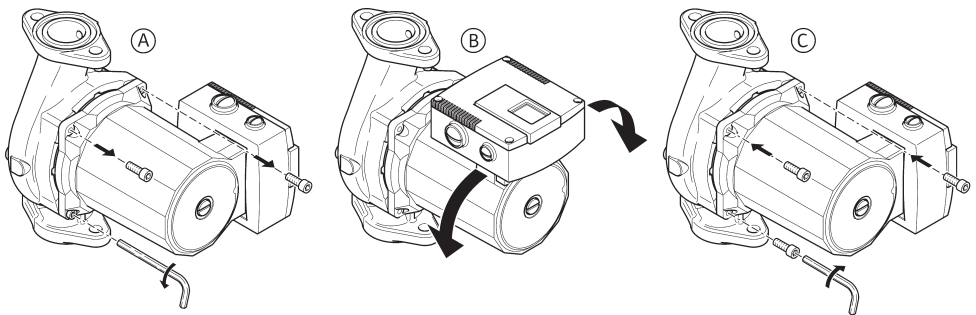

Fig. 5:

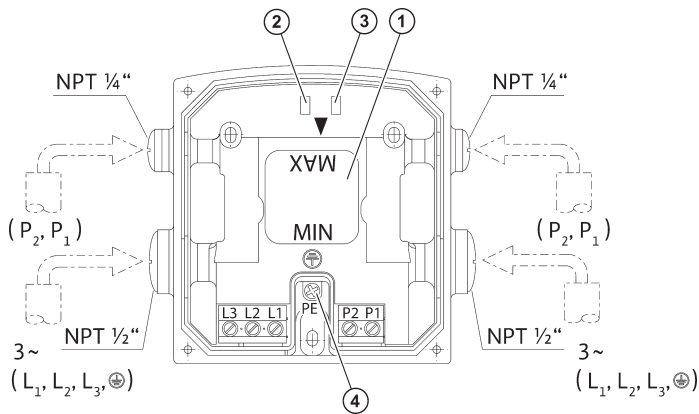

Fig. 6:

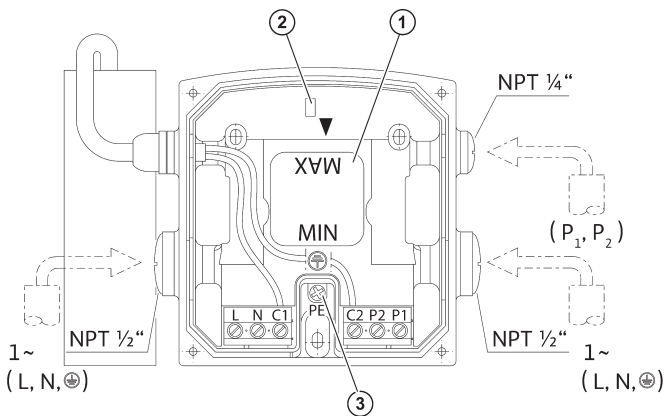

Fig. 7:

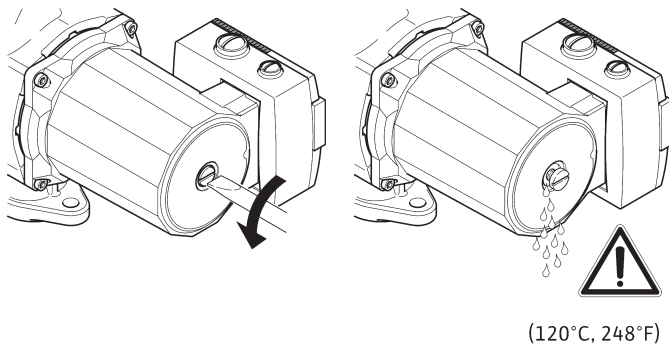

Fig. 8a:

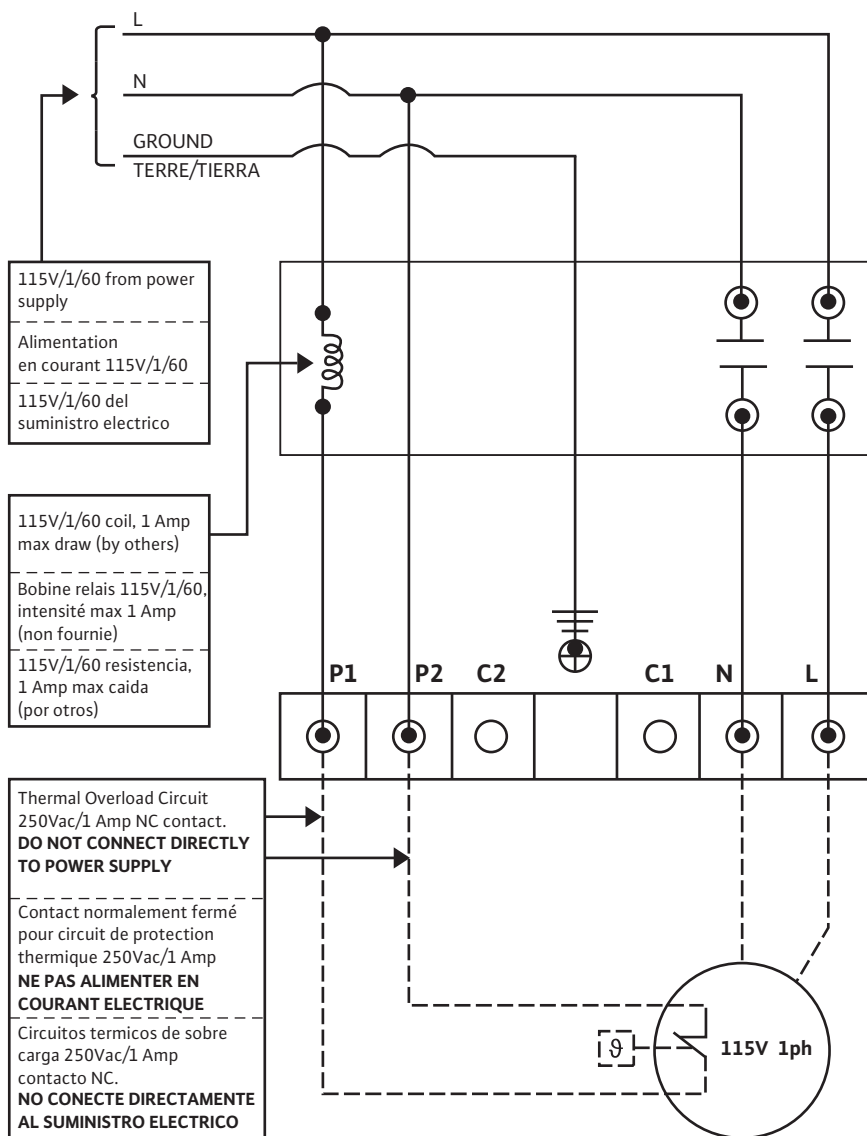

Fig. 8b:

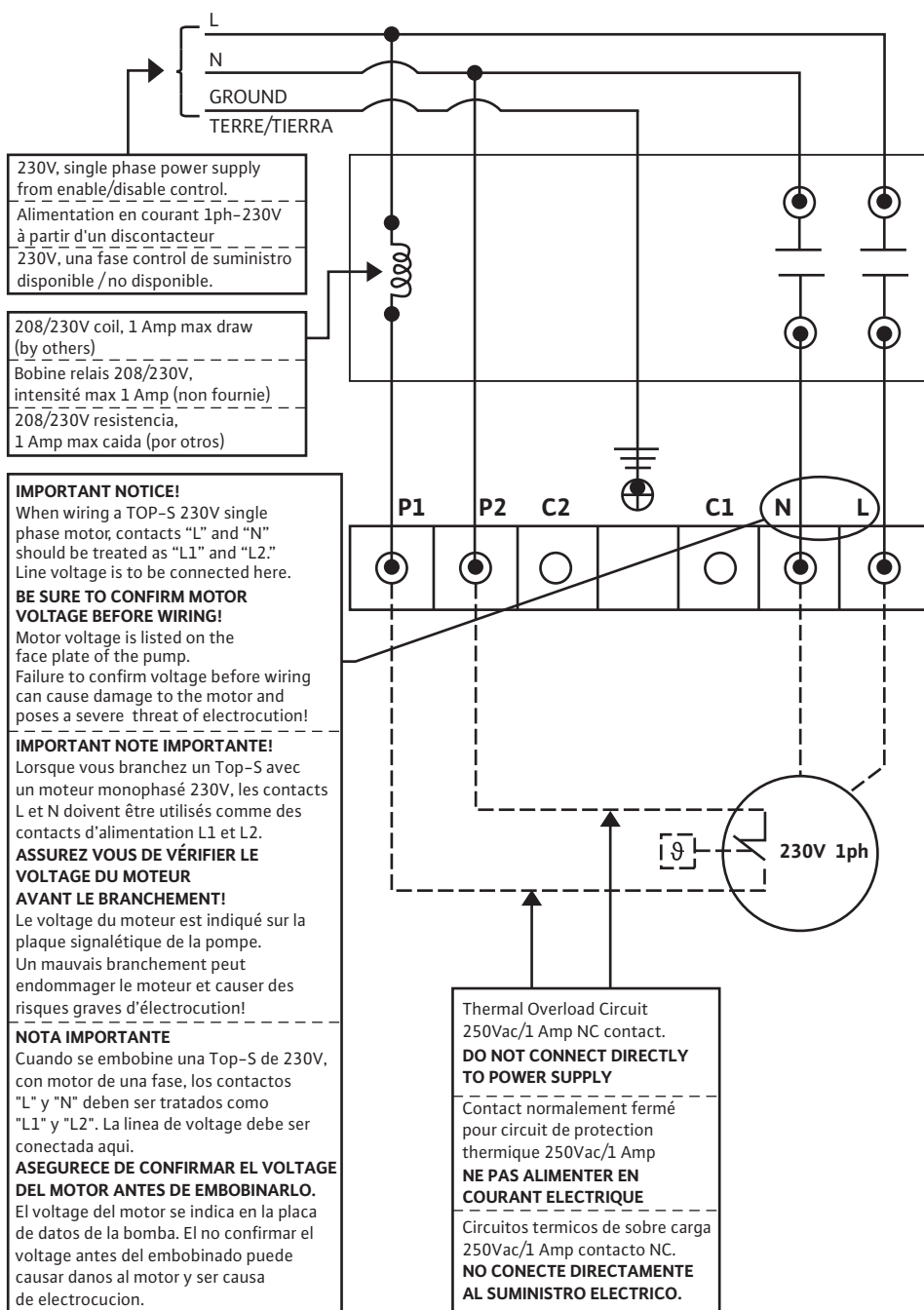
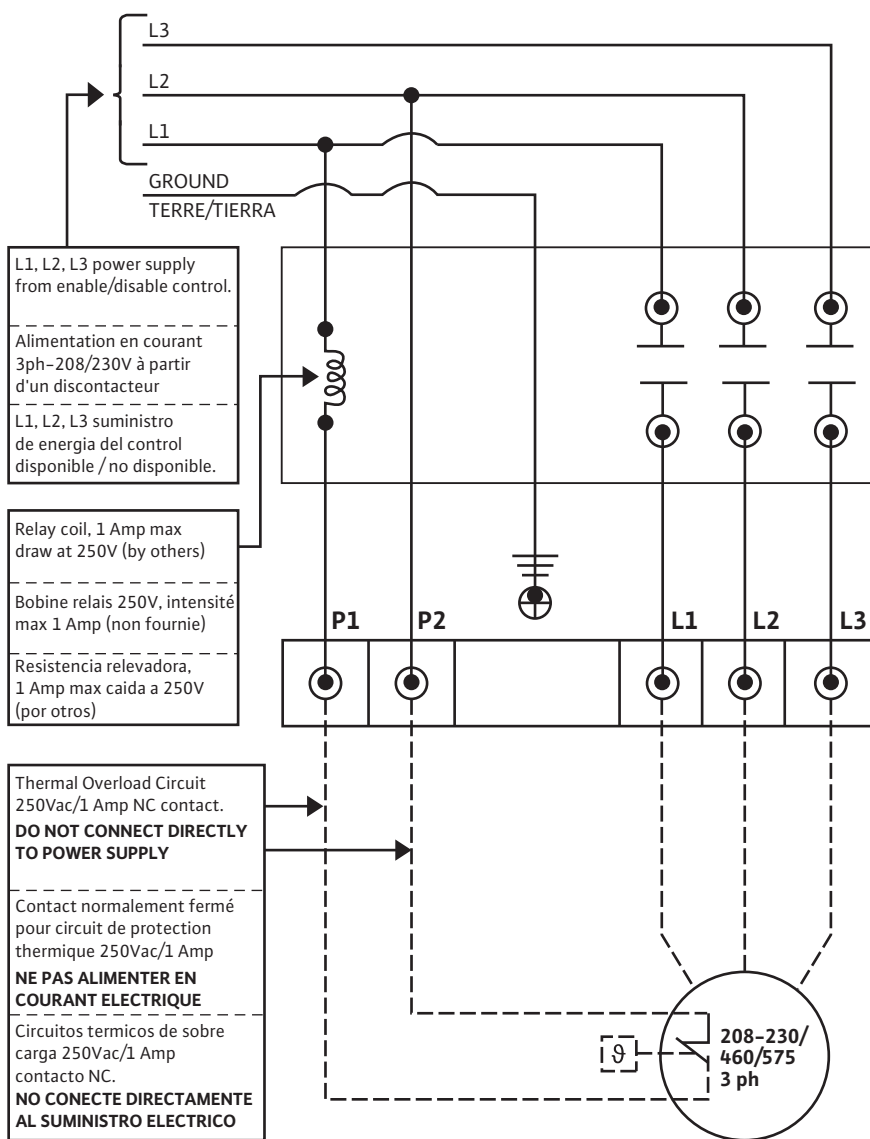

Fig. 9:



Installation and operating instructions	3
1 General	3
2 Safety	3
3 Transport and interim storage	5
4 Intended use (Application)	5
5 Technical data	6
6 Description and function	7
7 Installation and electrical connection	7
8 Start up	10
9 Maintenance /service	11
10 Faults, causes and remedies	12
11 Spare parts	14
12 Disposal	14
Notice de montage et de mise en service	15
1 Généralités	15
2 Sécurité	15
3 Transport et entreposage provisoire	17
4 Utilisation prévue (application)	18
5 Données techniques	18
6 Description et fonctionnement	19
7 Installation et raccordement électrique	20
8 Démarrage	23
9 Entretien/Service	24
10 Défaits, causes et mesures de dépannage	25
11 Pièces de rechange	27
12 Élimination	27
Instrucciones de instalación y funcionamiento	28
1 Generalidades	28
2 Seguridad	28
3 Transporte y almacenaje	30
4 Uso previsto (aplicación)	31
5 Datos técnicos	31
6 Descripción y funcionamiento	32
7 Instalación y conexión eléctrica	33
8 Puesta en marcha	36
9 Mantenimiento /Reparación	37
10 Averías, causas y soluciones	38
11 Refacciones	40
12 Desecho	40

1 General

About this document

These Installation and Operating Instructions form an integral part of the product. They must be kept close to the product and in readiness whenever required. Precise observance of these instructions is a pre-condition for use of the product for the intended purpose and for its correct operation.

These Installation and Operating Instructions conform to the relevant version of the equipment and the underlying safety standards valid at the time of going to press.

2 Safety

These instructions contain important information which must be followed when installing and operating the pump. It is therefore imperative that they be read by both the installer and the operator before the circulator is installed or started up. Both the general safety instructions in the 'Safety precautions' section and those in subsequent sections indicated by danger symbols should be carefully observed.

2.1 Symbols and signal words used in these operating instructions

Symbols:



General Safety symbol



Hazards from electrical causes



NOTE:

Signal words:

DANGER!

**Imminently hazardous situation.
Will result in death or serious injury if not avoided.**

WARNING!

The user can be exposed to (severe) injury. 'Warning' refers that harm to the user when the user is neglecting the procedure.

CAUTION!

The product is at risk of damage. 'Caution' refers to the product when the user is neglecting the procedures.

NOTE: A notice with useful information for the user in relation to the product. It attends the user to possible problems.

Information applied directly to the product, such as:

- direction of rotation arrow,
 - identifiers for connections,
 - name plate,
 - and warning sticker,
- must be strictly complied with and kept in legible condition.

2.2 Qualified Personnel

The personnel installing the pump must have the appropriate qualifications for this work. Area of responsibility, terms of reference and monitoring of the personnel are to be ensured by the operator. If the personnel are not in possession of the necessary knowledge, they are to be trained and instructed. This can be accomplished if necessary by the manufacturer of the product at the request of the operator.

2.3 Risks incurred by failure to comply with the safety precautions

Non-observance of the safety instructions can result in risk of injury to persons and damage to the environment and the product/unit. Failure to comply with the safety instructions results in the loss of any claims to damages.

Failure to comply can, for example, result in the following risks:

- danger to persons from electrical, mechanical and chemical hazards,
- damage to the environment due to leakage of hazardous materials,
- damage to property,
- failure of important product/unit functions,
- failure of required maintenance and repair procedures.

2.4 Safety consciousness on the job

The safety instructions provided in the installation manual are to be observed in accord with any national, local and municipal safety requirements.

2.5 Safety precautions for the operator

This appliance is not intended for use by persons (including children) with reduced physical, sensory or mental capabilities, or lack of experience and knowledge, unless they have been given supervision or instruction concerning use of the appliance by a person responsible for their safety.

- If hot or cold components on the product/the unit lead to any hazards, local measures must be taken to prevent their exposure.
- Leakage (i.e. from a shaft seal) of hazardous (i.e. explosive, toxic or hot) fluids must be discharged so that no danger to persons or to the environment arises. National, local and municipal statutory provisions are to be complied with.
- Highly flammable materials are always to be kept at a safe distance from the product.
- Danger from electrical current must be eliminated. National Electrical Codes, local codes and regulations must be followed.

2.6 Safety precautions for inspection and installation

The operator must ensure that all inspection and installation work is carried out by authorized and qualified specialists who have carefully reviewed these instructions.

Work on the pump/unit must be carried out only with the pump disconnected (locked out) from the electrical supply and at complete standstill. It is mandatory that the procedure described in the installation and operating instructions for shutting down the product/unit be complied with.

Immediately on conclusion of the work, all safety and protective devices must be put back in position and/or recommissioned.

2.7 Unauthorized alterations and manufacture of spare parts

Unauthorized modification and manufacture of spare parts will impair the safety of the product/personnel and will make void the third party certifications and manufacturers warranty.

Alterations to the product may only be carried out with the manufacturer's consent. The use of original spare parts and accessories authorized by the manufacturer will ensure safety. The use of any other parts may invalidate claims involving the liability of the manufacturer for any consequences.

2.8 Improper use

The operational safety of the supplied product can only be guaranteed if it is used in accordance with paragraph 4 of the operating instructions. The limits given in the catalogue or data sheet must under no circumstances be exceeded.

3 Transport and interim storage

When receiving the material, check that there has been no damage during the transport. If shipping damage has occurred, take all necessary steps with the carrier within the allowed time.



CAUTION! Outside influences may cause damages!

If the delivered material is to be installed later on, store it in a dry place and protect it from impacts and any outside influences (humidity, frost etc.).

Handle the pump carefully so as not to damage the unit prior to installation.

4 Intended use (Application)



CAUTION! Possible damage of the pump!

This pump is intended for use with water and water/glycol only.

The circulating pumps are used to circulate liquids in

- Warm and hot water heating systems,
- Cooling and cold water circuits,
- Closed circulation systems.

**WARNING! Health hazard!**

The materials of the TOP-S circulators are not designed for drinking water supply.

The pumps in the TOP-S range must not be used for drinking water.

Permissible liquids and requirements:

- Heating water according the requirements of accepted standards of water quality in heating systems.
- Water and water/glycol mixtures in a maximum ratio up to 1:1. High glycol concentration and low temperature systems may require a reassessment of the hydraulic data to compensate for the increased viscosity (please contact your Wilo representatives for more information). Use of additives (corrosion inhibitors, oxygen scavengers etc.) must be in compliance with the manufacturer instructions.
- If other fluids or additives are used, please contact Wilo for proper authorization.

5 Technical data

5.1 Type key

Example: TOP-S 2x25	
TOP	Circulator pump
S	-S = Standard Type
2	Pipe connection [inch]
25	Maximum head [ft]

5.2 Data table

Voltages (see rating plate)	1~115 V, 1~230 V, 3~208-230 V, 3~460 V, 3~575 V
Frequency	60 Hz
Power consumption	See rating plate
Speed setting	2-speed
Liquid temperature	14°F (-10 °C) up to 248°F (120°C)
Max. ambient temperature	104°F (40°C)
Max. working pressure	145 psi
Protection class	Enclosure 2

Min. pump inlet pressure [psi] at the suction side during operation:

At these liquid temps	nominal flange diameter [inch]			
	1.25	1.5	2	3
140°F (60°C)		1.8 (psi)		6.3 (psi)
194°F (90°C)		7.3 (psi)		15.4 (psi)
248°F (120°C)		29.9 (psi)		38.9 (psi)

5.3 Scope of Supply

- Complete pump
- Installation and operating instructions
- 2 flange gaskets (only for 1.25, 1.5 and 2 inch flange pumps)

5.4 Accessories

Accessories such as companion flanges must be ordered separately.

- Companion flanges (included bolts, nuts and gaskets).

6 Description and function

6.1 Pump description (see Fig. 1a)

- | | |
|---------------------|---|
| 1 Terminal box | 6 Motorhousing |
| 2 Suction side | 7 Cable entry |
| 3 Pump housing | 8 Capacitor (only for single phase pumps) |
| 4 Discharge side | 9 Venting plug (only on some types) |
| 5 Condensate outlet | 10 Rating plate |

6.2 Design of pump and motor

This wet rotor pump is designed to have all rotating parts surrounded by the liquid being pumped and is suitable for single or three phase operation (see pump rating plate). A shaft seal, which would be subject to wear and maintenance is not required. Depending on the design of the pump, the system fluid lubricates the sleeve bearings and cools both bearings and motor. The pump is maintenance-free and requires no further maintenance after the air bleeding procedure during the initial start-up (no after start-up maintenance).

6.3 Functions

Speed setting (Fig. 5 and Fig.6)

The required speed of the pump can be adjusted manually in 2 positions (Max. and Min.) by moving the switch connector to the relevant socket. Procedure see Chapter "8.2 speed setting".

Ensure power is turned off prior to changing speeds!

7 Installation and electrical connection

Installation and electrical work in compliance with any local codes and by qualified personnel only!



DANGER! Electrical shock hazard!

Dangers caused by electrical energy must be excluded.

National Electrical Codes, local codes and regulations must be followed.



WARNING! Bodily injury!

Existing regulations for the prevention of accidents must be observed.

7.1 Installation

- The pump must be installed in a dry, well ventilated and frost-free place.



CAUTION! Possible damage of the pump!

Foreign materials such as dirt and solder can effect the pump operation.

- **It is recommended that any welding and soldering work be done before installing the pump.**
- **Thoroughly flush the system prior to installing and operating the pump.**
- **Foreign material in the system resulting from construction may damage the pump and is not warrantable**

- The pump must be installed in an easily accessible position to facilitate inspection or replacement.
- The pump should never be located at the lowest point of the piping system, where dirt and sediment collect. Nor should it be located at the highest point of the piping system, where air accumulates. Please ensure at least a minimum of three pipe diameters of straight on the suction side of the pump.
- It is recommended that isolation valves be installed on the suction and discharge side of the pump.
This will save having to drain and refill the system if the pump needs replacing. The valves are to be installed so that any water that escapes cannot drip onto the pump motor or terminal box.
- An arrow on the pump housing indicates the direction of water flow (Fig. 3, Pos. 1).
- Pump must be installed with the shaft in the horizontal position in such a way that it is not stressed by the pipework (Installation positions in Fig. 2).
- It is recommended that pressure gages be installed in the suction and discharge volute flanges (Fig.1b, Pos.2) to check pump and system performance.
- In order to obtain the correct terminal box position the motor housing can be turned after removing the four allen screws (Fig. 4).



WARNING! Risk of burning!

If the pump is already installed in the system, the system must be drained or the isolating valves on both sides of the pump must be closed before the allen screws are removed as the pumped liquid may be scalding hot and/or under pressure.

Do not start the pump until the system has been filled with liquid and vented.

- Permitted terminal box positions see Fig. 2



CAUTION! Possible damage of the pump!

When rotating the motor housing, ensure the O-ring between the cartridge and pump housing (volute) does not become damaged.

- Carefully lift the pump head and rotate it so that the terminal box is in the desired position.
Replace the pump head onto the pump housing and tighten the allen screws evenly in a diagonal method.

Torque to:

- M6 7 ft lb
 - M10 22 ft lb
 - M12 45 ft lb
- After replacing, check that the rotor shaft still rotates freely.
TOP-S pumps which are equipped with vent screws can be checked as follows (Fig. 1a, Pos.9):
Remove the plug (located in the middle of the rating plate), insert a flat head screwdriver into the slot end of the shaft and turn to ensure free rotation.
TOP-S pumps without vent screws and not installed can be checked as follows:
Insert a long screwdriver in the discharge port of the pump body (Fig.1, Pos.4) until you can feel the impeller and rotate it with the tool. If the impeller does not turn easily, repeat the disassembly / reassembly process.
 - Between the stator housing and pump volute, there are three drain holes to allow condensed water to escape (Fig. 3, Pos. 2).



CAUTION! Possible damage of the pump!

The motor and condensate holes must remain free.

For units which are to be insulated, only the pump volute may be insulated.

7.2 Electrical connection



DANGER! Electrical shock hazard!

Dangers caused by electrical energy must be excluded.

- **Electrical work by a qualified electrician only!**
- **National Electrical Codes, local codes and regulations must be strictly followed.**
- **All electrical connections must be performed after the electrical supply has been switched off and secured against unauthorized switching.**
- **For safe installation and operation a proper grounding of the pump to the power supply's grounding terminals is required.**

- Suitable fused overload protection is required to protect the motor per local electrical codes.
- The operating voltage and frequency are marked on the rating plate.
- The pump must be connected with a power supply conductor equipped with a grounded plugconnection and a main power switch (Fig.8 or Fig.9).
- A minimum cable size of 14 AWG should be used (refer to the local code for wiring restrictions).



NOTE: All conductors must be suitable for at least 194°F (90 °C).

- The electrical cable must be installed so that it never touches the pipework and/or the pump and motor housing.
- The connecting cable can be fed through the cable entry either above or below the terminal box. It is advisable to install the screwed cable glands with the entrance of the conduit pointing downwards. The cable entry which is not used must be closed by a blind plug (Fig.5 and Fig.6).

- Watertight screwed cable glands and conduit connections must be used to prevent any entrance of water to the terminal box.
- Connect power as shown in Fig. 5 and Fig. 6.
 - Loosen the four terminal box screws and remove the screws and cover.
 - Feed the appropriate power supply conductor to the cable conduit on the side of the terminal box (Fig.5 or Fig.6).
 - Connect the leads of the cable according to the **L and N (for 1 ~)** or **L1, L2, and L3 (for 3 ~)** cable entry respectively and the ground lead to the  ground screw (Fig. 6, Pos. 3 for 1 ~) or (Fig. 5 Pos. 4 for 3 ~). If the power supply is connected the LED inside the terminal box will show green (Fig. 5/6, Pos. 2).
 - Replace the terminal box cover and tighten all four screws.
- The pump/installation should be grounded in compliance with local regulations. A ground fault interrupter can be used as extra protection.
- A fused plug or circuit breaker in the power line is required.
- The pump must be connected to the electrical supply via an external contactor to provide thermal overload protection. The contactor must be connected to the built-in thermal overload switch terminals P1 and P2 (potential-free normally closed contact, contact load 250 VAC/1A) to protect the pump against thermal overloading at all speeds.

Or: If the pump is protected by means of a motor starter, the starter must be set to the current consumption of the pump at the selected speed. The motor starter setting must be changed every time the pump speed is changed. The current consumption at the individual speeds is stated on the pump rating plate.

8 Start up

8.1 System filling – Venting

- Properly fill and pressurize the system with liquid.



CAUTION! Possible damage of the pump!

Never operate the pump dry.

The system must be filled before starting the pump. Ensure that all isolation valves are open.

- The pump is normally vented automatically after a short operational period. The TOP-S pumps which are equipped with a vent screw can be manually vented (Fig. 7). Please observe the following procedure:
 - Turn the power to the pump off.



WARNING! Risk of burning if the pump is touched!

Depending on the operating condition of the pump and/or installation (fluid temperature) the pump/motor can become very hot.

- Close the valve on the discharge side.



WARNING! Risk of scalding!

Depending on the fluid temperature and the system pressure, if the vent screw is completely loosened hot liquid or vapour can escape or even shoot out at high pressure.

- Place a container under the back of the pump to catch any water that may run out.
- Protect all electrical parts against the leaking water.
- Carefully loosen the vent plug with a suitable screwdriver, continue until water appears, but do not remove.
- After 30 sec. re-tighten the plug.
- Re-open isolating valve.
- Turn the power back on.



CAUTION! Possible damage of the pump!

- **Due to the internal pressure imbalance caused during the manual venting process it is possible that the pump becomes somewhat noisy. This noise should disappear once the air vent screw has been retightened and the internal pressure re-balances.**
- **The required inlet pressure must be obtained at the pump suction side.**

8.2 Setting



DANGER! Electrical shock hazard!

Never make any connections in the pump terminal box unless the electrical supply has been disconnected.

Rotation check for 3~ pump (Fig. 5)

The right direction of rotation will be indicated by a LED in the terminal box (Fig. 5, Pos 3). This LED is not lit when the direction of rotation is correct. If the direction of rotation is incorrect, the LED will show red. To check the direction of rotation briefly connect the pump. In case the direction of rotation is incorrect, proceed as follows:

- Disconnect the power supply.
- Interchange two phases(L1, L2 or L2, L3 or L1, L3) inside the terminal box.
- Restart the pump.

Speed setting for 3~ pump (Fig.5) and 1~ pump (Fig. 6)

Loosen the four terminal box screws and remove the screws and cover. Ensure the power is disconnected before removing the connector (Fig. 5/6, Pos. 1). Replace the speed selection connector by removing – rotating 180 degrees – plugging to the desired speed MAX or MIN. The speed setting can be read (MAX or MIN) through a window when the terminal box cover is closed (Fig. 1b, Pos. 1).

9 Maintenance / service

All servicing should be performed by an authorized service representative!



DANGER! Electrical shock hazard!

Dangers caused by electrical energy must be excluded. All electrical work must be performed after the electrical supply has been disconnected and secured against unauthorized switching.

WARNING! Risk of scalding!

**At high water temperatures and system pressure close isolating valves before and after the pump.
First allow pump to cool down.**

These pumps are maintenance-free, self-lubricated by the system fluid and have no seals to leak or couplings to break.

10 Faults, causes and remedies

DANGER! Electrical shock hazard!

**Dangers caused by electrical energy must be excluded.
All electrical work must be performed after the electrical supply has been disconnected and secured against unauthorized switching.**

WARNING! Risk of scalding!

**At high water temperatures and system pressure close isolating valves before and after the pump.
First allow pump to cool down.**

Problem	Causes	Remedy
Pump is connected but fails to run. The green indicator light is off. (Fig. 5/6, Pos. 2)	Electrical defect / fuse is blown.	Check / replace the fuse. Should the fuse blow several times in a row: <ul style="list-style-type: none"> • Check the pump for electrical faults. • Check the pump mains cable and electrical connection
	Ground fault interrupter has triggered.	Switch ground fault interrupter back on. Should the circuit-breaker trip several times in a row: <ul style="list-style-type: none"> • Check the pump for electrical faults. • Check the pump mains cable and electrical connection
	Faulty terminal box.	Call Customer Services.
Pump is connected but fails to run. The green indicator light is on. (Fig. 5/6, Pos. 2)	Undervoltage	Check the voltage at the pump (observe rating plate data).
	Winding damage	Call Customer Services.
	Capacitor defect (only 1~).	Replace capacitor (observe rating plate data).
	Speed selection connector not installed.	Fit speed selection connector.

Problem	Causes	Remedy	
Pump is connected but fails to run. The green indicator light is on. (Fig. 5/6, Pos. 2)	Motor is blocked, e.g. by deposits from the system fluid.	Check and if necessary verify that the rotor shaft still rotates freely. Pump with equipped vent plug: <ul style="list-style-type: none"> Remove the vent plug, insert a flat head screwdriver into the slot end of the shaft and turn to ensure free rotation, replace the vent plug Pump without equipped vent plug: <ul style="list-style-type: none"> Disassemble the motor head and check; unblock by turning the impeller if necessary. If the blockage cannot be removed, contact Customer Services.	
	Pump output too low. The green indicator light is on. (Fig. 5/6, Pos. 2)	There is a foreign body inside the pump housing or impeller.	Disassemble the pump head and remove foreign body.
	Wrong pumping direction.	Exchange the pump pressure and suction sides. Observe the arrow indicating direction on the pump housing.	
Pump output too low. The green indicator light is on. (Fig. 5/6, Pos. 2)	Shut-off valves are not fully open.	Open the shut-off valves fully.	
	Three-phase pumps only: Wrong direction of rotation. The red LED is on. (Fig. 5, Pos. 3)	Correct the electrical connection in the terminal box: <ul style="list-style-type: none"> Interchange two phases on the mains terminal. 	
	Noise in the system. The green indicator light is on. (Fig. 5/6, Pos. 2)	Air in the system.	Vent the system.
Noise in the system. The green indicator light is on. (Fig. 5/6, Pos. 2)	The pump flow is too high.	Decrease the pump output by switching to a lower speed.	
	The pump head is too high.	Check speed setting, if necessary switch to a lower speed.	
Noise in the pump. The green indicator light is on. (Fig. 5/6, Pos. 2)	Air in the pump.	Vent the pump / unit (see chapter 8.1)	
	Cavitations due to insufficient inlet pressure.	Increase system pressure within the permissible range.	
	There is a foreign body inside the pump housing or impeller.	Disassemble the pump head and remove the foreign body.	
	Shut-off valves are not fully open.	Open the shut-off valves fully.	

If the fault cannot be remedied, please contact your local heating specialist, or manufacturer's representative or Wilo customer services..

11 Spare parts

All spare parts must be ordered through your local specialist and/or Wilo Customer Services.

In order to avoid returns and incorrect orders, please specify the rating plate data for all orders.

12 Disposal

Proper disposal and recycling of this product prevents damage to the environment and risks to personal health.

1. Use public or private disposal organisations when disposing of the entire product or part of the product
2. For more information on proper disposal, please contact your local council or waste disposal office or the supplier from whom you obtained the product.



NOTE:

The pump must not be disposed of along with household waste!

wilo

Pioneering for You

WILO USA LLC
9550 W. Higgins Rd. #300
Rosemont, IL 60018
USA
P (888) 954-6872
F (888) 945-6873

WILO Canada Inc.
Bay 7 - 2915
10th Ave. N.E.
Calgary, Alberta, T2A 5L4
CANADA
P (403) 276-9456
F (403) 277-9456