

## Wilo-Control MS-L



en Installation and operating instructions



Control MS-L  
<https://qr.wilo.com/1393>



Fig. 3: Control MS-L1...-O

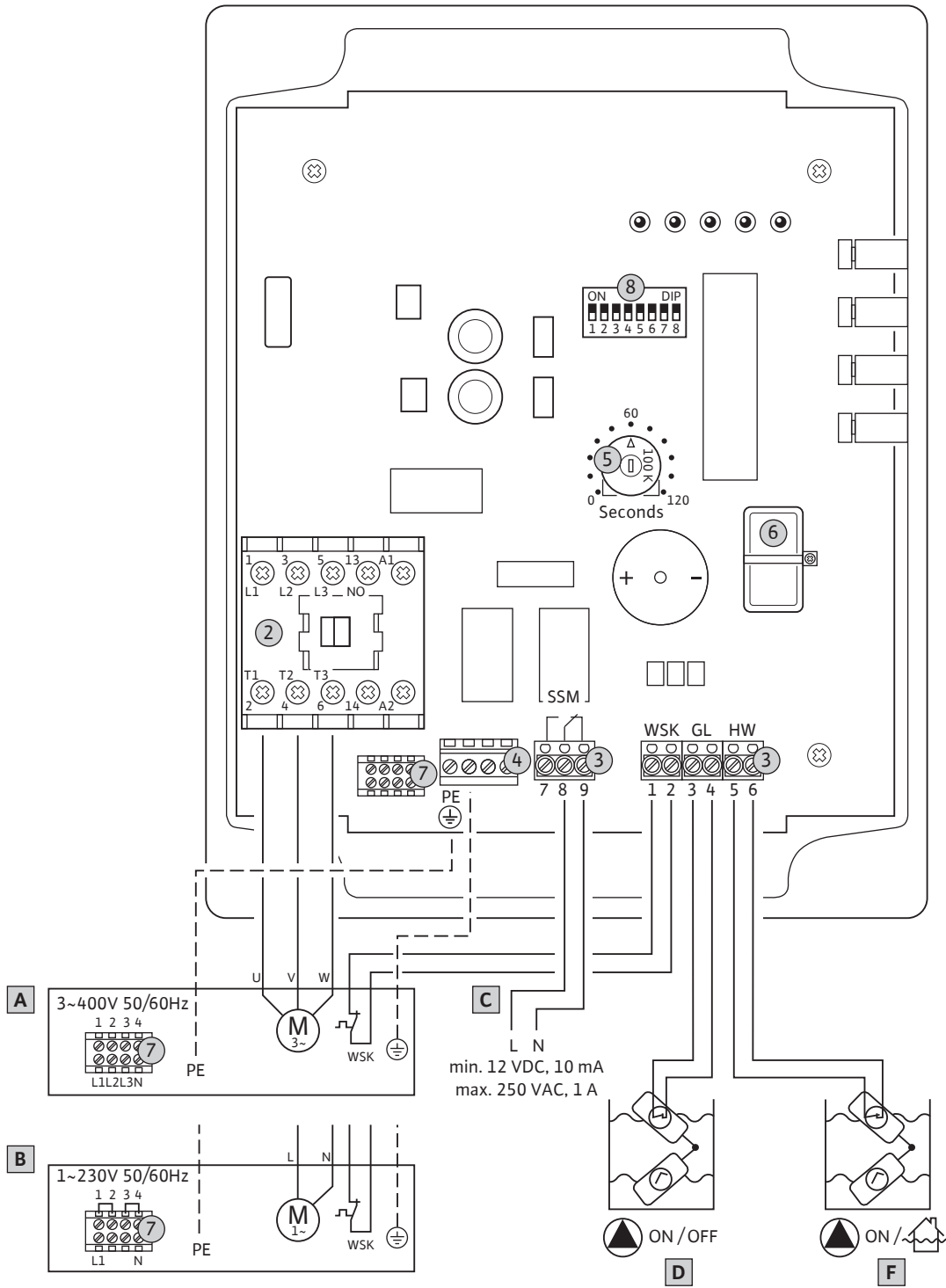

Fig. 3: Control MS-L1...-LS

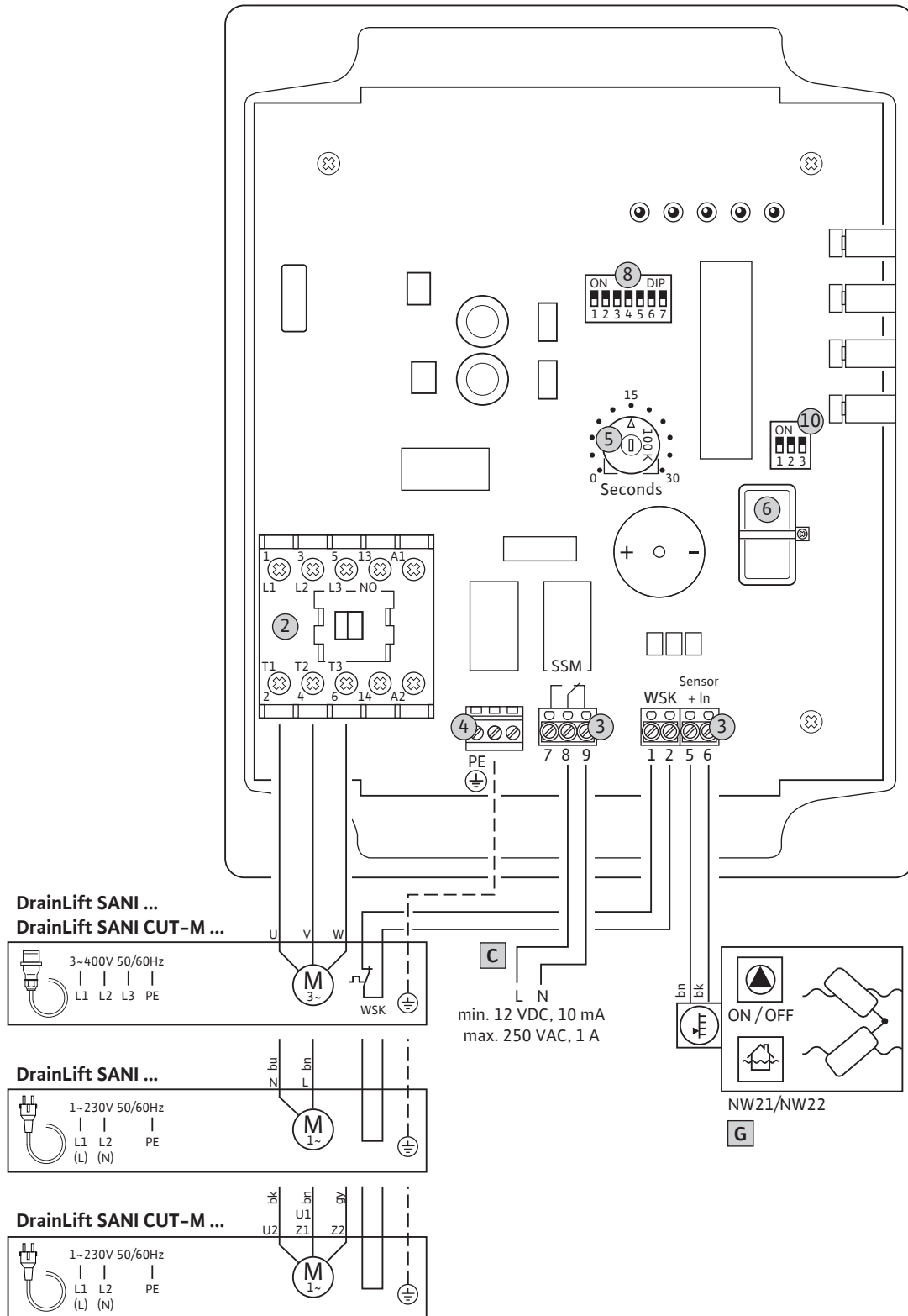





Fig. 3: Control MS-L2...-O

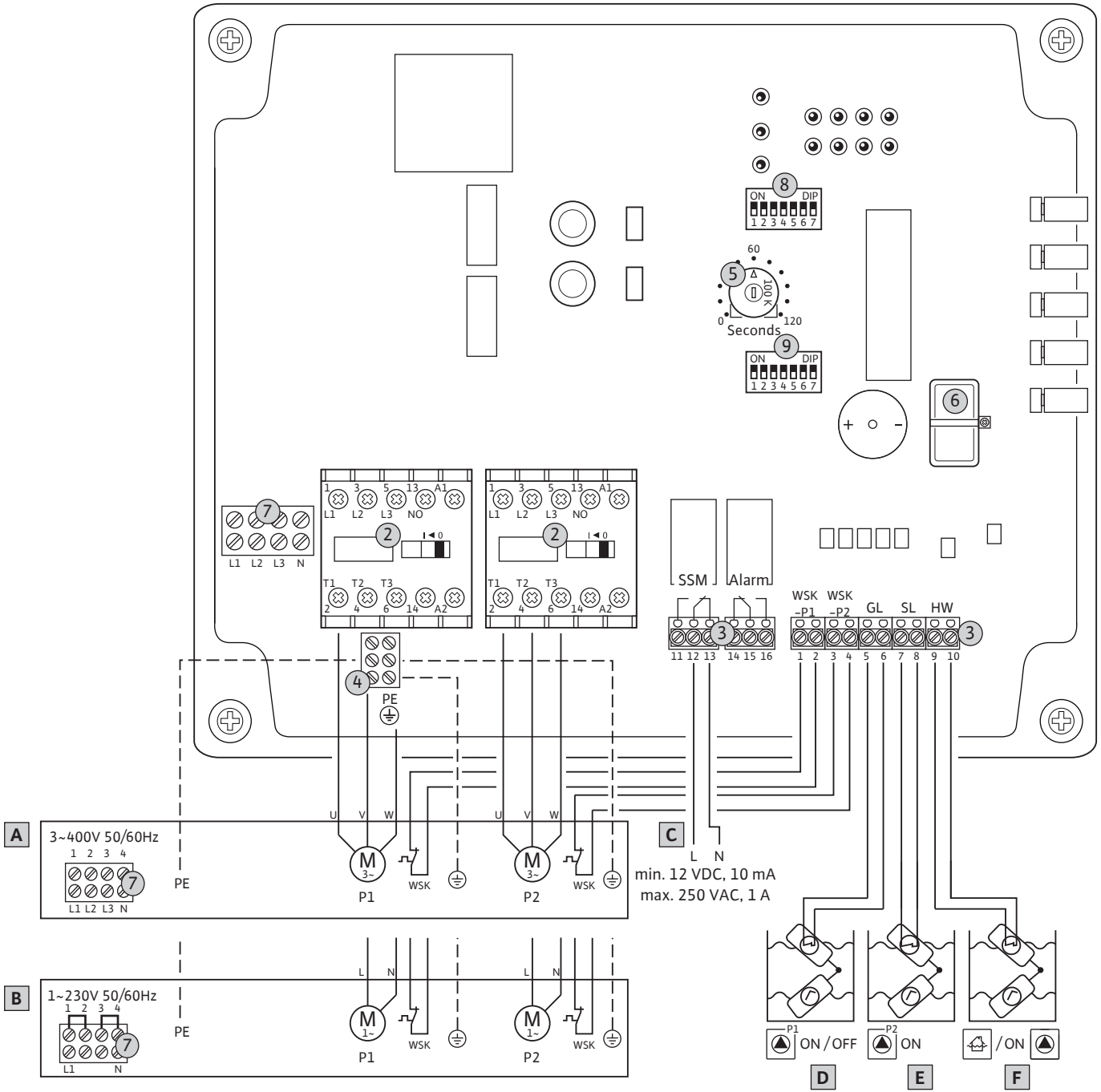
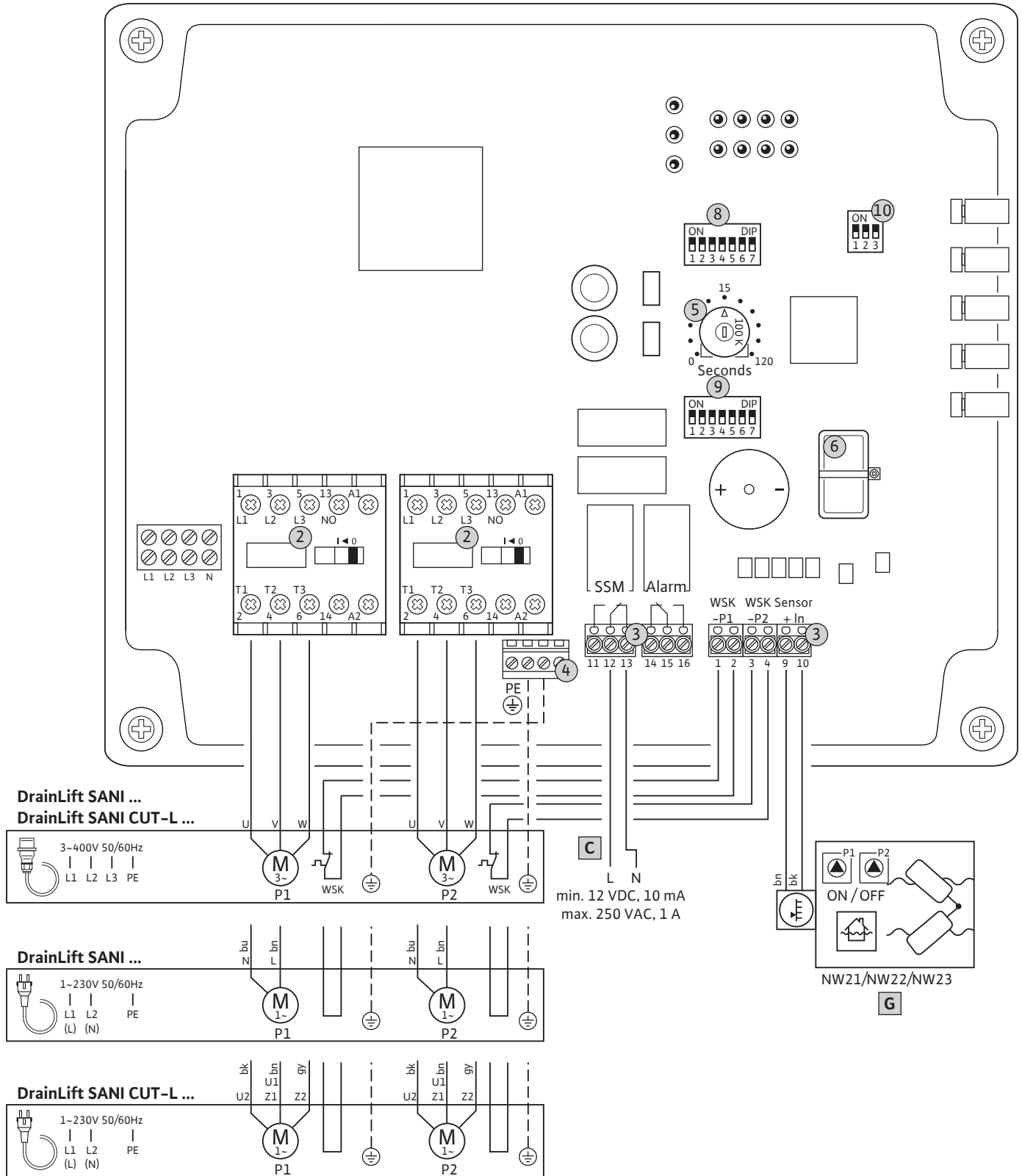



Fig. 3: Control MS-L2...-LS





## Table of contents

<b>1 General information</b> .....	<b>12</b>	8.8 During operation .....	34
1.1 About these instructions .....	12	<b>9 Shut-down</b> .....	<b>34</b>
1.2 Copyright .....	12	9.1 Personnel qualifications .....	34
1.3 Subject to change .....	12	9.2 Operator responsibilities.....	34
1.4 Exclusion from warranty and liability.....	12	9.3 Shut-down.....	34
<b>2 Safety</b> .....	<b>12</b>	9.4 Removal.....	35
2.1 Identification of safety instructions.....	12	<b>10 Maintenance</b> .....	<b>35</b>
2.2 Personnel qualifications.....	13	10.1 Maintenance intervals .....	35
2.3 Electrical work .....	14	10.2 Maintenance tasks .....	35
2.4 Monitoring devices .....	14	<b>11 Faults, causes and remedies</b> .....	<b>36</b>
2.5 Installing/dismantling.....	14	11.1 Operator responsibilities.....	36
2.6 During operation .....	14	11.2 Fault indication.....	36
2.7 Maintenance tasks.....	14	11.3 Fault acknowledgement .....	36
2.8 Operator responsibilities.....	15	11.4 Error messages .....	36
<b>3 Application/use</b> .....	<b>15</b>	11.5 Fault memory.....	36
3.1 Intended use .....	15	11.6 Further steps for troubleshooting .....	37
3.2 Improper use.....	15	<b>12 Disposal</b> .....	<b>37</b>
<b>4 Product description</b> .....	<b>15</b>	12.1 Rechargeable battery .....	37
4.1 Structure .....	15	12.2 Information on the collection of used electrical and elec- tronic products .....	37
4.2 How it works.....	16	<b>13 Appendix</b> .....	<b>37</b>
4.3 Technical data .....	16	13.1 System impedances.....	37
4.4 Inputs and outputs .....	17		
4.5 Functions.....	17		
4.6 Type key .....	17		
4.7 Operation on electronic start-up controllers .....	18		
4.8 Installation in potentially explosive atmospheres.....	18		
4.9 Scope of delivery.....	18		
4.10 Accessories .....	18		
<b>5 Transportation and storage</b> .....	<b>18</b>		
5.1 Delivery.....	18		
5.2 Transport.....	18		
5.3 Storage .....	18		
<b>6 Installation</b> .....	<b>19</b>		
6.1 Personnel qualifications.....	19		
6.2 Installation types.....	19		
6.3 Operator responsibilities.....	19		
6.4 Installation .....	19		
6.5 Electrical connection .....	20		
6.6 Functions.....	27		
<b>7 Operation</b> .....	<b>29</b>		
7.1 Operating elements.....	29		
7.2 How it works.....	30		
<b>8 Commissioning</b> .....	<b>31</b>		
8.1 Operator responsibilities.....	31		
8.2 Commissioning in explosive atmospheres .....	32		
8.3 Connection of signal transmitters within potentially ex- plosive atmospheres.....	32		
8.4 Activating the device .....	32		
8.5 Installing the rechargeable battery .....	33		
8.6 Check the direction of rotation of the connected pumps .....	33		
8.7 Start automatic mode .....	34		

## 1 General information

### 1.1 About these instructions

These instructions form part of the product. Compliance with the instructions is essential for correct handling and use:

- Read the instructions carefully before all activities.
- Keep the instructions in an accessible place at all times.
- Observe all product specifications.
- Observe the markings on the product.

The language of the original operating instructions is German. All other languages of these instructions are translations of the original operating instructions.

### 1.2 Copyright

WILO SE © 2023

The reproduction, distribution and utilisation of this document in addition to communication of its contents to others without express authorisation is prohibited. Offenders will be held liable for payment of damages. All rights reserved.

### 1.3 Subject to change

Wilo shall reserve the right to change the listed data without notice and shall not be liable for technical inaccuracies and/or omissions. The illustrations used may differ from the original and are intended as an exemplary representation of the product.

### 1.4 Exclusion from warranty and liability

Wilo shall specifically not assume any warranty or liability in the following cases:

- Inadequate configuration due to inadequate or incorrect instructions by the operator or the client
- Non-compliance with these instructions
- Improper use
- Incorrect storage or transport
- Incorrect installation or dismantling
- Insufficient maintenance
- Unauthorised repairs
- Inadequate construction site
- Chemical, electrical or electrochemical influences
- Wear

## 2 Safety

This chapter contains basic information for the individual phases of the life cycle. Failure to observe this information carries the following risks:

- Risk of personal injury from electrical, electromagnetic or mechanical influences
- Environmental damage from discharge of hazardous substances
- Damage to property
- Failure of important functions

Failure to observe the information contained herein will result in the loss of claims for damages.

**The instructions and safety instructions in the other chapters must also be observed!**

### 2.1 Identification of safety instructions

These installation and operating instructions set out safety instructions for preventing personal injury and damage to property, which are displayed in different ways:

- Safety instructions relating to personal injury start with a signal word and are **preceded by a corresponding symbol**.



## DANGER

### Type and source of the danger!

Consequences of the danger and instructions for avoidance.

- Safety instructions relating to property damage start with a signal word and are displayed **without** a symbol.

---

## CAUTION

### Type and source of the danger!

Consequences or information.

---

### Signal words

- **Danger!**  
Failure to observe safety instructions will result in serious injury or death!
- **Warning!**  
Failure to follow instructions can lead to (serious) injury!
- **Caution!**  
Failure to follow instructions can lead to property damage and possible total loss.
- **Notice!**  
Useful information on handling the product

### Markups

- ✓ Prerequisite
- 1. Work step/list
  - ⇒ Notice/instructions
  - ▶ Result

### Symbols

These instructions use the following symbols:



Danger of electric voltage



Danger – explosive atmosphere



Useful information

## 2.2 Personnel qualifications

- Personnel have been instructed on locally applicable regulations governing accident prevention.
- Personnel have read and understood the installation and operating instructions.
- Electrical work: qualified electrician  
Person with appropriate technical training, knowledge and experience who can identify and prevent electrical hazards.
- Installation/dismantling work: qualified electrician  
Knowledge regarding tools and fixation material for various structures

## 2.3 Electrical work

- Operation/control: Operating personnel, instructed in the functioning of the complete system
- Electrical work must be carried out by a qualified electrician.
- Before commencing work, disconnect the product from the mains and safeguard it from being switched on again.
- Observe applicable local regulations when connecting to the mains power supply.
- Adhere to the requirements of the local energy supply company.
- Earth the product.
- Observe technical information.
- Replace a defective connection cable immediately.

## 2.4 Monitoring devices

### Circuit breaker

The size and switching characteristics of the circuit breakers must conform to the rated current of the connected consumer. Observe local regulations.

## 2.5 Installing/dismantling

- Locally applicable laws and regulations on work safety and accident prevention must be complied with.
- Disconnect the product from the mains and secure it against being switched on again.
- Suitable fixation material must be used for the existing bearing surface.
- The product is not watertight. Select an appropriate installation site!
- Do not deform the housing during installation. Seals could leak and affect the stated IP protection class.
- The product may **not** be installed in potentially explosive areas.

## 2.6 During operation

- The product is not watertight. Comply with protection class IP54.
- Ambient temperature:  $-30 \dots +60 \text{ }^{\circ}\text{C}$ .
- Maximum humidity: 50 %, non-condensing.
- Do not open the switchgear.
- The user must notify the person in charge of every fault or irregularity immediately.
- In case of damage to the product or connection cable, switch off the product immediately.

## 2.7 Maintenance tasks

- Do not use any aggressive cleaners or scouring agents or fluids.
- The product is not watertight. Do not submerge the product in fluids.
- Only carry out maintenance tasks mentioned in these installation and operating instructions.

- Only original parts from the manufacturer may be used for maintenance and repairs. Use of parts other than the original parts releases the manufacturer from any liability.

## 2.8 Operator responsibilities

- Provide installation and operating instructions in a language which the personnel can understand.
- Make sure that the personnel has had the corresponding training for the specified work.
- Safety and information signs mounted on the device must always be legible.
- Train the personnel on how the system operates.
- Eliminate risk from electrical current.
- To ensure safe working practice, define personnel responsibilities.

Children and persons younger than 16 years or with reduced physical, sensory or mental capacities or limited experience are prohibited from handling the product! A technician must supervise persons younger than 18 years!

## 3 Application/use

### 3.1 Intended use

The switchgear is designed for level-dependent control of up to two pumps.

Intended use includes compliance with this manual. Any other use is regarded as non-compliant with intended use.

### 3.2 Improper use

- Installation in potentially explosive atmospheres
- Overflow of the switchgear

## 4 Product description

### 4.1 Structure

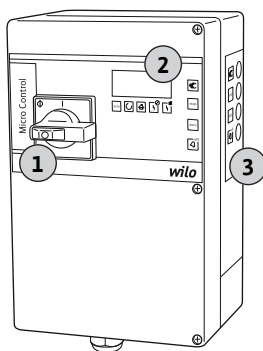

1	Main switch
2	LED indicators
3	Control panel with buttons

Microcontroller-controlled switchgear for control of one or two pumps. Separate main switch for directly switching the switchgear on and off. **NOTICE! The MS-L...-LS and MS-L...-O versions do not have a main switch!**

Fig. 1: Control MS-L 1

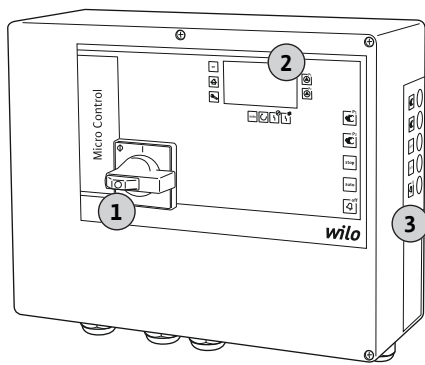

Fig. 2: Control MS-L 2

The current operating states (operation and fault) are visually indicated via LEDs on the front side. Faults are also indicated audibly via an integrated buzzer. The last error is stored in the fault memory.

LED indicators	MS-L 1...	MS-L 2...
Automatic mode	•	•
Pump operation	•	•
High water	•	•
Overload fault	•	•
Winding fault	•	•
Service interval indicator	–	•
Monitoring of certain operating parameters	–	•*

#### Key

– = not available, • = available

\* Only "LS" version

Operation is via four or five buttons on the side-mounted control panel:

- Automatic mode
- Manual mode (for each pump)
- Stop (all pumps off)
- Buzzer off/reset

## 4.2 How it works

The pumps are automatically switched on and off depending on the fill level:

- Control **MS-L .../MS-L ... -O**:
  - The level is detected via a two-position control with a float switch for each pump.
  - The high water level is detected by a separate float switch.
- Control **MS-L ... -LS**:
  - The level is detected continuously via a rod float sensor (4 ... 20 mA signal).
  - The high water level is detected by a separate switching point.

A follow-up time can be set for deactivation. When the high water level is reached, there is:

- A visual and audible alarm signal.
- Forced switch-on of all pumps.
- Collective fault signal activation.
- Activation of the external alarm signal (only Control MS-L2 ...).

## 4.3 Technical data

Date of manufacture*	See rating plate
Mains connection	See rating plate
Mains frequency	50/60 Hz
Max. current consumption per pump	See rating plate
Max. rated power per pump	See rating plate
Pump activation type	direct
Ambient/operating temperature	–30 ... +60 °C
Storage temperature	–30 ... +60 °C
Max. relative humidity	50 %, non-condensing
Protection class	IP54
Electrical safety	Pollution degree II
Control voltage	24 V=
Housing material	UV-resistant polycarbonate

Details about the Hardware version (HW) and Software version (SW) can be found on the rating plate!

\*The date of manufacture is stated in accordance with ISO 8601: JJJJww

- JJJJ = year
- W = abbreviation for week
- ww = calendar week



#### 4.4 Inputs and outputs

Inputs/outputs	Control MS-L 1...	Control MS-L 1...-O	Control MS-L 1...-LS	Control MS-L 1...-C...-LS	Control MS-L 2...	Control MS-L 2...-O	Control MS-L 2...-LS
----------------	-------------------	---------------------	----------------------	---------------------------	-------------------	---------------------	----------------------

##### Inputs

Float switch for level detection	1	1	-	-	2	2	-
Float switch for detecting the high water level	1	1	-	-	1	1	-
Rod float switch for level measurement including high water level	-	-	-	1	-	-	-
Analogue input 4 to 20 mA for level measurement with rod float sensor	-	-	1	-	-	-	1
Input for thermal winding monitor with bimetallic sensor.	1	1	1	1	2	2	2

##### Outputs

Potential-free changeover contact for the collective fault signal	1	1	1	1	1	1	1
Potential-free changeover contact for an external alarm signal	-	-	-	-	1	1	1

##### Key

1/2 = number of inputs and outputs, - = not available

**NOTICE! PTC sensors cannot be connected!**

Output contact load:

- Minimum: 12 VDC, 10 mA
- Maximum: 250 VAC, 1 A

#### 4.5 Functions

The switchgear is equipped with the following functions. All functions are switched off at the factory. The functions must be switched on as required.

	Control MS-L 1...	Control MS-L 1...-O	Control MS-L 1...-LS	Control MS-L 1...-C...-LS	Control MS-L 2...	Control MS-L 2...-O	Control MS-L 2...-LS
Internal buzzer	•	•	•	•	•	•	•
Pump kick	•	•	•	•	•	•	•
Service interval indicator	-	-	-	-	•	•	•
Monitoring operating parameters	-	-	-	-	-	-	•
Follow-up time	•	•	•	•	•	•	•
Adjustable switching points for pump ON and high water*	-	-	•	-	-	-	•

##### Key

• = available, - = not available

\* A set of parameters is set at the factory. The switching points can be adjusted via further parameter sets, if necessary. Further information about the possible switching points can be found in the installation and operating instructions of the corresponding lifting unit.

#### 4.6 Type key

Example: Wilo-Control MS-L 2x4kW-DOL-T4-X	
MS	Micro Control switchgear for fixed speed pumps
L	Level-dependent control of pumps to drain objects
2x	Max. number of pumps that can be connected
4kW	Max. permissible rated power ( $P_2$ ) per pump
DOL	Activation type of connected pump: Direct
T4	Mains connection version: <ul style="list-style-type: none"> <li>• Without: 3P+N+PE</li> <li>• T4: 3P+PE</li> </ul>

### Example: Wilo-Control MS-L 2x4kW-DOL-T4-X

X	<p>Version:</p> <ul style="list-style-type: none"> <li>• Without = standard version with main switch</li> <li>• O = without main switch, without plug (mains isolator to be provided by the customer!)</li> <li>• LS = version for lifting units without main switch, with cable and plug</li> </ul>
---	--

4.7	<b>Operation on electronic start-up controllers</b>	Connect the switchgear directly to the pump and the mains. Intermediate switching of additional electronic start-up controllers, e.g. a frequency converter, is not permitted!
4.8	<b>Installation in potentially explosive atmospheres</b>	The switchgear does not have its own explosion protection class. <b>Do not</b> install the switchgear in potentially explosive areas!
4.9	<b>Scope of delivery</b>	<p><b>Standard version and MS-L...-O version</b></p> <ul style="list-style-type: none"> <li>• Switchgear</li> <li>• 2x reducing seals for threaded cable gland</li> <li>• 2x assembled jumper wires for mains connection</li> <li>• Rechargeable battery for mains-independent alarm signals</li> <li>• Installation and operating instructions</li> </ul> <p><b>“MS-L...-LS” version for lifting units</b></p> <ul style="list-style-type: none"> <li>• Switchgear with 1.5 m connection cable and plug: <ul style="list-style-type: none"> <li>– 1~230 V: Shockproof plug or CEE32-plug</li> <li>– 3~400 V: CEE16-plug</li> </ul> </li> <li>• Rechargeable battery for mains-independent alarm signals</li> <li>• Installation and operating instructions</li> </ul>
4.10	<b>Accessories</b>	<ul style="list-style-type: none"> <li>• Float switch for drainage and sewage</li> <li>• Signal lamp</li> <li>• Flash light</li> <li>• Horn</li> </ul>
5	<b>Transportation and storage</b>	
5.1	<b>Delivery</b>	<ul style="list-style-type: none"> <li>• After delivery, check product and packaging for defects (damage, completeness).</li> <li>• Defects must be noted on the freight documentation.</li> <li>• Defects must be notified to the transport company or the manufacturer on the day of receipt of shipment. Claims cannot be asserted if the notification of defects takes place at a later date.</li> </ul>
5.2	<b>Transport</b>	

## CAUTION

### Damage to property due to wet packaging!

Wet packaging may tear. If unprotected, the product may fall on the ground and be irreparably damaged.

- Carefully lift wet packaging and replace it immediately!

5.3	<b>Storage</b>	<ul style="list-style-type: none"> <li>• Clean control device.</li> <li>• Close housing apertures, ensuring they are sealed watertight.</li> <li>• Impact-resistant and watertight packaging.</li> <li>• Pack the switchgear in dustproof and watertight packaging.</li> <li>• Maintain storage temperature: -30 ... +60 °C, max. relative humidity: 50 %, non-condensing.</li> <li>• Frost-proof storage at a temperature of 10 °C to 25 °C with relative humidity of 40 ... 50 % is recommended.</li> <li>• Avoid the formation of condensation at all times.</li> <li>• All open threaded cable glands must be sealed to prevent water ingress into the housing.</li> <li>• Attached cables should be protected against kinking, damage, and ingress of moisture.</li> <li>• To prevent damage to the components, protect the switchgear from direct sunlight and heat.</li> <li>• Clean the switchgear after storage.</li> </ul>
-----	----------------	--

- If there has been water ingress or condensation has formed, have all the electronic components tested for correct function. Contact customer service.
- 6 Installation**
- Check the switchgear for damage caused during transport. Do **not** install defective switchgears!
  - Observe the local guidelines for the design and operation of electronic controls.
- 6.1 Personnel qualifications**
- Electrical work: qualified electrician  
Person with appropriate technical training, knowledge and experience who can identify and prevent electrical hazards.
  - Installation/dismantling work: qualified electrician  
Knowledge regarding tools and fixation material for various structures
- 6.2 Installation types**
- Wall fixation
- 6.3 Operator responsibilities**
- The installation location is clean, dry and free of vibration.
  - The installation location is overflow-proof.
  - The switchgear is not exposed to direct sunlight.
  - Installation location outside of potentially explosive atmospheres.
- 6.4 Installation**



### DANGER

#### Risk of explosion if the switchgear is installed in potentially explosive areas!

The switchgear does not have its own explosion protection class and must always be installed outside of potentially explosive areas! The connection must be made by a qualified electrician.

- Level sensor and connection cable provided by the customer.
  - While laying the cables, ensure that there is no tension, no kinking and no pinching that could damage the cable.
  - Check the cable cross-section and length for the routing type chosen.
  - Seal unused threaded cable glands.
  - Ensure that the following ambient conditions are adhered to:
    - Ambient/operating temperature: -30 ... +60 °C
    - Relative humidity: 40 ... 50 %
    - Max. relative humidity: 50 %, non-condensing
- 6.4.1 Basic advice on fixing the switchgear in place**
- Various structures can be used for installation (concrete wall, mounting rail, etc.). For this reason, the fixation material for the relevant construction must be provided by the customer and the following information must be observed:
- To prevent cracks in the masonry and chipping of the construction material, ensure sufficient clearance to the edge of the structure.
  - The depth of the borehole depends on the length of the screws. Drill the borehole approx. 5 mm deeper than the screw length.
  - Drilling dust impairs retention force. Always blow the borehole clean or vacuum it out.
  - Do not damage the housing during installation.
- 6.4.2 Installation of switchgear**
- Attach the switchgear to the wall with four screws and wall plugs:
- Max. screw diameter: 4 mm
  - Max. screw head diameter: 7 mm
  - ✓ Switchgear is disconnected from the mains and is voltage-free.
  - ✓ "LS" version for lifting units: There is a socket available within a radius of 1 m around the switchgear.
1. Mark boreholes at the installation site.
    - drilling distances (W×H) MS-L 1: 129×238 mm
    - drilling distances (W×H) MS-L 2: 288×200 mm
  2. Drill and clean the mounting holes in accordance with the specifications of the fixation material.
  3. Loosen the screws on the cover and open the cover at the side.

4. Attach the lower part to the wall with the fixation material.  
Check the lower part for deformations! Realign deformed housing (e.g. by placing alignment plates below it) to ensure the housing cover closes securely. **NOTICE! If the cover does not close correctly, the protection class is compromised!**
5. Close the cover and fasten it with the screws.
  - ▶ Switchgear installed. Next steps: Connect the power supply, pumps and signal transmitters.  
**NOTICE! The Control MS-L...-LS is pre-wired to the lifting unit.**

#### 6.4.3 Level control

##### Control MS-L.../MS-L...-O

Install a level control device for the automatic control of the pumps. Connect one float switch per pump for this purpose. The float switches must be installed according to the system's installation plan. Please observe the following points:

- The float switches can move freely in the operating space (pump chamber, tank)!
- Do **not undercut** the minimum water level of the pumps!
- Do **not exceed** the switching frequency of the pumps!

##### Control MS-L...-LS

The rod float sensor is installed in the lifting unit at the factory. No further float switches are required.

##### Control MS-L...-C...-LS

The rod float switch is installed in the lifting unit at the factory. No further float switches are required.

#### 6.4.4 High water alarm

##### Control MS-L.../MS-L...-O

Install a separate float switch for detecting the high water level. If there is an alarm, a **forced switch-on** of all pumps occurs!

##### Control MS-L...-LS

A switching point is stored in the set of parameters for detecting the high water level. No separate float switch is required. If there is an alarm, a **forced switch-on** of all pumps occurs!

##### Control MS-L...-C...-LS

The high water level is monitored by the rod float switch. A separate switching point is set for the high water level. No additional float switch is required. If there is an alarm, a **forced switch-on** of all pumps occurs!

#### 6.5 Electrical connection



##### DANGER

##### Risk of fatal injury due to electrical current!

Improper conduct when carrying out electrical work can lead to death due to electric shock!

- Electrical work must be carried out by a qualified electrician!
- Observe local regulations!



##### DANGER

##### Risk of explosion if signal transmitters are installed in potentially explosive areas!

The switchgear does not have an intrinsically safe circuit for connecting the signal transmitters. The signal transmitters must always be installed outside of potentially explosive areas! The connection must be made by a qualified electrician.



**NOTICE**

- Depending on the system impedance and the maximum connections/hour of the connected consumers, voltage fluctuations and/or drops may occur.
- When using shielded cables, attach the shielding to the earth rail on one side of the control device.
- Always have connection carried out by a qualified electrician.
- Observe the installation and operating instructions for the connected pumps and signal transmitters.

- The mains connection current and voltage must be as stated on the rating plate.
- Execute fuse protection on the mains side in accordance with the local guidelines.
- If circuit breakers are used, the switching characteristics should be selected according to the connected pump.
- Follow local guidelines if residual-current devices (RCD, type A, sinusoidal current, universal-current-sensitive) are installed.
- Route connection cable in accordance with the local guidelines.
- Do not damage the connection cable during routing or installation.
- Earth the switchgear and all electrical consumers.

**6.5.1 Overview of terminals and components**

Fig. 3: Terminals and components

Connection terminals	
<b>A</b>	Mains connection: Three-phase current
<b>B</b>	Mains connection: Single-phase current
<b>C</b>	Collective fault signal connection (SSM)
<b>D</b>	Float switch connection for pump 1 level measurement
<b>E</b>	Float switch connection for pump 2 level measurement
<b>F</b>	Float switch connection for high water
<b>G</b>	Connection for lifting unit sensors (MS-L ... -LS)

Components	
<b>1</b>	Main switch, in the cover
<b>2</b>	Motor contactor
<b>3</b>	Terminal strip: Sensors
<b>4</b>	Terminal strip: Earth (PE)
<b>5</b>	Potentiometer for follow-up time
<b>6</b>	Slot 9 V rechargeable battery
<b>7</b>	Terminal strip: Mains connection
<b>8</b>	DIP switch <b>1</b>
<b>9</b>	DIP switch <b>2</b>
<b>10</b>	DIP switch <b>3</b> : Setting the switching points (only MS-L ... -LS)

**6.5.2 DIP switch**

The switchgear is equipped with DIP switches. These DIP switches are used to switch various functions on/off.

Description	DIPs	Control MS-L 1...	Control MS-L 1...-O	Control MS-L 1...-LS	Control MS-L 1...-C...-LS	Control MS-L 2...	Control MS-L 2...-O	Control MS-L 2...-LS
<b>DIP switch 1</b> , above the potentiometer								
Motor protection: Adjustment rated current	1-5	•	•	•	•	•	•	•

Description	DIPs	Control MS-L 1...	Control MS-L 1...-O	Control MS-L 1...-LS	Control MS-L 1...-C...-LS	Control MS-L 2...	Control MS-L 2...-O	Control MS-L 2...-LS
Pump kick: On/Off	6	•	•	•	•	•	•	•
Internal buzzer: On/Off	7	•	•	•	•	•	•	•
Pre-selected mains voltage: 1~230 V or 3~400 V	8	•	•	–	–	–	–	–

**DIP switch 2**, below the potentiometer

Pre-selected mains voltage: 1~230 V or 3~400 V	1	–	–	–	–	•	•	–
Monitoring operating parameters	1-3	–	–	–	–	–	–	•
Specifying the service intervals	4/5	–	–	–	–	•	•	•
Activating/deactivating the connected pumps	6/7	–	–	–	–	•	•	•

**DIP switch 3**, left next to the buttons

Setting the switching points	1-3	–	–	•	–	–	–	•
------------------------------	-----	---	---	---	---	---	---	---

### Key

- = available , – = not available
- DIP on: DIP top (ON)
- DIP off: DIP bottom (OFF)

## 6.5.3 Switchgear mains connection

### CAUTION

#### Risk of material damage due to incorrectly set mains voltage!

The switchgears Control MS-L ... and MS-L ... -O are suitable for connection to the mains voltages 1~230 V and 3~400 V. The switchgears are set to the mains voltage 3~400 V at the factory. Install the two cable bridges on the mains terminal strip for connection to the mains voltage 1~230 V. Incorrect connection destroys the switchgear!

The switchgear Control MS-L ... -LS is only suitable for the stated mains voltage!

### Control MS-L ... : Mains connection 1~230 V, with main switch

Insert the connection cables laid by the customer through the threaded cable glands and secure. Connect the wires **to the main switch** as per connection diagram.

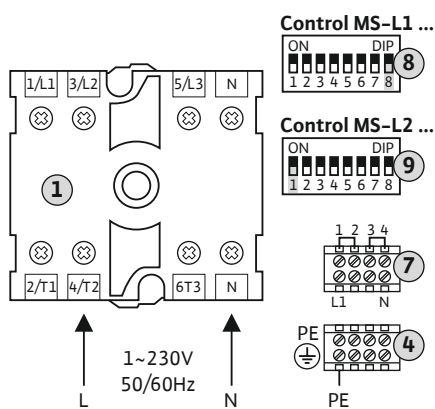

Fig. 4: Mains connection 1~230 V with main switch

1	Main switch
4	Terminal strip: Earth
7	Terminal strip: Mains connection
8	DIP switch 1
9	DIP switch 2

#### NOTICE! Install two cable bridges on the mains terminal strip: Terminal 1/2 and terminal 3/4.

- Cable: 3-core
- Terminals: 4/T2 (L), N (N)
- Connect the protective earth conductor (PE) to the terminal strip: earth (⊕).
- Pre-selected mains voltage:
  - Control MS-L1 ... : DIP switch 1, DIP 8: **OFF**
  - Control MS-L2 ... : DIP switch 2, DIP 1: **OFF**

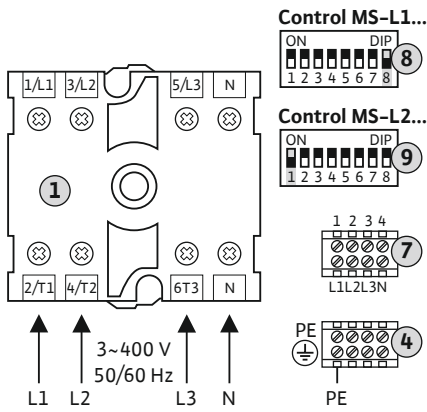

Fig. 5: Mains connection 3~400 V with main switch

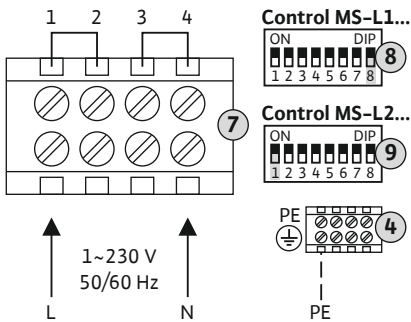

Fig. 6: Mains connection 1~230 V without main switch

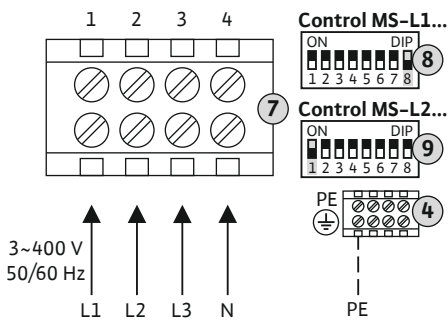

Fig. 7: Mains connection 3~400 V without main switch

### Control MS-L ... : Mains connection 3~400 V, with main switch

1	Main switch
4	Terminal strip: Earth
7	Terminal strip: Mains connection
8	DIP switch 1
9	DIP switch 2

#### NOTICE! Do not install any cable bridges on the mains terminal strip!

- Cable: 5-core
- Terminals: 2/T1 (L1), 4/T2 (L2), 6/T3 (L3), N (N)  
There must be a clockwise rotating field!
- Connect the protective earth conductor (PE) to the terminal strip: earth (⊕).
- Pre-selected mains voltage:
  - Control MS-L1 ... : DIP switch 1, DIP 8: ON
  - Control MS-L2 ... : DIP switch 2, DIP 1: ON

### Control MS-L ... -O: Mains connection 1~230 V, without main switch

Insert the connection cables laid by the customer through the threaded cable glands and secure. Connect the wires to the terminal strip according to the connection diagram. **WARNING! Mains isolator to be provided by the customer!**

4	Terminal strip: Earth
7	Terminal strip: Mains connection
8	DIP switch 1
9	DIP switch 2

#### NOTICE! Install two cable bridges on the mains terminal strip: Terminal 1/2 and terminal 3/4.

- Cable: 3-core
- Terminals: 1 (L), 4 (N)
- Connect the protective earth conductor (PE) to the terminal strip: earth (⊕).
- Pre-selected mains voltage:
  - Control MS-L1 ... : DIP switch 1, DIP 8: OFF
  - Control MS-L2 ... : DIP switch 2, DIP 1: OFF

### Control MS-L ... -O: Mains connection 3~400 V, without main switch

4	Terminal strip: Earth
7	Terminal strip: Mains connection
8	DIP switch 1
9	DIP switch 2

#### NOTICE! Do not install any cable bridges on the mains terminal strip!

- Cable: 5-core
- Terminals: 1 (L1), 2 (L2), 3 (L3), 4 (N)  
There must be a clockwise rotating field!
- Connect the protective earth conductor (PE) to the terminal strip: earth (⊕).
- Pre-selected mains voltage:
  - Control MS-L1 ... : DIP switch 1, DIP 8: ON
  - Control MS-L2 ... : DIP switch 2, DIP 1: ON

### Control MS-L ... -LS: with plug, for lifting units

Mains connection is established by inserting the plug into a socket:

- 1~230 V: Shock-proof socket (Type E or Type F) or CEE32 socket
- 3~400 V: CEE16-socket

Install the socket in an overflow-proof manner in a radius of 1 m from the switchgear.

### 6.5.4 Mains connection, pump

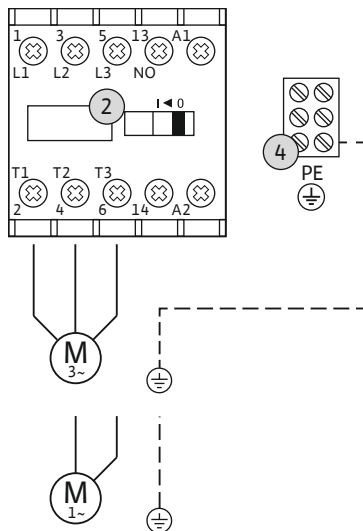

Fig. 8: Pump connection

**NOTICE! DrainLift SANI CUT... (1~):** The capacitors for start and operation are installed in the switchgear.

### 6.5.5 Adjust motor current monitoring



Fig. 9: DIP switch 1: Adjust motor current monitoring

### 6.5.6 Switch on pumps (only Control MS-L2...)



Fig. 10: DIP switch 2: Switch on pumps



## NOTICE

### Power supply and pump connection rotating field

The rotating field is routed from the mains connection directly to the pump connection.

- Check the required rotating field of the pumps to be connected (clockwise or counter-clockwise).
- Observe the installation and operating instructions of the pumps.

2	Motor contactor
4	Earth terminal

Insert the connection cables laid by the customer through the threaded cable glands and secure. Connect the wires to the contactor as per the connection diagram:

#### Control MS-L.../MS-L...-O

- Terminal assignment **1~230 V**  
L = 4/T2, N = 6/T3, PE = earth terminal
- Terminal assignment **3~400 V**  
U = 2/T1, V = 4/T2, W = 6/T3, PE = earth terminal

#### Control MS-L...-LS

- Terminal assignment **1~230 V**  
L = 4/T2, N = 2/T1, PE = earth terminal  
bn = 4/T2, bu = 2/T1, PE = earth terminal
- Terminal assignment **3~400 V**  
U = 2/T1, V = 4/T2, W = 6/T3, PE = earth terminal  
bn = 2/T1, bk = 4/T2, gy = 6/T3, PE = earth terminal

#### Control MS-L...-LS with DrainLift SANI CUT... 1~

- Terminal assignment **1~230 V**  
U2 = 2/T1, U1/Z1 = 4/T2, Z2 = 6/T3, PE = earth terminal  
bk = 2/T1, bn = 4/T2, gy = 6/T3, PE = earth terminal

The electronic motor current monitoring monitors the rated current of the connected pump. Set rated current according to rating plate:

- Set rated current via DIPs 1–5 on DIP switch 1.
- Minimum rated current: 1.5 A. All DIPs are in the “OFF” position.
- The current value is increased by the value of the respective DIP by activating the individual DIPs (“ON” position).
- Max. rated current: 12 A.

DIP	1	2	3	4	5
Current value	0.5 A	1.0 A	2.0 A	3.0 A	4.0 A

Example: required rated current 7.5 A  
1.5 A + 2.0 A (DIP 3) + 4.0 A (DIP 5) = 7.5 A

The connected pumps are switched on via DIPs 6 and 7 on DIP switch 2:

- The factory setting for both DIPs is “OFF”. Level control dependent activation of the pumps is not possible.
- Switch on pump 1: Set DIP 6 to “ON”.
- Switch on pump 2: Set DIP 7 to “ON”.



### 6.5.7 Connection, thermal motor monitoring

#### Control MS-L1.../MS-L...-O

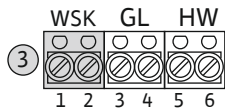

#### Control MS-L1...-LS

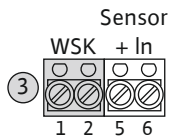

#### Control MS-L2.../MS-L...-O



#### Control MS-L2...-LS

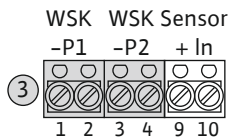

Fig. 11: Terminal strip sensors: thermal motor monitoring

### 6.5.8 Connection of signal transmitter for level control device

## CAUTION

### Property damage due to external voltage!

An external voltage which is applied destroys the component.

- Do not apply external voltage.

Connect one thermal motor monitoring device with bimetallic sensors per pump. Do not connect a PTC sensor!

Insert the connection cables laid by the customer through the threaded cable glands and secure. Connect the wires to the terminal strip according to the connection diagram.

Switchgear	Pump 1	Pump 2
Control MS-L1...	Terminal 1/2	
Control MS-L2...	Terminal 1/2	Terminal 3/4

**NOTICE! If a winding monitor is connected, remove the converter bridge installed at the factory!**

#### Lifting units DrainLift SANI... and SANI CUT...

The lifting units with a single-phase current connection have internal motor monitoring. The „WSK“ terminals are bridged at the factory.

## CAUTION

### Property damage due to external voltage!

An external voltage which is applied destroys the component.

- Do not apply external voltage.

**Control MS-L1 .../MS-L ... -O****Control MS-L1 ... -LS****Control MS-L1 ... -C ... -LS****Control MS-L2 .../MS-L ... -O****Control MS-L2 ... -LS**

Fig. 12: Terminal strip sensors: Level detection connection

### 6.5.9 High water alarm connection

**Control MS-L1...****Control MS-L2...**

Fig. 13: Terminal strip sensors: High water alarm

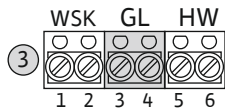
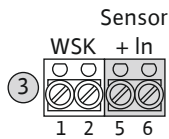
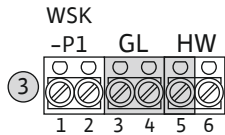
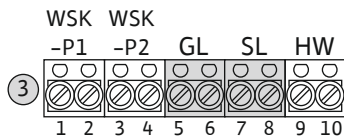
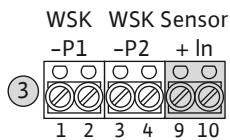
**Control MS-L.../MS-L...-O**

Connect float switch for level measurement. Level detection with a level sensor or electrodes is not possible!

Insert the connection cables (provided by the customer) through the threaded cable glands and secure them. Connect the wires to the terminal strip according to the connection diagram.

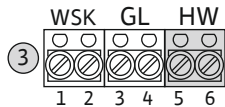
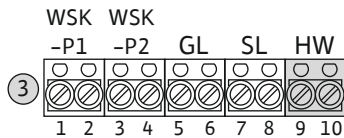
Switchgear	Base load (GL)	Peak load (SL)	Sensor
Control MS-L1.../MS-L1...-O	Terminal 3/4	–	–
Control MS-L2.../MS-L2...-O	Terminal 5/6	Terminal 7/8	–

**Control MS-L...-LS**

A rod float sensor is used for the level measurement. The sensor is installed in the lifting unit at the factory and connected to the switchgear.

Switchgear	Base load (GL)	Peak load (SL)	Sensor
Control MS-L1...-LS	–	–	Terminal 5/6
Control MS-L2...-LS	–	–	Terminal 9/10

**Control MS-L...-C...-LS**

A rod float switch is used for the level measurement. The float switch is installed in the lifting unit at the factory and connected to the switchgear.

Switchgear	Base load (GL)	Peak load (SL)	Sensor
Control MS-L1...-C...-LS	–	–	Terminal 3/4/5

## CAUTION

### Property damage due to external voltage!

An external voltage which is applied destroys the component.

- Do not apply external voltage.

**Control MS-L.../MS-L...-O**

Install a separate float switch for monitoring the high water level:

- Open: no high water alarm
- Closed: High water alarm

Insert the connection cables laid by the customer through the threaded cable glands and secure. Connect the wires to the terminal strip according to the connection diagram.

Switchgear	High water alarm (HW)
Control MS-L1...	Terminal 5/6
Control MS-L2...	Terminal 9/10

**NOTICE! A monitoring device for the high water level is recommended as an additional fuse protection for the system.**

**Control MS-L...-LS**

The high water level is monitored by the rod float sensor. A separate switching point is stored in the parameter sets for the high water level. No additional float switch is required.

**Control MS-L...-C...-LS**

The high water level is monitored by the rod float switch. A separate switching point is set for the high water level. No additional float switch is required.

### 6.5.10 Collective fault signal connection (SSM)



#### DANGER

##### Danger of death due to electrical current!

The external electrical power supply is also present at the terminals when the main switch is switched off!

- Disconnect the external power supply before any work.
- Electrical work must be carried out by a qualified electrician.
- Observe local regulations.



#### NOTICE

##### Operational principle of the collective fault signal (SSM)

The relay of the collective fault signal falls of in case of a fault (SSM active). In this way, an outage of the mains voltage can also be observed!

The connection diagrams show the relays free of voltage.

#### Control MS-L1...

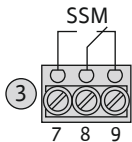

#### Control MS-L2...

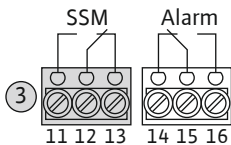

Fig. 14: Terminal strip sensors: SSM

### 6.5.11 Connection external alarm signal for high water alarm



#### DANGER

##### Danger of death due to electrical current!

The external electrical power supply is also present at the terminals when the main switch is switched off!

- Disconnect the external power supply before any work.
- Electrical work must be carried out by a qualified electrician.
- Observe local regulations.

#### Control MS-L2...

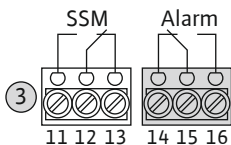

Fig. 15: Terminal strip sensors: external alarm signal for high water

A fault message is issued for all pumps (SSM) via a separate output:

- Contact type: potential-free changeover contact
- Contact load:
  - Minimum: 12 VDC, 10 mA
  - Maximum: 250 VAC, 1 A

Insert the connection cables laid by the customer through the threaded cable glands and secure. Connect the wires to the terminal strip according to the connection diagram.

Switchgear	Normally closed contact (NC)	Normally open contact (NO)
Control MS-L1 ...	Terminal 8/9	Terminal 7/8
Control MS-L2 ...	Terminal 12/13	Terminal 11/12

An external alarm signal (horn, flashing light, etc.) can be connected for the high water alarm:

- Contact type: potential-free changeover contact
- Contact load:
  - Minimum: 12 VDC, 10 mA
  - Maximum: 250 VAC, 1 A

Insert the connection cables laid by the customer through the threaded cable glands and secure. Connect the wires to the terminal strip according to the connection diagram.

Switchgear	Normally open contact (NO)	Normally closed contact (NC)
Control MS-L1...	–	–
Control MS-L2...	Terminal 15/16	Terminal 14/15

## 6.6 Functions

The switchgear is equipped with the following functions. All functions are switched off at the factory. The functions must be switched on as required.

	Control MS-L 1...	Control MS-L 1...-O	Control MS-L 1...-LS	Control MS-L 1...-C...-LS	Control MS-L 2...	Control MS-L 2...-O	Control MS-L 2...-LS
Internal buzzer	•	•	•	•	•	•	•
Pump kick	•	•	•	•	•	•	•
Service interval indicator	–	–	–	–	•	•	•
Monitoring operating parameters	–	–	–	–	–	–	•
Follow-up time	•	•	•	•	•	•	•
Adjustable switching points for pump ON and high water*	–	–	•	–	–	–	•

### Key

• = available , – = not available

\* A set of parameters is set at the factory. The switching points can be adjusted via further parameter sets, if necessary. Further information about the possible switching points can be found in the installation and operating instructions of the corresponding lifting unit.

#### 6.6.1 Internal buzzer



Fig. 16: DIP switch 1: internal buzzer

The internal buzzer can also issue audible warning messages in addition to the visual indicator. Switch the internal buzzer on/off via DIP 7 on DIP switch 1:

- “ON” position: Buzzer on
- “OFF” position: Buzzer off

#### 6.6.2 Pump kick



Fig. 17: DIP switch 1: Pump kick

To prevent prolonged standstill periods for the connected pumps, a periodic test run can be performed (pump kick function). A 2 s test run takes place after a standstill period of 24 h for the respective pump.

Switch the pump kick on/off via DIP 6 on DIP switch 1:

- “ON” position: Pump kick on
- “OFF” position: Pump kick off

#### 6.6.3 Service interval indicator

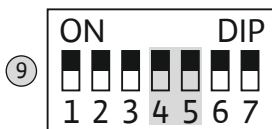

Fig. 18: DIP switch 2: Service interval indicator

A service interval indicator can be switched on to increase operational reliability. The time is recorded continuously when the mains voltage is switched on. After the interval has elapsed, a visual signal is emitted by means of the yellow LED on the front. **NOTICE! There is no audible signal and the collective fault signal is not activated!**

Switch the desired interval on and off via DIPs 4 and 5 on DIP switch 2:

- DIP 4 and 5 “OFF”: Service interval off
- DIP 4 “ON”: ¼ year service interval
- DIP 5 “ON”: ½ year service interval
- DIP 4 and 5 “ON”: 1 year service interval

Contact customer service to reset the counter.

#### 6.6.4 Monitoring operating parameters (Control MS-L2 ... -LS only)

The following operating parameters can be monitored on each pump to increase the operational reliability:

- Connections /h (default factory setting: 90/h)
- Connections /d (default factory setting: 90×24/d)
- Running time /h (default factory setting: 18 min/h)

If the **factory-set** parameters are exceeded, a visual signal is emitted via the yellow LED on the front. **NOTICE! There is no audible signal and the collective fault signal is not activated!**

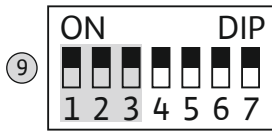

Fig. 19: DIP switch 2: Monitoring the operating parameters

6.6.5 Follow-up time

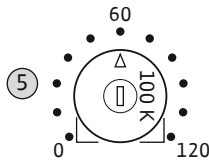

Fig. 20: Adjusting the follow-up time

6.6.6 Set switching points (only Control MS-L...-LS)

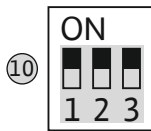

Fig. 21: DIP switch 3: Setting the switching points

Switch the desired monitoring devices on and off via DIPs 1 to 3 on DIP switch 2:

- DIP 1: Connections/h
- DIP 2: Connections/d
- DIP 3: Running time/h

Contact customer service to reset the counter.

The follow-up time defines the time between the level control device “OFF” signal and the pump being deactivated by the switchgear. Adjust the follow-up time continuously at the potentiometer.

Setting ranges

- Control MS-L1...: 0...30 s
- Control MS-L1...-C...-LS: 0 to 120 s
- Control MS-L2...: 0 to 120 s

The switching points for the lifting unit are set at the factory. The switching points can be adjusted to increase the usable volume. The switching points are stored in eight sets of parameters. The sets of parameters are set via DIP switch 3.

**NOTICE! Consult the sets of parameters in the installation and operating instructions for the respective lifting unit!**

DrainLift SANI CUT-S

The lifting unit DrainLift SANI CUT-S is equipped with a rod float switch. This float switch has a fixed switching point that cannot be changed. The DIP switch is thus dispensed with in the switchgear “Control MS-L1...-C...-LS”.

7 Operation



**DANGER**

**Danger of death due to electrical current!**

There is danger of death from open switchgear.

- Only operate the switchgear when closed.
- Electrical work on the internal components must be carried out by a qualified electrician.

7.1 Operating elements

The switchgear is operated via the following operating elements:





- Main switch
- Buttons on the side control panel
- LEDs on the front

7.1.1 Main switch

The standard version is switched on and off using a main switch. The main switch can be secured against unauthorised switching on and off using a lock!

7.1.2 Buttons













Function	Buttons		Description
	MS-L1...	MS-L2...	
Manual mode		 	Pressing the button switches the respective pump on independent of the level control. The pump operates as long as the button is held down. This function is intended for test mode.
Automatic mode			Press the button to switch on automatic mode. The pumps are switched on and off independent of the level control.

Function	Buttons		Description
	MS-L1...	MS-L2...	
Stop			Press the button to switch off automatic mode. The pumps are not controlled dependent on the level. The switchgear is in standby mode.
Buzzer off/reset			Press the button to switch the integrated buzzer off and deactivate the collective fault signal (SSM).  Press the button for more than 1 s to acknowledge a fault. This releases the control again.

### 7.1.3 LEDs







**Control MS-L2...:** Pump-dependent LEDs are displayed in two rows using the symbols:

- Top row: current status of pump 1
- Bottom row: current status of pump 2

Display	LED		LED colour	Description
	MS-L1...	MS-L2...		
Mains connection			Green	LED <b>lights up</b> : Mains voltage and control voltage are on.
Automatic mode			Green	LED <b>flashes</b> : Switchgear switched on – standby mode LED <b>lights up</b> : Automatic mode switched on LED <b>off</b> : Pump deactivated (only Control MS-L2...)
Pump operation			Green	LED <b>flashes</b> : Pump running during the set follow-up time. LED <b>lights up</b> : Pump is running.
Service interval/operating parameters	–		Yellow	LED <b>lights up</b> : Service interval has elapsed. LED <b>flashes</b> : Operating parameters exceeded.
High water alarm			Red	LED <b>lights up</b> : High water alarm activated
“Motor current monitoring” fault			Red	LED <b>flashes</b> : Switchgear is operated without any load. LED <b>lights up</b> : Set rated current exceeded
“Thermal motor monitoring” fault			Red	LED <b>lights up</b> : Temperature sensor in motor triggered

### 7.1.4 Key lock

Activate the key lock to prevent inadvertent or unauthorised activation of buttons:

Description	Buttons	
	MS-L1...	MS-L2...
Switch the key lock on and off by pressing the following buttons at the same time (for approx. 1 s): manual mode (pump 1), stop and automatic mode.  All LEDs light up for approx. 2 s by way of confirmation.	  	  

Observe the following points:

- If a button is pressed when the key lock is active, all LEDs light up for 2 sec.
- The buzzer can be switched off and the collective fault signal (SSM) deactivated when the key lock is active.
- Acknowledgement of error messages is **not** possible!

## 7.2 How it works

### Control MS-L1...

In automatic mode, the pump is switched on and off depending on the water level. Once the activation point has been reached, the pump switches on. The green LED lights up during operation. Once the deactivation point has been reached, the pump is switched off after the follow-up time has elapsed.

Once the high water level has been reached, the pump is switched on (forced switch-on). The high water LED displays an alarm signal. Additionally, the internal buzzer can emit an

audible alarm signal. Furthermore, the output for the collective fault signal (SSM) is activated.

The LEDs display an alarm signal when there is a fault. Additionally, the internal buzzer can emit an audible alarm signal. Furthermore, the output for the collective fault signal (SSM) is activated.

#### Control MS-L2...

In automatic mode, the pumps are switched on and off depending on the water level. Once the first activation point has been reached, pump 1 switches on. Once the second activation point has been reached, pump 2 switches on. The green LED for each pump lights up during operation. Once the deactivation point has been reached, the respective pump is switched off after the follow-up time has elapsed. To optimise pump running times, pump cycling is carried out every time the pump is switched off.

Once the high water level has been reached, both pumps are switched on (forced switch-on). The high water LED displays an alarm signal. Additionally, the internal buzzer can emit an audible alarm signal. Furthermore, the output for the collective fault signal (SSM) and the high water alarm (Alarm) is activated.

The LEDs display an alarm signal when there is a fault. Additionally, the internal buzzer can emit an audible alarm signal. Furthermore, the output for the collective fault signal (SSM) is activated.

#### 7.2.1 Motor current monitoring

The electronic motor current monitoring monitors the rated current of the connected pump. If the set rated current is exceeded, the pump is deactivated.

**NOTICE! Three-phase current motor: If the rated current falls below 300 mA for more than 1 s, the pump is also deactivated!**



Acknowledge the error message with the “Buzzer off/reset” button.

#### 7.2.2 Thermal motor monitoring

The thermal motor monitoring is self-acknowledging. After the motor winding has cooled down, the error is automatically reset. The LED goes off and the collective fault signal is deactivated!

#### 7.2.3 High water alarm

This high water alarm is self-acknowledging. After the water level drops, the error is automatically reset. The LED goes off and the collective fault signal and the external alarm signal (only Control MS-L2...) are deactivated!

#### 7.2.4 Collective fault signal

The relay of the collective fault signal falls off under the following conditions (SSM active):

- No mains voltage
- Main switch off
- Motor current monitoring fault
- Thermal motor monitoring fault
- High water

The relay of the collective fault signal does **not** fall off under the following conditions (SSM not active):

- Service interval signal
- Operating parameters signal
- Sensor fault signal (only Control MS-L ... -LS)

## 8 Commissioning

### 8.1 Operator responsibilities

- Provide installation and operating instructions at the switchgear or at a place specially reserved for it.
- Make the installation and operating instructions available in a language the personnel can understand.
- Make sure that the installation and operating instructions are read and understood by all personnel.
- The installation site of the switchgear is overflow-proof.
- The switchgear must be properly fused and earthed.
- The signal transmitter must be installed and set in accordance with the system documentation.
- Observe the minimum water submersion of the connected pumps.

- Safety devices (incl. emergency off) of the entire system are switched on and checked for trouble-free operation.
- The switchgear is suitable for use under the specified operating conditions.

## 8.2 Commissioning in explosive atmospheres

The switchgear may **not** be put into operation in potentially explosive atmospheres!



### DANGER

**Risk of explosion if the switchgear is installed in potentially explosive areas!**

The switchgear does not have its own explosion protection class and must always be installed outside of potentially explosive areas! The connection must be made by a qualified electrician.

## 8.3 Connection of signal transmitters within potentially explosive atmospheres



### DANGER

**Risk of explosion if signal transmitters are installed in potentially explosive areas!**

The switchgear does not have an intrinsically safe circuit for connecting the signal transmitters. The signal transmitters must always be installed outside of potentially explosive areas! The connection must be made by a qualified electrician.

## 8.4 Activating the device



### NOTICE

#### Integrated rotating field monitoring

The switchgear monitors the rotating field at the mains connection. There is an audible and visual error message if the mains connection has a counter-clockwise rotating field:

- Continuous tone via the integrated buzzer.
- All LEDs flash anticlockwise as running light.



### NOTICE

#### Operating mode after power failure

Following a power failure, the switchgear will automatically start up in the last operating mode set.

- ✓ Switchgear is closed.
  - ✓ Installation carried out correctly.
  - ✓ All signal transmitters and consumers are connected and installed.
  - ✓ Switching points set correctly.
  - ✓ Motor protection set.
  - ✓ Functions activated.
  - ✓ Follow-up time set.
1. Turn the main switch to the "1/ON" position.  
**NOTICE! Switchgear without main switch: Establish power supply by means of mains isolator!**
  2. Switchgear starts. All LEDs light up for 2 s.
    - ▶ The switchgear is ready for operation.
    - ▶ LED "on" lights up.
    - ▶ LED "auto" shows the current operating mode:
      - LED **flashes**: Standby mode
      - LED **lights up**: Automatic mode. In order to switch to standby mode, press the "stop" button.



## 8.5 Installing the rechargeable battery



### DANGER

#### Risk of fatal injury due to electrical current!

There is a risk of fatal injury when performing work on the open switchgear! The components carry current!

- Have work carried out by a qualified electrician.
- Avoid contact with earthed metal parts (pipes, frames etc.).



### NOTICE

#### Mains-independent alarm

The alarm sounds as soon as the rechargeable battery is inserted. The alarm can only be switched off by removing the rechargeable battery again or by connecting the power supply.

By inserting a rechargeable battery, a mains-independent alarm signal can be issued in the case of a power failure. An audible, constant tone is emitted as an alarm. Observe the following points:

- Rechargeable battery type: E-Block, 9 V, Ni-MH
- In order to ensure trouble-free operation, charge the rechargeable battery prior to insertion or charge it for 24 h in the switchgear.
- The capacity of the rechargeable battery will fall if the ambient temperature drops. The alarm running time is reduced.

- ✓ Power supply connected.
- ✓ Main switch in the "0/OFF" position!

**NOTICE! Switchgear without main switch: Disconnect power supply with mains isolator!**

1. Insert the rechargeable battery into the designated holder, see "Overview of components".

**WARNING! Do not insert any batteries! There is a risk of explosion!**

**CAUTION! Observe the correct polarity!**

2. Plug in the connection cable.
  - ⇒ Alarm sounds!
3. Turn the main switch to the "1/ON" position.
 

**NOTICE! Switchgear without main switch: Establish power supply by means of mains isolator!**

  - ⇒ Alarm off!
  - ▶ Rechargeable battery installed.

## 8.6 Check the direction of rotation of the connected pumps



### NOTICE

#### Power supply and pump connection rotating field

The rotating field is routed from the mains connection directly to the pump connection.

- Check the required rotating field of the pumps to be connected (clockwise or counter-clockwise).
- Observe the installation and operating instructions of the pumps.

Perform a test run to check the direction of rotation of the pumps. **CAUTION! Material damage! Perform the test run under the prescribed operating conditions.**

- ✓ Switchgear closed.
  - ✓ Pumps activated (only Control MS-L2...)
1. Press button for "Manual mode". The pump runs until the button is released.
  2. Check the direction of rotation of the pump.
    - ⇒ **Incorrect direction of rotation:** Exchange two phases on the pump connection.

- Direction of rotation checked and corrected as necessary.
- 8.7 Start automatic mode**
- ✓ Switchgear closed.
  - ✓ Main switch switched on.
  - ✓ Direction of rotation correct.
  - ✓ LED “on” lights up.
  - ✓ LED “auto” flashes.
1. Press the “auto” button.
    - ⇒ LED “auto” lights up
    - Automatic mode switched on.
    - The “Pump operation” LED shows the current status of the pump.
- 8.8 During operation**
- Make sure the following points are observed during operation:
- Keep the switchgear closed and secure it against unauthorised opening.
  - Switchgear attached in an overflow-proof manner (protection class IP54).
  - Not exposed to direct sunlight.
  - Ambient temperature: -30 ... +60 °C.
- The “Pump operation” LED shows the current status of the pump:
- LED **lights up**: Pump is running.
  - LED **flashes**: Pump running during the set follow-up time.
  - LED **off**: Pump off.
- 9 Shut-down**
- 9.1 Personnel qualifications**
- Electrical work: qualified electrician  
Person with appropriate technical training, knowledge and experience who can identify and prevent electrical hazards.
  - Installation/dismantling work: qualified electrician  
Knowledge regarding tools and fixation material for various structures
- 9.2 Operator responsibilities**
- Observe locally applicable accident prevention and safety regulations of trade associations.
  - Make sure that the personnel has had the corresponding training for the specified work.
  - Train the personnel on how the system operates.
  - When working in enclosed spaces, a second person must be present for safety reasons.
  - Ensure enclosed spaces have sufficient ventilation.
  - Take immediate countermeasures if there is a build-up of toxic or suffocating gases!
- 9.3 Shut-down**
- To decommission the pumps, switch off the pumps and switchgear at the main switch. The switchgear is ready for operation at any time. Adhere to the following points during the standstill period:
- Ambient temperature: -30 ... +60 °C
  - Max. humidity: 50 %, non-condensing
  - ✓ System is prepared for decommissioning, e.g. inlet in pump chamber closed.
1. Press the “stop” button.
    - ⇒ The “Pump operation” LED goes out.
    - ⇒ LED “auto” flashes.
  2. Turn main switch to the “0/OFF” position.
    - ⇒ The “on” LED goes out.
    - ⇒ The “auto” LED goes out.
  3. Secure the main switch against being activated by unauthorised persons (e.g. lock main switch)
    - Switchgear switched off.

## 9.4 Removal



### DANGER

#### Risk of fatal injury due to electrical current!

Improper conduct when carrying out electrical work can lead to death due to electric shock!

- Electrical work must be carried out by a qualified electrician!
- Observe local regulations!

- ✓ Decommissioning performed.
  - ✓ Mains connection is switched so that it is voltage-free and safeguarded against being activated by unauthorised persons.
  - ✓ The power connection for fault and run signals is switched so that it is voltage-free and safeguarded against being activated by unauthorised persons.
1. Open the switchgear.
  2. Disconnect all connection cables and pull them out through the threaded cable connection.
  3. Close off the ends of the connection cables watertight.
  4. Seal threaded cable connections watertight.
  5. Support the switchgear (e.g. get a second person to help).
  6. Loosen the switchgear fastening screws and remove the switchgear from the structure.
    - ▶ Switchgear removed. Observe the following for storage!

## 10 Maintenance



### DANGER

#### Risk of fatal injury due to electrical current!

Improper conduct when carrying out electrical work can lead to death due to electric shock!

- Electrical work must be carried out by a qualified electrician!
- Observe local regulations!



### NOTICE

#### Unauthorised work or structural changes are prohibited!

Only maintenance and repair work described in this manual may be carried out. All other works and any alterations to the construction may only be carried out by the manufacturer.

### 10.1 Maintenance intervals

#### Regular

- Clean switchgear.

#### Annually

- Check electro-mechanical components for wear.

#### After 10 years

- General overhaul

### 10.2 Maintenance tasks

#### Cleaning switchgear

- ✓ Switch off switchgear.

1. Clean switchgear with a damp cotton cloth.

**Do not use any aggressive or scouring cleaners or fluids!**

#### Check electro-mechanical components for wear

- Have electro-mechanical components checked for wear by an electrician.
- If wear is ascertained, have the affected components replaced by an electrician or by the Wilo Customer Service.

## General overhaul

During a general overhaul, all of the components, wiring and the housing are checked for wear. Defective or worn components are replaced.

## 11 Faults, causes and remedies



### DANGER

#### Risk of fatal injury due to electrical current!

Improper conduct when carrying out electrical work can lead to death due to electric shock!

- Electrical work must be carried out by a qualified electrician!
- Observe local regulations!

### 11.1 Operator responsibilities

- Observe locally applicable accident prevention and safety regulations of trade associations.
- Make sure that the personnel has had the corresponding training for the specified work.
- Train the personnel on how the system operates.
- When working in enclosed spaces, a second person must be present for safety reasons.
- Ensure enclosed spaces have sufficient ventilation.
- Take immediate countermeasures if there is a build-up of toxic or suffocating gases!

### 11.2 Fault indication

The LEDs indicate possible faults. Have the system checked according to the displayed fault and have defective components replaced. Faults are displayed as follows:







- LED lights up or flashes.
- The collective fault signal is activated.
- If the internal buzzer is activated, there is an audible alarm signal.

### 11.3 Fault acknowledgement

- Press the “Buzzer off/reset” button to deactivate the alarm and the collective fault signal.
- Press the “Buzzer off/reset” button for at least 1 s to acknowledge a fault.









**NOTICE! The fault can only be acknowledged once the error has been remedied!**

### 11.4 Error messages

Symbol	Signalling	Cause	Troubleshooting
	LED <b>lights up</b> .	Service interval has elapsed.	Carry out maintenance. Have customer service reset the counter.
	LED <b>flashes</b> .	Operating parameters exceeded.	Check the system's settings. Have customer service reset the counter.
	LED <b>lights up</b> .	High water alarm active	Check pump/system operating conditions and level settings.
	LED <b>flashes</b> .	Switchgear is operated without any load.	Check mains connection of the switchgear and pump connection.
	LED <b>lights up</b> .	Set rated current exceeded	Check and, if necessary, correct the setting of DIP switch 1.
	LED <b>lights up</b> .	Temperature sensor in motor triggered	Check connection, the converter bridge may be missing. Check the operating conditions of the pump.
	All LEDs light up for 2 s.	Key lock active	Deactivate key lock.
	All LEDs light up from right to left.	Incorrect phase sequence at mains connection	Swap over 2 phases at the mains connection of the switchgear.
	All LEDs flash at the same time.	Sensor fault	Check connection. Contact customer service to have the faulty sensor replaced.

### 11.5 Fault memory

The last fault is stored retentively in the fault memory. The corresponding LED lights up when the fault is retrieved.

Function	Buttons		Description
	MS-L1...	MS-L2...	
Open the fault memory.	 	 	Pressing the Stop and automatic mode buttons at the same time.
Delete the fault memory.	 	 	Pressing the Stop and manual mode buttons for longer (approx. 1 s) at the same time (pump 1).

### 11.6 Further steps for troubleshooting

If the points listed here do not rectify the fault, please contact customer service. Costs may be incurred if other services are used. For more details, please contact customer service.

## 12 Disposal

### 12.1 Rechargeable battery

Do not dispose of rechargeable batteries in domestic waste and remove them before product disposal. End consumers are legally obliged to return all used rechargeable batteries. For this purpose, you can return used rechargeable batteries free of charge at municipal collection points or specialist retailers.



#### NOTICE

##### Disposal in domestic waste is prohibited!

Affected rechargeable batteries are marked with this symbol. The identifier for the heavy metal they contain is displayed beneath the graphic:

- **Hg** (mercury)
- **Pb** (lead)
- **Cd** (cadmium)

### 12.2 Information on the collection of used electrical and electronic products

Proper disposal and appropriate recycling of this product prevents damage to the environment and danger to your personal health.



#### NOTICE

##### Disposal in domestic waste is prohibited!

In the European Union this symbol may be included on the product, the packaging or the accompanying documentation. It means that the electrical and electronic products in question must not be disposed of along with domestic waste.

To ensure proper handling, recycling and disposal of the used products in question, please note the following points:

- Hand over these products at designated, certified collection points only.
- Observe the locally applicable regulations!

Please consult your local municipality, the nearest waste disposal site, or the dealer who sold the product to you for information on proper disposal. See [www.wilo-recycling.com](http://www.wilo-recycling.com) for more information about recycling.

## 13 Appendix

### 13.1 System impedances



#### NOTICE

##### Maximum switching frequency per hour

The connected motor determines the maximum switching frequency per hour.

- Note the technical data of the connected motor.
- Do not exceed the maximum switching frequency of the motor.



## NOTICE

- Depending on the system impedance and the maximum connections/hour of the connected consumers, voltage fluctuations and/or drops may occur.
- When using shielded cables, attach the shielding to the earth rail on one side of the control device.
- Always have connection carried out by a qualified electrician.
- Observe the installation and operating instructions for the connected pumps and signal transmitters.

### 1~230 V, 2-pole, direct starting

Power in kW	System impedance in ohm	Connections/h
1.5	0.4180	6
1.5	0.3020	24
1.5	0.2720	30
2.2	0.2790	6
2.2	0.1650	24
2.2	0.1480	30

### 3~400 V, 2-pole, direct starting

Power in kW	System impedance in ohm	Connections/h
2.2	0.2788	6
2.2	0.2126	24
2.2	0.1915	30
3.0	0.2000	6
3.0	0.1292	24
3.0	0.1164	30
4.0	0.1559	6
4.0	0.0889	24
4.0	0.0801	30

### 3~400 V, 4-pole, direct starting

Power in kW	System impedance in ohm	Connections/h
2.2	0.2330	24
2.2	0.2100	30
3.0	0.2090	6
3.0	0.1380	24
3.0	0.1240	30
4.0	0.1480	6
4.0	0.0830	24
4.0	0.0740	30



# wilo



Local contact at  
[www.wilo.com/contact](http://www.wilo.com/contact)

Pioneering for You

WILO SE  
Wilopark 1  
44263 Dortmund  
Germany  
T +49 (0)231 4102-0  
T +49 (0)231 4102-7363  
[wilo@wilo.com](mailto:wilo@wilo.com)  
[www.wilo.com](http://www.wilo.com)