

wilo

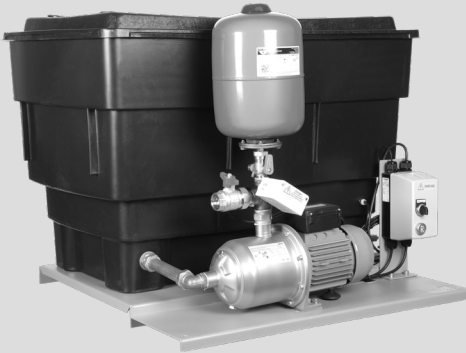

CAT 5 MHI(E)

EN Installation and operating instructions

2819142	CAT5 1MHI202/PS-EM	29992800	CAT5 1MHI202/EC-EM-2
2819143	CAT5 1MHI203/PS-EM	29992801	CAT5 1MHI203/EC-EM-2
2819144	CAT5 1MHI204/PS-EM	29992802	CAT5 1MHI204/EC-EM-2
2819145	CAT5 1MHI205/PS-EM	29992803	CAT5 1MHI205/EC-EM-2
2819146	CAT5 1MHI206/PS-EM	29992804	CAT5 1MHI206/EC-EM-2
2819147	CAT5 1MHI402/PS-EM	29992805	CAT5 1MHI402/EC-EM-2
2819148	CAT5 1MHI403/PS-EM	29992806	CAT5 1MHI403/EC-EM-2
2819149	CAT5 1MHI404/PS-EM	29992807	CAT5 1MHI404/EC-EM-2
2819150	CAT5 1MHI405/PS-EM	29992808	CAT5 1MHI405/EC-EM-2
2819151	CAT5 1MHI406/PS-EM	29992809	CAT5 1MHI406/EC-EM-2
2819152	CAT5 1MHIE205/DM		
2819153	CAT5 1MHIE205/EM		
2819280	CAT5 1MHIE803/DM		
2819336	CAT5 1MHIE403/EM		
29991772	CAT5 1MHIE 406/DM		

Contents

1) General	
2) Safety Instructions	
2.1 Symbols and Signals	3
2.2 Modification and Spares	3
3) Transport and Storage	3
4) Description and Operation	
4.1 MHI PS-EM (Single Phase Fixed Speed)	3
4.1.1 Operation Modes	3
4.1.2 Operating Features	3
4.2 MHIE DM (Three Phase Variable Speed)	4
4.2.1 Operation Modes	4
4.2.2 Operating Features	4
4.3 MHI EC-EM (Single Phase Variable Speed)	4
4.3.1 Operation Modes	4
4.3.2 Operating Features	4
4.4 MHIE EM (Single Phase Variable Speed)	4
4.4.1 Operation Modes	4
4.4.2 Operating Features	4
5) Installation	
5.1 Hydraulic Connections	4
5.2 Electrical Connections	4
6) Commissioning	
6.1 Commissioning	5
6.2 Maintenance	5
7) Warranty	5
8) Figures	
Fig 1 MHI PS-EM Electrical Connections	6
Fig 2 MHIE DM Electrical Connections	6
Fig 3 MHI EC-EM Electrical Connections	7
Fig 4 MHIE EM Electrical Connections	7
Fig 5 System General Arrangement	8
Fig 6 MHI PS-EM General Arrangement	8
Fig 7 MHIE DM General Arrangement	9
Fig 8 MHIE EM Controls	9
Fig 9 MHI EC-EM General Arrangement	10
9) Tables	
Table 1 EC-EM Drive User Interface	10
Table 2 EC-EM Settings Menu	11
Table 3 Drive Fault Codes	12
Table 4 Spare Parts	13

1 General

The CAT 5 booster set is a pressure boosting system designed for raising the pressure of water for wash down requirements. Using a single pump fixed or variable speed booster, 115 litre actual capacity tank with category 5 backflow prevention via an AB airgap.



ATTENTION! Installation and commissioning by qualified personnel only!



NOTE – An onsite audit must be completed once installed to ensure there are no contributing factors that may compromise the air gap (ie. foaming, splashing)

2 Safety

Any works carried out on CAT 5 booster sets must be completed by a qualified person. Failure to comply to any of the information in this manual may cause potential hazards to people and the environment and may void the warranty.

Operators must be fully aware of all functions of the booster set and any risks associated. For more information on training please contact Wilo Ph: 01283 523 000



WARNING! Local regulations must be complied to when installing and maintaining the booster set

2.1 Symbols and Signals



DANGER! Extremely dangerous situation. Non-observance could cause death or serious injuries.



WARNING! The user may suffer from injuries (serious). The mention of warning involves that personal (serious) injuries may happen when precautions are not observed.



ATTENTION! Damage could be caused to the pump or installation. The mention of attention is used to indicate that by ignoring the relevant safety instructions, damage could be caused to the pump or its operation.



NOTE – Useful remark for product handling. Any possible difficulty is mentioned.

2.2 Modification and Spare Parts

Modifications to the booster are prohibited and will invalidate the warranty. Wilo Approved spares must be used at all times. For information on spares see Table 4 of this manual

3 Transport and Storage

CAT 5 booster must always be transported by pallet and moved with appropriate lifting equipment. Booster must be stored in a dry environment between –25 °C to +55 °C.

NOTE – If stored for future installation the film wrapping must not be removed and must be stored in a dry environment



4 Description and Operation

4.1 MHI PS-EM (Single Phase Fixed Speed)

4.1.1 Operating Mode

CAT 5 PS-EM is a fixed speed booster set which is controlled with a Hand Off Auto (HOA) box via a pressure switch. When the switch is turned to Hand Mode the set will run at full speed constantly and will not turn off. When the switch is turned to Auto Mode the set will run until the pressure set on the pressure switch has been reached. Once the pressure has been achieved the set will run until the programmable timer times out

4.1.2 Operating Features

- Programmable pressure switch – Sets the pressure at which the timer starts via dials on the front of the switch (Fig 6)
- Programmable timer – Sets the length of time the booster will run once the set pressure has been achieved. Programmable in the HOA box (Fig 6)
- Low water cut out switch – Turns the booster off instantly once the water level drops below a set level to stop air from entering the pump (Fig 1)
- Volt Free Contacts (VFC) – Normally open and normally closed contacts signal if the pump has tripped under high current (Fig 1)

NOTE – Programmable timer is inside the HOA box and is factory set at 120 seconds to reduce start/stop frequency of the set.



4.2 MHIE DM (Three Phase Variable Speed)

4.2.1 Operating Mode

CAT 5 DM is a variable speed booster set which is controlled via an integrated motor mounted drive and pressure transducer. Once the pressure is set on the drive the speed of the pump will ramp up and down according to the demand of the system (see pump manual for the setting of the system pressure)

NOTE – No flow cut off time can be changed in the drive via menu 5.2.7.0 and is factory set at 30 seconds

4.2.2 Operating Features

- 0–20mA pressure transducer monitors system pressure
- SBM Volt Free Contact (VFC) – Can be configured to switch on power up or run (see menu 4.7.6.0)
- SSM Volt Free Contact (VFC) – Switches when pump goes into fault conditions
- Low water cut out switch – Turns the booster off instantly once the water level drops below a set level to stop air from entering the pump

4.3 MHI EC–EM (Single Phase Variable Speed)

4.3.1 Operating Mode

CAT 5 EC–EM is a variable speed booster set which is controlled via a water cooled inverter. The pressure is set in the drive by holding down the menu button (Table 1) and cycling through the drive settings by pressing the 'Enter' button and changing the settings with the up and down arrows. For full programmable settings see Table 2. Once the pressure is set on the drive press the 'Automatic Mode' button and the speed of the pump will ramp up and down according to the demand of the system.

To run the pumps at a constant 50Hz press and hold the 'Manual Mode' button

4.3.2 Operating Features

- Low water cut out switch – Turns the booster off instantly once the water level drops below a set level to stop air from entering the pump
- Programmable electronic menu with alarm log and run timer (Table 2)

4.4 MHIE–EM (Single Phase Variable Speed)

4.4.1 Operating Mode

MHIE–EM is a variable speed booster set which is controlled via an integrated motor mounted drive and pressure transducer. System pressure is set via the variable speed dial on the side of the motor (Fig8). System pressure is approximately 1 bar for every 10% on the dial. Set the system pressure by starting at 0% on the dial and slowly raising until required setpoint is reached.

ATTENTION! Test pressure setpoint, by isolating the system via isolation valve to reduce the risk of over pressure in the system

4.4.2 Operating Features

- Programmable electronic menu with alarm log and run timer (Table 2)
- Pump fail volt free contact 230V 1A (Fig4)

5 Installation

5.1 Hydraulic Connections (Fig5)

The mains water is connected directly onto the ½" male BSP thread equilibrium ball valve. The booster discharge is connected directly onto the isolation valve which has a 1" female BSP thread. All CAT 5 sets must be fitted with the supplied 8 litre diaphragm pressure vessel onto the vessel valve provided next to the isolation valve. Once the tank is filled the pump must be properly vented before use.

ATTENTION! Connections must be made according to local water authority regulations

5.2 Electrical Connections (Fig1–4)

Please use the correct wiring diagram provided with the booster for connection of mains voltage. Pay close attention to the terminals used and that the correct voltage is applied. Failure to do so may cause damage to pump or drives and will void the warranty.

DANGER! The electrical connections and testing must be carried out by a qualified electrician and in accordance with locally applicable standard specifications.



6 Commissioning

6.1 Commissioning

It is recommended that the first installation is commissioned by Wilo customer service. Contact us on service@wilo.com or Ph: 012835230000

Before switching on for the first time check the customers wiring is compliant with local regulations and is fit for purpose.

Check the pipe connections are stress free

Fill the storage tank and visually check for leaks

Close discharge valve and turn power on

Run pump against closed valve until pump switches off. This may require the adjustment of the pressure switch

Open system valve partially and allow unit to fill the system and switch off.

Ensure storage tank fill is adequate for the system. Do not allow pump to run dry, this may cause damage to the mechanical seal and other components.

Once system is filled fully open the system valve.

7 Warranty

WILO reserve the right to inspect an installation to verify that the equipment has been installed in accordance with the written instructions. The full warranty document is downloadable at www.wilo.com/gb/en/downloads. Click on local information then downloads. Before requesting a site visit, the following information must be available to the service team:

- Article number of the equipment
- A purchase order to cover the work in the event that no manufacturing defect is found.
- A site contact name and number
- A FULL description of the alleged fault



DANGER! Risk of fatal injury! Tighten all connection terminals prior to commissioning!

6.2 Maintenance

To ensure maximum reliability in operation we recommend that the expansion vessel is checked at least annually. This may require more frequent checks if the unit is subject to higher frequencies of use.

Checks should be made on condition of stored water tank and must be debris free.

Checks should be made on switching frequencies and operation.

The general safety instructions must be observed when carrying out any remedial work. Please follow the Installation and Operation manual for pump and control *unit*.



ATTENTION! Any maintenance must be completed by a trained and competent person. Any damage to the booster could void warranty if this is not adhered to

8) Figures

Fig. 1 - MHI PS-EM Electrical Connections

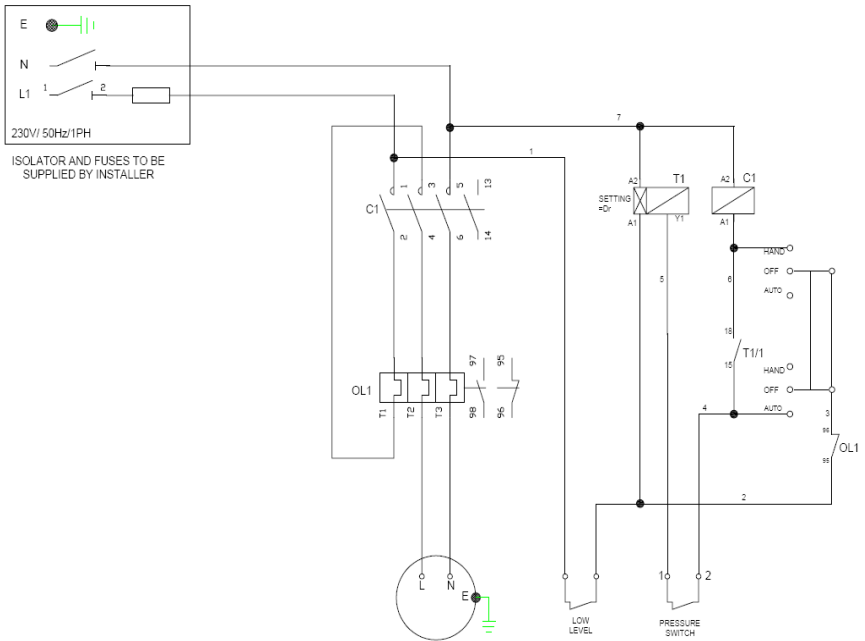

Fig. 2 - MHIE-DM Electrical Connections

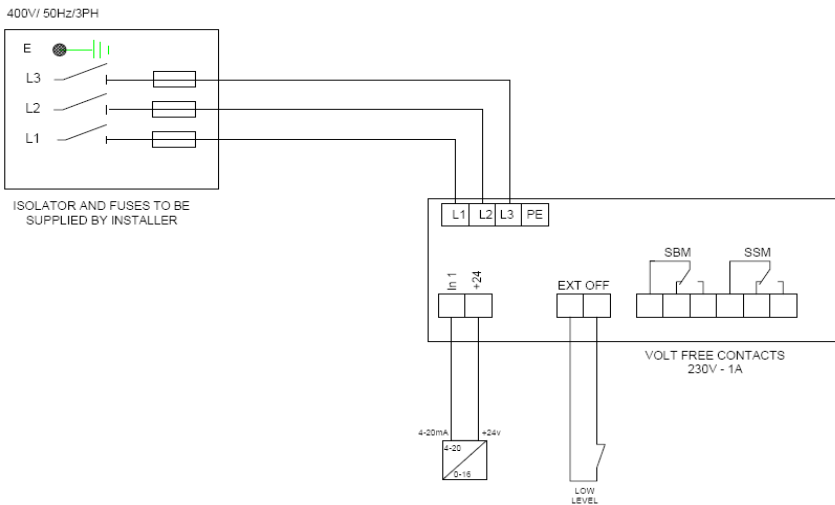

Fig. 3 - MHI EC-EM

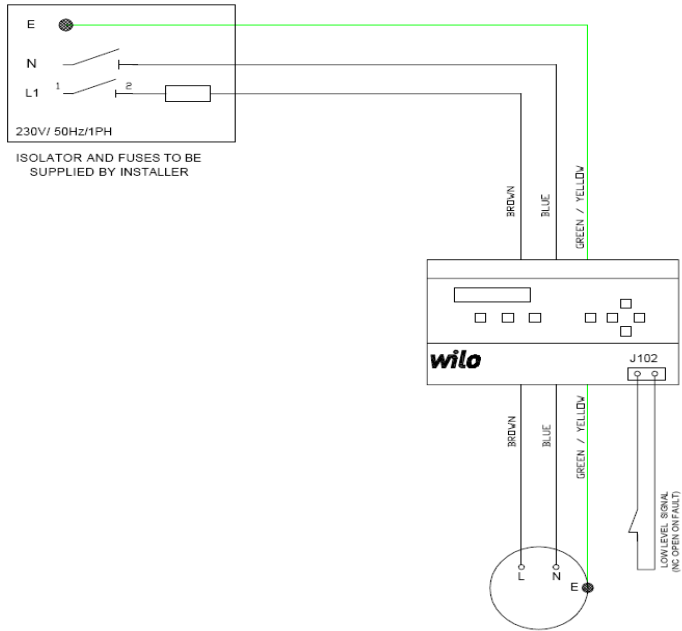

Fig. 4 MHIE EM Electrical Connections

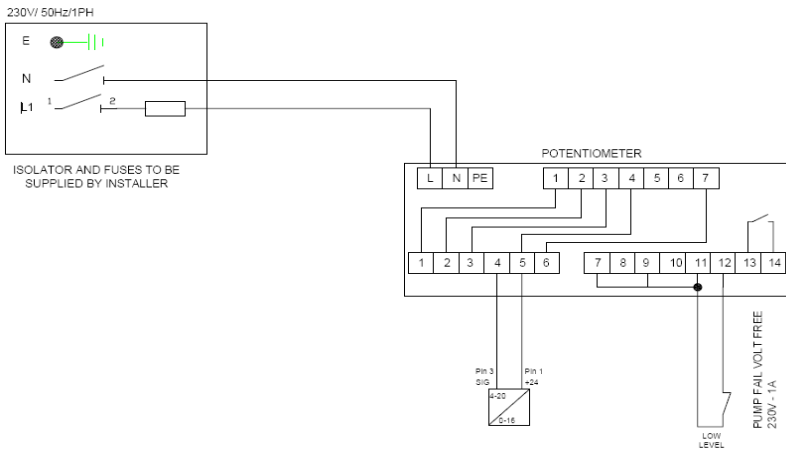

Fig. 5 General Arrangement (Hydraulic)

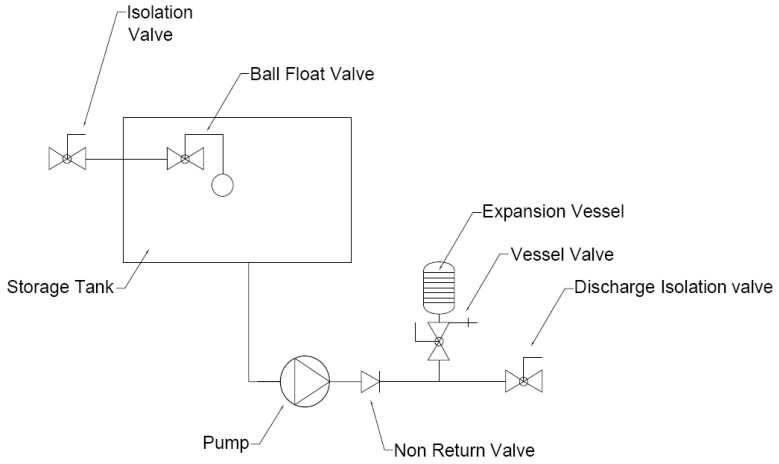

Fig. 6 PS-EM Layout

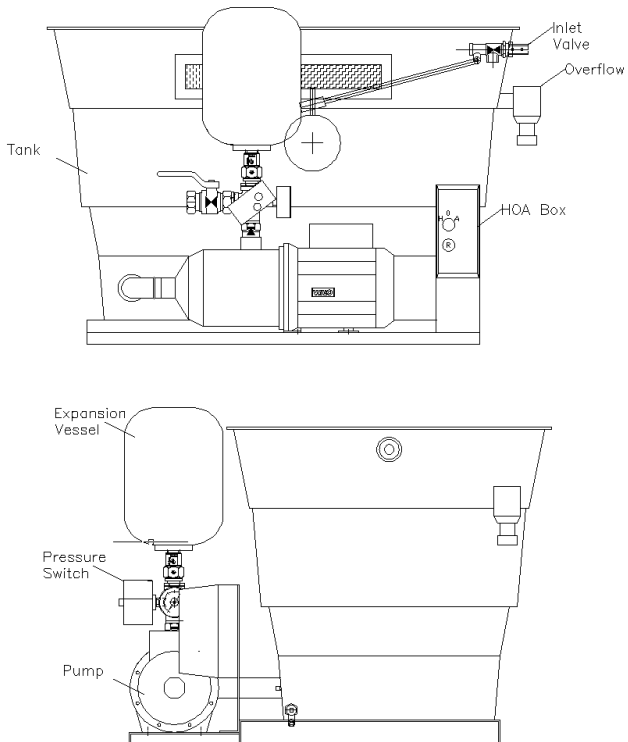

Fig. 7 MHIE-EM/DM Layout

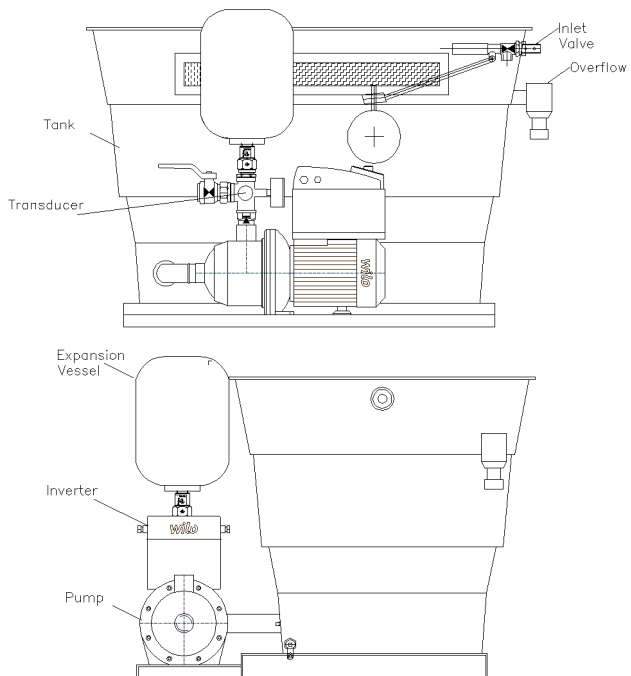

Fig. 8 MHIE-EM Controls

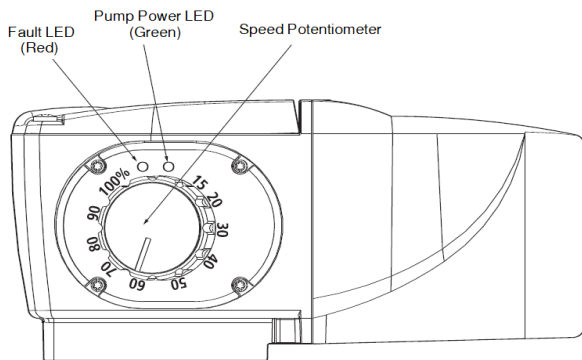

Fig. 9 MHI EC-EM Layout

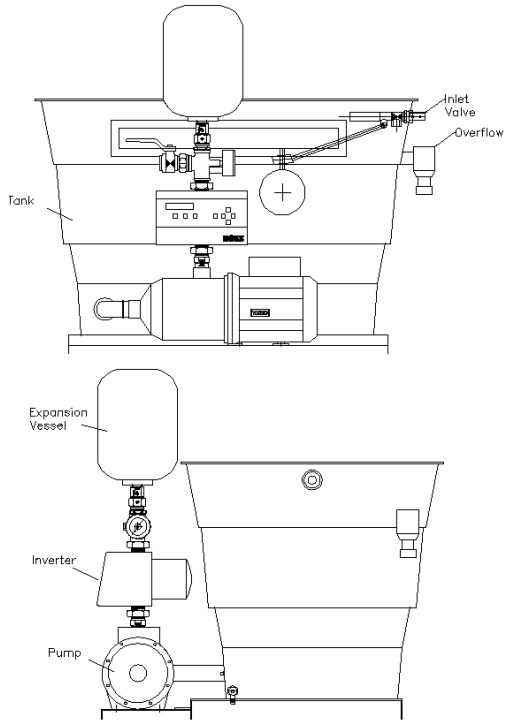
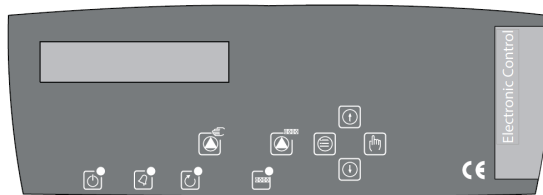

Table 1 Driver User Interface (EC-EM)











	Manual Mode		Inverter On	(Green LED)
	Automatic Mode		Alarm	(Red LED)
	Menu		Pump Running	(Yellow LED)
	Enter		Pump in Automatic Mode	(Green LED)

Table 2 Settings Menu (EC-EM)

MENU	SETTINGS	FACTORY	UNIT
Language	Language select	English	
I max	Set the maximum current rating of the pumps	*	Amps
Rotation Sense	Change the rotation of the motors	Clockwise	
Min Speed	Minimum running speed of the motor	15	Hz
Dry Run Prot	Turn on or off the dry running protection	Yes	
Pressure Setting	System pressure that you want the booster to achieve	**	Bar
Start Delta	Difference in pressure before the pumps start	0.3	Bar
Time Before Stop	Time the pumps will run once the pressure has been reached at no flow	15	Sec
MENU	HISTORIC		
Running Time	Total pump running hours		Hrs
Pump Cycles	Total number of pump cycles (one cycle = one run and stop)		
Power On	Number of times the drive has been powered on		
Max Pressure	Maximum pressure of the installation		Bar
Short Circuit	Total number of short circuit alarms		
Over Current	Total number over current alarms		
Over Temp.	Total number of over temperature alarms		
Dry Run	Total number of dry run alarms		

*Dependant on motor size

** Dependant on booster type (see test sheet)

Table 3 Drive Fault Codes

ERROR CODE	BOOSTER BEHAVIOUR	TROUBLESHOOT
E011 DRY RUN	The controller starts the pump every 30 minutes over 24 hours. If dry running remains, it switches off the pump.	Check the hydraulic supply. If a set point pressure higher than the pressure the pump can deliver is programmed, the controller will consider it as dry running.
E021 OVERLOAD	After the alarm detection the controller will try 4 times to start the pump. After these 4 trials the pump is switched off. Check the state of the fuses..	Check that the rotor is not locked. Check the input data in the controller
E025 DISCONNECT MOTOR	Motor will not start.	Check the motor winding. Check the supply cables. Check that the I _{max} is not set to off in the menu (Table 2)
E040 P SENSOR DEFFECT	The controller stops.	Contact the technical service department.
E031 OVER T°	If the temperature is too high, the controller will stop the motor from running.	Check that the water temperature does not exceed 40°C. Check that the ambient temperature does not exceed 50°C.
E023 SHT CIRCUIT	After the alarm detection the controller will try 4 times to start the pump. After these 4 trials the pump is switched off.	Check the motor connections and windings. If the problem remains contact the manufacturer.
E071 EEPROM	If the controller detects a defect on its internal memory this error will be displayed.	Contact the technical service department.
E005 HIGH VOLTAGE	If the controller detects an overvoltage, it stops over some seconds and then starts again.	Check the controller supply voltage.
E004 LOW VOLTAGE	If the controller detects an under voltage, it stops the pumps.	Check the controller supply voltage.
[WHITE SCREEN]	No function and nothing on the screen.	Check the controller supply voltage and circuit breakers in (Fig 1). Check the 20A fuses



EC - Declaration of conformity

Herewith, we declare that **CAT 5MHI-E** of the series

CAT 5MHI... PS/EM

CAT 5MHI... EC2/EM

CAT 5MHIE... DM

CAT 5MHIE... EM/DM

(The serial number is marked on the product site plant)
in its delivered state complies with the following relevant provisions:

EC-Machinery Directive

2006 / 42 / EC

Low Voltage Directive

2014 / 35 / EU

Electromagnetic Compatibility Directive

2014 / 30 / EU

WEEE Directive

2012 / 19 / EU

ROHS Directive

2015 / 863 / EU

As well as following harmonized standards

EN 809:1998 +A1:2009

EN60204-1 +A1 2009

EN61000-6-3:2007 +A1:2011

EN61000-6-2:2005

If the above mentioned series are technically modified without our approval, this declaration shall no longer be applicable

Authorized representative for the completion of the technical documentation:

Lee Tebbatt
Managing Director

2nd March 2020

WILO UK
Centrum 100
Second Avenue
Burton-Upon-Trent
DE14 2WJ

