

Wilo-NX

GB Installation and operating instructions

中 安装及操作维护说明书

CONTENTS

1.	General	2
1.1	Uses	2
1.2	Product data	2
1.2.1	Rating plate	2
1.2.2	Connection and electrical data	2
2.	Safety	3
2.1	Danger symbols used in these operating instructions.....	3
2.2	Staff training	3
2.3	Risks incurred by failure to comply with the safety precautions	3
2.4	Safety precautions for the operator.....	3
2.5	Safety information for inspection and assembly	3
2.6	Unauthorized modification and manufacture of spare parts	3
2.7	Unauthorized operating methods	3
3.	Transport and storage	4
3.1	Transport	4
3.1.1	General recommendations	4
3.1.2	Fitting the carrying cables	4
3.2	Storage.....	4
4.	Product and accessory description	4
4.1	Pump description	4
4.2	Products delivered	4
4.3	Accessories	4
4.4	Permissible forces and moments at the pump flanges	5
4.5	Expected noise values as guidelines	6
5.	Assembly/installation	6
5.1	Preparations	6
5.1.1	Unpacking and inspection	6
5.1.2	Site	6
5.1.3	Foundation.....	7
5.2	Installation.....	7
5.2.1	Alignment of pump / motor	8
5.3	Connecting the pipes	8
5.4	Final inspection.....	9
5.5	Electrical connection.....	9
6.	Operation.....	10
6.1	Initial start-up	10
6.1.1	Switching on.....	10
6.1.2	Switching off	10
6.2	Operation	10
6.3	Stop pump	11
7.	Maintenance.....	11
7.1	General information	11
7.2	Routine maintenance	11
7.2.1	Bearing brackets with rolling bearings	12
7.2.2	Shaft seals	12
7.3	Disassemble and assemble	12
8.	Problems, Caused and Solution	13
9.	Spare parts	15
9.1	Recommended stocking of spare parts for two-year continuous operation.....	15
9.1.1	NX pump	15
9.1.2	NX-A pump , NX-B pump and NX-C pump	15
9.2	Standard pump NX, modes with mechanical seal	16
9.2.1	NX pump (Fig.11)	16
9.2.2	NX-A pump (Fig.12)	16
9.2.3	NX-B pump and NX-C pump (Fig.13)	16
9.3	Spare-parts list	17
9.3.1	NX pump	17
9.3.2	NX-A pump , NX-B pump and NX-C pump	18

1. General

Assembly and installation should only be carried out by qualified personnel.

1.1 Uses

Pumps of the Wilo-NX series are used to transport Clean water, sea water, light oils or process fluids, similar to water, slightly contaminated water or fluids without solid matter and not easy crystallization.

- Sea water desalination,
- Pure water treatment
- General industry

1.2 Product data

1.2.1 Rating plate

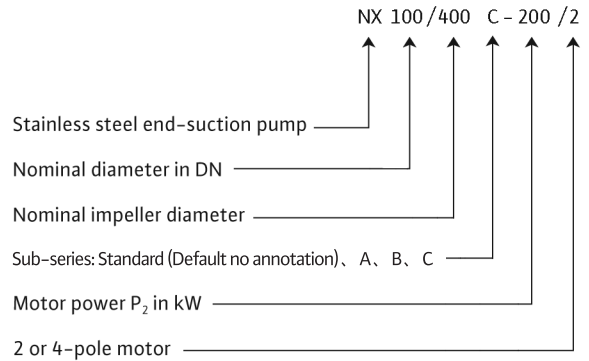

1.2.2 Connection and electrical data

No. of Revolutions:	2900, 1450 1/min	
Pressure support DN:	32~300	
Permissible temperature, min./max.	- 20°C to + 120°C with mechanical seal - 30°C to + 130°C with mechanical seal (only for NX-B/NX-C)	
Max.permissible ambient temperature	40°C	
Max. permissible working pressure:	16bar: only for NX 25bar: only for NX/NX-A/NX-B 30bar: only for NX-C	● ○ ○
Insulation class	F	
System of protection	IP55	
Motor protection	Passive thermal control (PTC)	
Pipe joints	Flange PN16(PN25)(PN40)acc.to DIN 2533/ISO 7500-1	
Pumping medium allowed	Clean water Pure water Sea water Slightly contaminated water or fluids	● ○ ○ ○
Electrical connection	3~220-380V, 50Hz, ≤4kW 3~380V, 50Hz, >4kW other voltages/frequencies on request	● ● ○
Speed control	Control devices (Wilo control system) when using the corresponding Wilo switchgear	○
Special motor version (on request)	Special voltage/frequency and explosion-proof	○

- : Standard model
- : Special model, i.e. with additional equipment (plus supplement)

When ordering spare parts, please give all the information on the pump/motor rating plate.

2. Safety

These instructions contain important information which must be followed when installing and operating the pump. These operating instructions must therefore be read before assembly and commissioning by the installer and the responsible operator.

Both the general safety instructions in the "Safety precautions" section and those in subsequent sections indicated by danger symbols should be carefully observed.

2.1 Danger symbols used in these operating instructions

Safety precautions in these operating instructions which, if not followed, could cause personal injury are indicated by the symbol: 

when warning of electrical voltage with: 

The following symbol is used to indicate that by ignoring the relevant safety instructions, damage could be caused to the pump/machinery and its functions: 

2.2 Staff training

The personnel installing the pump must have the appropriate qualifications for this work.

2.3 Risks incurred by failure to comply with the safety precautions

Failure to comply with the safety precautions may endanger persons and pump/system. Failure to comply with the safety precautions could also invalidate any claim for damages.

In particular, lack of care may lead to problems such as:

- Injury resulting from electrical or mechanical factors.
- Failure of important pump or machinery functions.
- Failure of prescribed maintenance and repair procedures.
- Danger to the environment through emission of hazardous substances.

2.4 Safety precautions for the operator

Existing regulations for the prevention of accidents must be followed.

Dangers caused by electrical energy are to be excluded. Directives issued by the VDE [German Association of Electrical Engineers] and the local electricity supply companies are to be observed.

2.5 Safety information for inspection and assembly

The operator is responsible for ensuring that inspection and assembly are carried out by authorised and qualified personnel who have studied the operating instructions closely.

Work on the pump/machinery should only be carried out when the machine has been brought to a standstill.

2.6 Unauthorized modification and manufacture of spare parts

Alterations to the pump or installation may only be carried out with the manufacturer's consent. The use of original spare parts and accessories authorised by the manufacturer will ensure safety. The use of any other parts may invalidate claims invoking the liability of the manufacturer for any consequences.

2.7 Unauthorized operating methods

The operating safety of the pump or installation supplied can only be guaranteed if it is used in accordance with paragraph 1 of the operating instructions. The limiting values given in the catalogue or data sheet must neither be exceeded nor allowed to fall below those specified.

3. Transport and storage

3.1 Transport

3.1.1 General recommendations



Existing regulations for the prevention of accidents must be followed.

- The wearing of gloves, hard-toed boots and hard hats is compulsory for all transport work.
- Wooden cases, crates, pallets or boxes may be unloaded with fork-lift trucks or Using hoisting slings, depending on their size and construction.
- A hoist complying with local regulations must be used to lift heavy parts weighing more than 30 kg. The load-bearing capacity must be adapted to the weight.
- Only lifting hooks or shackles which comply with local safety regulations may be used to lift machines or parts using lugs. The carrying chains or cables must never be passed over or through the lugs or over sharp edges without protection.
- Lifting hooks, lugs or shackles may not be exposed to cantilever loads. Their load axis must lie in the direction of the tractive forces. When lifting ensure that the load limit of a cable is reduced for angled pulling.
- The safety and efficiency of a cable are best guaranteed if, wherever possible, all load-bearing elements are stressed vertically. If necessary a lifting arm should be used to which the carrying cable can be attached vertically.
- It is absolutely forbidden to stand beneath a raised load. In this connection the safety zone must be marked out such that there is no danger if the load or part thereof slips or the hoist breaks or tears. A load should never remain in a raised position for longer than necessary. Accelerating and braking during the lifting process must be performed such that there is no danger to persons.
- If a block and tackle or a similar hoist is used, it must be ensured that the load is lifted vertically. The raised load must be prevented from swinging. This can be achieved, for example, by using a second block and tackle, whereby the angle of pull of both should be less than 30° to the vertical.

3.1.2 Fitting the carrying cables



The hoists used must have a load-bearing capacity which corresponds to the weight of the pump set. The weight is indicated on the CE plate.



To avoid any distortion, please lift the pump set as shown.

Not by the ring lugs or on the free shaft end of the drive machine!

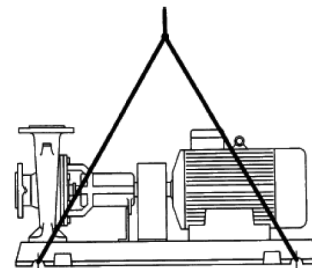

Fig. 1

3.2 Storage

Store the pump in a clean, dry and frost-free place where it is not exposed to vibrations. Weld the cover on the pipe connections so that no dirt or other foreign bodies can get into the pump housing. Rotate the pump shaft once a week to prevent striation of the bearings and the pump from seizing up.

Ask Wilo what preservation measures are necessary if a longer storage period is required.

4. Product and accessory description

4.1 Pump description

The Wilo-NX series pump is a single-stage centrifugal pump, with axial air intake and vertical pressure pipe, for installing foundations. Pump with support and flange-mounted bearing bracket, flexible coupling/expansion coupling, clutch guard and motor are mounted on a joint base.

4.2 Products delivered

- Complete pump
- Installation and Operating Instructions

4.3 Accessories

Accessories must be ordered separately.

- e.g. Wilo control system, see catalogue

4.4 Permissible forces and moments at the pump flanges

	Nominal size flange (DN)								
	≤50	80	100	150	200	250	300	350	400
Each top nozzle	Forces (N)								
F_x	710	1070	1420	2490	3780	5340	6670	7120	8450
F_y	580	890	1160	2050	3110	4450	5340	5780	6670
F_z	890	1330	1780	3110	4890	6670	8000	8900	10230
F_R	1280	1930	2560	4480	6920	9630	11700	12780	14850
Each end nozzle	Forces (N)								
F_x	890	1330	1780	3110	4890	6670	8000	8900	10230
F_y	710	1070	1420	2490	3780	5340	6670	7120	8450
F_z	580	890	1160	2050	3110	4450	5340	5780	6670
F_R	1280	1930	2560	4480	6920	9630	11700	12780	14850
Each nozzle	Moments (N*m)								
M_x	460	950	1330	2300	3530	5020	6100	6370	7320
M_y	230	470	680	1180	1760	2440	2980	3120	3660
M_z	350	720	1000	1760	2580	3800	4610	4750	5420
M_R	620	1280	1800	3130	4710	6750	8210	8540	9820

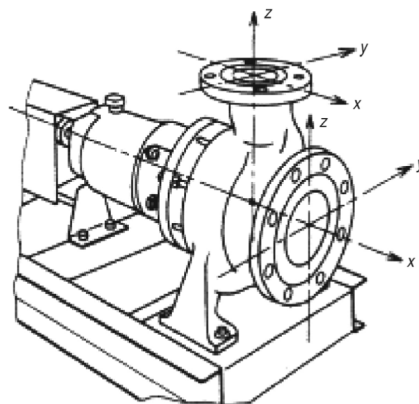

4.5 Expected noise values as guideline

power of motor PN [kW]	Sound pressure level pA [dB] ¹⁾ Pump alone		Pump with motor	
	1450 ⁻¹	2900 ⁻¹	1450 ⁻¹	2900 ⁻¹
<0.55	62	62	63	64
0.75	62	62	63	67
1.1	64	64	65	67
1.5	66	66	66	70
2.2	68	68	68	71
3	70	70	70	74
4	71	71	71	75
5.5	71	73	72	83
7.5	72	74	73	83
11	73	76	74	84
15	74	77	75	85
18.5	75	79	76	85
22	75	79	77	85
30	76	81	80	93
37	76	82	80	93
45	76	83	80	93
55	77	84	82	95
75	78	86	83	95
90	78	86	85	95
110	79	87	86	95
132	79	87	86	95
160	79	88	86	96

¹⁾ Without protective sound hood, measured at a distance of 1 m directly above the driven pump, in a free space above a sound reflecting surface.

5. Assembly / installation

5.1 Preparations

5.1.1 Unlacking and inspection

The pump must be checked for compliance with the information on the delivery note; Wilo must be notified immediately of any damage or missing parts. Check crates/boxes/wrappings of spare parts or accessories which could be enclosed with the pump.

5.1.2 Site

ATTENTION!

The pump must be installed protected from the elements in a frost- and dust-free, well-ventilated and non-explosive environment.

The pump must be installed such that there is space for access, ventilation, maintenance and testing and there is sufficient space above the pump for it to be lifted.

The suction pipe should be kept as short as possible.

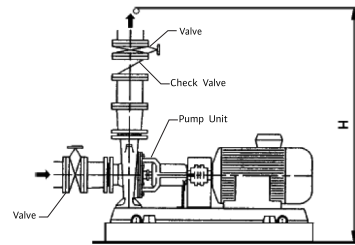

Fig. 3

5.1.3 Foundation

- The pump sets can be mounted on their foundations in many different ways; which of these methods is chosen depends on the size of the pump set, its site and the noise/vibration regulations.
- To install the pump so it is insulated against vibration it is necessary to simultaneously separate the foundation block itself from the body using a flexible insert (e.g. cork or Mafund plate).

ATTENTION!

A defective foundation or an incorrect installation of the set on the foundation could lead to a fault in the pump; this would not be covered by the warranty.

- The base must be mounted on a solid foundation, which must also be made from high-grade concrete of sufficient thickness. The base may NOT be distorted or pulled onto the surface of the foundation, but must be supported such that the original alignment remains unchanged.
- To anchor the base sufficiently, the dimensions of the fastening screws are selected / recommended in accordance with holes drilled in the base:

drilled in the base	Recommended screws		
	M	Length [mm]	threaded length [mm]
19	16	200	40
24	20	300	50
27~29	24	350	60

- The concrete foundation must have set before the pump set is installed. Its surface must be flat and even.

5.2 Installation

- When installed, the complete set is to be aligned on the foundation using a spirit level (with shaft/pressure pipe joint). The distance between the coupling halves in accordance with the installation plan is to be observed. Always fit dummy sheets (B) on left and right in the immediate vicinity of the fixing material (e.g. stone bolts (A)) between base (E) and foundation (D). If the fixing holes are longer than ≥ 800 mm additional dummy sheets are to be provided. All dummy sheets must fit snugly.
- Tighten fixing material evenly and securely.
- To further reduce vibration, after fixing, the base can be grouted with mortar which is as vibration-free as possible via opening (C) as far as the upper edge. Voids are to be avoided when doing so.

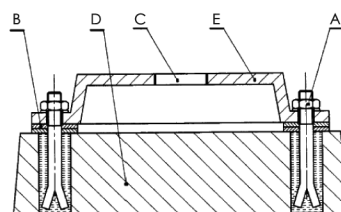



Fig. 4

5.2.1 Alignment of pump / motor

ATTENTION! The complete set has been aligned on the base by the manufacturer. After fixing the base the coupling must be carefully inspected and if necessary the set re-aligned (with the motor).

- Before beginning the alignment inspection or alignment loosen the support below the bearing bracket and re-tighten without stress.
- To re-align the coupling the 4 hexagonal screws of the motor base are to be loosened and this balanced with dummy sheets until the coupling is correctly aligned.
- The set is correctly aligned if a ruler placed axially across both coupling halves is at the same distance from the relevant shaft along its entire length, whereby it must be ensured that the measuring point is to be turned by hand. In addition, both coupling halves must be at an equal distance apart over their entire length (manufacturer's presetting of gap (S) = 3-5 mm). This is to be checked with callipers or gauge. (Fig. 5, fig. 6 with expansion coupling or reduction sleeve)
- The variation between the two coupling halves should not exceed 0.1- 0.15 mm radially and axially.
- These permissible variations are also to be guaranteed at operating temperature and increasing inlet pressure once the pipes have been successfully connected.

ATTENTION! Incorrect alignment of the set can result in damage to coupling and set!

 In accordance with the statutory provisions the coupling is to be protected by the safety device such that accidents caused by accidentally touching rotating parts are avoided.

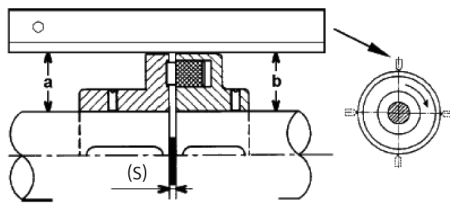

Fig. 5

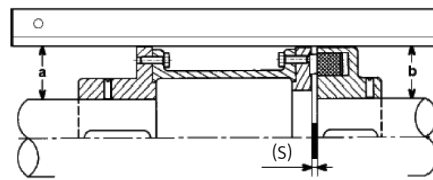

Fig. 6

5.3 Connecting the pipes

ATTENTION! Under no circumstances may the pump be used as a fixed support for the pipe!

- The available NPSH value of the system must always be greater than the required NPSH value of the pump.
- The forces and moments exerted on the pump flange by the pipe system (e.g. through twisting, thermal expansion) may not exceed the permissible forces and moments (see 4.4).
- The pipes are to be supported immediately before the pump and connected stress-free. Their weight may not place a strain on the pump.
- The suction pipe should be kept as short as possible. The suction pipe is to be fitted always rising to the pump, and falling to the inlet. Possible air pockets are to be avoided.
- If a catch pan is required in the suction pipe, its free cross-section must be equal to 3- 4 times the cross-section of the pipe.
- For short pipes the nominal widths must at least correspond to those of the pump connections. For long pipes the most economical nominal width is to be determined in each case.
- Transition pieces to larger nominal widths should be designed with an expansion angle of approx. 8° to avoid greater pressure losses.
- Shut-off devices before and after the pump (inspection or removal) as well as necessary non-return devices should in principle be provided.
- Only connect the pipes after all welding and soldering work is finished and the system has been cleaned / rinsed.
- The flange covers at the inlet and outlet pressure gland of the pump are to be removed before connecting the piping.
- When the eccentric reducer used for suction, installation must conform to the requirements as right (see figure 7).

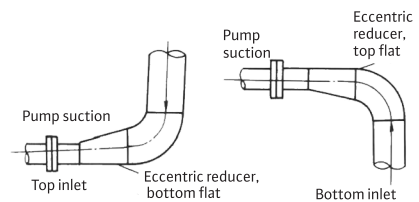

Fig. 7

5.4 Final inspection

The alignment of the set must be checked again in accordance with 5.2.1.

- If necessary re-tighten foundation screws.
- Check all connections for trueness and operation.
- If necessary re-align the set with the motor. Coupling/shaft must be able to be easily turned by hand.
- If pump uses oil lubrication, it shall ensure that use the correct bearing lube oil, and oil level shall be in the center of oil leveler.

5.5 Electrical connection



Electrical connection should be made by a qualified electrician. Current national regulations must be observed (e.g. VDE regulations in Germany).

- The supply cable must be laid in such a way that it never touches the pipework and/or the pump and motor casing.
- Check the mains current and voltage.
- Please observe data on the motor rating plate.
- Mains fuse: depends on nominal motor current.
- Observe earthing regulations.
- The connection diagram for the electrical connections can be found in the terminal box (see also fig. 8a, b, c).
- The special motor model is fitted with passive thermal control. These can be connected via the corresponding terminals in the terminal box.

The passive thermal control should be connected to the thermal trip mechanism.

ATTENTION!

At the binding posts a max. voltage of 7,5V= may be used. A higher voltage destroys the passive thermal control.

It is advisable to install a protective motor switch.

Adjusting the motor safety switch:

Direct starting current: the information on the motor rating plate must be observed for the installation on the nominal current;

Y-Δ-start: If the motor safety switch is connected as a star or triangular safety circuit combination at the supply line it can be adjusted in the same way units operating on direct starting current. If the motor safety switch is connected to the motor supply line in phase (U1/V1/W1 or U2/V2/W2), then the motor safety switch should be adjusted to the value of 0.58 of the nominal motor current.

- The mains connection on the tagboard depends on the power of the motor P_N, the power supply and the type of connection. The necessary connection of the bridges in the terminal box is illustrated in the following table and figure 8:

Type of switch	power of motor P _N ≤ 4kW		power of motor P _N > 4kW
	power supply		power supply
	3~220V	3~380V	3~380V
direct	Δ -connection (8a)	Y-connection (8b)	Δ -connection (8a)
Y- Δ -start	Remove connecting bridges (8c)	-	Remove connecting bridges (8c)

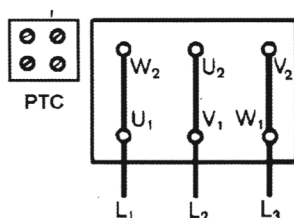

Fig. 8a

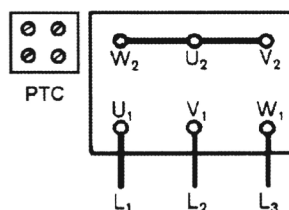

Fig. 8b

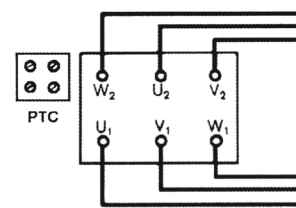

Fig. 8c

ATTENTION! Only check direction of rotation when system is full. Even brief dry running destroys the mechanical seal packing.

- Observe the installation and operating instructions when connecting automatically functioning acoustic implements.
- In the case of three-phase induction motors with Y-Δ-connection it must be ensured that the change-over points between star and triangle follow on from one another very quickly. Longer change-over times may result in pump damage.

Recommended time setting for Y-Δ-connection:

power of motor	Y-time t be set
≤30kW	< 3sec.
>30kW	< 5sec.

6. Operation

6.1 Initial start-up

- The pump, suction and supply pipes must be filled and the air must be removed.
Close blocking device at the outlet. Fill pump via the suction pipe, whereby the blocking device at the inlet is to be fully opened.
Fully deaerate pump via vent in pump housing, until only fluid appears. Close vent.

ATTENTION! Dry running damages the mechanical seal



Depending on the fluid temperature and the system pressure, if the vent screw is completely loosened hot liquid or gas can escape or even shoot out at high pressure. Beware of scalding.

- To avoid noise and damage resulting from cavitation, it is important to ensure a minimum supply pressure at the air intake of the pump. The minimum supply pressure depends on the location and point of operation and must be determined accordingly. Considerable parameters in determining the minimum supply pressure are the NPSH value of the pump at its operation point and the steam pressure of the flow medium.
- Check whether the direction of rotation is the same as that of the arrow on the pump housing by switching on the pump for a short period of time. If the direction of rotation is incorrect the following steps should be taken:
Direct start: exchange the 2 phases on the tagboard of the motor (e.g. L1 for L2),
Y-V-start: rearrange the location of the lead-in and lead-out wires on the tagboard of the motor (e.g. V1 for V2 and W1 for W2).

6.1.1 Switching on

- Only switch on the set when the blocking device at the outlet is closed!
Only open this slowly and set to the working point once full speed has been reached.
- The set must run smoothly and be free of vibrations.
- A mechanical seal guarantees a seal without leaks and does not require a specific setting. Any small leaks at the beginning will stop when the seal's run-in phase is complete.
- After the operating temperature has been reached and/or in the event of leaks in the pump housing, re-tighten the hexagonal screws with the set switched off. Check coupling alignment in accordance with 5.2.1 and if necessary re-tighten.



As soon as all work is finished, all scheduled safety and protective devices must be properly fitted and put into operation. If pump uses oil lubrication, it shall check whether the oil level declined obviously, and whether oil leakage occurred at bearing support.

6.1.2 Switching off

- Close blocking device in the compressed-air pipe.
If a non-return device is built into the compressed-air pipe, the blocking device can remain open provided there is a back-pressure.
- When switching off the pump the blocking device in the inlet pipe must not be closed.
- Switch off motor. Ensure quiet run-down.
- If the pump is out of operation for long periods the blocking device in the inlet pipe is to be closed.
- If the pump is out of operation for long periods and / or there is a risk of freezing the pump is to be drained or protected against freezing.

6.2 Operation

ATTENTION!

The pump should always run quietly and free from vibrations and not be operated at temperatures higher than those given in the catalogue/data specification sheet.

 Depending on the operating condition of the pump and/or installation (fluid temperature) the entire pump can become very hot. Avoid touching the pump owing to the risk of burning.

- The pump can be switched on and off in different ways, depending on the various operating conditions and the degree of automation in the installation. The following is to be observed:

Stop procedure: - Avoid reverse pump operation

- Do not work for too long with overly small transport capacities

Start procedure: - Ensure that the pump is completely full.

- Ensure a continuous flow to the pump with a sufficiently large NPSH value.
- Avoid an overly weak back-pressure causing the motor to overload.
- If pump uses oil lubrication, it shall keep oil level at the center of oil leveler.

- To avoid an excessive rise in temperature in the motor and excessive strain on the pump, coupling, motor, seals and bearings, the set should not be turned on more than 10 times per hour (h).

When pump is running, it shall check below items termly. If any abnormal found, it shall stop pump for inspection:

- Bearing: the pump oil level shall keep at the center of oil leveler, not too high or too low. Check bearing temperature, it shall be no more than the environment temperature 40°C, and the highest temperature shall be no more than 85°C.
- Mechanical seal: Generally, minor leakage is permitted, normally 3~5ml/h, but except toxic or valuable medium.
- The reading values of pressure vacuum gauge at suction and the pressure gauge at discharge shall be normal (if mounted)
- The motor electric current shall not exceed the rated current, otherwise it will heat up motor, and shorten the motor life.
- Pump running flow shall be no less than 30% of flow listed in nameplate.

6.3 Stop pump

- 1 Close the valves of suction vacuum gauge and discharge pressure gauge.
- 2 Slowly close the discharge valve. If a check valve mounted at discharge or a short stop, the discharge valve can keep open. When long term stop, repairing, or no check valve mounted at discharge, it must close the discharge valve.
- 3 Shut down the pump motor power supply. At the same time, shall pay attention if the rotor is stopped smoothly, slowly.
- 4 If there is a rapid cooling pipe, then the cooling pipe also should be closed.
- 5 Close valve in the auxiliary lines (if any). But the cooling pipe valve shall be closed after pump cooled.
- 6 If the ambient temperature is lower than 0 °C, liquid in the pump shall be drained, so as to avoid frost crack. If necessary it can use other protect measures.
- 7 If long stop pump, it shall remove the pump and oiled packaging for storage.

If any toxic, flammable and explosive, heat or other dangerous liquid drained from pump, it must not bring any harm to the people and environment.

7. Maintenance

7.1 General information

- The operator is responsible for ensuring that inspection and assembly are carried out by authorised and qualified personnel who have studied the operating instructions closely.
- By drawing up a maintenance plan, costly repairs can be avoided with a minimum of maintenance expense and a fault-free pump operation obtained. The Wilo Service is available for initial start-up and maintenance work.



Before carrying out any maintenance work, switch off the pump and ensure that it cannot be switched on again by unauthorized people. Never carry out work on a running pump.



Depending on the operating condition of the pump and/or installation (fluid temperature) the entire pump can become very hot. Avoid touching the pump owing to the risk of burning.

7.2 Routine maintenance

ATTENTION! If in the course of time the flexible elements of the coupling show signs of wear, these parts are to be replaced straight away.

- In principle all seals removed during maintenance work should be replaced.

The routine maintenance of the pump is very important, good maintenance can ensure the pump no abnormal stop occurred.

Recommended daily maintenance according to the following table.

Weekly	Check seal leakage. Check pump vibration. Check bearing temperature. Check the head change at rated flow. Check bearing lube oil level.
Every 3 months	Check the viscosity of bearing lube oil, and replace it termly.
Every 6 months	Check shaft seal, replace it if necessary. Check shaft and sleeve. Check the centering of pump and motor. Check tightness of pump bolts. Check the wear rate of coupling.
Yearly	Check the wear rate of rotating parts. Check the clearance of wear ring. Check bearing cleanness and wear rate.

7.2.1 Bearing brackets with rolling bearings

- For the models of NX250/500, NX300/320, NX300/400, it is necessary to periodical oiling the cylindrical roller bearings. For the other models, it is not necessary to do this process because of the maintenance-free bearing.

For the models of NX-A, NX-B and NX-C, it is necessary to periodical oiling the cylindrical roller bearings. The bracket is equipped with oil windows to observation oil level inside, and oil cups for oil level observation and automatic. The lube oil shall be complied with ISO VGA32 requirements, or using recommended or permitted oil. When it is very little oil or empty oil in oil cup, it shall be filled more. Generally, it is recommended that replace the lube oil after first 100 hours running, and then replace every 12 months.

7.2.2 Shaft seals

Pump with mechanical seal:

- When operating properly the mechanical seal has no visible leaks (only vapour). The mechanical seal is maintenance-free, its tightness is to be checked regularly. The slightest leak is a sign of the start of a tightness problem caused by damage to the components of the mechanical seal.

ATTENTION!

Minor leakage occurred in mechanical seal generally. The special clarification for seal leakage volume is necessary, the leakage volume is determined by many factors (such as size, material, pump medium, temperature, etc.). If large leakage occurred, it can be judged that seal is broken, and shall stop pump for repair, the broken parts must be replaced. During every disassembling of seal, auxiliary seal parts (such as O ring) must be replaced, rotate ring and static ring must be replaced. If pump shaft seal is mechanical seal, dry running is forbidden.



As soon as all work is finished, all scheduled safety and protective devices must be properly fitted and put into operation.

7.3 Disassemble and assemble

Disassemble pump shall follow below principles:

- Disassemble pump must be done by professional workers.
- Record the disassemble order of pump parts.
- When disassemble the parts with seal surface (such as mechanical seal), it shall be careful enough to avoid breaking the seal surfaces.
- If pulling out the parts from shaft difficultly, it can use some lube medium (such as lube oil), and pull it out.
- When replacing the O rings or gaskets, the new one size must be same with the old one.

Disassemble pump shall follow below steps:

- Disassemble the bolts of coupling guard, and remove the guard;
 - Remove the coupling spacer;
 - Disassemble the bolts between pump housing and cover, pull out the rotor part.
 - Disassemble the impeller nut (see figure 9), pull out the impeller.
- Disassemble the impeller nut

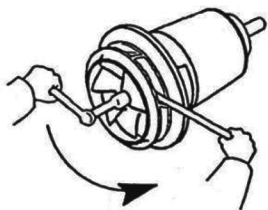

e. Remove pump cover; Fig.9

- Remove the pump coupling (see figure 10) and key by heating up.
- Disassemble the bolts of bearing housing, remove bearings and shaft.
- Disassemble the bearing nuts, remove bearings.

When re-assemble pump, it shall be in the reverse order of disassemble.

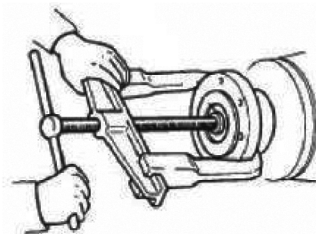

Fig.10

ATTENTION! During assemble, it shall check the clearance value of wear ring.

8. Problems, Caused and Solution

Item	Problem appearance	Possible cause and solution code for problem
1	Not pumping liquid normally	1,2,3,4,5,6,7,9,11,12,14
2	Not achieving designed flow	2,3,4,5,6,7,8,9,11,12,13,14,19,20
3	Not achieving designed head	2,3,4,5,6,7,8,9,11,12,13,14,18,19
4	Suction air after running	2,3,4,5,6,7,8,9
5	Shaft power too large	10,12,13,15,18,19,20,21,33,36,37,41
6	Abnormal pump vibration and noise	2,3,4,5,6,7,9,16,17,19,20,21,22,23,24,25,26,27,28,29,30,31,32,33,34,37,38,39,40,41,42,43
7	Pump over heating or not rotate	6,7,9,16,17,21,27,28,29,31,32,33,34,37,41
8	Inner clearance wear too quick	16,17,21,26,27,28,29,31,33,34,37
9	Mechanical seal overheated, or too much leakage	21,27,28,29,31,34,35,36
10	Bearing temperature too high, or failure too early	17,19,21,26,28,29,37,38,39,40,41,42,43
11	Coupling failure	21,26,28

Possible causes of problems, and solution codes are listed as below:

1. Cannot fill liquid in pump----Check related valves openess, and filling again.
2. Air in suction pipe----Air venting of pump and pipe completely, filling liquid completely.
3. Air in suction pipe cannot be vented----Add vent valve in this position, or change pipe arrangement.
4. Suction pipe leakage----Check pipe connection, check gaskets and bolt tightness.
5. Air pass the mechanical seal into pump----Check seal parts leakage.
6. Pump running when suction valve is close or partly close----Open pump suction valve.
7. Pump suction blocking----Clean suction pipe.
8. Pump suction frictional loss too much----Replace suction pipe.
9. Impeller blocking----Clean blocking.

10. Pump rotate speed too high----Choose proper speed.
11. Pump rotate speed too low----Choose proper speed.
12. Wrong rotate direction----Change motor rotate direction, or change motor.
13. Gauge not calibration----Calibrate all gauges before using.
14. Impeller actual diameter is less than design----Change impeller.
15. Impeller actual diameter is more than design----Cutting impeller diameter, or change impeller.
16. Running pump during bypass pipe and discharge pipe valve close----Running pump by right operation methods.
17. Pump running at the flow lower than designed minimum flow----Stop the wrong operation, running pump at the right flow.
18. Pump running at the flow higher than designed maximum flow---- Running pump at the right flow.
19. Clearance fit of parts is too large----Replace the parts.
20. Impurities in impeller----Clean impeller.
21. No centering between pump and motor----Adjusting coupling and centering.
22. Foundation rigidity is not enough----Increasing foundation rigidity by proper solution.
23. Foundation bolts are loose----Tight the bolts.
24. Mounted bolts between pump or motor and baseplate are loose---- Tight the bolts.
25. Foundation grouting is not enough----Grouting again.
26. Pipe load on the pump is to high----Adjusting the load on the pump by proper solution.
27. Pump main mounting surface is not perpendicular to the pump shaft center----Reassemble, to ensure the mounting surface is perpendicular to shaft center.
28. Shaft bending deformation----Replace the shaft.
29. Rotor balance quality is not enough----Reassemble, take the balance test for rotor.
30. Mounted part on the shaft is loose----Tight the part.
31. Bearing is wear out, causing the shaft eccentric running----Replace bearings.
32. Sympathetic vibration between pump and foundation or pipes----Change the intrinsic frequency, to avoid the sympathetic vibration.
33. Friction between rotating and static parts----Recheck the assemble, to ensure the clearance between rotating and static parts.
34. Hard particles enter into the clearance----Clean hard particles.
35. Seal flush pipe blocking----Disassemble pipe and clean.
36. Mechanical seal mounted incorrectly----Reassemble mechanical seal.
37. Too much thrust force caused by overwear of internal clearance----Replace wear parts.
38. Incorrect grade of grease or lube oil----Choose proper grease or lube oil.
39. Overoiling of grease or lube oil in bearing housing----Drained the grease or oil, fill correctly.
40. Lack of lubricating----Fill proper grease or lube oil.
41. Rolling bearings mounted incorrectly----Reassemble the bearings correctly.
42. Impurities enter into bearing----Clean bearing or replace new one.
43. Lube oil /grease is polluted----Replace new lube oil /grease.

9. Spare parts

ATTENTION! It is recommended that maintenance and repairs to the set only be carried out by Wilo or authorised experts.

- All spare parts necessary for maintenance or repair can be obtained from Wilo.
- To guarantee the fault-free operation of the pump/system only Wilo original spare parts are to be used. The use of other parts (modification or use of a non-standard part) may affect liability in respect of any consequences this may have.
- When ordering spare parts
 - The pump and motor rating plate,
 - Spare part names (see spare-parts list),
 - Mechanical seal part number (figure 11, figure 12 and figure 13).
 - and the number of spare parts required, must always be indicated.

9.1 Recommended stocking of spare parts for two-year continuous operation

9.1.1 NX pump

Part no.	Part Name	Number of pumps (including reserve pumps)						
		2	3	4	5	6 and 7	8 and 9	10 and more
		Number of spare parts						
5	Assembly-shaft	1	1	2	2	2	3	30%
4	Impeller	1	1	1	2	2	3	30%
17	Ball bearing	2	2	4	4	6	8	100%
15	Bearing bracket	–	–	–	–	–	1	2
–	Flat packing/O-rings(set)	4	6	8	8	9	12	150%
6.3	Mechanical seal	2	2	4	4	6	8	100%

9.1.2 NX- A pump , NX-B pump and NX-C pump

Part no.	Part Name	Number of pumps (including reserve pumps)						
		2	3	4	5	6 and 7	8 and 9	10 and more
		Number of spare parts						
4	Wear ring	2	2	4	4	6	8	100%
5	Assembly-shaft	1	1	2	2	2	3	30%
3	Impeller	1	1	1	2	2	3	30%
13	Roller bearing	1	1	2	2	3	4	100%
19	Ball bearing	2	2	4	4	6	8	100%
15	Bracket	–	–	–	–	–	1	2
–	Flat packing/O-ring(set)	4	6	8	8	9	12	150%
6.7	Mechanical seal	2	2	4	4	6	8	100%
21	Oil seal (NX-A)/Shield (NX-B, NX-C)	2	2	4	4	6	8	100%

9.2 Standard pump with mechanical seal

9.2.1 NX pump (fig.11)

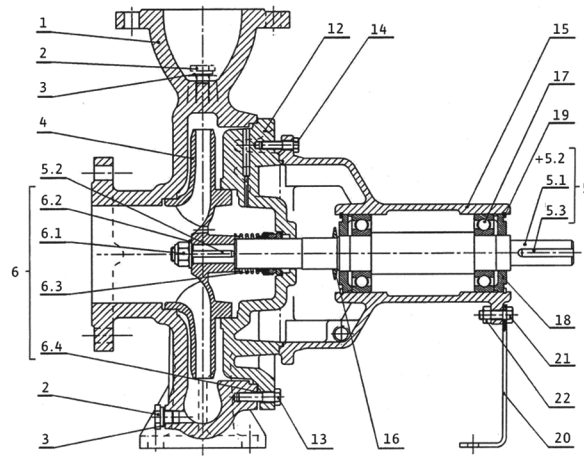

Fig.11

9.2.2 NX-A pump (fig.12)

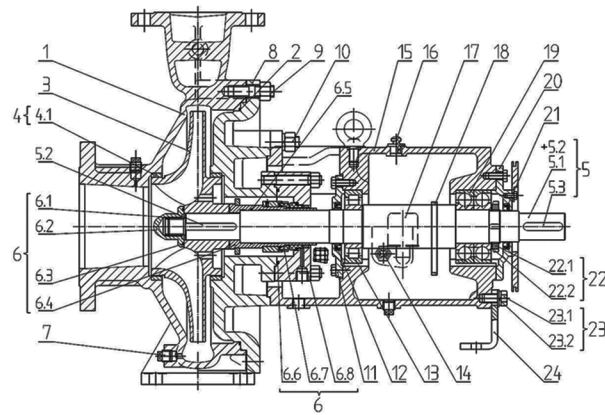

Fig.12

9.2.3 NX-B pump and NX-C pump (fig.13)

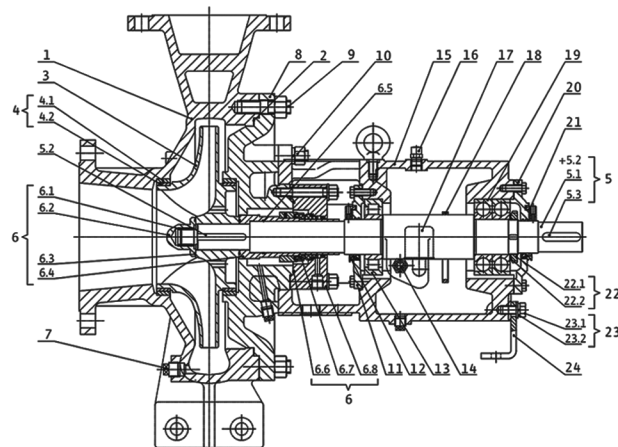

Fig.13

9.3 Spare-parts list

9.3.1 NX pump

Part number (Fig. 11)	Number	Part Name
1.	1	Pump housing
2.	2	Screw plug
3.	2	Sealing washer
4.	1	Impeller
5.	1	Assembly-shaft
5.1	1	Shaft
5.2	1	Key
5.3	1	Key
Model with mechanical seal		
6.	1	Mechanical seal device
6.1	1	Hexagonal nut
6.2	11	Washer
6.3	1	Mechanical seal (complete)
6.4	1	Housing seal
12.	1	Pressure cover
13.	12	Hexagonal head screw
14.	12	Hexagonal head screw
15.	1	Bearing bracket
16.	1	Thrower
17.	2	Ball bearing
18.	2	Bearing cover
19.	2	Circlip
20.	1	Support
21.	1	Hexagon head screw
22.	1	Hexagonal nut

9.3.2 NX- A pump , NX-B pump and NX-C pump

Part number (Fig. 12 and Fig. 13).	Number	Part Name
1.	1	Pump housing
2.	1	Housing seal
3.	1	Impeller
4.	2	Wear ring
4.1	2	Housing wear ring
4.2	2	Impeller wear ring (Only NX-B, NX-C)
5.	1	Assembly-shaft
5.1	1	Shaft
5.2	1	Key
5.3	1	Key
6.	1	Mechanical seal device
6.1	1	Wire thread
6.2	1	Impeller nut
6.3	2	O-ring
6.4	1	Sleeve
6.5	1	O-ring
6.6	1	O-ring
6.7	1	Mechanical seal (complete)
6.8	1	Gland
7.	1	Screw plug
8.	1	Pressure cover
9.	According to pump	Stud
10.	According to pump	Stud
11.	1	Bearing cover
12.	1	Oil seal (NX-A) /Shield (NX-B, NX-C)
13.	1	Roller bearing
14.	1	Oil level indicator
15.	1	Bracket
16.	1	Breather valve
18.	1	Splash ring
19.	2	Ball bearing
20.	1	Bearing cover
21.	1	Oil seal (NX-A) /Shield (NX-B, NX-C)
22.	1	Bearing lock device
22.1	1	Lock nut
22.2	1	Lock washer
23.	1	Adjust device
23.1	1	Hexagonal head screw
23.2	1	Washer

目 录

1.	概述	2
1.1	使用范围	2
1.2	产品技术参数	2
1.2.1	型号说明	2
1.2.2	技术参数	2
2.	安全说明	3
2.1	说明书中使用的符号	3
2.2	操作人员资质	3
2.3	不遵守安全准则的危害	3
2.4	操作者的安全准则	3
2.5	检查和安装的安全规范	3
2.6	自行改装设备和自制备件	3
2.7	不允许的运行情况	3
3.	运输和存储	4
3.1	运输	4
3.1.1	一般建议	4
3.1.2	安装起重吊索	4
3.2	存储	4
4.	产品和附件	4
4.1	水泵	4
4.2	供货范围	4
4.3	附件	4
4.4	水泵法兰允许承受的力和力矩	5
4.5	噪音参考值	6
5.	安装	7
5.1	准备	7
5.1.1	开箱检查	7
5.1.2	安装地点	7
5.1.3	基础	7
5.2	安装	7
5.2.1	水泵和电机的轴对中	8
5.3	管路连接	8
5.4	最后检查	8
5.5	电气连接	9
6.	调试	10
6.1	首次启动	10
6.1.1	启动	10
6.1.2	关闭	10
6.2	运转	10
6.3	停机	11
7.	维护	11
7.1	概述	11
7.2	常规保养	11
7.2.1	滚动轴承和托架	11
7.2.2	机械密封	12
7.3	拆卸与装配	12
8.	故障，故障原因及排除	14
9.	零部件	16
9.1	建议提供保留 2 年的零部件	16
9.1.1	NX 泵	16
9.1.2	NX-A泵、NX-B泵和NX-C泵	16
9.2	水泵结构图	17
9.2.1	NX 泵（图 8）	17
9.2.2	NX-A泵、NX-B泵和NX-C泵（图9）	17
9.3	零部件清单	18
9.3.1	NX 泵	18
9.3.2	NX-A泵、NX-B泵和NX-C泵	19

1. 概述

该水泵的安装和维护只能由相应的专业人员来完成。

1.1 应用范围

威乐 NX 系列水泵 可适用于 输送清水、海水、轻油类或生产工艺流程中其它类似于水但具有一定腐蚀性或需要防止污染的无固体颗粒及不易结晶的液体介质。

- 海水淡化
- 纯水系统
- 一般工业

1.2 产品技术参数

1.2.1 型号说明

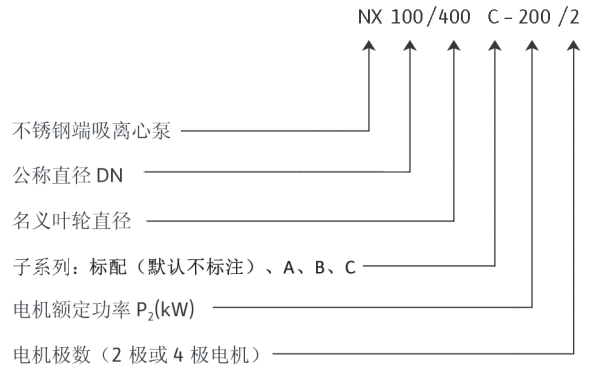

1.2.2 技术参数

转速:	2900, 1450 1/min	
水泵进出口名义管径 DN:	32~300	
允许介质温度	-20°C~+120°C 机械密封 -30°C~+130°C 机械密封 (适用于NX-B/NX-C)	
最高允许环境温度	40°C	
最大允许工作压力	16 bar: 适用于NX 25 bar: 适用于NX / NX-A / NX-B 30 bar: 适用于NX-C	● ○ ○
电机绝缘等级	F	
电机防护等级	IP55	
电机保护	PTC 传感器	
管路连接	法兰 PN16(PN25)(PN40) 根据DIN 2533 / ISO 7005-1	
允许介质	普通清水 纯水 海水 弱腐蚀液体	● ○ ○ ○
电源	3~220-380V, 50Hz, ≤4kW 3~380V, 50Hz, >4kW 其他电压 / 频率 (请来函咨询)	● ● ○
转速控制	控制装置 (威乐控制系统) 使用威乐的开关装置	○
特殊电机	特殊电压 / 频率和防爆电机	○

- : 标准配置
- : 特殊配置或附加配件 (需另外加价)

在订购配件时, 一定要给出水泵和电机铭牌上所有的技术参数。

2. 安全准则

此说明书中涵盖了该水泵安装及运行时必需严格遵守的安全准则。因此，安装人员和操作者在安装和调试水泵前必需认真阅读此说明书。

安全防范部分的安全须知和后面部分中特殊安全标志表示的安全规则都必需认真遵守。在阅读中，一定要注意安全规范，尤其是一些特殊标志的说明。

2.1 操作说明书中使用的标志说明

如不遵守操作说明书中的安全防范措施将引起人身伤害，表示符号：

危险，有电，表示符号：

忽视有关的安全防范措施将对水泵和机械设备及其功能造成损坏，表示符号：

2.2 操作人员资质

安装水泵的人员必须有相应的资质。

2.3 不遵守安全准则的危害

不遵守安全防范措施将引起人身伤害或水泵损坏，厂方不负任何责任，也不承担任何索赔。

具体地说，不遵守安全防范措施将导致以下危害：

- 造成电气或机械伤害。
- 水泵或设备将失去其主要或重要功能。
- 维护和维修过程造成的损害。
- 有害物质的散发对环境造成损害。

2.4 操作者的安全准则

必须遵守本说明书中的预防事故发生的重要规范。

排除可能引起的电能伤害。必须遵守 VDE 规范（德国电气工程师协会规范）以及当地的电气规程。

2.5 检查和安装的安全规范

操作者有责任确保检查和安装水泵必须由有资质的、授权批准的专业人员进行。

只有在水泵停止运行时，才能进行检修。

2.6 自行改装设备和自制备件

自行改装设备必须经过制造商同意，使用原厂备件将确保安全。使用其他零件，制造商将不承担由此引起的任何后果和责任。

2.7 不允许的运行情况

严格遵守说明书的第一章规定才能确保设备运行安全。在产品样本及数据表中的极限值不允许逾越。

3. 运输与存储

3.1 运输

3.1.1 一般建议



必须遵守安全防范措施。

- 在搬运过程中，必须带手套，穿工作鞋和戴安全帽。
- 根据尺寸和结构选用叉车或提升装置来卸木箱、板条箱或货盘。
- 根据当地规范必须使用提升装置起吊重量超过 30Kg 的起吊部件。
- 只可用当地安全条例许可的吊钩来提升设备或部件。当通过突出部分或尖角时，链条或缆绳必须有保护。
- 用暴露吊钩不能直接挂载重物。重物轴线必须位于牵引力的方向上。起吊时，应考虑因存在牵引角，缆车承受力的减少。
- 所有负载均为垂直方向时，缆车最为安全和高效。必要时要使用缆车能垂直到达的起重臂。
- 禁止站立在起吊的重物之下。应标出一个安全区域，当重物或部件滑落或提升装置断裂时，保证人员安全。禁止让重物长时间处于起吊状态中。在起吊过程中加速和刹车必须对人员无危险时进行。
- 如果使用滑轮或类似提升装置时，必须确保重物垂直提升。提升重物时必须防止摇晃。这个很容易达到，例如，采用副滑轮和滑车，但其两受力绳的垂直夹角必须小于 30°。

3.1.2 安装起重吊索



起重装置的承载力必须大于泵组设备的重量，水泵的重量可在水泵铭牌上查到。



为了避免损坏，请按照下图提升水泵设备。

不得从电机吊环或电机轴端处起吊。



图 1

3.2 存储

水泵应存放在干净，干燥和无霜冻的环境中，严禁受到外力损害。为防止灰尘或异物进入泵体，在水泵的进出口放上盖板。每周旋转泵轴一次以防止轴承产生纹痕和轧住。

若需长期储存请咨询威乐公司，必须采取保护措施。

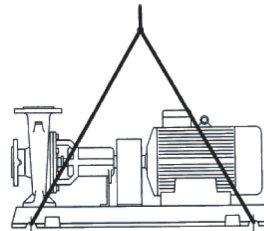
4 产品和附件

4.1 水泵

威乐 NX 系列水泵为单级离心泵，带有支撑和轴承座，联轴节及联轴节防护罩的水泵和电机安装在一个整体的基础上。配备符合 IEC 标准的电机。

4.2 供货范围

- 水泵
- 安装使用说明书

4.3 附件

附件必须另行订购。

- 例如，威乐的控制系統。

4.4 水泵法兰允许承受的力和力矩

	法兰公称直径 (DN)								
	≤50	80	100	150	200	250	300	350	400
每个顶部管口	力 (N)								
F_x	710	1070	1420	2490	3780	5340	6670	7120	8450
F_y	580	890	1160	2050	3110	4450	5340	5780	6670
F_z	890	1330	1780	3110	4890	6670	8000	8900	10230
F_R	1280	1930	2560	4480	6920	9630	11700	12780	14850
每个端部管口	力 (N)								
F_x	890	1330	1780	3110	4890	6670	8000	8900	10230
F_y	710	1070	1420	2490	3780	5340	6670	7120	8450
F_z	580	890	1160	2050	3110	4450	5340	5780	6670
F_R	1280	1930	2560	4480	6920	9630	11700	12780	14850
每个管口	力矩 (N*m)								
M_x	460	950	1330	2300	3530	5020	6100	6370	7320
M_y	230	470	680	1180	1760	2440	2980	3120	3660
M_z	350	720	1000	1760	2580	3800	4610	4750	5420
M_R	620	1280	1800	3130	4710	6750	8210	8540	9820

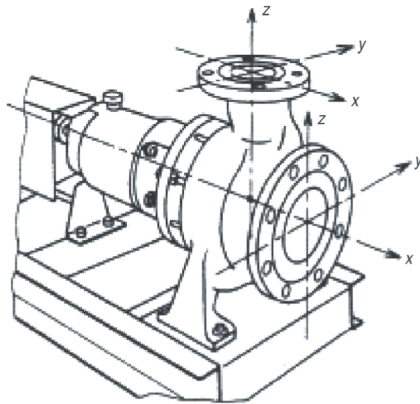

4.5 噪音参考值

电机功率 [kW]	声压级 PA [dB] ¹⁾ 泵头		声压级 PA [dB] ¹⁾ 水泵和电机	
	转速 1450 ⁻¹	转速 2900 ⁻¹	转速 1450 ⁻¹	转速 2900 ⁻¹
<0.55	62	62	63	64
0.75	62	62	63	67
1.1	64	64	65	67
1.5	66	66	66	70
2.2	68	68	68	71
3	70	70	70	74
4	71	71	71	75
5.5	71	73	72	83
7.5	72	74	73	83
11	73	76	74	84
15	74	77	75	85
18.5	75	79	76	85
22	75	79	77	85
30	76	81	80	93
37	76	82	80	93
45	76	83	80	93
55	77	84	82	95
75	78	86	83	95
90	78	86	85	95
110	79	87	86	95
132	79	87	86	95
160	79	88	86	96

¹⁾ 平均声压级值指在距电动机表面 1 米的空间区域测量的。

5. 安装

5.1 准备

5.1.1 开箱检查

水泵必须按发货单检查；任何损坏或丢失情况必须立即告知威乐公司。并检查随泵封在一起的备件或附件的包装。

5.1.2 安装地点

注意! 水泵必须安装在无霜冻无尘，通风良好，无爆炸的环境中。

水泵应安装在宽敞、通风、方便维修和测试的地方，以及还须有足够的空间用于水泵的提升。

进水管道应尽可能的短。



图 3

5.1.3 基础

- 水泵可以采取不同的安装方式；根据水泵的尺寸，地点和噪音 / 振动选择安装方法。
- 为了隔振，安装水泵时必须在基础与泵体间加入弹性垫层（如：软木垫圈，隔振板）。

注意! 有缺陷的基础或不在基础上正确的安装会导致水泵故障；而这不属于质保范围。

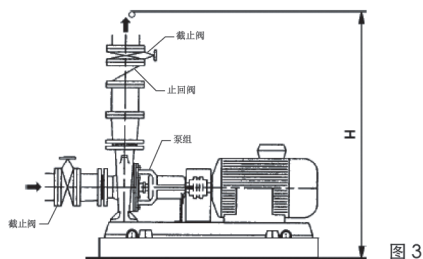
- 水泵必须安装在牢固的基础上，基础必须由足够厚的高等级混凝土作成。水泵的基础不允许变形。
- 为了固定基础，对于不同基础的孔径我们推荐不同的螺栓：

底板孔径	推荐螺栓		
	M	长度 [mm]	螺纹长度 [mm]
∅ [mm]			
19	16	200	40
24	20	300	50
27~29	24	350	60

- 混凝土基础应在水泵安装之前做好。其表面应平整光滑。

5.2 安装

- 水泵放在基础上通过水平仪进行校准（轴 / 管道连接后）。根据安装指导检查两个半联轴器间的距离。首先把橡皮垫圈（B）放在的底座（E）与基础（D）之间，紧靠安装材料（如地脚螺栓 A）左侧和右侧。如果安装孔大于 800 毫米，需额外的橡胶垫。所有的橡胶垫必须是合适的。
- 均匀拧紧固定材料。
- 为了进一步避免振动，固定后，基座可以通过上面的开口（C）用水泥浆填塞，这样可以在运行过程中最大可能的减少振动。填充时，要避免空隙。



图 4

5.2.1 水泵和电机的轴对中

注意! 全部设备已经由制造商进行过轴对中。固定在基础上后，必须认真检查联轴节，如有必要，重新调整轴对中。

- 在进行轴对中前松开轴承托架下的支撑，然后重新拧紧。
- 为了重新对轴进行对中，松开电机座的 4 个底脚螺栓，调整橡胶垫圈直到联轴节正确的轴对中。
- 如果在联轴节端面间放入一个标尺，使轴间具有同样的间距，由此必须确保测量点可以手动转动。另外，两个联轴节间必须具有相等的距离（制造商规定的最小间隙 = 3-5mm），这可以用量具或量规检查。（图 5，图 6）
- 两联轴节间的跳动不应超过 0.1-0.15mm。
- 管路连接后介质达到运行温度，须保证联轴器的跳动值仍在规定范围内。

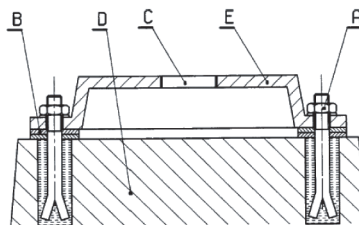
! 水泵的不正确的轴对中可能导致联轴节和水泵的损坏。

注意! 根据当地规范，联轴节通过安全装置保护，避免直接接触旋转部件，防止事故的发生。



图 5



图 6

5.3 管路连接

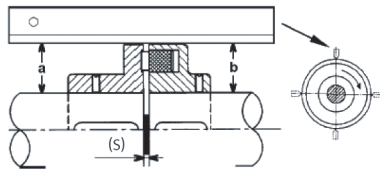
注意! 任何情况下水泵都不能作为管路的支撑承重基础。

- 管路系统的 NPSH 值必须大于水泵要求的 NPSH 值。
- 管路系统（例如扭曲，热膨胀）对泵法兰的压力和力矩不能超过允许的压力和力矩（见图 4.4）。
- 管路必须在泵安装前支撑好，并避免应力。不得将其重量加在泵上。
- 进水管尽可能短。进水管的安装应先提升到泵上端，再下落到泵进口。避免空气进入。
- 如果要在进水管路上安装集水盘，其截面积必须是管路的 3-4 倍。
- 短管的公称尺寸至少与水泵接口相一致。长管的公称尺寸视具体情况而定。
- 过渡到更大截面管路时，扩展角设计应在 8° 左右以防止较大的水力损失。
- 原则上泵前后端应配截止阀或止回阀以满足检修或拆卸搬运的需要。
- 只能在管路焊接工作完成和管道系统被清洁冲洗后方可连接管路系统。
- 在连接管路之前，进、出口法兰盖须拆除。
- 进水管安装偏心变径管时，安装时要符合右图要求（见图 7）。

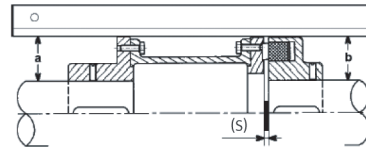

图 7

5.4 最后检查

必须按照 5.2.1 再次检查水泵的对中。

- 如有必要重新拧紧基座的螺钉。
- 检查所有的连接。
- 如有必要，对电机进行重新对中。联轴节 / 轴必须用手就可以轻松的盘动。
- 如泵采用稀油润滑，应保证使用正确的轴承润滑油，且油位处于油标中心位置。

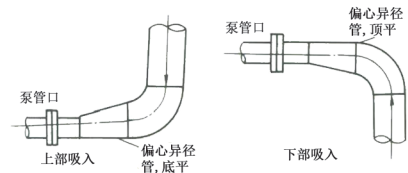
5.5 电气连接

 电气连接必须由有资格的电工完成。必须遵守当前的国家法规（例如德国的 VDE）。

- 必须避免电源线与管路 / 水泵和电机壳体接触。
- 检查主电源和电压。
- 检查电机铭牌上的数据。
- 电源保险丝：根据电机满负载电流决定。
- 遵守接地规程。
- 电源接线图在接线盒内表面上（见图 7a,b,c）。
- 特殊类型的电机采用温度控制。它们可以通过对应的终端在接线盒里进行连接。
- 温度控制应与热断路装置连接。

注意! 附带的说明上允许使用的最大电压为 7.5V。高压会毁坏温度控制元件。

- 安装电机保护开关。
- 调节电机保护开关：

直接启动：根据电机铭牌上的参数设定额定电流。

Y- Δ 启动：如果电源线和电机保护开关的连接是星形或三角形安全电路的组合，可以采用和设备直接启动电流相同的调节方式。如果电机安全开关是按相（U1/V1/W1 或 U2/V2/W2）连接的，那么电机安全开关应调节到电机额定电流的 0.58 倍。

- 电源的连接方式由电机额定功率 P_2 ，电压和启动方式而定。搭桥连接参照下表和图 7。

启动方法	电机功率 $P_N \leq 4kW$		电机功率 $P_N > 4kW$
	主电源		主电源
	3~220V	3~380V	3~380V
直接启动	Δ - 连接 (7a)	Y- 连接 (7b)	Δ - 连接 (7a)
Y- Δ -start	去除连接桥 (7c)	-	去除连接桥 (7c)

注意! 当系统充满后才能检查水泵转向，短暂的干转也会损坏机械密封。



图 8a



图 8b

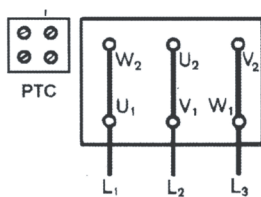

图 8c

- 连接自动运行装置时，要遵守安装运行指导书。
- 三相感应电动机采用 Y- Δ 连接时，必须保证 Y 和 Δ 转换点快速的切换。过长的转换时间会对水泵造成损坏。

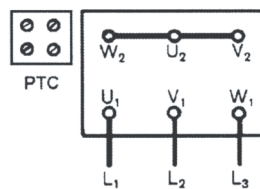
推荐 Y- Δ 连接的时间设置：

电机功率	切换时间设定
$\leq 30kW$	< 3sec.
> 30kW	< 5sec.

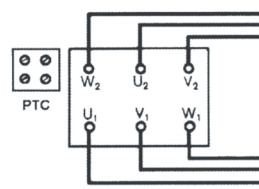
6. 调试

6.1 首次启动

- 泵体，进水管路必须注满介质，且必须排出空气。
关闭出口阀门。完全打开进口阀门使泵注满水。通过泵体的排气阀，使水泵完全除去空气，直到液体流出。关闭排气阀。

注意! 禁止水泵干转。干转会损坏机械密封。

 根据介质温度和系统压力，如果完全拧松放气螺栓，热的液体或气体就会在高压下喷出。小心烫伤!

- 为了避免气蚀造成的噪音和破坏，必须确保进水口的最小进口压力。最小进口压力根据水泵的运行条件及水泵的工况点决定，必须进行相应的计算。决定最小进口压力的参数是水泵的 NPSH 值和介质的汽化压力。
- 点动水泵，检查水泵的转动方向，确保转动方向与电机上所示箭头一致。如果转动方向不一致，请按如下操作：
直接启动：调换电机接线的任意两相（例如 L1 和 L2）。
Y- Δ 启动：调换任意 2 个绕组的电机接线（例如 V1 和 V2 调换，W1 和 W2 调换）。

6.1.1 启动

- 只有出口阀门关闭时才能启动。
缓慢地开动水泵，并在到达全速时调节到工作点。
- 系统必须平稳运转，无异常振动。
- 保证机械密封没有泄露，且不需要特殊的装置。当密封的试车状态完毕，如有任何的泄露，要停止运转。
- 在达到操作温度和发生泵体泄露后，关闭水泵，重新拧紧螺丝。根据 5.2.1 检查联轴节对中。

 一旦所有准备工作结束，必须保证所有的安全和保护装置正确安装，并投入使用。
如水泵为稀油润滑，需观察油位是否明显下降，轴承支架是否有润滑油泄漏情况。

6.1.2 关闭

- 关闭出口管路的闸阀。
如果在出口管路安装了止回阀，有负压情况下，闸阀可以保持开启状态。

 当关闭水泵时，进口管路的闸阀一定不能关闭。

- 关闭电机。停泵应平稳。
- 如果水泵长时间不运转，关闭进口管路的闸阀。
- 如果水泵长时间不运转 / 有冰冻的危险，放空水泵或采取防冻措施。

6.2 运转

注意! 水泵应该保持平稳运转，无异常振动，且不能在高于样本 / 技术说明书规定的温度下运转。

 由于水泵的安装和运行情况不同，水泵可能会很热。避免接触水泵而造成烫伤。

- 水泵可以以不同的方式开启和关闭，要根据不同的运行条件和设备安装时的自动化程度而定。

遵守的规则如下：

- 停止过程：
- 避免水泵反转
 - 不要让水泵长时间低流量运转

- 启动过程：
- 确保水泵完全注满了介质。
 - 确保水泵具有足够大的 NPSH 值的连续流量。
 - 避免背压过低，防止电机过载。
 - 如泵采用稀油润滑，应保持油位在油标中心位置。

- 避免电机温度过高，避免水泵、联轴节、电机、密封和轴承的应力过大，电机每小时启动次数不能超过 10 次。

泵在运转时，应定期检查如下项目，如发现异常情况应停机检查：

- a. 轴承：泵轴承油位应保持在油标中心位置，不能过高或过低。检查轴承温度，轴承温度一般不超过环境温度40℃，但最高温度不应超过85℃。
- b. 机封：通常情况下，机封允许少量泄漏，正常为3~5ml/h，但有毒或贵重介质除外。
- c. 吸入管路压力真空表和排出管路上压力表读数正常（如有安装）。
- d. 电机电流不超过电机额定电流，否则电机会发热，减短电机寿命。
- e. 泵运行流量不低于铭牌上流量的30%。

6.3 停机

泵的停机建议按如下步骤进行：

- 1 关闭进口管路压力真空表和出口管路压力表闸阀。
- 2 缓慢关闭出口闸阀。如果出口管路上安装有逆止阀或者是短时期停车，出口阀能够继续开着。当长期停车、维修或没有设置逆止阀时，必须关闭出口管路上的阀。
- 3 关闭水泵电机电源。同时注意转子是否是平稳、缓慢的停止。
- 4 如果存在急冷管路，那么冷却管路也应该关闭。
- 5 关闭辅助管路上的阀门（若有），但冷却水阀门应在泵冷却后再关闭。
- 6 若环境温度低于0℃，应将泵内液体放出，以免冻裂。如果必要可使用其它一些保护措施。
- 7 若长期停止使用，应将泵拆卸上油并包装保管。

泵体所排出的有毒、易燃易爆、热的或其它危险的残液，不允许对人及环境带来任何危害。

7. 维护

7.1 概述

- 操作人员必须确认检查和装配系统的人员必须是认真研究了操作手册的有资格和授权的合格人员。
- 通过制定维护计划，降低维护成本，使泵长期正常运转。威乐售后服务负责维护工作。



在进行维护和维修工作之前，关闭水泵，确保无关人员不会触动开关。一定不要对运转的水泵进行保养。



由于水泵的安装和运行情况（流体温度）不同，水泵可能会很热。避免接触水泵而造成烫伤。

7.2 常规保养

注意! 如果联轴节的部件有磨损，应马上更换。

- 通常所有在保养时拆下的机械密封应该更换。

泵的日常维护工作十分重要，较好的日常维护能确保泵非正常强制停机，建议按如下表进行日常维护。

每星期	检查轴封泄漏。 检查泵的振动。 检测轴承温度。 检查额定流量下的扬程变化量。 检查轴承润滑油量。
每 3 个月	检查轴承润滑油粘度并定期更换。
每 6 个月	检查轴封，需要时更换。 检查轴或轴套。 检查泵和电机的同轴度。 检查压紧螺栓的紧固性。 检查联轴器的磨损。
每 年	检查转动部件的磨损。 检查密封环的间隙。 对轴承清洁，检查磨损情况。

7.2.1 滚动轴承和托架

- NX250/500、NX300/320、NX300/400 使用圆柱滚子轴承需要定期给轴承加注润滑油脂，其它型号水泵使用免维护轴承，不需要定期加油维护。

NX-A泵、NX-B泵和NX-C泵使用滚动轴承，采用稀油自润滑方式。托架上配备可视油窗和油杯，用于观察油位和自动补充润滑油。润滑油需符合 ISO VG32 的要求，或者使用推荐或允许使用的油脂类型。当油杯中润滑油很少或没有时，应立即补充。通常条件下，建议首次运行 100 小时后重新更换润滑油，以后每隔 12 个月更换一次。

不能重新使用拆卸下的滚动轴承！

7.2.2 机械密封

机械密封：

- 正常运转时，机械密封无明显的泄露。机械密封不需特殊的保养，定期检查紧固性。轻微的泄露可能是机封损坏的信号。

注意：

机械密封通常存在小的泄漏量。关于密封泄露的特殊说明仍然是有必要的，密封的泄漏量取决于很多不同的因素（如：尺寸、材料、泵送介质、温度等）。当密封液有较大泄漏时，可断定密封件已损坏，应立即停车检修，损坏的部件必须更换。在每次装拆密封时，辅助密封件（如：O形圈）必须重新更换，动静环也必须一起更换。

水泵轴封为机械密封时，绝对不允许干转。



一旦所有准备工作结束，必须保证所有的安全和保护装置正确安装，并投入使用。

7.3 拆卸与装配

拆装水泵应遵循的原则如下：

- 拆装水泵必须由专业技术人员实施。
- 记录水泵部件拆卸的顺序。
- 带密封表面的部件(如机械密封)，拆装时必须格外小心，以防止损害密封面。
- 从轴上卸下部件十分困难时,可使用润滑介质(如润滑油)进行润滑,再将部件取下。
- 更换泵体O形圈或垫片时,新旧O形圈与垫片尺寸、规格必须与原来保持一致。

建议按如下步骤拆卸水泵：

- a. 拆除联轴器的防护罩的紧固螺栓，取下防护罩；
 - b. 取下加长膜片联轴器中间的中段；
 - c. 拆除泵体和泵盖间的紧固螺母，拉出转子部件；
 - d. 拧去叶轮螺母（见图 9），取下叶轮；
- 叶轮螺母拆卸



图 9



图 10

- e. 拆除泵盖；
- f. 以火烤加热的方式，拆下泵端联轴器（见图10）及泵联平键。
- g. 拧去悬架两端轴承压盖紧固螺栓，取出轴承及泵轴；
- h. 拧下轴承锁紧螺母，拆除轴承。

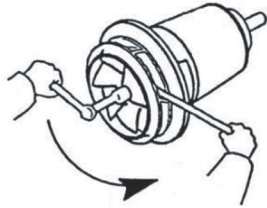
重新组装水泵时，其顺序和拆卸水泵的顺序相反。

注意! 装配时，应检查密封环的间隙数值。

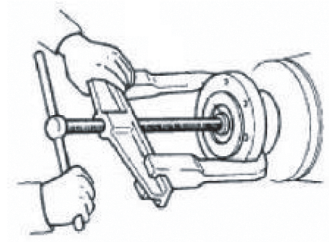
8. 故障，故障原因及排除

序号	故障征兆或现象	故障产生的可能原因及处理措施代码
1	无法正常输送液体	1,2,3,4,5,6,7,9,11,12,14
2	无法达到设计流量	2,3,4,5,6,7,8,9,11,12,13,14,19,20
3	无法达到设计扬程	2,3,4,5,6,7,8,9,11,12,13,14,18,19
4	启动后泵入口抽空	2,3,4,5,6,7,8,9
5	轴功率过大	10,12,13,15,18,19,20,21,33,36,37,41
6	泵振动或噪声异常	2,3,4,5,6,7,9,16,17,19,20,21,22,23,24,25,26,27,28,29,30,31,32,33,34,37,38,39,40,41,42,43
7	泵过度发热及转不动	6,7,9,16,17,21,27,28,29,31,32,33,34,37,41
8	内部间隙磨损过快	16,17,21,26,27,28,29,31,33,34,37
9	机械密封发热或泄漏量超标	21,27,28,29,31,34,35,36
10	轴承温度过高或过早失效	17,19,21,26,28,29,37,38,39,40,41,42,43
11	联轴器故障	21,26,28

故障产生的可能原因及处理措施代码详细内容如下：

- 1.泵无法灌注液体----检查与灌注相关阀门是否打开,再次灌注液体;
- 2.泵吸入管路内留有空气----泵与管路彻底排气并完全灌满液体;
- 3.吸入管路中存有无法排出空气----在该位置增加放气阀排气或改变管路设置;
- 4.吸入管路漏气----检查入口连接情况,确认垫片完好及螺栓是否把紧;
- 5.空气通过机械密封渗入泵内----检查密封连接部件是否漏气;
- 6.泵在关闭或部分关闭入口阀门的情况下运行----打开泵的入口阀门运行;
- 7.吸入管路阻塞----清理吸入管路;
- 8.吸入管路的摩擦损失过大----更换吸入管路;
- 9.叶轮堵塞----清理堵塞物;

- 10.泵转速过高----选择适当转速;
- 11.泵转速过低----选择适当转速;
- 12.旋转方向错误----调整电机旋向或改用旋向相反的电机;
- 13.仪表未校准----使用前校准所用仪表;
- 14.叶轮实际直径小于规定直径----更换较大直径的叶轮;
- 15.叶轮实际直径大于规定直径----车削叶轮直径至规定值或更换较小直径叶轮;
- 16.在旁通管路及出口阀门关闭的情况下运行泵----采用正确的操作方式运行泵;
- 17.泵在低于规定的最小流量下运行----停止错误操作,在规定的流量运行;
- 18.在超过规定的最大流量下运行----在规定的最大流量以下运行;
- 19.内部配合零件间工作间隙过大----更换易损件;
- 20.叶轮内存在杂质----清除叶轮内杂质;
- 21.泵与电机轴不对中----调节联轴器使其对中;
- 22.基础刚性不足----采取措施增强基础刚性;
- 23.地脚螺栓松动----把紧地脚螺栓;
- 24.泵或电机与底座把紧螺栓松动----把紧螺栓;
- 25.底座灌浆不充分----重新灌浆;
- 26.作用在泵上的管路载荷超过规定值----采取措施调整作用在泵上的管路载荷;
- 27.泵主要配合面与泵轴中心不垂直----重新装配,保证安装面与轴中心线垂直;
- 28.泵轴弯曲变形----更换泵轴;
- 29.转子平衡精度未达到规定要求----重新拆装,按要求对转子进行动平衡试验;
- 30.轴上零部件未锁紧----锁紧轴上部件;
- 31.轴承磨损,导致轴偏心运转----更换轴承;
- 32.泵和基础底座或管路间发生共振----改变自然频率以避免发生共振;
- 33.转动与静止部件发生摩擦----重新检查安装,保证转动与静止部件间的间隙;
- 34.硬质颗粒进入运行间隙----清除硬质颗粒;
- 35.密封冲洗管路堵塞----拆卸后进行清理;
- 36.机械密封安装不正确----重新安装机械密封;
- 37.由于内部间隙过分磨损而引起的过大的轴向推力----更换磨损部件;
- 38.润滑脂或油的等级不正确----选用适合的润滑脂和润滑油;
- 39.滚动轴承箱润滑脂或油过量----排出过量的润滑油和润滑脂,按要求添加;
- 40.缺乏润滑----添加适量的润滑油或润滑脂;
- 41.滚动轴承安装不正确----拆卸后重新正确安装轴承;
- 42.杂质进入轴承----清理轴承或更换新轴承;
- 43.润滑油/脂受到污染----更换新的润滑油/脂。

9. 零部件

注意! 我们建议，水泵的维护和维修只能由威乐公司有资质的人员负责。

- 所有零部件只能由威乐公司提供。
- 只能使用威乐公司提供的零部件，确保水泵/水泵系统无故障运行。自行改装或非标准零部件的使用，须经制造商同意，使用原始备件将确保安全。使用其它零件，制造商将不承担由此引起的任何后果和责任。
- 订购零部件时请参考
 - 水泵和电机铭牌；
 - 零部件名称（见零部件清单）；
 - 机械密封部件编号（图 11、图 12 和图 13）
 - 需标识零部件编号。

9.1 建议提供保留 2 年的零部件

9.1.1 NX 泵

编号	零部件名称	水泵数量						
		2	3	4	5	6 和 7	8 和 9	≥10
		零部件数量						
5	装配轴	1	1	2	2	2	3	30%
4	叶轮	1	1	1	2	2	3	30%
17	滚珠轴承	2	2	4	4	6	8	100%
15	轴承座	-	-	-	-	-	1	2
-	平垫片/O型圈	4	6	8	8	9	12	150%
6.3	机械密封	2	2	4	4	6	8	100%

9.1.2 NX-A泵、NX-B泵和NX-C泵

编码	零部件名称	水泵数量						
		2	3	4	5	6 和 7	8 和 9	≥10
		零部件数量						
4	密封环	2	2	4	4	6	8	100%
5	装配轴	1	1	2	2	2	3	30%
3	叶轮	1	1	1	2	2	3	30%
13	圆柱轴承	1	1	2	2	3	4	100%
19	滚珠轴承	2	2	4	4	6	8	100%
15	轴承支架	-	-	-	-	-	1	2
-	密封垫/密封圈	4	6	8	8	9	12	150%
6.7	机械密封	2	2	4	4	6	8	100%
21	油封(NX-A)/防尘盖(NX-B、NX-C)	2	2	4	4	6	8	100%

9.2 水泵结构图 (机械密封)

9.2.1 NX 泵 (图11)



图 11

9.2.2 NX-A泵 (图12)

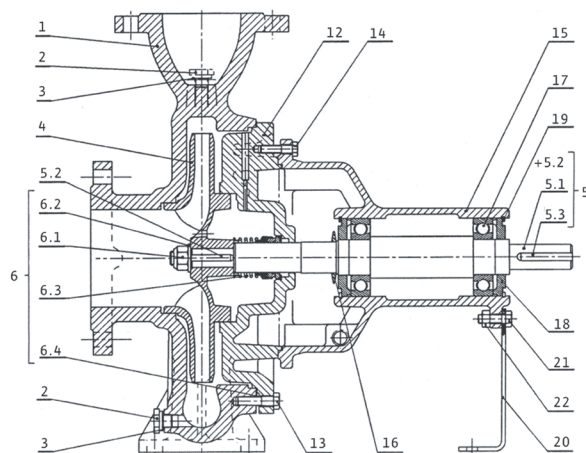

图 12

9.2.3 NX-B泵和NX-C泵 (图13)

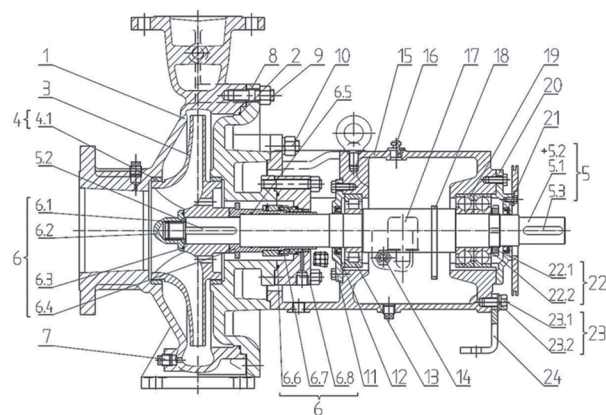

图 13

9.3 零部件清单

9.3.1 NX泵

零部件编号 (图11)	数量	零部件名称
1.	1	泵体
2.	2	螺塞
3.	2	密封垫片
4.	1	叶轮
5.	1	装配轴
5.1	1	轴
5.2	1	键
5.3	1	键
机械密封		
6.	1	机械密封装置
6.1	1	六角螺母
6.2	11	垫片
6.3	1	机械密封
6.4	1	壳体密封
12.	1	压盖
13.	12	六角头螺钉
14.	12	六角头螺钉
15.	1	轴承座
16.	1	润滑油圈
17.	2	滚珠轴承
18.	2	轴承盖
19.	2	卡簧
20.	1	支撑
21.	1	六角头螺钉
22.	1	六角螺母

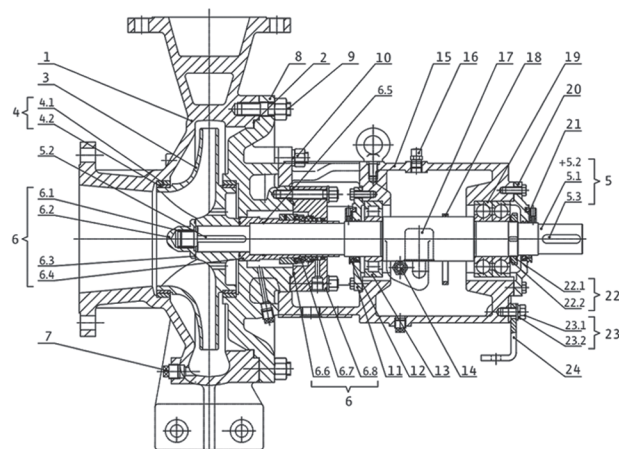
9.3.2 NX-A泵、NX-B泵和NX-C泵

零部件编号 (图12、图13)	数量	零部件名称
1.	1	泵体
2.	1	密封垫片
3.	1	叶轮
4.	2	密封环
4.1	2	泵体密封环
4.2	2	叶轮密封环 (仅NX-B、NX-C)
5.	1	装配轴
5.1	1	轴
5.2	1	键
5.3	1	键
6.	1	机械密封装置
6.1	1	钢丝螺套
6.2	1	叶轮螺母
6.3	2	密封圈
6.4	1	机封轴套
6.5	1	密封圈
6.6	1	密封圈
6.7	1	机械密封
6.8	1	机封压盖
7.	1	丝堵
8.	1	泵盖
9.	若干	螺柱
10.	若干	螺柱
11.	1	轴承压盖
12.	1	油封 (NX-A) / 防尘盖 (NX-B、NX-C)
13.	1	圆柱轴承
14.	1	可视油标
15.	1	轴承支架
16.	1	呼吸阀
18.	1	甩油环
19.	2	滚珠轴承
20.	1	轴承压盖
21.	1	油封 (NX-A) / 防尘盖 (NX-B、NX-C)
22.	1	轴承锁紧装置
22.1	1	圆螺母
22.2	1	止动垫圈
23.	1	调节螺栓
23.1	1	螺栓
23.2	1	垫圈



威乐中国总部
威乐（中国）水泵系统有限公司

Wilo China Ltd.

厂区地址(Plant Address): 北京市顺义区赵全营兆丰工业区兆丰二街10号 101300
No. 10 Zhaofeng 2nd Street, Zhaofeng Industrial Zone (Airport Industrial Zone C)
Zhaoquanying, Shunyi District, Beijing, China 101300

电话(Tel): 010-52347888

传真(Fax): 010-52347666

E-mail: wilo.info@wilo.com.cn

[Http://www.wilo.com.cn](http://www.wilo.com.cn)

销售热线: 800-810-8049

售后服务热线: 400-898-4886

威乐欧洲股份有限公司

WILO SE
Nortkirchenstraße 100
44263 Dortmund
Germany
T +49 231 4102-0
F +49 231 4102-7363
wilo@wilo.com
www.wilo.com

威乐公司不断改进和创新产品，若技术参数发生改变，以变更后数据为准。