

Pioneering for You

Submersible mixer EMU TR 221.36-6/8

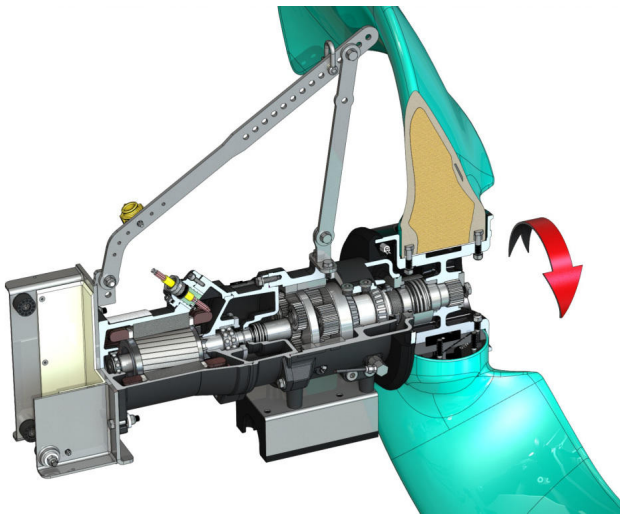

Unit

Power consumption at duty point $P_{1,1}$	1.88 hp
Max. thrust F	303.5 lbf
Thrust to power ratio	159 lbf/hp
Max. weight* m	440.9 lb
Explosion protection ATEX	optional
Explosion protection FM	optional
Protection class motor	IP68

Propeller

Propeller model	2-blade propeller with self-cleaning hub; clogging- and entwining-free
Nominal propeller diameter D_{nom}	82.7 in (*)
Propeller speed n	36 RPM
Transmission ratio	33.046

Filling quantities and types

Filling prechamber	Gear oil CLP220
Filling volume prechamber V	0.3 US gal
Filling gear chamber	Gear oil CLP220
Fill volume gear chamber V	0.2 US gal
Filling sealing chamber	White oil
Fill volume sealing chamber V	0.3 US gal

Motor/electronics

Motor type	T 17-6/8R (Ex)
Motor design	Submersible motor – surface-cooled
Mains connection	3~230 V, 60 Hz
Rated current I_N	9.00 A
Starting current – direct I_A	52.00 A
Starting current – star-delta I_A	18.00 A
Power consumption $P_{1 max}$	3.9 hp
Rated power P_2	2.7 hp
Speed original n	1080 RPM
Motor efficiency class	–
Efficiency η_M	70.0 %
Power factor $\cos \varphi_{100}$	0.80
Min. fluid temperature T_{min}	37 °F
Max. fluid temperature T_{max}	104 °F
Max. immersion depth	66 ft
Insulation class	H
Max. switching frequency t	15 rph
min. switching break t	3 min
Starting torque M	27.3 lbf ft
Moment of inertia	0.27 lb ft ²
Motor bearings	1 grooved ball bearing, 1 two-row inclined ball bearing

Materials

Motor housing	ASTM A48, Class No. 35
Static gaskets	FKM Fluoro rubber
Motor shaft	AISI 420
Seal, gear/sealing chamber	SiC/SiC, Q1Q1VGG
Gear housing	ASTM A48, Class No. 35
Planetary gear	AISI 5115
Hollow gear	Grade 60
Sun gear	AISI 5115
Output shaft	AISI 329
Seal, gear chamber/prechamber	FKM Fluoro rubber
Sealing chamber	ASTM A48, Class No. 35
Seal bushing	AISI 316Ti
Propeller hub	ASTM A536, Grade 60-40-18
Propeller	VE-GFRP

Gear

Gear construction type	m 2.0 as per DIN 780-1:1977-05 /P10 (ISO54:1996-12); sun and planetary gears case hardened and sanded, internal gear butt-jointed
Gear bearings	Six needle roller bearing (planetary), two tapered roller bearings (output shaft adjustable type), gearing permanently fixed
Service life L_{h10}	100,000 operating hours, ISO 281:2007-02

*maximum weight including accessories

Subject to change without prior notice.