

Pioneering for You

Submersible mixer EMU TR 221.25-8/8

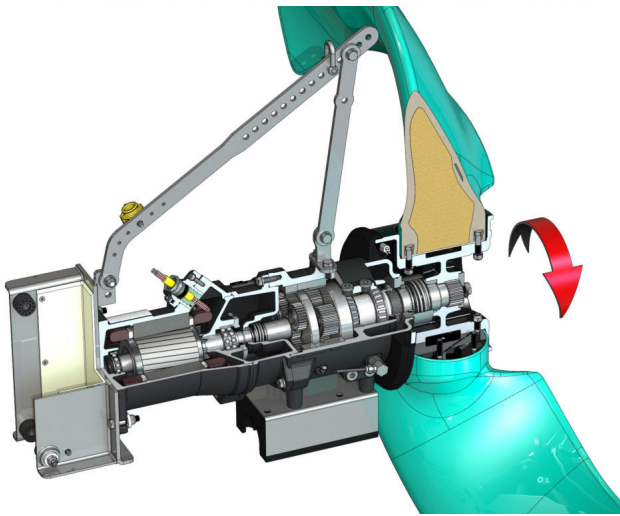

Unit

| | |
|---|------------|
| Power consumption at duty point $P_{1,1}$ | 1.07 hp |
| Max. thrust F | 146.1 lbf |
| Thrust to power ratio | 134 lbf/hp |
| Max. weight* m | 440.9 lb |
| Explosion protection ATEX ATEX | optional |
| Explosion protection FM FM | optional |
| Protection class motor | IP68 |

Propeller

| | |
|--------------------------------------|--|
| Propeller model | 2-blade propeller with self-cleaning hub; clogging- and entwining-free |
| Nominal propeller diameter D_{nom} | 82.7 in (*) |
| Propeller speed n | 25 RPM |
| Transmission ratio | 34.658 |

Filling quantities and types

| | |
|---------------------------------|-----------------|
| Filling prechamber | Gear oil CLP220 |
| Filling volume prechamber V | 0.3 US gal |
| Filling gear chamber | Gear oil CLP220 |
| Fill volume gear chamber V | 0.2 US gal |
| Filling sealing chamber | White oil |
| Fill volume sealing chamber V | 0.3 US gal |

Motor/electronics

| | |
|-------------------------------------|---|
| Motor type | T 17-8/8R (Ex) |
| Motor design | Submersible motor – surface-cooled |
| Mains connection | 3~230 V, 60 Hz |
| Rated current I_N | 7.20 A |
| Starting current – direct I_A | 36.00 A |
| Starting current – star-delta I_A | 12.00 A |
| Power consumption $P_{1 max}$ | 2.7 hp |
| Rated power P_2 | 1.7 hp |
| Speed original n | 840 RPM |
| Motor efficiency class | – |
| Efficiency η_M | 65.0 % |
| Power factor $\cos \varphi$ | 0.70 |
| Min. fluid temperature T_{min} | 37 °F |
| Max. fluid temperature T_{max} | 104 °F |
| Max. immersion depth | 66 ft |
| Insulation class | H |
| Max. switching frequency t | 15 rph |
| min. switching break t | 3 min |
| Starting torque M | 22.1 lbf ft |
| Moment of inertia | 0.27 lb ft ² |
| Motor bearings | 1 grooved ball bearing, 1 two-row inclined ball bearing |

Materials

| | |
|-------------------------------|------------------------|
| Motor housing | ASTM A48, Class No. 35 |
| Static gaskets | FKM Fluoro rubber |
| Motor shaft | AISI 420 |
| Seal, gear/sealing chamber | SiC/SiC, Q1Q1VGG |
| Gear housing | ASTM A48, Class No. 35 |
| Planetary gear | AISI 5115 |
| Hollow gear | Grade 60 |
| Sun gear | AISI 5115 |
| Output shaft | AISI 329 |
| Seal, gear chamber/prechamber | FKM Fluoro rubber |
| Sealing chamber | ASTM A48, Class No. 35 |
| Seal bushing | AISI 316Ti |
| Propeller hub | 60-40-15 |
| Propeller | VE-GFRP |

Gear

| | |
|------------------------|---|
| Gear construction type | m 2.0 as per DIN 780-1:1977-05 /P10 (ISO54:1996-12); sun and planetary gears case hardened and sanded, internal gear butt-jointed |
| Gear bearings | Six needle roller bearing (planetary), two tapered roller bearings (output shaft adjustable type), gearing permanently fixed |
| Service life L_{h10} | 100,000 operating hours, ISO 281:2007-02 |

*maximum weight including accessories