

Abmessungen für Tauchmotorrührwerk TR 30-1

Dimensions of Submersible mixer
Dimensions du circulateur immergé

TR 30-1
TR 30-1

wilo

Heimgartenstraße 1-3 D-95030 Hof/Saale
Telefon +49 9281 974-0 Fax +49 9281 96528
www.wilo.com E-Mail: info@wilo.com

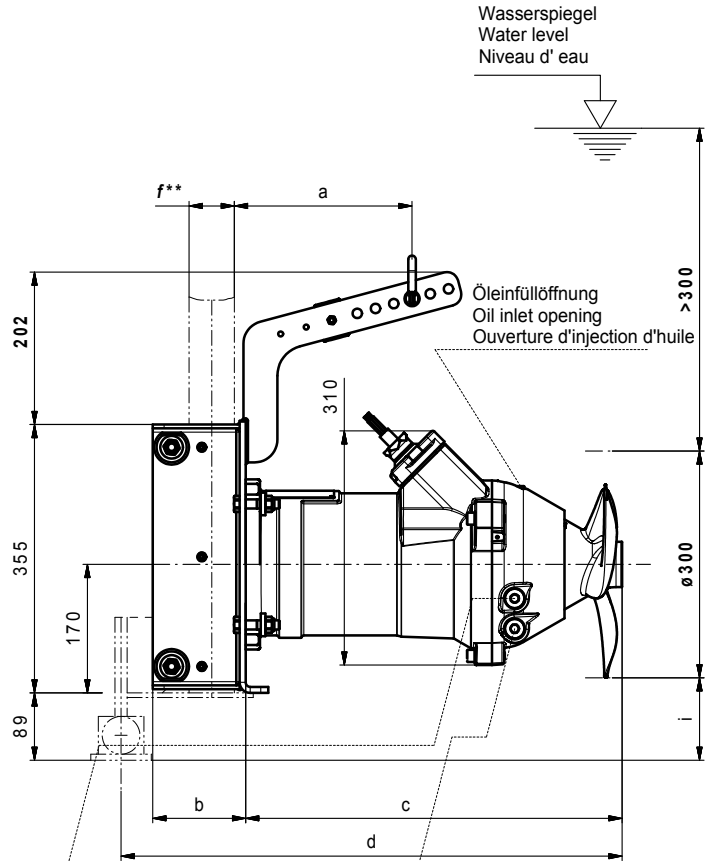
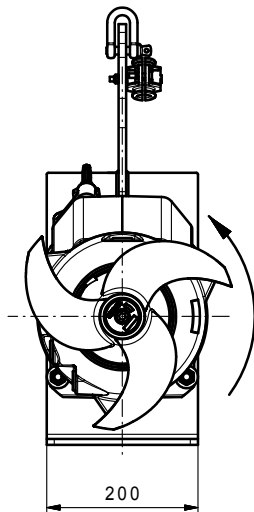
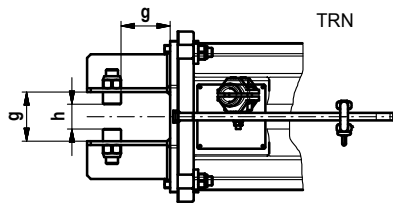

Einschraubmöglichkeit für Dichtraumkontrolle
Possibility for screwing in of the moisture probe
Possibilité pour visser le contrôle d'étanchéité

**) ab Beckentiefen > 6m ist mit dem Hersteller bezgl. der Gestängegröße Rücksprache zu halten!

From tank depths of 6m on please contact the manufacturer because of the guide pipe size!

A partir de 6m veuillez vous adresser au fabricant en ce qui concerne les dimensions des tubes de guidage!

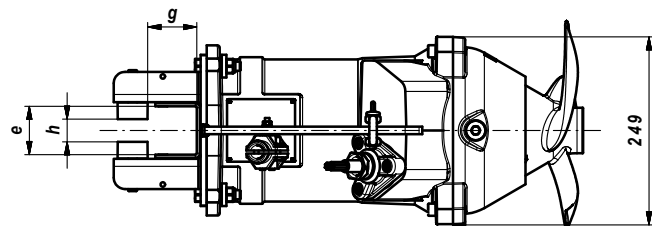

Motor / Motor type/	T17-.../8R		T17-.../12R		T17-.../16R	
Gestänge-Gr./ Size of pipes	f = 60x60	f = 80x80	f = 60x60	f = 80x80	f = 60x60	f = 80x80
a	165/160 ¹⁾		165/160 ¹⁾		190/185 ¹⁾	
b	123	143	123	143	123	143
c	425	425	460	460	500	500
d	595	655	630	690	670	730
e	64	84	64	84	64	84
g	65	85	65	85	65	85
h	30/33 ¹⁾	50/53 ¹⁾	30/33 ¹⁾	50/53 ¹⁾	30/33 ¹⁾	50/53 ¹⁾
i	109	152	109	152	109	152
Gewicht / Weight /	max. 76 kg		max. 80 kg		max. 90 kg	

¹⁾ TRN-Rahmen
TRN-Frame
TRN-Bâti

Maßstab: 1:10 Technische Änderungen vorbehalten - Technical changes reserved - Modifications techniques réservées

Datum: 10.01.18 Sp

Mb063.prt