

Abmessungen für Tauchmotorrührwerk TR 20-1

Dimensions of Submersible mixer

Dimensions du circulateur immergé

TR 20-1

TR 20-1

wilo

Heimgartenstraße 1-3 D-95030 Hof/Saale
 Telefon +49 9281 974-0 Fax +49 9281 96528
 www.wilo.com E-Mail: info@wilo.com

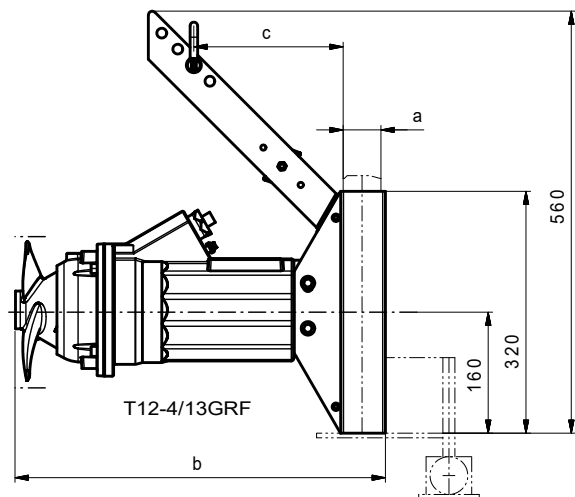
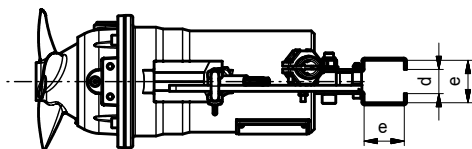
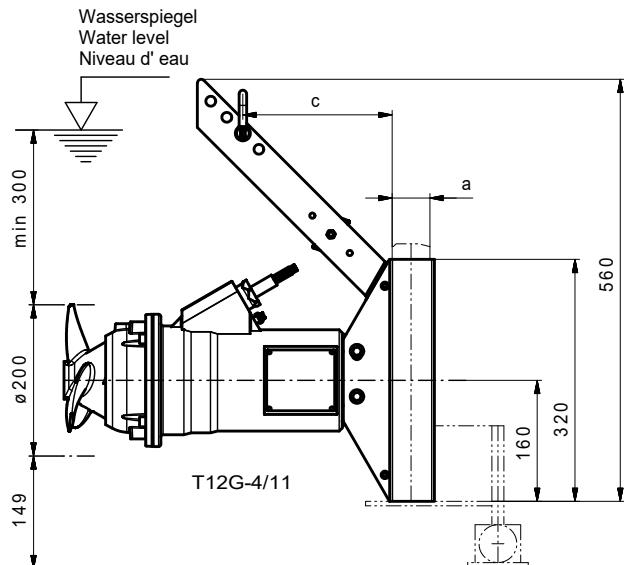
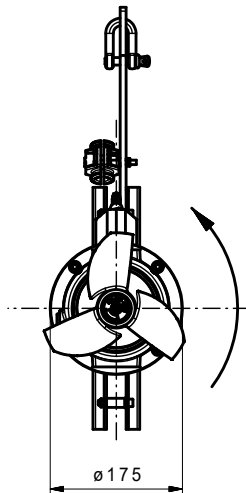

**) ab Beckentiefen > 6m ist mit dem Hersteller bezgl. der Gestängegröße Rücksprache zu halten!

From tank depths of 6m on please contact the manufacturer because of the guide pipe size!

A partir de 6m veuillez vous adresser au fabricant en ce qui concerne les dimensions des tubes de guidage!

Motor / Motor type/ Type de moteur	T12-4/13GRF	
	T12G-4/11	
Gestänge-Gr./ Size of pipes/ Dimension du tube	a= 50x50	a = 60x60
b	490	500
c	200	200
d	32	40
e	54	64
Gewicht / Weight / Poids	max. 40 kg	

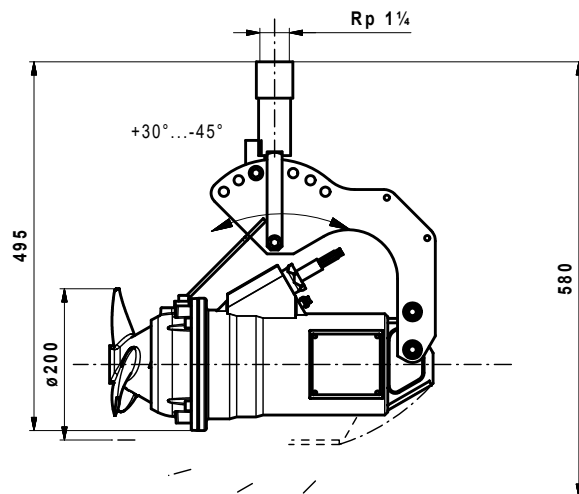

Maßstab: 1:10 Technische Änderungen vorbehalten - Technical changes reserved - Modifications techniques réservées

Datum: 2021-04-16 Rie

Mb061.prt