

Wastewater transport

Submersible pumps for sewage DN 50 to DN 80

Series description Wilo-Rexa PRO

Wilo-Rexa PRO

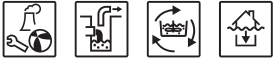

New!

Design

Submersible sewage pump for permanent operation, completely of cast iron

Model Numbers

Example:

Wilo-Rexa PRO V06NA-110/EAD1F2-T0015-646-O

PRO	Series name
V	Vortex impeller
06	Nominal diameter of the discharge port, e.g. ANSI 2.5 (DN 65)
N	Hydraulic version P = for wet well installation, suction port not drilled D = suction port drilled in accordance with DIN N = suction port drilled in accordance with ANSI (North American Standard)
A	Material version, hydraulics
110	Hydraulics intended use
E	Motor version E = glanded motor R = reduced-power motor
A	Material version, motor
D	with two independent mechanical seals
1	IE efficiency class, e.g. 1 = IE1 (according to IEC 60034-30)
F	Ex-rated X = ATEX F = FM
2	Number of poles
T	Mains connection version: M = 1~ T = 3~
0015	Value/10 = rated motor power P_2 in kW
6	Frequency = 60 Hz
46	Key for rated voltage
O	with bare cable end

Application

For pumping in permanent operation of:

- Wastewater and sewage
 - Wastewater containing faeces
 - Sludges up to maximum 8% dry matter (depending on the selected hydraulics)
- out of sumps and vessels in municipal and industrial applications as well as to domestic and site drainage.

Special features/product advantages

- Vortex impeller non-susceptible to clogging
- Seal by two mechanical shaft seals
- Ex-rated in accordance with FM and ATEX as standard
- Operation with frequency converter
- Optionally with installed external moisture probe for the oil barrier chamber
- Longitudinally watertight cable inlet
- Very smooth operation
- Simple installation via suspension unit or pump base
- Impeller trimmed to specific duty point

Technical data

- Standard power connection for 60 Hz: 3~230 V or 3~460 V
- Submerged operating mode: S1
- Partially submerged operating mode: S2-30 min; S3 25%
- Dry-pit operating mode: S2-30 min, S3 25%
- Protection class: IP 68
- Insulation class: F
- Max. fluid temperature: 37 - 104 °F (3 - 40°C), max. 140 °F (60°C) for 3 min
- Free passage: 2 / 2.5 / 3 in (50 / 65 / 80 mm)
- Max. immersion depth: 66 ft (20 m)

Materials

- Motor housing: ASTM A48 Class 35/40B (EN-GJL-250)
- Hydraulic housing: ASTM A48 Class 35/40B (EN-GJL-250)
- Impeller: ASTM A48 Class 35/40B (EN-GJL-250)
- Static seals: Nitrile (NBR)
- Sealing on pump side: SiC/SiC
- Sealing on motor side: C/MgSiO₄
- Shaft end: Stainless steel AISI 420 (1.4021)

Series description Wilo-Rexa PRO

Equipment/function

- Leakage detection for the motor compartment
- Winding temperature monitoring with bimetal sensor as standard or PTC sensor as an option
- Optionally with installed external sealing chamber control for the oil barrier chamber

Description/design

Submersible sewage pump as submersible monobloc unit for station-ary and portable wet well installation in permanent operation.

Hydraulics

The outlet flange on the discharge side is designed as horizontal connection. The maximum possible dry matter is 8 % (depending on the hydraulics) Vortex impellers are used as the impeller shape.

Motor

The motors available as glanded motors in three-phase version for the direct starting. There conduct heat directly to the surrounding fluid via the motor housing. Accordingly, these motors can operated completely submerged in continuous operation (S1) and partially submerged in short-term operation (S2) or intermittent operation (S3).

Furthermore the motors are equipped with the following monitoring devices:

- Leakage control for motor compartment
The leakage control signals water ingress into the motor compartment.
- Thermal motor control
The thermal motor control protects the motor windings against overheating. Bimetal sensors are used for this as standard. Optionally thermistor sensors can be fitted.

In addition the motor can be equipped with an external moisture probe for monitoring the oil barrier chamber. This signals if there is water ingress into the oil barrier chamber through the mechanical seal on the fluid side.

The connecting cable has bare cable ends as standard and is cast as longitudinally watertight. The cable length is made in fixed lengths up to 50 metres; from 50 metres as per customer request.

Seal

There is an oil barrier chamber between the motor and hydraulics. This is filled with medicinal white oil. The fluid-side and motor-side seals are provided by two mechanical seals which rotate independently of each other.

Options

- Thermistor temperature sensor
- Motor windings to insulation class "H"
- Special voltages, e.g. 208 V, 380 V, 575 V
- Static seals of Viton
- Motor-side seal in SiC/SiC
- Ceram coating C0 for housing and impeller against corrosion
- Impeller trimmed to specific duty point

Scope of delivery

- Submersible sewage pump with attached accessories (e.g. pump base, plug, switchgear, moisture probe)
- Cable type and length as requested
- Operating and maintenance manual

Accessories

- Suspension unit (guide rail system or portable base)
- Moisture probe
- Ceram coating
- Chains
- Switchgears, relays and plugs
- Fixation sets with anchor bolts

Commissioning

Operation in wet well installation with non-submerged motor:

It is possible to have the motor partially submerged for short periods if equipped with motor temperature monitoring with a temperature circuit, or with two temperature circuits when used in potentially explosive areas. The maximum running times with partially submerged motor at a maximum fluid temperature of 104 °F (40 °C) are 30 minutes for short-term operation (S2) and 5 minutes for intermittent operation (S3).

Dry-running protection:

The pump volute must always be submerged. In the case of fluctuating fluid levels, the system should shut down automatically once the minimum water submersion is reached. Please refer to the dimension drawings for this.

Horizontal installation:

Horizontal installation is **not** possible with these units!

Dry well installation:

Dry well installation is **not** possible with these units!

Wastewater transport

Submersible pumps for sewage DN 50 to DN 80

Series description Wilo-Rexa PRO

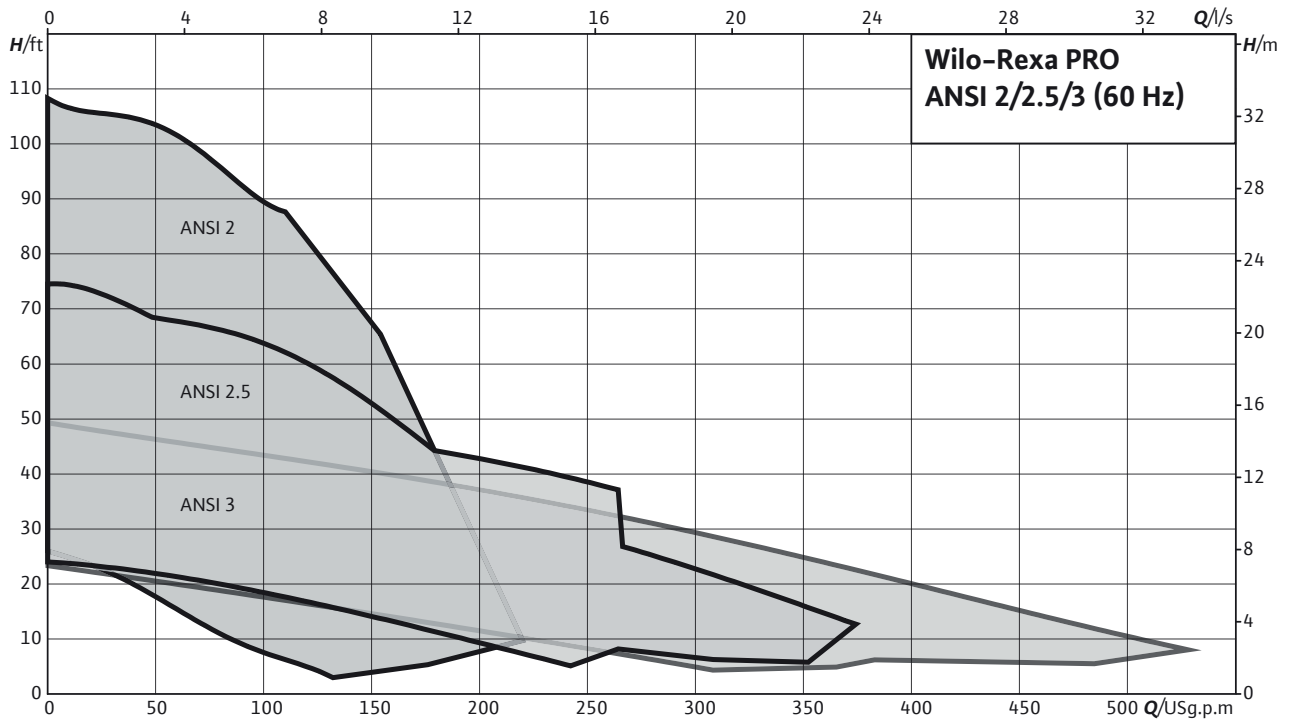

Pump curves, technical data Wilo-Rexa PRO V05..-12.. (3480 rpm)

Pump curves Wilo-Rexa PRO V05..-12.. - 60 Hz - 3480 rpm

Vortex impeller - Free ball passage: 2.0in (50 mm)

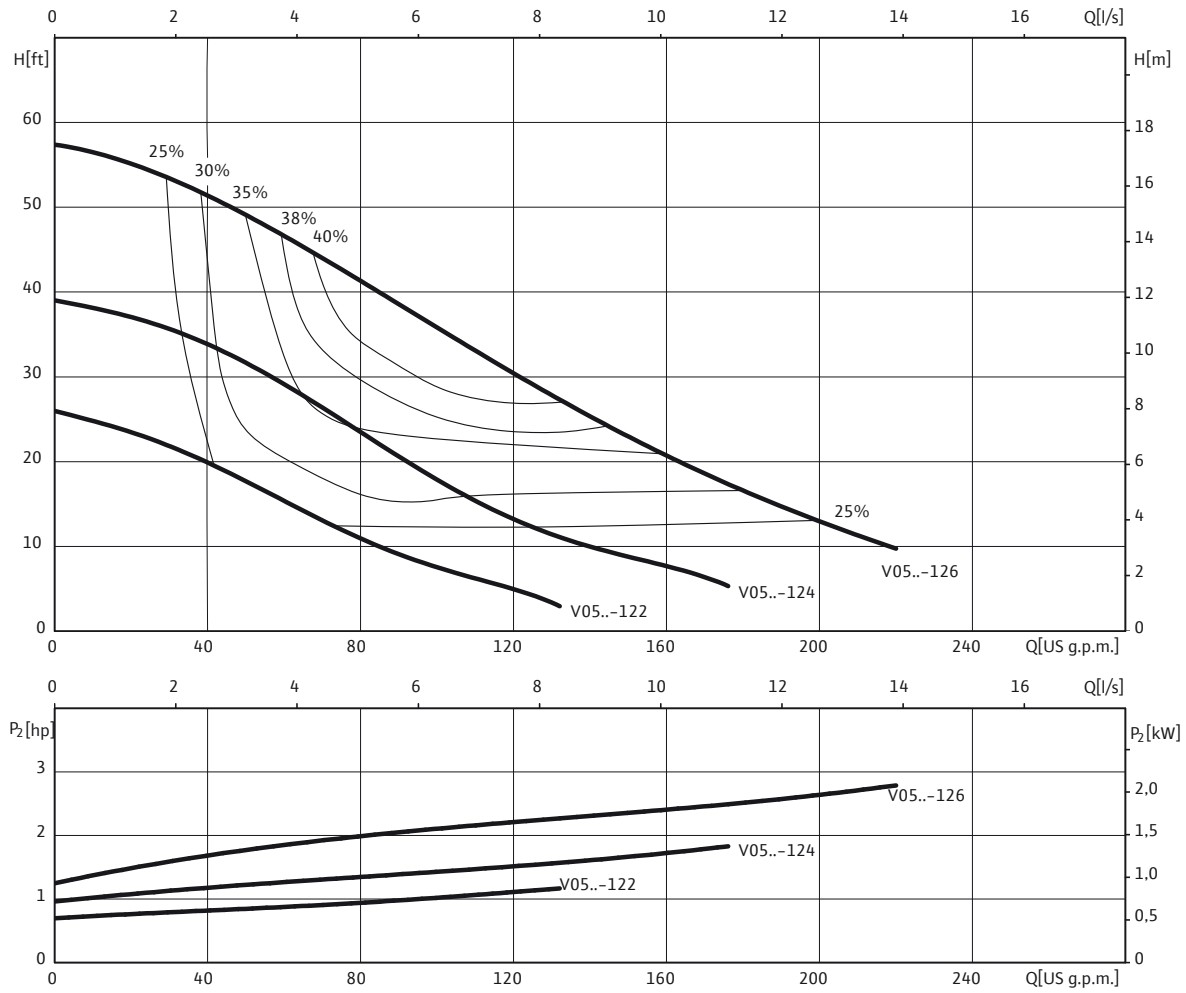

Hydraulic data

Wilo-Rexa...	Free ball passage		Type of impeller	Weight of hydraulic unit	
	in	mm		lbs	kg
PRO V05..-12..	2.0	50	Vortex impeller	29	13

Pump curves apply to 3~230 V or 460 V, 60 Hz, at nominal speed and a density of 1 kg/dm³. Pump curves according to ISO 9906, appendix A. The specified degrees of efficiency correspond to the hydraulic efficiency.

Wastewater transport

Submersible pumps for sewage DN 50 to DN 80

Pump curves, technical data Wilo-Rexa PRO V05..-12.. (3480 rpm)

Motor data

	Power connection	Full load amps	Starting current - direct	Rated motor power (per motor)		Maximum power consumption		Operating mode (immersed/non-immersed)	Motor weight		Dimensions	
				P_2		P_1					A	
				I_N	I_A	hp	kW		hp	kW	lbs	kg
P 13.1-08/EAD1F2-T	3~460 V, 60 Hz	2.25	22	1.48	1.10	1.93	1.44	S1/S2-30 min S3-25%	71	32	14 ¹¹ / ₁₆	373
P 13.1-08/EAD1F2-T	3~460 V, 60 Hz	2.8	21.5	2.01	1.50	2.57	1.92	S1/S2-30 min S3-25%	71	32	14 ¹¹ / ₁₆	373
P 13.1-10/EAD1F2-T	3~460 V, 60 Hz	4.5	33.5	3.35	2.50	4.16	3.10	S1/S2-30 min S3-25%	79	36	18 ¹ / ₁₆	458
P 13.1-08/EAD1F2-T	3~230 V, 60 Hz	4.5	44	1.48	1.10	1.93	1.44	S1/S2-30 min S3-25%	71	32	14 ¹¹ / ₁₆	373
P 13.1-08/EAD1F2-T	3~230 V, 60 Hz	5.6	43.5	2.01	1.50	2.57	1.92	S1/S2-30 min S3-25%	71	32	14 ¹¹ / ₁₆	373
P 13.1-10/EAD1F2-T	3~230 V, 60 Hz	9	68	3.35	2.50	4.16	3.10	S1/S2-30 min S3-25%	79	36	18 ¹ / ₁₆	458

P_1 refers to the maximum power consumption. All of the data applies to 3~460 V, 60 Hz and a density of 1 kg/dm³.
Voltage tolerance +/- 10 % (specifications according to DIN EN 60034)

Materials: Seals

	Static seal	Mechanical seal	Sealing on motor side
P 13...	Nitrile	SiC/SiC	Carbon/steatite

Equipment/function

	Explosion protection according to		Motor temperature monitoring	Motor leakage detection	Sealing chamber leakage detection	Leakage chamber leakage detection	Bearing temperature monitoring	Terminal chamber leakage detection
	ATEX	FM						
P 13...	-	•	•	•	○	-	-	-

• = available, - = not available, ○ = optional

Dimensions Wilo-Rexa PRO V05..-12.. (3480 rpm)

Dimension drawing Wilo-Rexa PRO V05 - stationary wet well installation

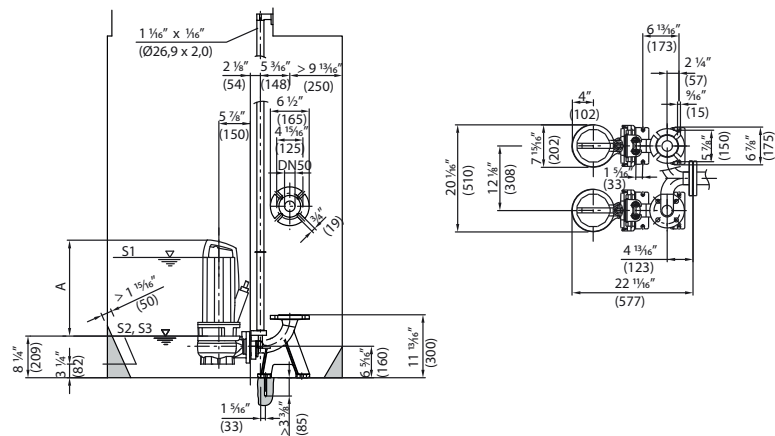

Dimension drawing Wilo-Rexa PRO V05 - portable wet well installation

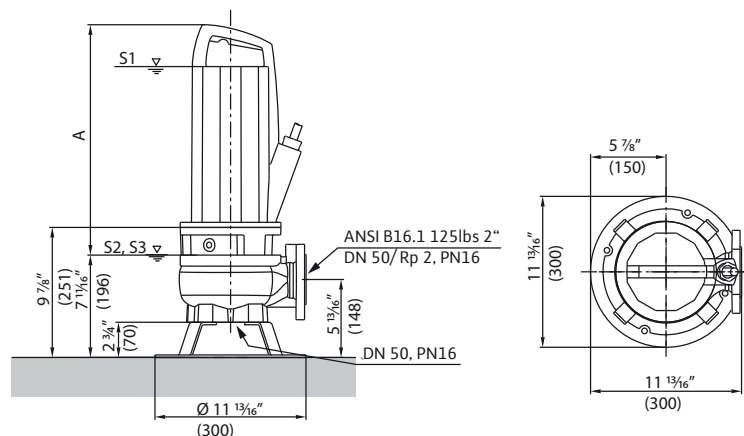

Wastewater transport

Submersible pumps for sewage DN 50 to DN 80

Pump curves, technical data Wilo-Rexa PRO V05..-22.. (3480 rpm)

Pump curves Wilo-Rexa PRO V05..-22.. - 60 Hz - 3480 rpm

Vortex impeller - Free ball passage: 2.0in (50 mm)

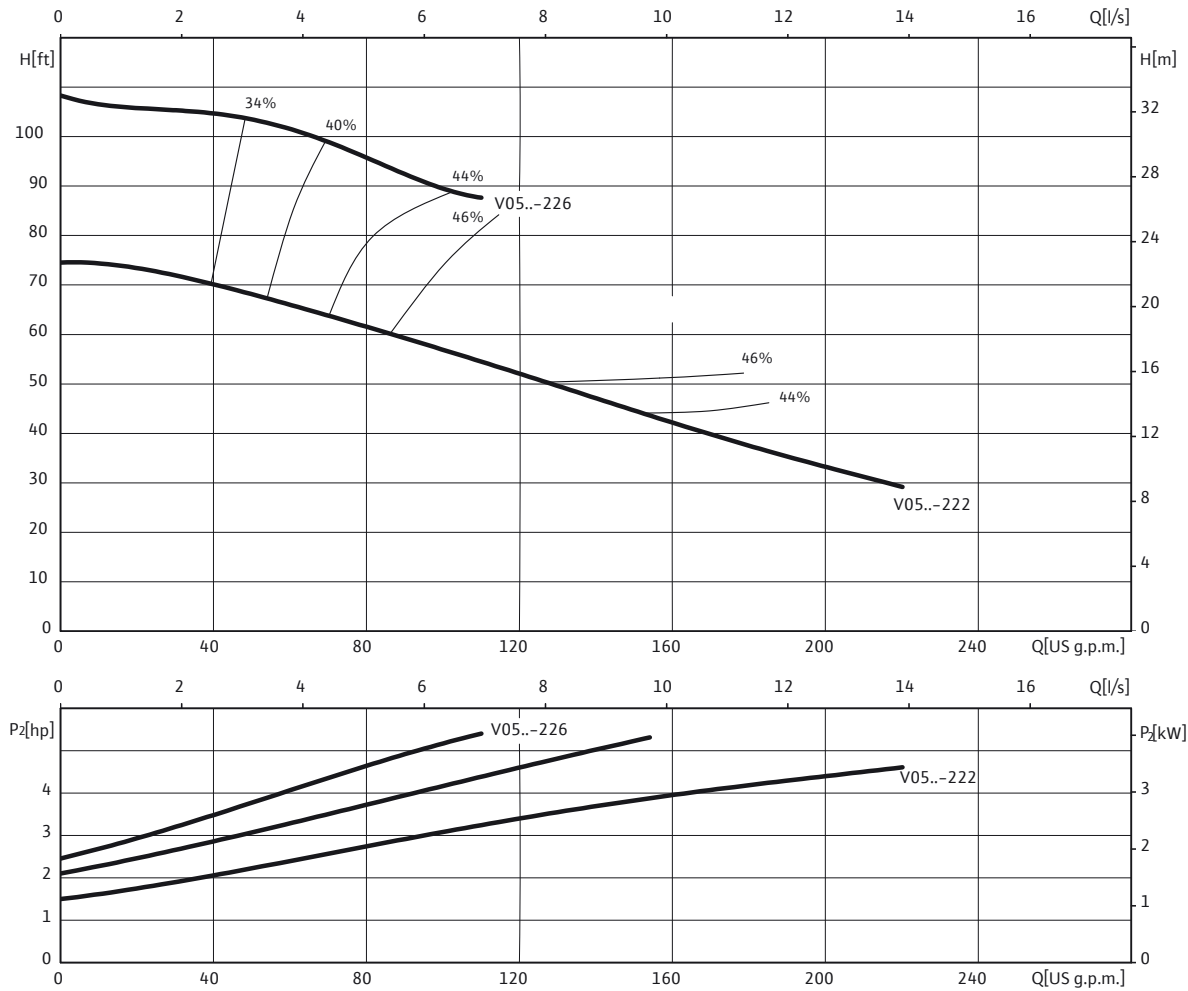

Hydraulic data

Wilo-Rexa...	Free ball passage		Type of impeller	Weight of hydraulic unit	
	in	mm		lbs	kg
PRO V05..-22..	2.0	50	Vortex impeller	31	14

Pump curves apply to 3~230 V or 460 V, 60 Hz, at nominal speed and a density of 1 kg/dm³. Pump curves according to ISO 9906, appendix A. The specified degrees of efficiency correspond to the hydraulic efficiency.

Wastewater transport

Submersible pumps for sewage DN 50 to DN 80



Pump curves, technical data Wilo-Rexa PRO V05..-22.. (3480 rpm)

Motor data

	Power connection	Full load amps	Starting current - direct	Rated motor power (per motor)		Maximum power consumption		Operating mode (immersed/non-immersed)	Motor weight		Dimensions	
				P_2		P_1			A		A	
				I_N	I_A	hp	kW		hp	kW	lbs	kg
P 13.1-10/EAD1F2-T	3~460 V, 60 Hz	4.5	33.5	3.35	2.50	4.16	3.10	S1/S2-30 min S3-25%	79	36	18 ¹ / ₁₆	458
P 13.1-15/EAD1F2-T	3~460 V, 60 Hz	6.7	71	5.23	3.90	6.24	4.65	S1/S2-30 min S3-25%	88	40	18 ¹ / ₁₆	458
P 13.1-10/EAD1F2-T	3~230 V, 60 Hz	9	68	3.35	2.50	4.16	3.10	S1/S2-30 min S3-25%	79	36	18 ¹ / ₁₆	458
P 13.1-15/EAD1F2-T	3~230 V, 60 Hz	13.4	143	5.23	3.90	6.24	4.65	S1/S2-30 min S3-25%	88	40	18 ¹ / ₁₆	458

P_1 refers to the maximum power consumption. All of the data applies to 3~460 V, 60 Hz and a density of 1 kg/dm³.
Voltage tolerance +/- 10 % (specifications according to DIN EN 60034)

Materials: Seals

	Static seal	Mechanical seal	Sealing on motor side
P 13...	Nitrile	SiC/SiC	Carbon/steatite

Equipment/function

	Explosion protection according to		Motor temperature monitoring	Motor leakage detection	Sealing chamber leakage detection	Leakage chamber leakage detection	Bearing temperature monitoring	Terminal chamber leakage detection
	ATEX	FM						
P 13...	-	•	•	•	o	-	-	-

• = available, - = not available, o = optional

Wastewater transport

Submersible pumps for sewage DN 50 to DN 80

Dimensions Wilo-Rexa PRO V05..-22.. (3480 rpm)

Dimension drawing Wilo-Rexa PRO V05 – stationary wet well installation

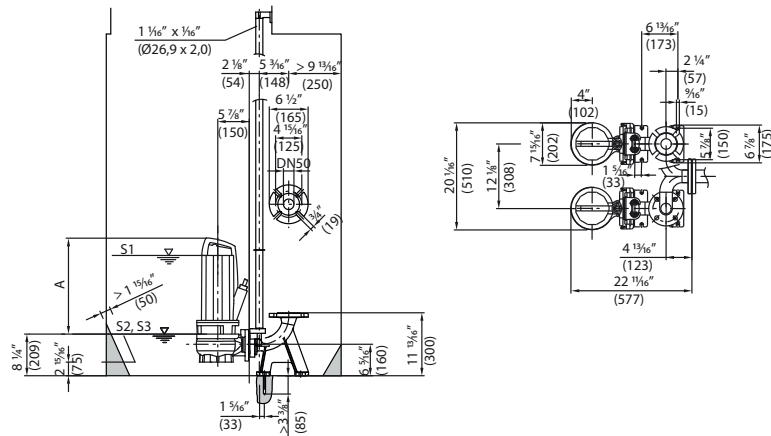

Dimension drawing Wilo-Rexa PRO V05 – portable wet well installation

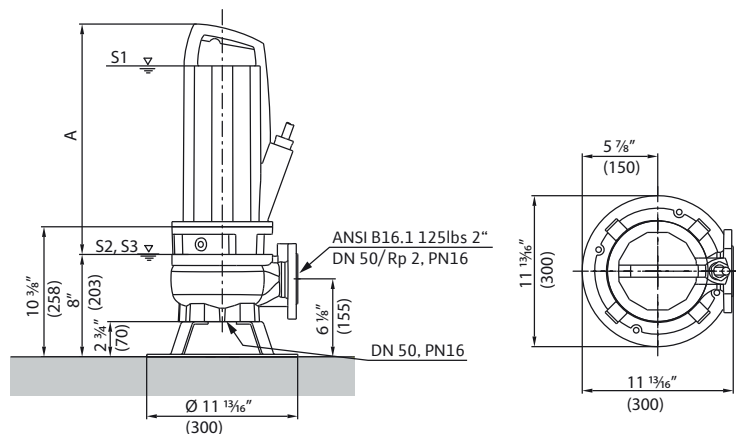

Wastewater transport

Submersible pumps for sewage DN 50 to DN 80

Pump curves, technical data Wilo-Rexa PRO V06..-62.. (1740 rpm)

Pump curves Wilo-Rexa PRO V06..-62.. – 60 Hz – 1740 rpm

Vortex impeller – Free ball passage: 2.6in (65 mm)

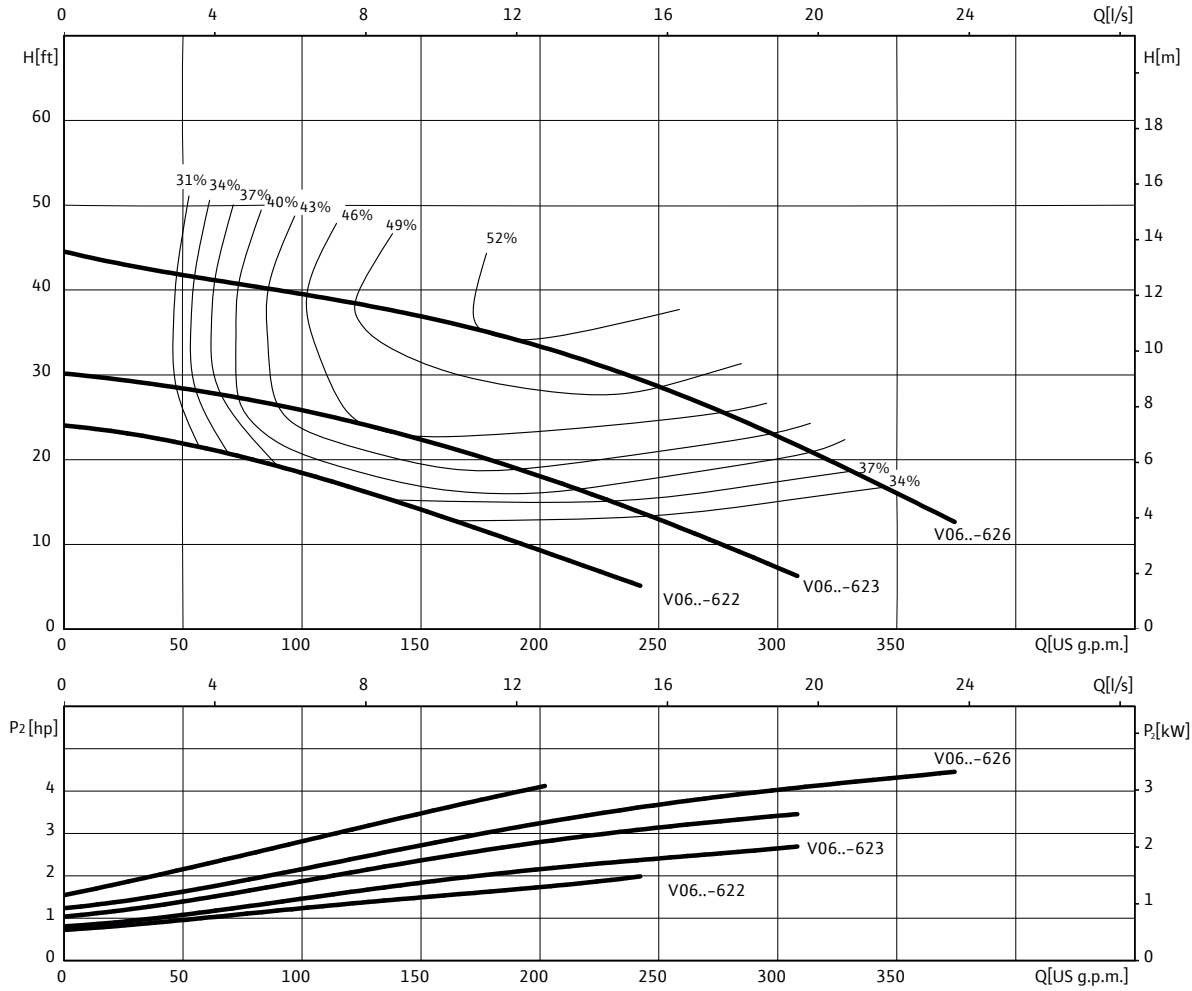

Hydraulic data

Wilo-Rexa...	Free ball passage		Type of impeller	Weight of hydraulic unit	
	in	mm		lbs	kg
PRO V06..-62..	2.6	65	Vortex impeller	44	20

Pump curves apply to 3~230 V or 460 V, 60 Hz, at nominal speed and a density of 1 kg/dm³. Pump curves according to ISO 9906, appendix A. The specified degrees of efficiency correspond to the hydraulic efficiency.

Wastewater transport

Submersible pumps for sewage DN 50 to DN 80



Pump curves, technical data Wilo-Rexa PRO V06..-62.. (1740 rpm)

Motor data

	Power connection	Full load amps	Starting current - direct	Rated motor power (per motor)		Maximum power consumption		Operating mode (immersed/non-immersed)	Motor weight		Dimensions	
				P_2		P_1			A		A	
				I_N	I_A	hp	kW		hp	kW	lbs	kg
P 13.2-10/EAD1F4-T	3~460 V, 60 Hz	2.8	26.5	1.48	1.10	1.94	1.45	S1/S2-30 min S3-25%	88	40	18 ¹ / ₈	460
P 13.2-10/EAD1F4-T	3~460 V, 60 Hz	3.3	26.5	2.01	1.50	2.59	1.93	S1/S2-30 min S3-25%	88	40	18 ¹ / ₈	460
P 13.2-13/EAD1F4-T	3~460 V, 60 Hz	5	36.5	3.35	2.50	4.22	3.15	S1/S2-30 min S3-25%	93	42	18 ¹ / ₈	460
P 13.2-16/EAD0F4-T	3~460 V, 60 Hz	6.9	55	4.63	3.45	5.77	4.30	S1/S2-30 min S3-25%	97	44	18 ¹ / ₈	460
P 13.2-10/EAD1F4-T	3~230 V, 60 Hz	5.6	53	1.48	1.10	1.94	1.45	S1/S2-30 min S3-25%	88	40	18 ¹ / ₈	460
P 13.2-10/EAD1F4-T	3~230 V, 60 Hz	6.6	54	2.01	1.50	2.59	1.93	S1/S2-30 min S3-25%	88	40	18 ¹ / ₈	460
P 13.2-13/EAD1F4-T	3~230 V, 60 Hz	10	72	3.35	2.50	4.22	3.15	S1/S2-30 min S3-25%	93	42	18 ¹ / ₈	460
P 13.2-16/EAD0F4-T	3~230 V, 60 Hz	13.8	110	4.63	3.45	5.77	4.30	S1/S2-30 min S3-25%	93	42	18 ¹ / ₈	460

P_1 refers to the maximum power consumption. All of the data applies to 3~460 V, 60 Hz and a density of 1 kg/dm³.
Voltage tolerance +/- 10 % (specifications according to DIN EN 60034)

Materials: Seals

	Static seal	Mechanical seal	Sealing on motor side
P 13...	Nitrile	SiC/SiC	Carbon/steatite

Equipment/function

	Explosion protection according to		Motor temperature monitoring	Motor leakage detection	Sealing chamber leakage detection	Leakage chamber leakage detection	Bearing temperature monitoring	Terminal chamber leakage detection
	ATEX	FM						
P 13...	-	•	•	•	o	-	-	-

• = available, - = not available, o = optional

Wastewater transport

Submersible pumps for sewage DN 50 to DN 80

Dimensions Wilo-Rexa PRO V06..-62.. (1740 rpm)

Dimension drawing Wilo-Rexa PRO V06 – stationary wet well installation for DN 65

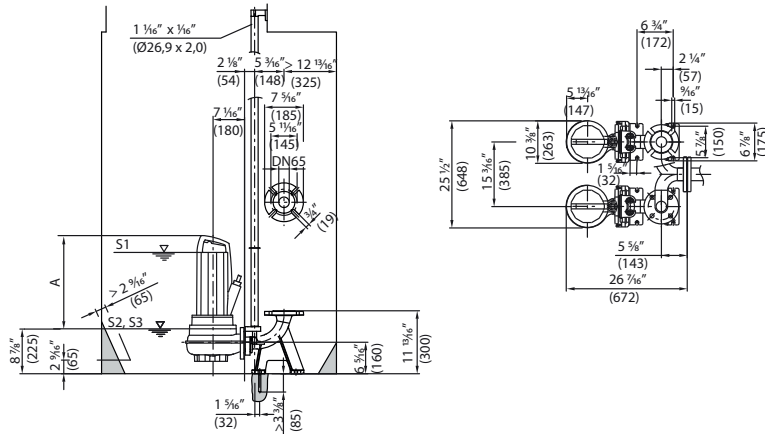

Dimension drawing Wilo-Rexa PRO V06 – stationary wet well installation for DN 80

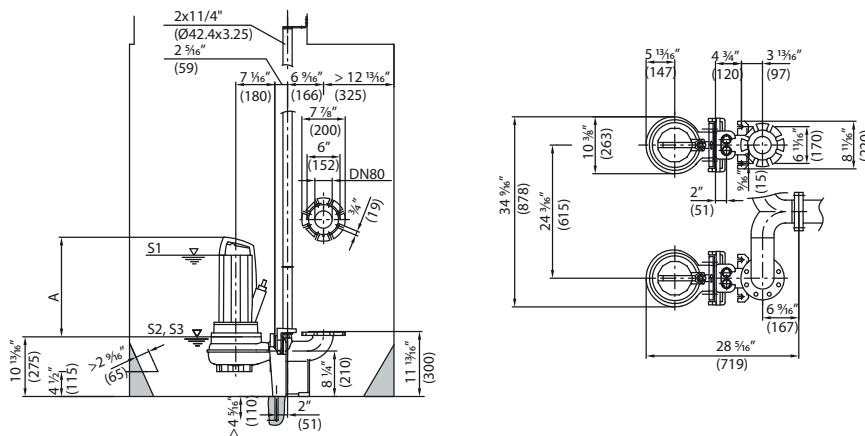

Dimension drawing Wilo-Rexa PRO V06 – portable wet well installation

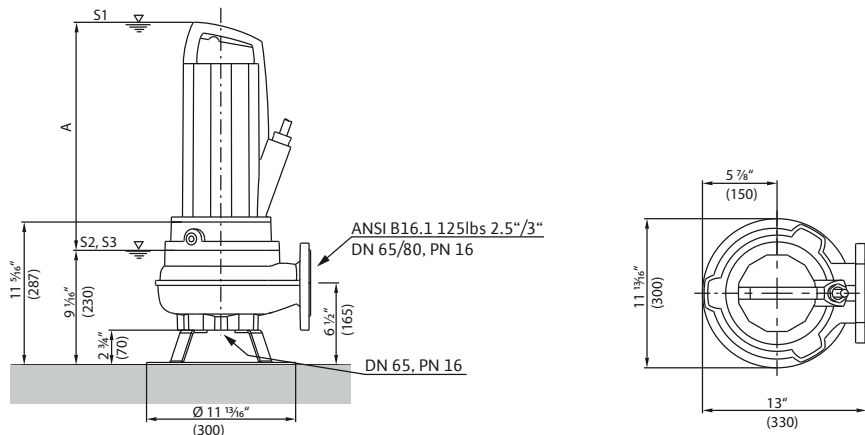

Pump curves, technical data Wilo-Rexa PRO V08..-42.. (1740 rpm)

Pump curves Wilo-Rexa PRO V08..-42.. - 60 Hz - 1740 rpm

Vortex impeller - Free ball passage: 3.1in (80 mm)

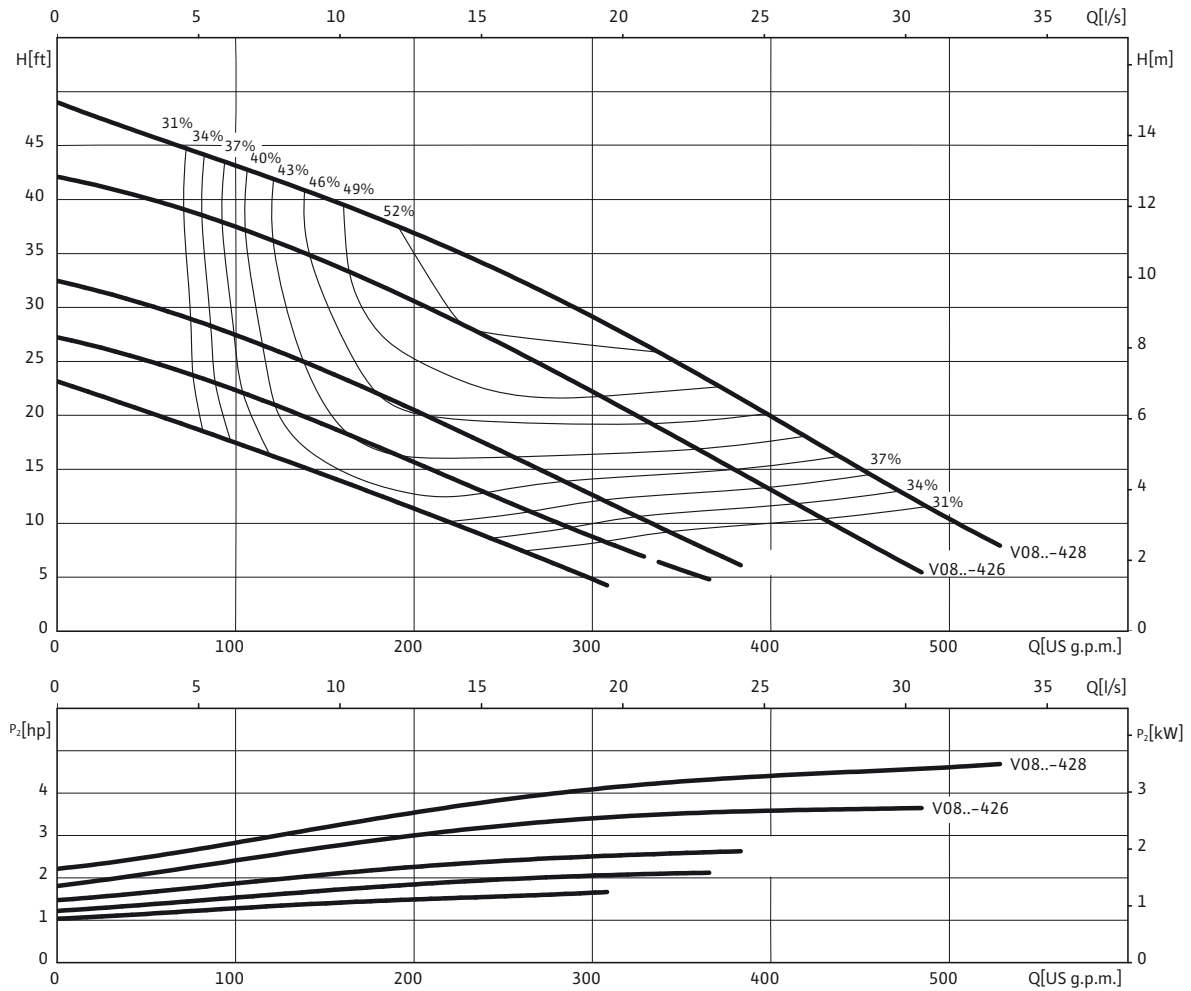

Hydraulic data

Wilo-Rexa...	Free ball passage		Type of impeller	Weight of hydraulic unit	
	in	mm		lbs	kg
PRO V08..-42..	3.1	80	Vortex impeller	62	28

Pump curves apply to 3~230 V or 460 V, 60 Hz, at nominal speed and a density of 1 kg/dm³. Pump curves according to ISO 9906, appendix A. The specified degrees of efficiency correspond to the hydraulic efficiency.

Wastewater transport

Submersible pumps for sewage DN 50 to DN 80

Pump curves, technical data Wilo-Rexa PRO V08..-42.. (1740 rpm)

Motor data

	Power connection	Full load amps	Starting current - direct	Rated motor power (per motor)		Maximum power consumption		Operating mode (immersed/non-immersed)	Motor weight		Dimensions	
				P_2		P_1					A	
				I_N	I_A	hp	kW		hp	kW	lbs	kg
P 13.2-10/EAD1F4-T	3~460 V, 60 Hz	2.8	26.5	1.48	1.10	1.94	1.45	S1/S2-30 min S3-25%	88	40	18 ¹ / ₈	460
P 13.2-10/EAD1F4-T	3~460 V, 60 Hz	3.3	26.5	2.01	1.50	2.59	1.93	S1/S2-30 min S3-25%	88	40	18 ¹ / ₈	460
P 13.2-13/EAD1F4-T	3~460 V, 60 Hz	5	36.5	3.35	2.50	4.22	3.15	S1/S2-30 min S3-25%	93	42	18 ¹ / ₈	460
P 13.2-16/EAD0F4-T	3~460 V, 60 Hz	6.9	55	4.63	3.45	5.77	4.30	S1/S2-30 min S3-25%	97	44	18 ¹ / ₈	460
P 13.2-10/EAD1F4-T	3~230 V, 60 Hz	5.6	53	1.48	1.10	1.94	1.45	S1/S2-30 min S3-25%	88	40	18 ¹ / ₈	460
P 13.2-10/EAD1F4-T	3~230 V, 60 Hz	6.6	54	2.01	1.50	2.59	1.93	S1/S2-30 min S3-25%	88	40	18 ¹ / ₈	460
P 13.2-13/EAD1F4-T	3~230 V, 60 Hz	10	72	3.35	2.50	4.22	3.15	S1/S2-30 min S3-25%	93	42	18 ¹ / ₈	460
P 13.2-16/EAD0F4-T	3~230 V, 60 Hz	13.8	110	4.63	3.45	5.77	4.30	S1/S2-30 min S3-25%	93	42	18 ¹ / ₈	460

P_1 refers to the maximum power consumption. All of the data applies to 3~460 V, 60 Hz and a density of 1 kg/dm³. Voltage tolerance +/- 10 % (specifications according to DIN EN 60034)

Materials: Seals

	Static seal	Mechanical seal	Sealing on motor side
P 13...	Nitrile	SiC/SiC	Carbon/steatite

Equipment/function

	Explosion protection according to		Motor temperature monitoring	Motor leakage detection	Sealing chamber leakage detection	Leakage chamber leakage detection	Bearing temperature monitoring	Terminal chamber leakage detection
	ATEX	FM						
P 13...	-	•	•	•	○	-	-	-

• = available, - = not available, ○ = optional

Wastewater transport

Submersible pumps for sewage DN 50 to DN 80



Dimensions Wilo-Rexa PRO V08..-42.. (1740 rpm)

Dimension drawing Wilo-Rexa PRO V08 - stationary wet well installation

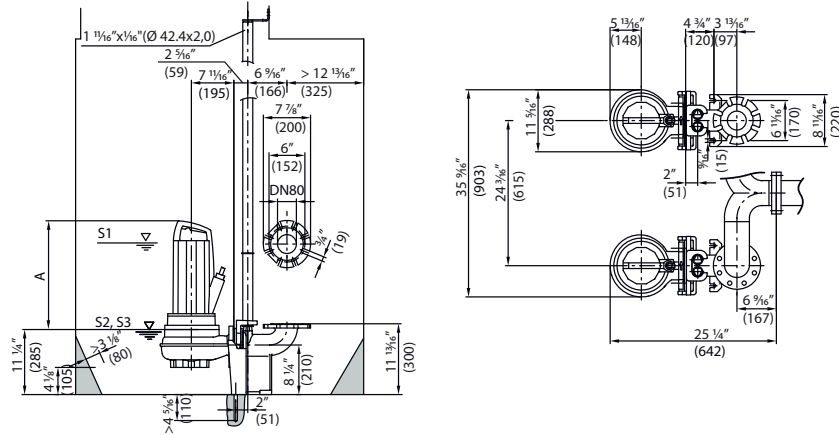

Dimension drawing Wilo-Rexa PRO V08 - portable wet well installation

