

## Wilo-NLB

**GB** Installation and operating instructions

**中** 安装及操作维护说明书

# CONTENTS

1.	General .....	2
1.1	Uses .....	2
1.2	Product data .....	2
1.2.1	Rating plate .....	2
1.2.2	Connection and electrical data .....	2
2.	Safety .....	3
2.1	Danger symbols used in these operating instructions.....	3
2.2	Staff training .....	3
2.3	Risks incurred by failure to comply with the safety precautions .....	3
2.4	Safety precautions for the operator.....	3
2.5	Safety information for inspection and assembly .....	3
2.6	Unauthorized modification and manufacture of spare parts .....	3
2.7	Unauthorized operating methods .....	3
3.	Transport and storage .....	4
3.1	Transport .....	4
3.1.1	General recommendations .....	4
3.1.2	Fitting the carrying cables .....	4
3.2	Storage.....	4
4.	Product and accessory description .....	4
4.1	Pump description .....	4
4.2	Products delivered .....	4
4.3	Accessories .....	4
4.4	Expected noise values as guideline .....	5
5.	Assembly/installation .....	5
5.1	Preparations .....	5
5.1.1	Unpacking and inspection .....	5
5.1.2	Site .....	5
5.1.3	Foundation.....	6
5.2	Installation.....	6
5.3	Connecting the pipes .....	7
5.4	Final inspection.....	8
5.5	Electrical connection.....	8
6.	Operation.....	9
6.1	Initial start-up .....	9
6.1.1	Switching on.....	9
6.1.2	Switching off .....	9
6.2	Operation .....	10
7.	Maintenance.....	10
7.1	General information .....	10
7.2	Routine maintenance .....	10
7.2.1	Bearing brackets with rolling bearings .....	10
7.2.2	Shaft seals .....	10
8.	Problems, Causes and Solution .....	11
9.	Spare parts .....	12
9.1	Recommended stocking of spare parts for two-year continuous operation.....	12
9.2	Section drawing .....	12
9.3	Spare-parts list .....	13

**1. General**

Assembly and installation should only be carried out by qualified personnel.

**1.1 Uses**

Pumps of the Wilo-NLB series are used to transport clean or slightly polluted (max. 20 ppm), non-aggressive liquids containing no solid components in

- Warm water heating systems
- Chilled and cooling water systems
- Water systems for industrial use
- Industrial circulating systems
- Heat transfer media circulation

**1.2 Product data**

**1.2.1 Rating plate**

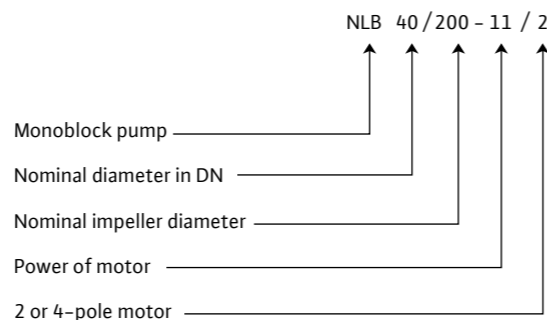

**1.2.2 Connection and electrical data**

No. of Revolutions:	2900, 1450 1/min	
Pressure support DN:	32~200	●
Permissible temperature, min./max.	- 20°C to + 120°C with mechanical seal	
Max.permissible ambient temperature	40°C	
Max. permissible working pressure:	12/16bar 25bar	● ○
Insulation class	F	
System of protection	IP55	
Motor protection	Passive thermal control (PTC)	○
Pipe joints	Flange PN 16(PN25) acc. to DIN 2533	
Pumping medium allowed	Heating water acc. to VDI 2035	●
	Service water	●
	Cooling and cold water	●
	Water-glycol mixture <sup>1)</sup>	●
	heat-conducting oil	○
Other media according to demand	○	
Electrical connection	3~220-380V, 50Hz, ≤4kW	●
	3~380V, 50Hz, >4kW	●
	other voltages/frequencies on request	○
Speed control	Control devices (Wilo control system) when using the corresponding Wilo switchgear	○
Special motor version (on request)	Special voltage/frequency and explosion-proof	○

- : Standard model
- : Special model, i.e. with additional equipment (plus supplement)
- : Alternative use of standard model (no supplement)

<sup>1)</sup> When using a water-glycol mixture containing up to ~40% glycol (or media with a viscosity different to that of pure water, the flow data for the pump must be adjusted according to the higher viscosity of the flow media, regardless of the percentage of the viscous matter. Only brand products with anti-corrosion inhibitors should be used. The manufacturer's instructions must always be strictly adhered to. When ordering spare parts, please give all the information on the pump/motor rating plate.

**2. Safety**

These instructions contain important information which must be followed when installing and operating the pump. These operating instructions must therefore be read before assembly and commissioning by the installer and the responsible operator.

Both the general safety instructions in the "Safety precautions" section and those in subsequent sections indicated by danger symbols should be carefully observed.

**2.1 Danger symbols used in these operating instructions**

Safety precautions in these operating instructions which, if not followed, could cause personal injury are indicated by the symbol:

when warning of electrical voltage with:

The following symbol is used to indicate that by ignoring the relevant safety instructions, damage could be caused to the pump/machinery and its functions: **ATTENTION!**

**2.2 Staff training**

The personnel installing the pump must have the appropriate qualifications for this work.

**2.3 Risks incurred by failure to comply with the safety precautions**

Failure to comply with the safety precautions may endanger persons and pump/system. Failure to comply with the safety precautions could also invalidate any claim for damages.

In particular, lack of care may lead to problems such as:

- Injury resulting from electrical or mechanical factors.
- Failure of important pump or machinery functions.
- Failure of prescribed maintenance and repair procedures.
- Danger to the environment through emission of hazardous substances.

**2.4 Safety precautions for the operator**

Existing regulations for the prevention of accidents must be followed.

Dangers caused by electrical energy are to be excluded. Directives issued by the VDE [German Association of Electrical Engineers] and the local electricity supply companies are to be observed.

**2.5 Safety information for inspection and assembly**

The operator is responsible for ensuring that inspection and assembly are carried out by authorised and qualified personnel who have studied the operating instructions closely.

Work on the pump/machinery should only be carried out when the machine has been brought to a standstill.

**2.6 Unauthorized modification and manufacture of spare parts**

Alterations to the pump or installation may only be carried out with the manufacturer's consent. The use of original spare parts and accessories authorised by the manufacturer will ensure safety. The use of any other parts may invalidate claims invoking the liability of the manufacturer for any consequences.

**2.7 Unauthorized operating methods**

The operating safety of the pump or installation supplied can only be guaranteed if it is used in accordance with paragraph 1 of the operating instructions. The limiting values given in the catalogue or data sheet must neither be exceeded nor allowed to fall below those specified.

### 3. Transport and storage

#### 3.1 Transport

##### 3.1.1 General recommendations

-  Existing regulations for the prevention of accidents must be followed.
  - The wearing of gloves, hard-toed boots and hard hats is compulsory for all transport work.
  - Wooden cases, crates, pallets or boxes may be unloaded with fork-lift trucks or using hoisting slings, depending on their size and construction.

##### 3.1.2 Fitting the carrying cables

-  The hoists used must have a load-bearing capacity which corresponds to the weight of the pump set. The weight is indicated on the name plate.

**ATTENTION!** To avoid any distortion, please lift the pump set as shown (Fig.1).

**Not by the ring lugs of the drive machine!**

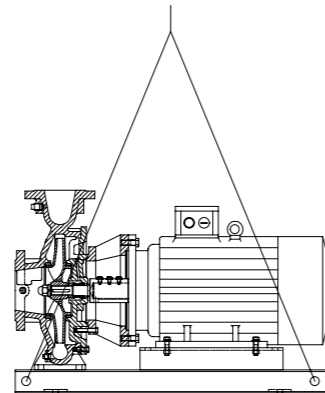

Fig.1

#### 3.2 Storage

Store the pump in a clean, dry and frost-free place where it is not exposed to vibrations. Weld the cover on the pipe connections so that no dirt or other foreign bodies can get into the pump housing. Rotate the pump shaft once a week to prevent striation of the bearings and the pump from seizing up.

Ask Wilo what preservation measures are necessary if a longer storage period is required.

### 4. Product and accessory description

#### 4.1 Pump description

Monoblock pump, install dimensions and hydraulics are in accordance with DIN EN 733

#### 4.2 Products delivered

- Pump assembly composed by bareshaft, motor and baseplate
- Pump assembly composed by bareshaft, motor and Iron cushion
- Pump assembly composed by bareshaft and motor
- Mechanical seal or packing seal
- Installation and operation instructions

#### 4.3 Accessories

Accessories must be ordered separately.

- e.g. Wilo control system, see catalogue

#### 4.4 Expected noise values as guideline

power of motor PN [kW]	Sound pressure level pA [dB] <sup>1)</sup> Pump alone		Sound pressure level pA [dB] <sup>1)</sup> Pump with motor	
	1450 <sup>-1</sup>	2900 <sup>-1</sup>	1450 <sup>-1</sup>	2900 <sup>-1</sup>
<0.55	62	62	63	64
0.75	62	62	63	67
1.1	64	64	65	67
1.5	66	66	66	70
2.2	68	68	68	71
3	70	70	70	74
4	71	71	71	75
5.5	71	73	72	83
7.5	72	74	73	83
11	73	76	74	84
15	74	77	75	85
18.5	75	79	76	85
22	75	79	77	85
30	76	81	80	93
37	76	82	80	93
45	76	83	80	93
55	77	84	82	95
75	78	86	83	95
90	78	86	85	95
110	79	87	86	95
132	79	87	86	95
160	79	88	86	96

<sup>1)</sup> Without protective sound hood, measured at a distance of 1 m directly above the driven pump, in a free space above a sound reflecting surface.

### 5. Assembly / installation

#### 5.1 Preparations

##### 5.1.1 Unlacking and inspection

The pump must be checked for compliance with the information on the delivery note; Wilo must be notified immediately of any damage or missing parts. Check crates/boxes/wrappings of spare parts or accessories which could be enclosed with the pump.

##### 5.1.2 Site

**ATTENTION!** The pump must be installed protected from the elements in a frost- and dust-free, well-ventilated and non-explosive environment.

The pump must be installed such that there is space for access, ventilation, maintenance and testing and there is sufficient space above the pump for it to be lifted.

The suction pipe should be kept as short as possible.

5.1.3 Foundation

- The pump sets can be mounted on their foundations in many different ways; which of these methods is chosen depends on the size of the pump set, its site and the noise/vibration regulations.
- To install the pump so it is insulated against vibration it is necessary to simultaneously separate the foundation block itself from the body using a flexible insert (e.g. cork or Mafund plate).

**ATTENTION!** A defective foundation or an incorrect installation of the set on the foundation could lead to a fault in the pump; this would not be covered by the warranty.

- The base must be mounted on a solid foundation, which must also be made from high-grade concrete of sufficient thickness. The base may NOT be distorted or pulled onto the surface of the foundation, but must be supported such that the original alignment remains unchanged.
- To anchor the base sufficiently, the dimensions of the fastening screws are selected / recommended in accordance with holes drilled in the base:

drilled in the base	Recommended screws		
	M	Length [mm]	threaded length [mm]
∅ [mm]			
19	16	200	40
24	20	300	50
29	24	350	60

- The concrete foundation must have set before the pump set is installed. Its surface must be flat and even.

5.2 Installation

- When installed, the complete set is to be aligned on the foundation using a spirit level. Always fit Shock pad (B) between damping foundation(D) and plinth (F) on left and right in the immediate vicinity of the fixing material (e.g. stone bolts (A)) between base (E) and damping foundation (D).

- Tighten fixing material evenly and securely.
- To further reduce vibration, after fixing, the base can be grouted with mortar which is as vibration-free as possible via opening as far as the upper edge. Voids are to be avoided when doing so.

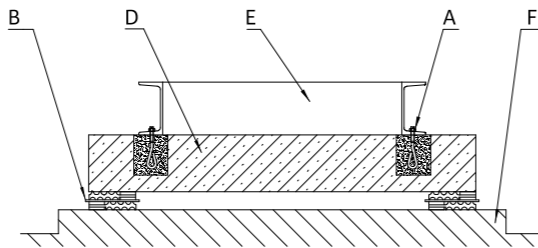

Fig.2

5.3 Connecting the pipes

**ATTENTION!** Under no circumstances may the pump be used as a fixed support for the pipe!

- The available NPSH value of the system must always be greater than the required NPSH value of the pump.
- The forces and moments exerted on the pump flange by the pipe system (e.g. through twisting, thermal expansion) may not exceed the permissible forces and moments (see 4.4).
- The pipes are to be supported immediately before the pump and connected stress-free. Their weight may not place a strain on the pump.
- The suction pipe should be kept as short as possible. The suction pipe is to be fitted always rising to the pump, and falling to the inlet. Possible air pockets are to be avoided.
- If a catch pan is required in the suction pipe, its free cross-section must be equal to 3- 4 times the cross-section of the pipe.
- For short pipes the nominal widths must at least correspond to those of the pump connections. For long pipes the most economical nominal width is to be determined in each case.
- Transition pieces to larger nominal widths should be designed with an expansion angle of approx. 8° to avoid greater pressure losses.
- Shut-off devices before and after the pump (inspection or removal) as well as necessary non-return devices should in principle be provided.
- Only connect the pipes after all welding and soldering work is finished and the system has been cleaned / rinsed.
- The flange covers at the inlet and outlet pressure gland of the pump are to be removed before connecting the piping.

Permissible branch forces and moments

Values according to ISO/DIN 5199 – Class II (1997) – Annex B, Family N° 2 for mounting on cast iron baseplate and frames without grouting for pumping temperatures up to 110 °C and up to 120°C for cast iron baseplate / frames.

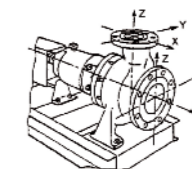

	DN	flange	Fy (N)	Fz (N)	ΣF (N)	<sup>TM</sup> F (N)	My (Nm)	Mz (Nm)	<sup>TM</sup> Mx (Nm)
Top branch Z axis	32	400	500	440	780	360	420	520	760
	40	400	500	440	780	360	420	520	760
	50	540	660	600	1040	400	460	560	820
	65	820	1000	900	1580	460	520	640	940
	80	820	1000	900	1580	460	520	640	940
	100	1080	1340	1200	2100	500	580	700	1040
	125	1620	2000	1800	3140	700	820	1000	1460
	150	1620	2000	1800	3140	700	820	1000	1460
Top branch X axis	200	2160	2680	2400	4180	920	1060	1300	1920
	50	600	540	660	1040	400	460	560	820
	65	900	820	1000	1580	460	520	640	940
	80	900	820	1000	1580	460	520	640	940
	100	1200	1080	1340	2100	500	580	700	1040
	125	1800	1620	2000	3140	700	820	1000	1460
	150	1800	1620	2000	3140	700	820	1000	1460
	200	2400	2160	2680	4180	920	1060	1300	1920
250	2980	2700	3340	5220	1260	1460	1780	2620	

**5.4 Final inspection**

- If necessary re-tighten foundation screws.
- Check all connections for trueness and operation.
- Pump shaft must be able to be easily turned by hand.

**5.5 Electrical connection**

 Electrical connection should be made by a qualified electrician. Current national regulations must be observed (e.g. VDE regulations in Germany).

- The supply cable must be laid in such a way that it never touches the pipework and/or the pump and motor casing.
- Check the mains current and voltage.
- Please observe data on the motor rating plate.
- Mains fuse: depends on nominal motor current.
- Observe earthing regulations.
- The connection diagram for the electrical connections can be found in the terminal box (see also fig. 3a, b, c).
- The special motor model is fitted with passive thermal control. These can be connected via the corresponding terminals in the terminal box.

The passive thermal control should be connected to the thermal trip mechanism.

**ATTENTION!** At the binding posts a max. voltage of 7,5V= may be used. A higher voltage destroys the passive thermal control.

It is advisable to install a protective motor switch.

Adjusting the motor safety switch:

Direct starting current: the information on the motor rating plate must be observed for the installation on the nominal current;

Y-Δ-start: If the motor safety switch is connected as a star or triangular safety circuit combination at the supply line it can be adjusted in the same way units operating on direct starting current. If the motor safety switch is connected to the motor supply line in phase (U1/V1/W1 or U2/V2/W2), then the motor safety switch should be adjusted to the value of 0.58 of the nominal motor current.

- The mains connection on the tagboard depends on the power of the motor P2, the power supply and the type of connection. The necessary connection of the bridges in the terminal box is illustrated in the following table and figure 3:

Type of switch	power of motor P <sub>N</sub> ≤4kW		power of motor P <sub>N</sub> >4kW
	power supply		power supply
	3~220V	3~380V	3~380V
direct	Δ -connection (3a)	Y-connection (3b)	Δ -connection (3a)
Y- Δ -start	Remove connecting bridges (3c)	-	Remove connecting bridges (3c)

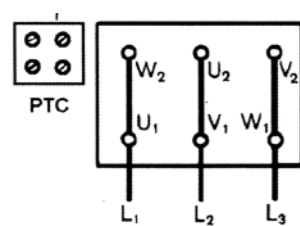

Fig. 3a

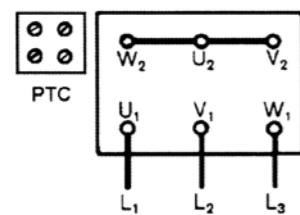

Fig. 3b

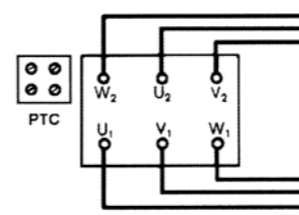

Fig. 3c

**ATTENTION!** Only check direction of rotation when system is full. Even brief dry running destroys the mechanical seal.

- Observe the installation and operating instructions when connecting automatically functioning acoustic implements.
- In the case of three-phase induction motors with Y-Δ-connection it must be ensured that the change-over points between star and triangle follow on from one another very quickly. Longer change-over times may result in pump damage.

Recommended time setting for Y-Δ-connection:

power of motor	Y-time t be set
≤30kW	< 3sec.
>30kW	< 5sec.

**6. Operation**

**6.1 Initial start-up**

- The pump, suction and supply pipes must be filled and the air must be removed.  
Close blocking device at the outlet. Fill pump via the suction pipe, whereby the blocking device at the inlet is to be fully opened.  
Fully deaerate pump via vent in pump housing, until only fluid appears. Close vent.

**ATTENTION!** Dry running damages the mechanical seal

 Depending on the fluid temperature and the system pressure, if the vent screw is completely loosened hot liquid or gas can escape or even shoot out at high pressure. Beware of scalding.

- To avoid noise and damage resulting from cavitation, it is important to ensure a minimum supply pressure at the air intake of the pump. The minimum supply pressure depends on the location and point of operation and must be determined accordingly. Considerable parameters in determining the minimum supply pressure are the NPSH value of the pump at its operation point and the steam pressure of the flow medium.
- Check whether the direction of rotation is the same as that of the arrow on the pump housing by switching on the pump for a short period of time. If the direction of rotation is incorrect the following steps should be taken:  
Direct start: exchange the 2 phases on the tagboard of the motor (e.g. L1 for L2).  
Y-V-start: rearrange the location of the lead-in and lead-out wires on the tagboard of the motor (e.g. V1 for V2 and W1 for W2).

**6.1.1 Switching on**

- Only switch on the set when the blocking device at the outlet is closed!  
Only open this slowly and set to the working point once full speed has been reached.
- The set must run smoothly and be free of vibrations.
- A mechanical seal guarantees a seal without leaks and does not require a specific setting. Any small leaks at the beginning will stop when the seal's run-in phase is complete.
- After the operating temperature has been reached and/or in the event of leaks in the pump housing, re-tighten the hexagonal screws with the set switched off.

 As soon as all work is finished, all scheduled safety and protective devices must be properly fitted and put into operation.

**6.1.2 Switching off**

- Close blocking device in the compressed-air pipe.  
If a non-return device is built into the compressed-air pipe, the blocking device can remain open provided there is a back-pressure.

 When switching off the pump the blocking device in the inlet pipe must not be closed.

- Switch off motor. Ensure quiet run-down.
- If the pump is out of operation for long periods the blocking device in the inlet pipe is to be closed.
- If the pump is out of operation for long periods and / or there is a risk of freezing the pump is to be drained or protected against freezing.

**6.2 Operation**

**ATTENTION!** The pump should always run quietly and free from vibrations and not be operated at temperatures higher than those given in the catalogue/data specification sheet.

 Depending on the operating condition of the pump and/or installation (fluid temperature) the entire pump can become very hot. Avoid touching the pump owing to the risk of burning.

- The pump can be switched on and off in different ways, depending on the various operating conditions and the degree of automation in the installation. The following is to be observed:  
 Stop procedure:
  - Avoid reverse pump operation.
  - Do not work for too long with overly small transport capacities.
 Start procedure:
  - Ensure that the pump is completely full.
  - Ensure a continuous flow to the pump with a sufficiently large NPSH value.
  - Avoid an overly weak back-pressure causing the motor to overload.
- To avoid an excessive rise in temperature in the motor and excessive strain on the pump, coupling, motor, seals and bearings, the set should not be turned on more than 10 times per hour (h).

**7. Maintenance**

**7.1 General information**

- The operator is responsible for ensuring that inspection and assembly are carried out by authorised and qualified personnel who have studied the operating instructions closely.
- By drawing up a maintenance plan, costly repairs can be avoided with a minimum of maintenance expense and a fault-free pump operation obtained. The Wilo service is available for initial start-up and maintenance work.

 Before carrying out any maintenance work, switch off the pump and ensure that it cannot be switched on again by unauthorized people. Never carry out work on a running pump.

 Depending on the operating condition of the pump and/or installation (fluid temperature) the entire pump can become very hot. Avoid touching the pump owing to the risk of burning.

**7.2 Routine maintenance**

**ATTENTION!** • In principle all seals removed during maintenance work should be replaced.

**7.2.1 Rolling bearings**

lub. grease have been added before delivery. Please add or replace the grease as specified on the motor nameplate after the equipment operation.

**Do not reuse rolling bearings following disassembly for maintenance purposes!**

**7.2.2 Shaft seals**

**Pump with mechanical seal:**

- When operating properly the mechanical seal has no visible leaks (only vapour). The mechanical seal is maintenance-free, its tightness is to be checked regularly. The slightest leak is a sign of the start of a tightness problem caused by damage to the components of the mechanical seal.

 As soon as all work is finished, all scheduled safety and protective devices must be properly fitted and put into operation.

**8. Problems, Causes and Solution**

						Transport capacity too small	
						Irregular supply	
						Motor overloaded	
						Pump leaks	
						Set vibrates	
						Temperature of pump housing too high	
						Possible causes	Solution
x	x			x	x	Pump housing or pipe system not sufficiently filled	- Check and refill
x	x			x		Air pocket in pipes	- Check and deaerate pipes
x				x	x	Pressure loss in inlet too high	- Check whether NPSH present > NPSH necessary - Friction loss in inlet and in fittings reduce (larger diameter, better choice and installation of fittings).
x					x	Motor rotating in wrong direction	- swap 2 phases at the motor supply terminal.
x	x	x				Motor in two-phase mode	- Check power supply to motor - replace faulty fuses
x						Motor speed too low	- Check terminal switching according to mains voltage
x				x		Manometric flow level too high	- Check geometric flow level. - Check friction losses (gate partly open, foreign body). - System pressure too high. - Alter installation or replace pump.
		x		x		Manometric flow level too low	- Choke pressure valve or fit a smaller impeller. - Consult Wilo Customer Service.
x				x	x	Pipe system and fittings	- Check, dismantle and clean.
				x	x	Transport capacity too low	- Check intake and pressure pipes and also fittings.
x						Seal joints worm	- Consider repairing the pump.
	x	x	x	x		Pump corroded or blocked	- Dismantle, examine and consider repairing. - Check flange load.
	x	x	x	x		Flange load too high	- Check pump/pipe flange connections - Reduction in pipe forces - (change the pipe layout, fit an expansion joint)
			x			Shaft seal not tight	- Re-tighten gland, replace packing. - Check and where necessary replace all parts of the mechanical seal (never use whilst dry).
			x			Faulty seal	- Replace seal between spiral housing and pressure cover
	x	x	x	x		Damaged ball bearings	- Check and replace the bearings(sam size and modell)
		x			x	Density or viscosity of flow medium too high	- Consult the nearest Wilo agent to find a solution to the problem.
				x		Faulty base assembly	- Check base assembly: - Re-tighten the foundation screws - Replace anchors Wedge better

**If no solution can be found, please contact your plumbing and heating specialist or your nearest Wilo customer services or representative.**

### 9. Spare parts

**ATTENTION!** It is recommended that maintenance and repairs to the set only be carried out by Wilo or authorised experts.

- All spare parts necessary for maintenance or repair can be obtained from Wilo.
- To guarantee the fault-free operation of the pump/system only Wilo original spare parts are to be used. The use of other parts (modification or use of a non-standard part) may affect liability in respect of any consequences this may have.
- When ordering spare parts
  - The pump and motor rating plate,
  - Spare part names (see spare-parts list),
  - and the number of spare parts required, must always be indicated.

#### 9.1 Recommended stocking of spare parts for two-year continuous operation

Part no.	Part name	Number of pumps (including reserve pumps)						
		2	3	4	5	6 and 7	8 and 9	10 and more
		Number of spare parts						
5	Assembly-shaft	1	1	2	2	2	3	30%
4	Impeller	1	1	1	2	2	3	30%
17	Ball bearing	2	2	4	4	6	8	100%
15	Mechanical seal	2	2	4	4	6	8	100%
-	Flat packing/O-rings(set)	4	6	8	8	9	12	150%

#### 9.2 Section drawing

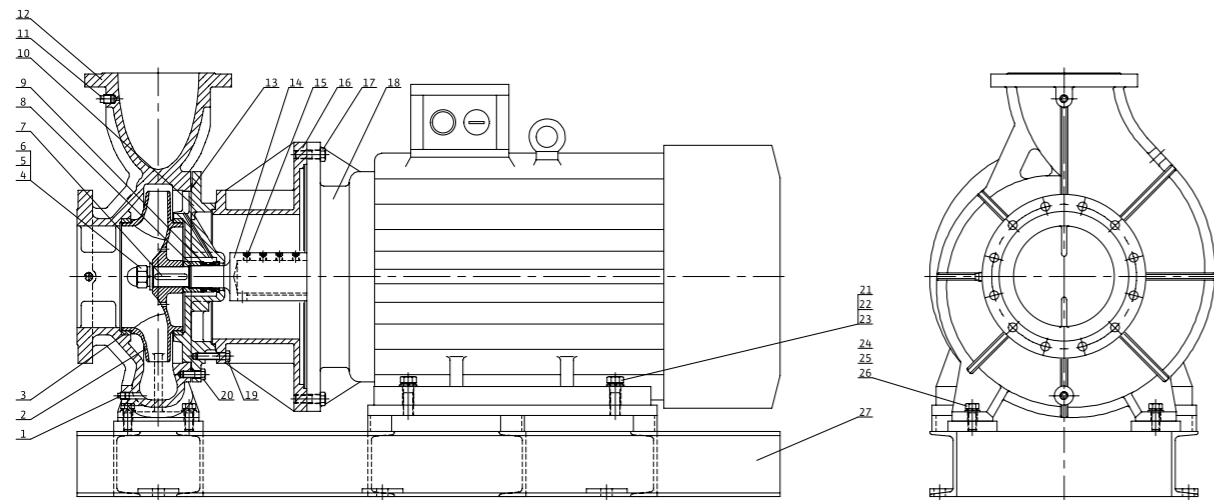

Fig.4

#### 9.3 Spare part list (Fig.4)

Part number	Part name	Qty
1	Screw plug	1
2	Impeller	1
3	Wearing	2
4	Washer	1
5	Spring Washer	1
6	Impeller Nut	1
7	Key	1
8	Spacer	1
9	Mechanical seal	1
10	Casing cover	1
11	Screw plug	2
12	Volute casing	1
13	O-Rings	1
14	Shaft	1
15	Inner Hex.bolt	3
16	Lantern	1
17	Hexagonal bolt	8
18	Motor	1
19	Hexagonal bolt	12
20	Hexagonal bolt	16
21	Washer	4
22	Spring Washer	4
23	Hexagonal bolt	4
24	Washer	4
25	Spring Washer	4
26	Hexagonal bolt	4
27	Base plate	1



# 目 录

1.	概述 .....	2
1.1	使用范围 .....	2
1.2	产品技术参数 .....	2
1.2.1	型号说明 .....	2
1.2.2	技术参数 .....	2
2.	安全说明 .....	3
2.1	说明书中使用的符号 .....	3
2.2	操作人员资质 .....	3
2.3	不遵守安全准则的危害 .....	3
2.4	操作者的安全准则 .....	3
2.5	检查和安装的安全规范 .....	3
2.6	自行改装设备和自制备件 .....	3
2.7	不允许的运行情况 .....	3
3.	运输和存储 .....	4
3.1	运输 .....	4
3.1.1	一般建议 .....	4
3.1.2	安装起重吊索 .....	4
3.2	存储 .....	4
4.	产品和附件 .....	4
4.1	水泵 .....	4
4.2	供货范围 .....	5
4.3	附件 .....	5
4.4	噪音参考值 .....	6
5.	安装 .....	6
5.1	准备 .....	6
5.1.1	开箱检查 .....	6
5.1.2	安装地点 .....	6
5.1.3	基础 .....	6
5.2	安装 .....	6
5.3	管路连接 .....	7
5.4	最后检查 .....	7
5.5	电气连接 .....	8
6.	调试 .....	8
6.1	首次启动 .....	8
6.1.1	启动 .....	9
6.1.2	关闭 .....	9
6.2	运转 .....	9
7.	维护 .....	10
7.1	概述 .....	10
7.2	常规保养 .....	10
7.2.1	滚动轴承的轴承支架 .....	10
7.2.2	机械密封 .....	10
8.	故障，故障原因及排除 .....	11
9.	零部件 .....	12
9.1	建议提供保留 2 年的零部件 .....	12
9.2	结构图 .....	12
9.3	零部件清单 .....	13

## 1. 概述

该水泵的安装和维护只能由相应的专业人员来完成。

### 1.1 应用范围

威乐 NLB 系列水泵适用于输送洁净或微污染（最大 20ppm），无腐蚀性不含固体物质的液体：

- 热水采暖系统
- 冷却水和冷冻水系统
- 工业用水系统
- 工业循环系统
- 传热循环系统

### 1.2.2 技术参数

转速：	2900, 1450 1/min	
水泵进出口名义管径 DN:	32~200	●
允许介质温度	-20°C~+120°C 机械密封	
最高允许环境温度	40°C	
最大允许工作压力	12/16bar 25bar	● ○
电机绝缘等级	F	
电机防护等级	IP55	
电机保护	PTC 传感器	○
管路连接	法兰 PN16(PN25) 根据 DIN 2533	
允许介质	采暖热水根据 VDI2035 生活用水 冷冻水 / 冷却水 水与乙二醇混合液 <sup>1)</sup> 导热油 其他介质（请来函咨询）	● ● ● ● ○ ○
电源	3~220~380V, 50Hz, ≤4kW 3~380V, 50Hz, >4kW 其他电压 / 频率（请来函咨询）	● ● ○
转速控制	控制装置（威乐控制系统）使用威乐的开关装置	○
特殊电机	特殊电压 / 频率和防爆电机	○

●：标准配置

○：特殊配置或附加配件（需另外加价）

□：可选择的标准配置（不需加价）

<sup>1)</sup> 当乙二醇含量达 40% 时（或其他介质与水具有不同的粘度），需对水泵的水力参数做相应必要的修正。只有严格符合制造商要求的防腐剂品牌添加剂才可使用，严格遵守制造商的使用说明。

在订购配件时，一定要给出水泵和电机上所有的技术参数。

## 2. 安全准则

此说明书中涵盖了该水泵安装及运行时必需严格遵守的安全准则。因此，安装人员和操作者在安装和调试水泵前必需认真阅读此说明书。

### 1.2 产品技术参数

#### 1.2.1 型号说明

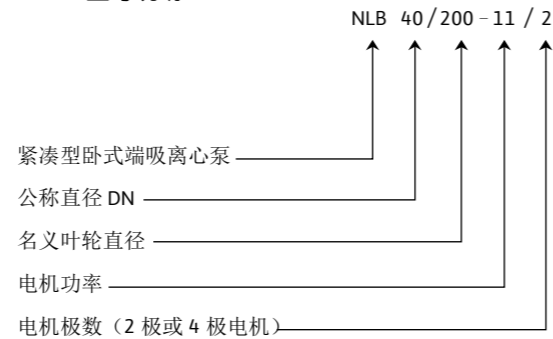

安全防范部分的安全须知和后面部分中特殊安全标志表示的安全规则都必需认真遵守。在阅读中，一定要注意安全规范，尤其是一些特殊标志的说明。

### 2.1 操作说明书中使用的标志说明

如不遵守操作说明书中的安全防范措施将引起人身伤害，表示符号：

危险，有电，表示符号：

忽视有关的安全防范措施将对水泵和机械设备及其功能造成损坏，表示符号：

### 2.2 操作人员资质

安装水泵的人员必须有相应的资质。

### 2.3 不遵守安全准则的危害

不遵守安全防范措施将引起人身伤害或水泵损坏，厂方不负任何责任，也不承担任何索赔。

具体地说，不遵守安全防范措施将导致以下危害：

- 造成电气或机械伤害。
- 水泵或设备将失去其主要或重要功能。
- 维护和维修过程造成的损害。
- 有害物质的散发对环境造成损害。

### 2.4 操作者的安全准则

必须遵守本说明书中的预防事故发生的重要规范。

排除可能引起的电能伤害。必须遵守 VDE 规范（德国电气工程师协会规范）以及当地的电气规程。

### 2.5 检查和安装的安全规范

操作者有责任确保检查和安装水泵必须由有资质的、授权批准的专业人员进行。

只有在水泵停止运行时，才能进行检修。

### 2.6 自行改装设备和自制备件

自行改装设备必须经过制造商同意，使用原厂备件将确保安全。使用其他零件，制造商将不承担由此引起的任何后果和责任。

### 2.7 不允许的运行情况

严格遵守说明书的第一章规定才能确保设备运行安全。在产品样本及数据表中的极限值不允许逾越。

## 3. 运输与存储

### 3.1 运输

#### 3.1.1 一般建议

必须遵守安全防范措施。

- 在搬运过程中，必须带手套，穿工作鞋和戴安全帽。
- 根据尺寸和结构选用叉车或提升装置来卸木箱、板条箱或货盘。
- 根据当地规范必须使用提升装置起吊重量超过 30Kg 的起吊部件。
- 只可用当地安全条例许可的吊钩来提升设备或部件。当通过突出部分或尖角时，链条或缆绳必须有保护。
- 用暴露吊钩不能直接挂载重物。重物轴线必须位于牵引力的方向上。起吊时，应考虑因存在牵引角，缆车承受力的减少。
- 所有负载均为垂直方向时，缆车最为安全和高效。必要时使用缆车能垂直到达的起重臂。
- 禁止站立在起吊的重物之下。应标出一个安全区域，当重物或部件滑落或提升装置断裂时，保证人员安全。禁止让重物长时间处于起吊状态中。在起吊过程中加速和刹车必须对人员无危险时进行。
- 如果使用滑轮或类似提升装置时，必须确保重物垂直提升。提升重物时必须防止摇晃。这个很容易达到，例如，采用副

滑轮和滑车，但其两受力绳的垂直夹角必须小于 30°。

### 3.1.2 安装起重吊索

**!** 起重装置的承载力必须大于泵组设备的重量，水泵的重量可在水泵铭牌上查到。

**注意!** 为了避免损坏，请按照下图 1 提升水泵设备。不得从电机吊环处起吊。



图 1

### 3.2 存储

水泵应存放在干净，干燥和无霜冻的环境中，严禁受到外力损害。为防止灰尘或异物进入泵体，在水泵的进出口放上盖板。每周旋转泵轴一次以防止轴承产生纹痕和轧住。

若需长期储存请咨询威乐公司，必须采取保护措施。

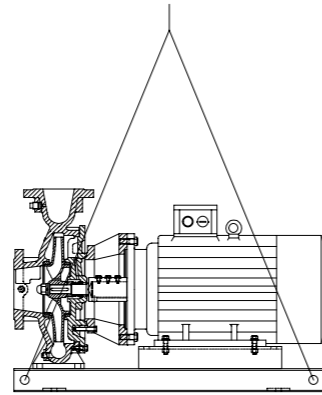
## 4 产品和附件

### 4.1 水泵

紧凑型卧式端吸离心泵，安装尺寸和性能符合 DIN EN 733 标准。

### 4.2 供货范围

- 由泵头、电机和底座组成的整泵
- 由泵头、电机和垫铁组成的整泵
- 由泵头和电机组成的整泵
- 安装及操作维护说明书

### 4.3 附件

附件必须另行订购。

- 例如，威乐的控制系統。

### 4.4 噪声参考值

电机功率 [kW]	声压级 PA [dB] <sup>1)</sup> 泵头		声压级 PA [dB] <sup>1)</sup> 水泵和电机	
	转速 1450 <sup>-1</sup>	转速 2900 <sup>-1</sup>	转速 1450 <sup>-1</sup>	转速 2900 <sup>-1</sup>
<0.55	62	62	63	64
0.75	62	62	63	67
1.1	64	64	65	67
1.5	66	66	66	70
2.2	68	68	68	71
3	70	70	70	74
4	71	71	71	75
5.5	71	73	72	83
7.5	72	74	73	83
11	73	76	74	84
15	74	77	75	85
18.5	75	79	76	85
22	75	79	77	85
30	76	81	80	93
37	76	82	80	93
45	76	83	80	93
55	77	84	82	95
75	78	86	83	95
90	78	86	85	95
110	79	87	86	95
132	79	87	86	95
160	79	88	86	96

<sup>1)</sup> 平均声压级值指在距电动机表面 1 米的空间区域测量的。

## 5. 安装

### 5.1 准备

#### 5.1.1 开箱检查

水泵必须按发货单检查；任何损坏或丢失情况必须立即告知威乐公司。并检查随泵封在一起的备件或附件的包装。

#### 5.1.2 安装地点

**注意!** 水泵必须安装在无霜冻无尘，通风良好，无爆炸的环境中。

水泵应安装在宽敞、通风、方便维修和测试的地方，以及还须有足够的空间用于水泵的提升。

进水管道应尽可能的短。

#### 5.1.3 基础

- 水泵可以采取不同的安装方式；根据水泵的尺寸，地点和噪音 / 振动选择安装方法。
- 为了隔振，安装水泵时必须在基础与泵体间加入弹性垫层（如：软木垫圈，隔振板）。

**注意!** 有缺陷的基础或不在基础上正确的安装会导致水泵故障；而这不属于质保范围。

- 水泵必须安装在牢固的基础上，基础必须由足够厚的高等级混凝土作成。水泵的基础不允许变形。
- 为了固定基础，对于不同基础的孔径我们推荐不同的螺栓：

基础孔径	推荐螺栓		
	M	长度 [mm]	螺纹长度 [mm]
Ø [mm]			
19	16	200	40
24	20	300	50
29	24	350	60

- 混凝土基础应在水泵安装之前做好。其表面应平整光滑。

### 5.2 安装

- 在安装的时候，全部设备在基础上按同一水平排列。首先把隔振垫（B）放在隔振座（D）与基础（F）之间，紧靠隔振座左侧和右侧。底座（E）和隔振座（D）用地脚螺栓（A）连接。

- 均匀拧紧固定材料。

- 为了进一步避免振动，固定后，基座可以通过上面的开口用水泥浆填塞，这样可以在运行过程中最大可能的减少振动。填充时，要避免空隙。



图 2

### 5.3 管路连接

**注意!** 任何情况下水泵都不能作为管路的支撑承重基础。

- 管路系统的 NPSH 值必须大于水泵要求的 NPSH 值。
- 管路系统（例如扭曲，热膨胀）对泵法兰的压力和力矩不能超过允许的压力和力矩。
- 管路必须在泵安装前支撑好，并避免应力。不得将其重量加在泵上。
- 进水管尽可能短。进水管的安装应先提升到泵上端，再下落到泵进口。避免空气进入。
- 如果要在进水管路上安装集水盘，其截面积必须是管路的 3-4 倍。
- 短管的公称尺寸至少与水泵接口相一致。长管的公称尺寸视具体情况而定。
- 过渡到更大截面管路时，扩展角设计应在 8° 左右以防止较大的水力损失。
- 原则上泵前后端应配截止阀或止回阀以满足检修或拆卸搬运的需要。
- 只能在管路焊接工作完成和管道系统被清洁冲洗后方可连接管路系统。
- 在连接管路之前，进、出口法兰盖须拆除。

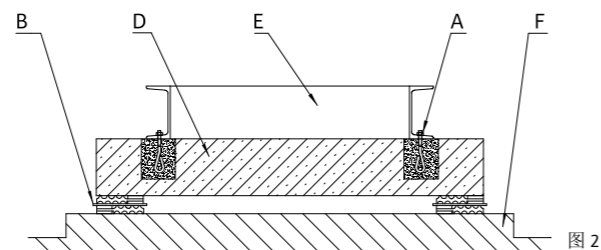
### 5.4 最后检查

- 如有必要重新拧紧基座的螺钉。
- 检查所有的连接。
- 泵轴必须用手就可以轻松的盘动。

### 5.5 电气连接



电气连接必须由有资格的电工完成。必须遵守当前的国家法规（例如德国的 VDE）。

- 必须避免电源线与管路 / 水泵和电机壳体接触。
- 检查主电源和电压。

### 法兰允许承受的力和力矩

数值符合 ISO/DIN 5199-Class II (1997) 标准，水泵安装在铸铁或者焊接底座上介质温度可达 110°C，如果对基础进行灌浆介质温度达到 120°C。

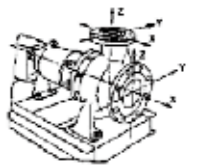

	DN	F <sub>x</sub> (N)	F <sub>y</sub> (N)	F <sub>z</sub> (N)	ΣF(N)	<sup>TM</sup> F(N)	M <sub>y</sub> (Nm)	M <sub>z</sub> (Nm)	<sup>TM</sup> M <sub>x</sub> (Nm)
Z轴 方向	32	400	500	440	780	360	420	520	760
	40	400	500	440	780	360	420	520	760
	50	540	660	600	1040	400	460	560	820
	65	80	1000	900	1580	460	520	640	940
	80	820	1000	900	1580	460	520	640	940
	100	1080	1340	1200	2100	500	580	700	1040
	125	1620	2000	1800	3140	700	820	1000	1460
	150	1620	2000	1800	3140	700	820	1000	1460
X轴 方向	200	2160	2680	2400	4180	920	1060	1300	1920
	50	600	540	660	1040	400	460	560	820
	65	900	820	1000	1580	460	520	640	940
	80	900	820	1000	1580	460	520	640	940
	100	1200	1080	1340	2100	500	580	700	1040
	125	1800	1620	2000	3140	700	820	1000	1460
	150	1800	1620	2000	310	700	820	1000	1460
	200	2400	2160	2680	4180	920	1060	1300	1920
250	2980	2700	3340	5220	1260	1460	1780	2620	

- 检查电机铭牌上的数据。
- 电源保险丝：根据电机满载电流决定。
- 遵守接地规程。
- 电源接线图在接线盒内表面上（见图 3a,b,c）。
- 特殊类型的电机采用温度控制。它们可以通过对应的终端在接线盒里进行连接。
- 温度控制应与热断路装置连接。

**注意!** 附带的说明上允许使用的最大电压为 7.5V。高压会毁坏被动热控。

- 安装电机保护开关。
- 调节电机保护开关：

直接启动：根据电机铭牌上的参数设定额定电流。

Y- $\Delta$  启动：如果电源线 and 电机保护开关的连接是星形或三角形安全电路的组合，可以采用和设备直接启动电流相同的调节方式。如果电机安全开关是按相 (U1/V1/W1 或 U2/V2/W2) 连接的，那么电机安全开关应调节到电机额定电流的 0.58 倍。

- 电源的连接方式由电机额定功率 P<sub>2</sub>，电压和启动方式而定。搭桥连接参照下表和图 3。

启动方法	电机功率 P <sub>N</sub> ≤4kW		电机功率 P <sub>N</sub> >4kW
	主电源		主电源
	3~220V	3~380V	3~380V
直接启动	$\Delta$ - 连接 (3a)	Y- 连接 (3b)	$\Delta$ - 连接 (3a)
Y- $\Delta$ -start	去除连接桥 (3c)	-	去除连接桥 (3c)

**注意!** 当系统满负荷时，仅检查转子的方向。短暂的干转也会损坏机械密封。



图 3a



图 3b

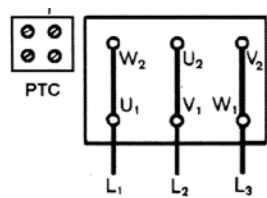

图 3c

- 连接自动运行装置时，要遵守安装运行指导书。
- 三相感应电动机采用 Y- $\Delta$  连接时，必须保证 Y 和  $\Delta$  转换点快速的切换。过长的转换时间会对水泵造成损坏。

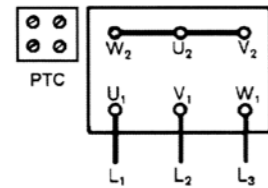
推荐 Y- $\Delta$  连接的时间设置：

电机功率	切换时间设定
≤30kW	< 3sec.
>30kW	< 5sec.

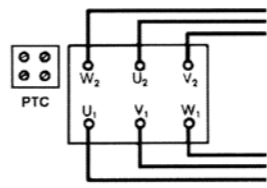
## 6. 调试

### 6.1 首次启动

- 泵体，进水管路必须注满介质，且必须排出空气。

**注意!** 关闭出口阀门。完全打开进口阀门使泵注满水。通过泵体的排气阀，使水泵完全除去空气，直到液体流出。关闭排气阀。禁止水泵干转。干转会损坏机械密封。



根据介质温度和系统压力，如果完全拧松放气螺栓，热的液体或气体就会在高压下喷出。小心烫伤！

- 为了避免气蚀造成的噪音和破坏，必须确保进水口的最小进口压力。最小进口压力根据水泵的运行条件及水泵的工况点决定，必须进行相应的计算。决定最小进口压力的参数是水泵的 NPSH 值和介质的汽化压力。
- 点动水泵，检查水泵的转动方向，确保转动方向与电机上所示箭头一致。如果转动方向不一致，请按如下操作：  
直接启动：调换电机接线的任意两相（例如 L1 和 L2）。  
Y- $\Delta$  启动：调换任意 2 个绕组的电机接线（例如 V1 和 V2 调换，W1 和 W2 调换）。

#### 6.1.1 启动

- 只有出口阀门关闭时才能启动。  
缓慢地开动水泵，并在到达全速时调节到工作点。
- 系统必须平稳运转，无异常振动。
- 保证机械密封没有泄露，且不需要特殊的装置。当密封的试车状态完毕，如有任何的泄露，要停止运转。
- 在达到操作温度和发生泵体泄露后，关闭水泵，重新拧紧螺丝。
- 在达到操作温度和发生泵体泄露后，关闭水泵，重新拧紧螺丝。



一旦所有准备工作结束，必须保证所有的安全和保护装置正确安装，并投入使用。

#### 6.1.2 关闭

- 关闭出口管路的闸阀。
- 如果在出口管路安装了止回阀，有负压情况下，闸阀可以保持开启状态。  
当关闭水泵时，进口管路的闸阀一定不能关闭。
- 关闭电机。停泵应平稳。
- 如果水泵长时间不运转，关闭进口管路的闸阀。
- 如果水泵长时间不运转 / 有冰冻的危险，放空水泵或采取防冻措施。

## 6.2 运转

**注意!** 水泵应该保持平稳运转，无异常振动，且不能在高于样本 / 技术说明书规定的温度下运转。



由于水泵的安装和运行情况不同，水泵可能会很热。避免接触水泵而造成烫伤。

- 水泵可以以不同的方式开启和关闭，要根据不同的运行条件和设备安装时的自动化程度而定。  
遵守的规则如下：

停止过程： - 避免水泵反转

- 不要让水泵长时间低流量运转

启动过程： - 确保水泵完全注满了介质。

- 确保水泵具有足够大的 NPSH 值的连续流量。
- 避免背压过低，防止电机过载。

- 避免电机温度过高，避免水泵、联轴节、电机、密封和轴承的应力过大，电机每小时启动次数不能超过 10 次。

## 7. 维护

### 7.1 概述

- 操作人员必须确认检查和装配系统的人员必须是认真研究了操作手册的有资格和授权的合格人员。
- 通过制定维护计划，降低维护成本，使泵长期正常运转。威乐售后服务负责维护工作。

 在进行维护和维修工作之前，关闭水泵，确保无关人员不会触动开关。一定不要对运转的水泵进行保养。

 由于水泵的安装和运行情况（流体温度）不同，水泵可能会很热。避免接触水泵而造成烫伤。

## 7.2 常规保养

**注意!** • 通常所有在保养时拆下的机械密封应该更换。

### 7.2.1 滚动轴承

• 出厂时轴承已经由制造商加入润滑油脂，后期运行请根据电机铭牌定期维护加注油脂。

不能重新使用拆卸下的滚动轴承！

### 7.2.2 机械密封

机械密封：

• 正常运转时，机械密封无明显的泄露。机械密封不需特殊的保养，定期检查紧固性。

轻微的泄露可能是机封损坏的信号。

 一旦所有准备工作结束，必须保证所有的安全和保护装置正确安装，并投入使用。

## 8. 故障，故障原因及排除

水泵流量过低							
水泵不规则运转							
电机过载							
水泵泄露							
振动							
泵体温度过高							
					可能原因	措施	
x	x			x	x	泵体或水泵系统未充满	- 检查和重新注水
x	x			x		管道内有气泡	- 检查和除去管道中气泡
x				x	x	进口压力过高	- 检查 NPSH 值 >NPSH 要求值 - 减小进口的阻力 (增大管径)
x					x	电机转向错误	- 任意调换电机接线的 2 相
x	x	x				2 相电机	- 检查电机额定功率 - 更换保险丝
x						转速过低	- 根据电源电压，检查接线端子
x				x		压力过高	- 检查流量 - 检查摩擦阻力 - 系统压力过高 - 修改安装或更换水泵
		x		x		压力不足	- 进口阀门堵塞或适合小叶轮 - 向威乐公司咨询
x				x	x	管路系统	- 检查和清洁
				x	x	流量过低	- 检查进口和出口管路
x						密封磨损	- 考虑维修水泵
	x	x	x	x		水泵腐蚀或堵塞	- 拆除、检测并考虑维修 - 检查法兰承载
	x	x	x	x		法兰荷载高	- 检查水泵 / 管道法兰连接 - 减小管路受力 - 改变管路布置
			x			轴套不紧固	- 重新紧固密封压盖，更换密封圈 - 检查和更换机械密封的所有部件
			x			机械密封损坏	- 更新机械密封
	x	x	x	x		电机轴承损坏	- 检查和更换轴承
		x			x	流体的密度和速度过高	- 向威乐公司咨询
				x		基础装配错误	- 检查基础装配： - 重新紧固基础螺丝 - 更换螺钉

如果故障仍没有排除，请与威乐公司联系。

## 9. 零部件

**注意!** 我们建议，水泵的维护和维修只能由威乐公司有资质的人员负责。

- 所有零部件只能由威乐公司提供。
- 只能使用威乐公司提供的零部件，确保水泵 / 水泵系统无故障运行。自行改装或非标准零部件的使用，须经制造商同意，使用原始备件将确保安全。使用其它零件，制造商将不承担由此引起的任何后果和责任。
- 订购零部件时请参考
  - 水泵和电机铭牌；
  - 零部件名称（见零部件清单）；
  - 需标识零部件编号。

### 9.1 建议提供保留 2 年的零部件

编号	零部件名称	水泵数量						
		2	3	4	5	6 和 7	8 和 9	≥10
		零部件数量						
5	装配轴	1	1	2	2	2	3	30%
4	叶轮	1	1	1	2	2	3	30%
17	滚珠轴承	2	2	4	4	6	8	100%
15	机械密封	2	2	4	4	6	8	100%
-	平垫片 / O 型圈	4	6	8	8	9	12	150%

### 9.2 结构图



图 4

### 9.3 零部件清单 (图 4)

零部件编号	零部件名称	数量
1	丝堵	1
2	叶轮	1
3	耐磨环	2
4	平垫圈	1
5	弹簧垫圈	1
6	盖形螺母	1
7	键	1
8	机封定位环	1
9	机械密封	1
10	泵盖	1
11	丝堵	2
12	泵体	1
13	O 型圈	1
14	泵轴	1
15	内六角凹端紧定螺钉	3
16	连接架	1
17	六角头螺栓	8
18	电机	1
19	六角头螺栓	12
20	六角头螺栓	16
21	平垫圈	4
22	弹簧垫圈	4
23	六角头螺栓	4
24	平垫圈	4
25	弹簧垫圈	4
26	六角头螺栓	4
27	公共底座	1

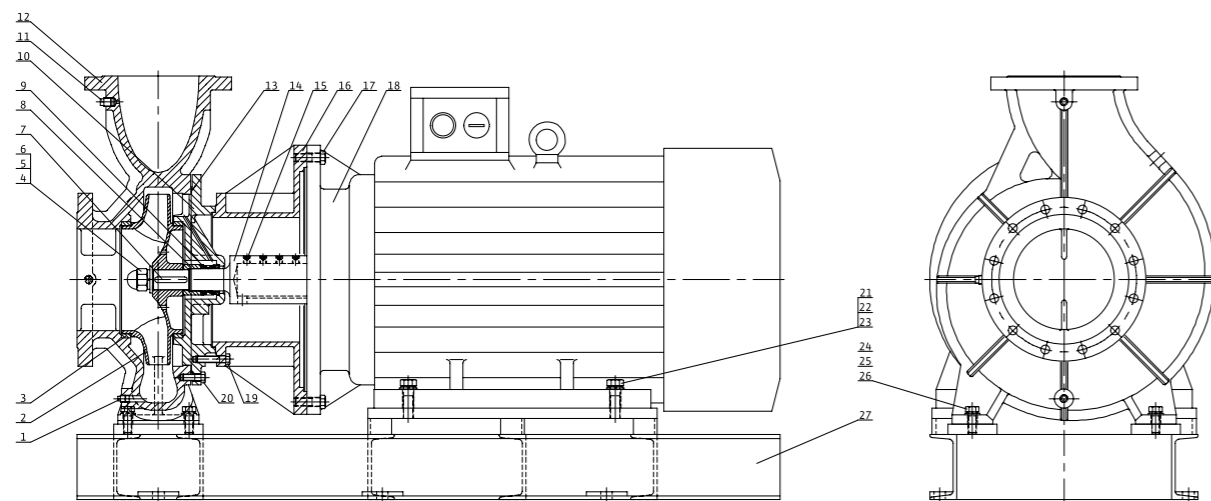

**威乐中国总部**

**威乐（中国）水泵系统有限公司**

**Wilo China Ltd.**

厂区地址(Plant Address): 北京市顺义区空港工业区 C 区兆丰一街 101300  
zhaofeng 1<sup>st</sup> Street, Airport Industrial Zone C, Shunyi District,  
Beijing, China 101300

电话(Tel): 010-52347888

传真(Fax): 010-52347666

E-mail: [wilo.info@wilo.com.cn](mailto:wilo.info@wilo.com.cn)

[Http://www.wilo.com.cn](http://www.wilo.com.cn)

销售热线: 800-810-8049

售后服务热线: 400-898-4886

**威乐欧洲股份有限公司**

WILO SE

Nortkirchenstraße 100

44263 Dortmund

Germany

T +49 231 4102-0

F +49 231 4102-7363

[wilo@wilo.com](mailto:wilo@wilo.com)

[www.wilo.com](http://www.wilo.com)

威乐公司不断改进和创新产品，若技术参数发生改变，以变更后数据为准。