

## Wilo-Control SC-Fire Diesel A2P



**en** Installation and operating instructions

Fig. 1

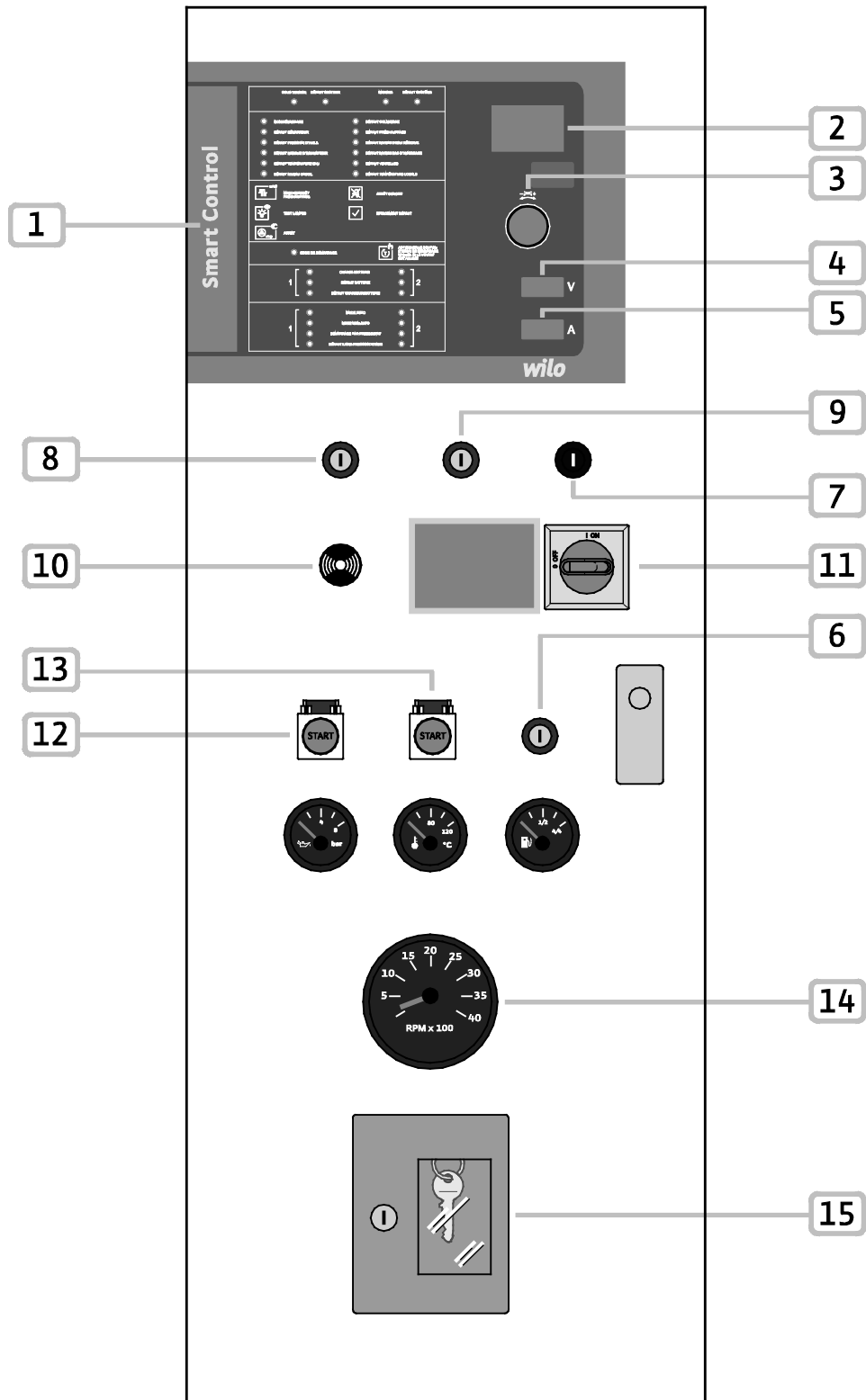

Fig. 1

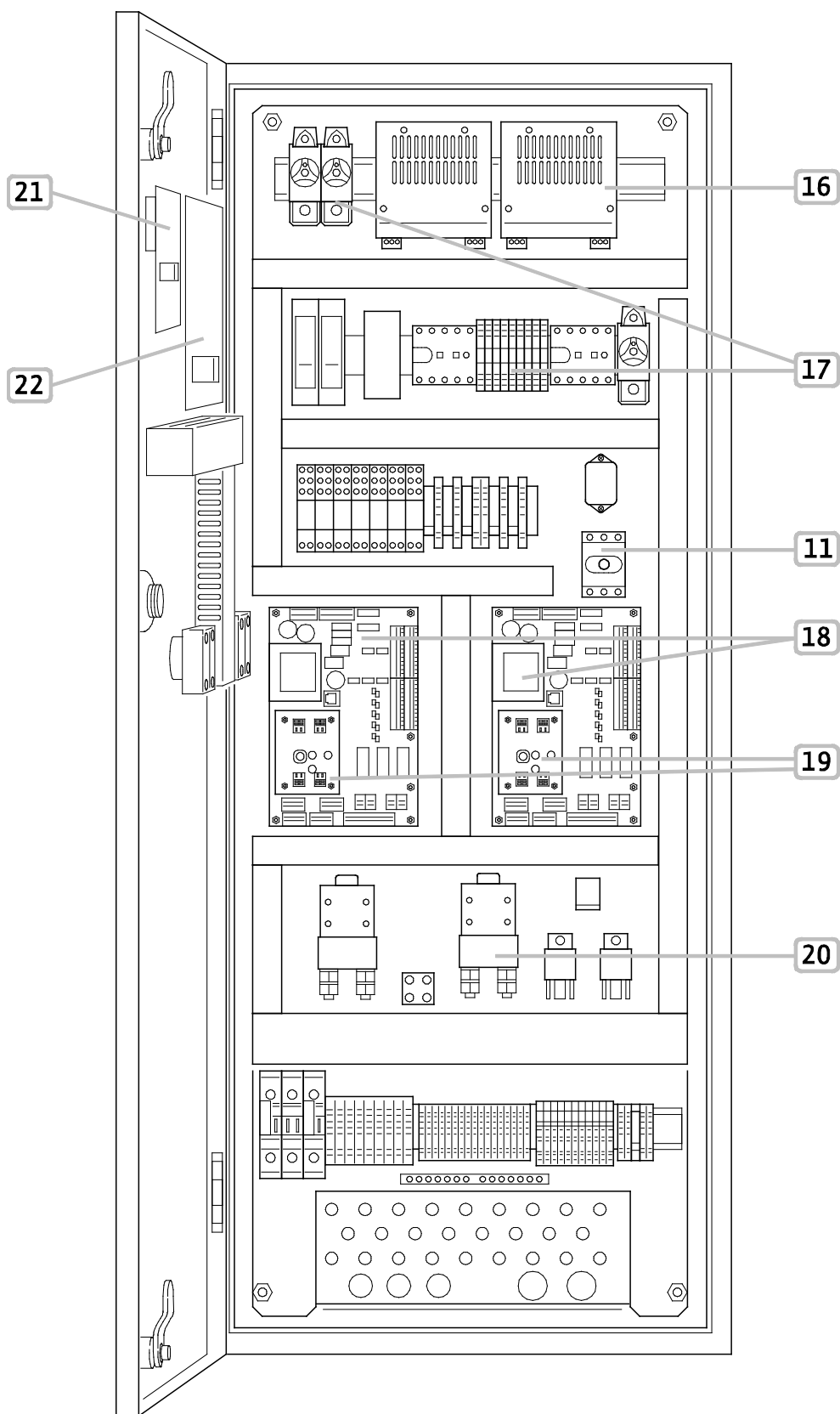
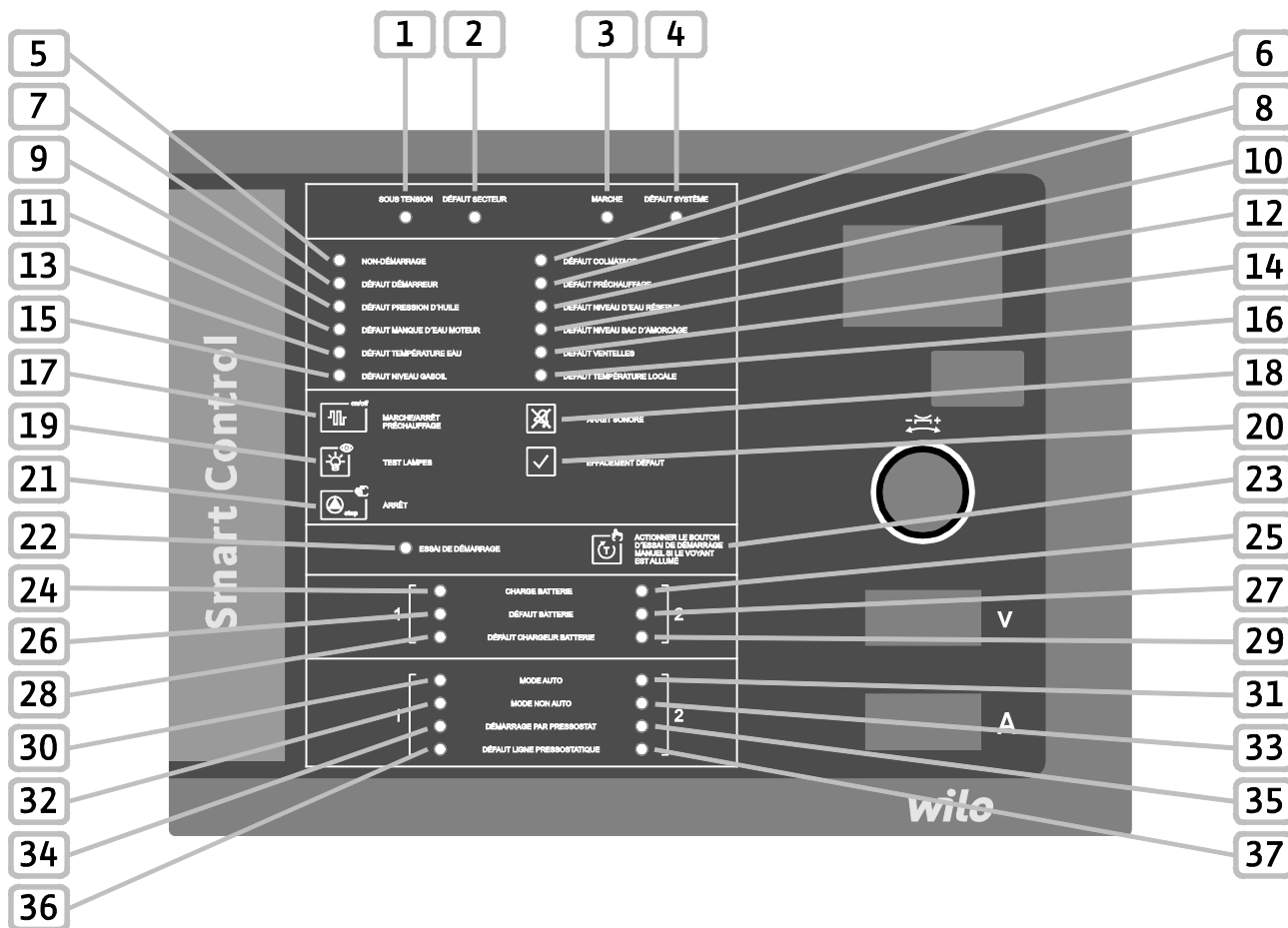

Fig. 2



# 1 General

## About this document

The language of the installation and original operating instructions is German. All other languages of these instructions are translations of the original installation and operating instructions.

The installation and operating instructions are an integral part of the product. They must be kept close to the product and be ready for use if necessary. Strict adherence to these instructions is a precondition for the proper use and correct operation of the product.

These installation and operating instructions correspond to the relevant version of the product and the underlying safety standards valid at the time of going to print.

### EC-Declaration of conformity:

A copy of the EC-Declaration of conformity is an integral part of these installation and operating instructions.

If a technical modification is made on the designs listed therein without prior approval or the declarations made in the installation and operating instructions on product/personnel safety are not observed, this declaration loses its validity.

# 2 Safety

These installation and operating instructions contain important information which must be adhered to during installation, operation and maintenance. For this reason, these instructions must, without fail, be read by the service technician and the responsible specialist/operator before installation and commissioning.

It is not only the general safety instructions listed under the main point "safety" that must be adhered to but also the special safety instructions with danger symbols included under the following main points.

## 2.1 Symbols and signal words used in the installation and operating instructions

### Symbols:



**Danger: Imminent hazardous situation.**  
**Non-observance may result in death or severe injury.**



**Danger: Danger due to electrical voltage.**  
**Non-observance may result in death or severe bodily injuries by electric shock.**



Useful or important information

**WARNING!**  
**Non-observance may result in severe injury.**

**WARNING!**  
**Non-observance may result in a risk of damage of material or of the unit.**

**NOTE:**

Useful information on handling the product. It draws attention to possible problems.

Information that appears directly on the product, such as:

- Direction of rotation arrow
- Identification for connections
- Rating plate
- Warning stickers

must be strictly complied with and kept in legible condition.

## **2.2 Personnel qualifications**

The installation, operating and maintenance personnel must have the appropriate qualifications for this work. Area of responsibility, terms of reference and monitoring of the personnel are to be ensured by the operator. If the personnel are not in possession of the necessary knowledge, they are to be trained and instructed. This can be accomplished if necessary by the manufacturer of the product at the request of the operator.

## **2.3 Danger in the event of non-observance of the safety instructions**

Non-observance of the safety instructions can result in risk of injury to persons and damage to the environment and the product/unit. Non-observance of the safety instructions results in the loss of any claims to damages.

In detail, non-observance can, for example, result in the following risks:

- Danger to persons due to electrical, mechanical and bacteriological influences.
- Damage to the environment due to leakage of hazardous materials.
- Property damage.
- Failure of important product/unit functions.
- Failure of required maintenance and repair procedures.

## **2.4 Safety consciousness on the job**

The safety instructions included in these installation and operating instructions, the existing national regulations for accident prevention together with any internal working, operating and safety regulations of the operator are to be complied with.

## **2.5 Safety instructions for the operator**

This appliance is not intended for use by persons (including children) with reduced physical, sensory or mental capabilities, or lack of experience and knowledge, unless they have been given supervision or instruction concerning use of the appliance by a person responsible for their safety.

Children should be supervised to ensure that they do not play with the appliance.

- If the product/unit poses a threat due to components being too hot or too cold, these components must be protected by the customer against touching.
- Guards that protect against coming into contact with moving components (such as the coupling) must not be removed whilst the product is in operation.
- Hazardous fluids (e.g. from the shaft seals) which have leaked (which are explosive, toxic or hot) must be eliminated so that no danger to persons or to the environment arises. National statutory provisions are to be complied with.
- Highly flammable materials are always to be kept at a safe distance from the product.
- Danger from electrical current must be eliminated. Local directives or general directives [e.g. IEC, VDE etc.] and instructions from energy supply companies must be adhered to.

## 2.6 Safety instructions for installation and maintenance work

The operator must ensure that all maintenance and installation work is carried out by authorised and qualified personnel, who are sufficiently informed based on their own detailed study of the installation and operating instructions.

Work on the product/unit must only be carried out when at a standstill. It is mandatory that the procedure described in the installation and operating instructions for shutting down the product/unit be complied with. Immediately on conclusion of the work, all safety and protective devices must be put back in position and/or recommissioned.

## 2.7 Unauthorised modification and manufacture of spare parts

It is strictly forbidden to use batteries for any other purpose than to start the diesel motor.

## 3 Transport and interim storage

Upon receipt of the product:

- Check for any damage that may have occurred during transit.
- In the event of damage in transit take the necessary steps within the period defined by the transport company within the time constraints.



**WARNING! Risk of material damage!**

**Non-compliant transport and interim storage may cause material damage to the product.**

- **The switchgear must be protected against humidity and any mechanical damage.**
- **The product must not be exposed to temperatures lower than -10 °C and higher than +50 °C.**

## 4 Intended use

The SC-Fire A2P Diesel switchgear controls pumps in automatic pumping installations used for fire-fighting purposes (sprinkler systems).

The design of this switchgear adheres to the technical regulations defined in the T1-1 of the A2P trademark. The installation, functioning and maintenance are also defined in these technical regulations.

The relevant fields of application are habitable buildings, offices, hospitals, hotels, administrative and industrial buildings.

## 5 Product information

### 5.1 Type key

Example:		W-CTRL-SC-F-1x(2)KW-M-FM-ND-D-FR
W	W = WILO	
CTRL	Operation	
SC	Smart Control = Control unit	
F	F = Fire fighting application	
1x	Number of pumps	
(2)	<u>Rated power range of the diesel motor [kW]:</u> 4.25 – 47.7 kW 66 – 145 kW 197 – 246 kW	
M	Power supply: 1 x 230 V/50 Hz	
FM	Frame mounted	
ND	New design of the electrical/control cabinet	
D	Diesel cabinet	
FR	France – box conforms to A2P	

Table 1 - Type key

### 5.2 Technical data (standard execution)

Technical data	
Mains connection voltage [V]:	1~230 V (L, N, PE)
Frequency [Hz]:	50/60 Hz
Control voltage [V]:	12/24 V DC
Absorbed current max [A]:	See the rating plate
Protection class:	IP44
Fuse protection max on mains side [A]:	See circuit diagram
Room temperature [°C]:	0 °C to +50 °C
Electrical safety:	Pollution degree II
Alarm/signal contact:	250 V AC, 1 A

Table 2 - Technical data

### 5.3 Scope of delivery

- Switchgear
- Circuit diagram
- Installation and operating Instructions
- Check log in accordance with EN 60204-1

### 5.4 Accessories



## 6 Description and function

### 6.1 Product description

#### 6.1.1 Function

The switchgear is used to operate a diesel motor pump in the sprinkler system in accordance with A2P (T1-1).

The manual start-up of the diesel motor is done from the HMI of the switchgear.

Contrary to automatic start-up which is generated by a lack of pressure in one of the 2 pressure switches.



Each pump has 2 pressure switches and each pressure switch has an Auto/0/Manu key switch.

The automatic start-up of the diesel motor follows a start-up sequence which allows for the generation of 6 start-up attempts, the 2 batteries are used in the course of this sequence.

The status of the unit can be seen on the front of the support box:

- From the LED panel
- From the LCD
- From the audible warning

The operation is performed by means of the rotary knobs, key switches and screen pushbuttons also located on the front of the box.

It is possible to perform an emergency start by means of the 2 buttons on the front of the cabinet. In this way, the battery voltage is directly applied to the terminals of the diesel starter, without going through the control.

The water level in the start-up tank is monitored at all times. If the level in the tank goes under 2/3 of the “full tank” level, then the diesel motor starts up to supplement the level.

Potential-free contacts are ready to transmit the collective run/malfunction signals to the BMS device.

#### 6.1.2 Structure of the switchgear

The structure of the switchgear may vary according to the performance of the pump to be connected.

The switchgear includes the following components:

- Main switch (Fig. 1, pos. 11): Power supply of the switchgear
- Human Machine Interface (HMI):
  - LCD screen enabling operational data to be displayed (see menus) (Fig. 1, pos. 2),
  - LED indication of the status of the system (functioning/malfunctioning) (Fig. 1, pos. 1),
  - Control button enabling menu navigation, menu selection and entering of parameters (Fig. 1, pos. 1, 2, 3).
- Key switch (Fig. 1, pos. 8 and 9): Operation mode (Auto/0/Manu) of pressure switches 1 and 2
- Screen display indicating the voltage and battery charging current (Fig. 1, pos. 4, 5)
- Key switch (Fig. 1, pos. 6): access to level 2
- Battery selection switch (Fig. 1, pos. 7): selection of the battery for the voltage and current displays (Fig. 1, pos. 4, 5)
- Audible warning: Activated in case of an alarm (Fig. 1, pos. 10)

- Base printed circuit board: printed circuit board with micro-controller. (Fig. 1, pos. 18)
- Printed circuit board of the converter: conversion of the voltage from 12 V DC to 24 V DC, conversion of the speed rotation signal (Fig. 1, pos. 19)
- Fuse protection of components: fuse protection of the control and connected components (Fig. 1, pos. 17)
- Contactors/relay: contactors/relay to activate the starter and the electromagnets (Fig. 1, pos. 20)
- Chargers: To automatically charge and keep the diesel batteries charged (Fig. 1, pos. 16)
- Emergency start button: start-up of the diesel motor with battery 1 or 2, carried out independent of the control (Fig. 1, pos. 12, 13)
- Diesel indicators (Fig. 1, pos. 14): display showing the fuel level, temperature of the cooling water, oil pressure and speed of the diesel motor
- Key box: enables the storage of the keys from the key switches (Fig. 1, pos. 15)
- Printed circuit board "SC Display": printed circuit board with display and rotary knob (Fig. 1, pos. 21)
- Printed circuit board "SC I/O": printed circuit board with control/operating console (Fig. 1, pos. 22)

## 6.2 Function and operation



**DANGER! Risk of fatal injury!**

**When working on an open switchgear, there is a risk of electrocution in the event of contact with the conductor components.**

**Only authorised and qualified personnel may carry out the work!**



Following connection of the switchgear to the connection voltage as well as after each network cut-off, the switchgear reverts to the operating mode set before the voltage cut-off.

### 6.2.1 Operating modes of the switchgear

#### Activation/deactivation of the switchgear

Once the batteries are connected to the switchgear and the voltage supply has been established, the control is operational after a few seconds. The green LED indicating the operational readiness (Fig. 2, pos. 1) is turned on.

By default, the remaining time before changeover to the other battery and charger is indicated on the LCD.

The chargers and the heating which maintain the temperature of the motor oil constant can be switched on or off via the main switch.

To stop the operation, the terminals of connected batteries and the main switch must be disconnected.

## Operating mode

The operating mode of the switchgear is configurable via the 2 key switches, simply select one of the three positions on the key switches “Auto”, “0” or “Manual”.

Diesel motor start-up in case of ...		Key switch no. 1 (for the pressure switch no. 1)		
		AUTO	OFF	MANUAL
Key switch no. 2 (for the pressure switch no. 2)	AUTO	Activation of pressure switch no. 1 or Malfunction of pressure switch no. 1 or Activation of pressure switch no. 2 or Malfunction of pressure switch no. 2 or Detection of a low level of the start-up tank	Activation of pressure switch no. 2 or Malfunction of pressure switch no. 2 or Detection of a low level of the start-up tank	Activation of pressure switch no. 2 or Malfunction of pressure switch no. 2 or Detection of a low level of the start-up tank or Key switch no. 1 in “Manual” position
	OFF	Activation of pressure switch no. 1 or Malfunction of pressure switch no. 1 or Detection of a low level of the start-up tank	-	Key switch no. 1 in “Manual” position
	MANUAL	Activation of pressure switch no. 1 or Malfunction of pressure switch no. 1 or Key switch no. 2 in “Manual” position or Detection of a low level of the start-up tank	Key switch no. 2 in “Manual” position	Key switch no. 1 in “Manual” position or Key switch no. 2 in “Manual” position

**Table 3: Operating modes**

### Automatic mode

To operate the unit in automatic mode, put the key switches (Fig. 1, pos. 8, 9) in the “Auto” position, the “Auto” position is thus confirmed by the 2 green LEDs on the HMI (Fig. 2, pos. 30, 31).

The unit starts up automatically once the pressure switch no. 1 activates (drop in pressure, contact opening width) and the key switch no. 1 is in the “Auto” position or once the pressure switch no. 2 activates and the key switch no. 2 is in the “Auto” position.

The status of the pressure switches is signalled by a green or yellow LED (Fig. 2, pos. 34, 35).

In the event of a cable cut or connection malfunction of one of the 2 pressure switches, a red LED is activated (Fig. 2, pos. 36, 37). This malfunction causes the diesel motor to start up automatically.

In automatic mode, the diesel motor also starts up if the level of the start-up tank is less than 2/3 full. The motor only stops through the intervention of a technician.

### **Automatic start-up process**

The automatic start-up consists of a sequence of six consecutive start-up attempts. Each attempt lasts 15 seconds and is followed by a pause of 10 to 15 seconds. After each start-up attempt, the other battery is used for the following attempt. Even if there is no additional need on the float or key switch level, start-up attempts continue. The number of attempts with each battery will be constantly indicated on the LCD.

All successful start-ups are signalled by a green LED (Fig. 2, pos. 3) and the output “running” is activated. After six unsuccessful start-up attempts, an alarm signal is emitted, the output “failure to start” is activated and the red “failure to start” LED is turned on (Fig. 2, pos. 5) as well as the yellow LED which signifies “attempt at manual start-up” (Fig. 2, pos. 22) (see test of start-up device 6.2.1).

After a successful start-up sequence or after a phase of “failure to start”, the yellow LED named “Operate the test button for manual start-up if the indicator light is turned on” is turned on. (see device start-up test 6.2.1).

### **Non-automatic mode**

The key switch is not in the “Auto” position. Consequently, the corresponding pressure switch cannot activate automatic start-up.

If neither of the two key switches is in the “Auto” position, then the start-up tank also cannot activate automatic start-up. This operating mode is signalled by the red LEDs (Fig. 2, pos. 32, 33). Furthermore, the output “NON-AUTO MODE 1/2” is active.

### **Manual mode**

To perform a manual start-up, place one of the key switches in the “Man” position. The manual start-up (like the automatic start-up) consists of a sequence of six consecutive start-up attempts. Each attempt lasts 15 seconds and is followed by a pause of 10 to 15 seconds. After each start-up attempt, the other battery is used for the following attempt.

Even when the key switch is not in the “Man” position, the start-up attempts continue.

### **Deactivation mode**

To switch off the diesel motor, at least one of the key switches must be in the “0” position. As soon as the pressure switch (or the float switch) is no longer activated, the diesel motor can be switched off by means of the “OFF” button (Fig. 2, pos. 21).

### **Emergency start**

Start by lifting the emergency start button protection cap (Fig. 1, pos. 12 et 13).

Subsequently, to start the diesel motor with battery no. 1, press the button “battery 1 emergency start”, and keep the button pressed until start-up.

To start the diesel motor with battery no. 2, press the button “battery 2 emergency start”. In this start-up mode, the starter is fed directly from the batteries.

### **Manual start-up device test**

After a start-up sequence (manual or automatic) or after a failure to start, the yellow LED (Fig. 2, pos. 22) recognised by the following indication is turned on: “OPERATE THE MANUAL START TEST BUTTON IF THE INDICATOR LIGHT IS TURNED ON”.

In this case, the corresponding button must be pressed (Fig. 2, pos. 23) to perform the start-up device test.

## Pump demand

If the set pressure configured is not reached for at least one of the two pressure on/off switches, the green or yellow LED signals this (Fig. 2, pos. 34, 35). If these LEDs flash, this signifies that a configured dwell time has elapsed (see menu 1.2.5.1). Once the set dwell time has elapsed, the corresponding LED remains turned on while the pressure switch is activated. The automatic start-up test run of the diesel motor is launched with a maximum of 6 start-up attempts. The running-in period (menu 1.2.2.1) as well as the pause time (menu 1.2.2.2) can be set using the software. After each start-up attempt, a switch to the other battery takes place. Any non-coupled pinions in the ring gear of the motor are detected. Connection is achieved by means of additional attempts.

Successful start-up of the diesel motor is signalled by the green LED (Fig. 2, pos. 3). This lights up when the measured rotation speed exceeds the threshold of the cut-in adjusted for "motor in operation" (menu 1.2.1.3). The LCD displays the symbol of the pump and the battery currently being charged with the remaining time before passing to the next charging system. The pinion for engaged starter is automatically disengaged. The diesel motor can only be manually switched off with the "OFF" button (Fig. 2, pos. 21), if at least one of the key switches is in the "Stop" position and if the change-over switch is not engaged. The green LED (Fig. 2, pos. 3) turns off if the cut-in threshold for "motor in operation" is not reached. The LCD displays once more the remaining time until passing to the other charging system.

## Filling device

If the start-up tank level falls below 2/3 of its full level, then the "START-UP TANK MALFUNCTION" LED (Fig. 2, pos. 12) is activated.

If the LED flashes, this signifies that a follow-up time is elapsing (see menu 1.2.5.2). Once the set follow-up time has elapsed, the LED remains turned on while the float switch is activated.

This detection of a lack of water in the start-up tank launches the automatic start-up sequence of the diesel motor, with a maximum of 6 start-up attempts. The running-in period (menu 1.2.2.1) as well as the time between 2 attempts (menu 1.2.2.2) can be adjusted. After each start-up attempt, a switch to the other battery takes place. Any non-coupled pinions in the ring gear of the motor are detected.

A successful start-up of the diesel motor is signalled by a green LED (Fig. 2, pos. 3). This lights up when the measured rotation speed exceeds the threshold of the cut-in adjusted for "motor in operation" (menu 1.2.1.3). The LCD displays the symbol of the pump and the battery being charged with the remaining time before passing to the next charging system. The diesel motor can be manually switched off with the "OFF" button (Fig. 2, pos. 21), if at least one of the key switches is in the "Off" position and if the float switch is not engaged. The green LED (Fig. 2, pos. 3) turns off if the cut-in threshold for "motor in operation" is not reached. The LCD displays the remaining time before passing to the next charging system.

## Monitoring of battery voltage

The cabinet is fitted with two battery chargers which are fed by the 230 V AC network.

The chargers deliver 12 V DC or 24 V DC, depending on the type of starter to be fed.

To maintain continuous service, the network voltage as well as the battery charges are constantly monitored.

Battery monitoring is ensured by the controller which constantly receives information from the two chargers.

The chargers can signal the following malfunctions to the controller:

- a rupture of the wire, coupling or connection,
- a short-circuit,
- a battery malfunction,
- a connection voltage error.

The malfunctions are analysed by the controller and displayed in the malfunction menu (Fig. 1, pos. 2).

Furthermore, it is possible to adjust the minimal battery voltage in the menu 5.4.1.0. If this voltage is not achieved by one of the connected batteries, an error message is displayed on the screen.

## Monitoring of motor start-up

Once the pressure switch/float switch is activated, or after a successful manual start-up, the automatic start-up cycle of the motor is launched.

During the start-up phase, the controller monitors to ensure that the diesel motor is triggered.

The diesel motor is triggered when the start-up pinion is engaged in the gear ring of the motor.

If the diesel motor is not triggered after the first attempt, an error message appears on the screen. After each start-up attempt, the other battery is used for the following attempt. After 6 unsuccessful start-up attempts, the process is interrupted, the yellow LED "ATTEMPT START-UP" turns on (Fig. 2, pos. 22), an error message is displayed on the screen and the malfunction signal contacts are active.

## Duty cycling of the battery chargers

From the menu 5.3.1.0, it is possible to force the duty cycling of the active charger.

To do this, go to the menu 5.3.1.0, accessible from level 3, change the value "Auto" and select "Man". The value automatically reverts to "Auto".

The battery charger which was active has swapped. The duty cycling countdown has also been reset to 0.

## 6.2.2 Application of the switchgear

### Levels of access

- **Level of access 1:** Allows access to the functions without particular restrictions, such as for stopping the buzzer (Fig. 2, pos. 18) or to proceed to a light test (Fig. 2 pos. 19).
- **Level of access 2,** intended for operators/owners, is accessible only after activation of the key switch (Fig. 1, pos. 6). It enables access to certain functions such as the resetting of error messages (Fig. 2, pos. 20) and the commissioning/decommissioning of the pre-heating diesel device (Fig. 2, pos. 17).
- **Level of access 3,** intended for the commissioner, is accessible with a code, given in the menu 7.0.0.0. It enables access to all configurations of the menu.

### Control elements

- Main switch (Fig. 1, pos. 11) On/Off (lockable in "Off" position).
- The LCD (Fig. 1, pos. 2) displays the pump operating status and the settings menu. The control button (Fig. 1, pos. 3) allows menu selection and the entering of parameters (level 3 access required). To modify the values or to scroll through a menu level, turn the knob and to select and confirm, press it:

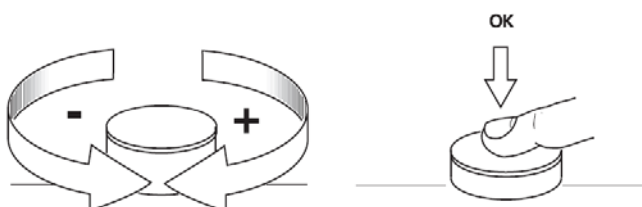



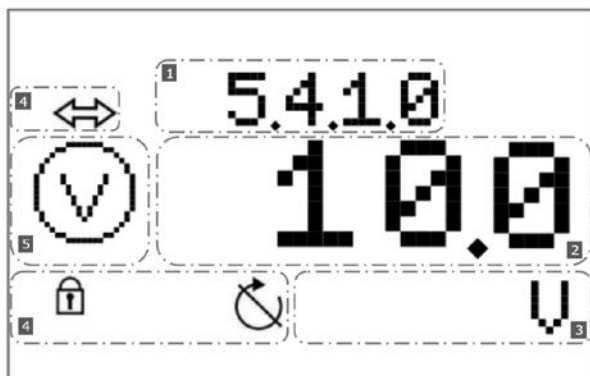























The information display is performed on the screen according to the following model:





















Pos.	Description
1	Menu number
2	Value display (text)
3	Unit display (text)
4	Standard symbols
5	Graphic symbols













The following graphic symbols are used:

Symbol	Function/description	Availability
	Return (brief press: a menu level; long press: main screen)	All
	EXPERT menu	All
	1. Notification: not connected 2. Notification: display value – no entry possible	All
	Active/unlocked	
	Service menu	All
	Parameters	All
	Information	All
	Malfunction	All
	Reset malfunction	All

	Alarm settings	All
	Pump	All
	Setpoint	All
	Actual value	All
	Sensor signal	All
	Measurement sensor range	Electric
	Follow-up time	All
	Operating mode/application	All
	Stand-by	All
	Operational data	All
	Switchgear data: Controller type; ID number; software/firmware	All
	Operating hours	All
	Pump operating hours	All
	Switchgear operating cycles	All
	Pump operating cycles	All
	Communication	All
	Output parameters	All
	SSM parameters	All



	Definition of the motor rotation speed	Diesel
	Running-in period via start-up attempt	Diesel
	Pause between start-up attempts	Diesel
	Fuel	Diesel
	Battery 1 (A)	Diesel
	Battery 2 (B)	Diesel
	Sprinkler (pressure switch)	All
	Pump filling tank (float switch)	All
	Heating	Diesel
	Motor oil	Diesel
	Thermostat temperature of the motor	Diesel
	(Temperature of the water) for cooling	Diesel
	Belt rupture	Diesel
	Start-up interruption	Electric
	Pressure	Electric
	Power supply (mains)	Electric
	Voltmeter	All
	Ammeter	All
	Cut-in star-delta	Electric

	Malfunction signal freely configurable	All
	Malfunction input	All
	Start-up attempts counter	Diesel
	Duration	All
	Power indicator	Electric
	Communication parameters	All
	Modbus	All
	BACnet	All
	Factory setting	All
	Reset to the factory setting	All
	Alarm counter	All
	Maintenance interval	All
	Reset	All
	Motor rotation speed	Diesel
	Definition of the motor rotation speed	Diesel
	Minimum rotation speed for the signal "motor in operation"	Diesel
	Start-up counter reset	Diesel
	Manual	Diesel
	Commissioning	Diesel





**Menu structure:**

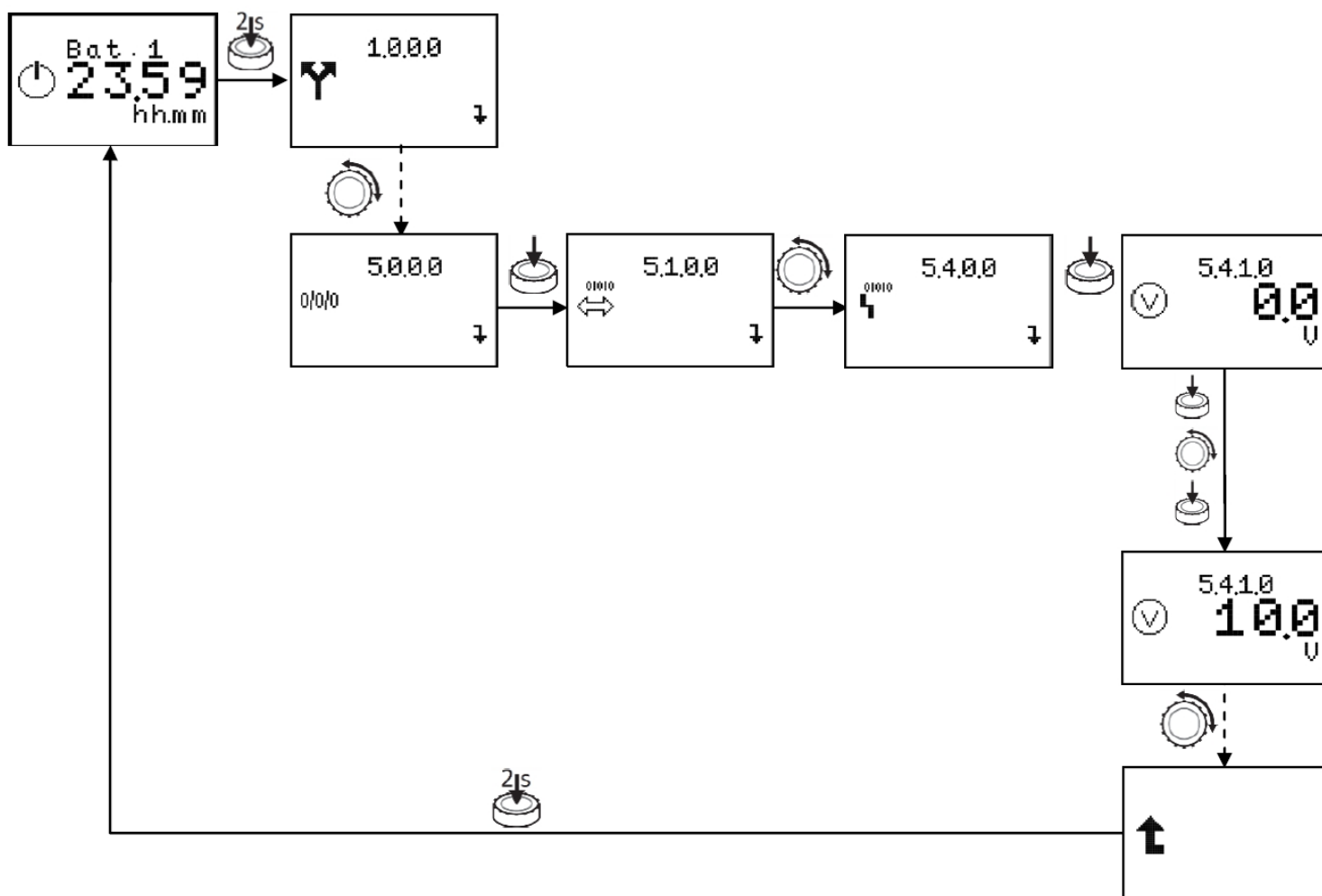





The menu structure of the control system has 4 levels.



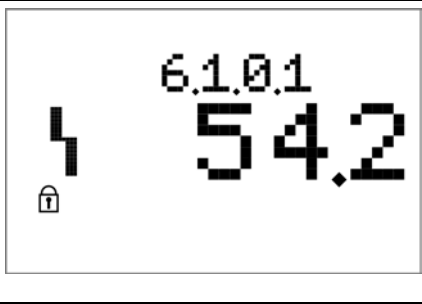

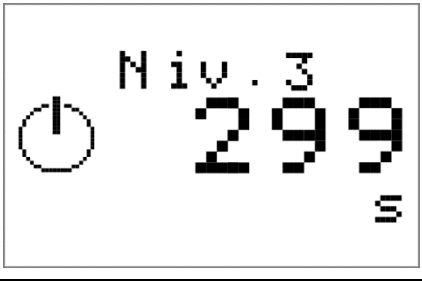
Navigation in the individual menus as well as the parameter input are described in the example of the modification of the minimum battery voltage (level of access 3 required):





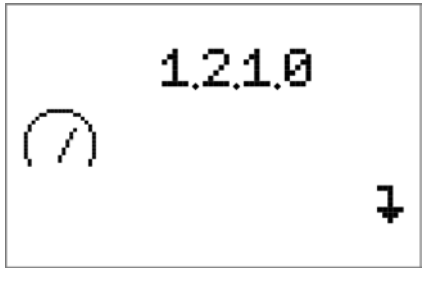

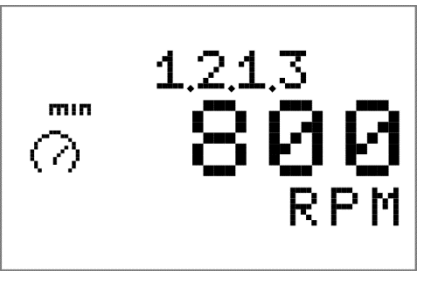





Refer to the following table for a description of the individual menu items.

Menu no.	1.1.1.1 Screen	1.1.2 Description	Parameter range <b>Factory setting</b>
Menu accessible from the level of access no. 1			
		The main screen displays the battery currently being charged and the remaining time before switching to the other battery charger [hh.mm].	
		When the motor is running, the pump symbol appears on the screen (in the place of the stand-by symbol) on the main screens.	
		"Services" menu	
		To access level 3 an access code must be entered. After 5 minutes of inactivity on HMI or after a main supply malfunction, access is blocked and the code must be re-entered.	0...9999
		"Malfunctions" menu	

6.1.0.1 to 6.1.1.6		History memory of malfunctions from 1 to 16  Remarks: The history memory of malfunctions and the error counter can be reset via the menu 7599 accessible on level 3.	
Menu accessible from the level of access no. 3			
		The main screen displays the battery currently being charged and the remaining time before switching to the other battery charger [hh.mm].	
		The remaining time [in secs] before deactivation of the level of access 3 in case of inactivity on the HMI is also indicated on the main screen (alternating every 5 seconds with the previous screen).	
		On the main screen, and when the motor is running, the pump symbol appears in the place of the stand-by symbol.	
		Menu unlocked with the correct access code	
		The EXPERT menu contains other settings which enable a detailed configuration of the switchgear.	

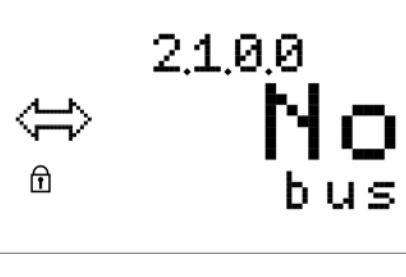
		Access to the parameter menu enabling modification of the system operation.	
		The settings menu for the parameters of rotation speed.	
		<p>Settings of the motor rotation speed:</p> <p>When the diesel motor is running, and with the aid of a tachometer, (not provided), the actual speed must be entered in order to set parameters for the controller.</p>	100 ... <b>3000</b> ... 4000
		Once the preceding action has finished, validate the procedure by selecting "start" from the menu, which will automatically return to "finished".	<b>Finished</b> Start
		Minimum rotation speed from which the controller deems that the "motor is in operation".	200 ... <b>800</b> ... 3000
		The parameter menu for all timer parameters influencing the operation.	



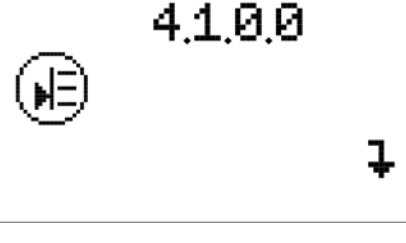

	 <p>1.2.2.1 <b>15</b> s</p>	Duration of each motor start-up attempt	5 ... <b>15</b>
	 <p>1.2.2.2 <b>10</b> s</p>	Pause duration between two start-up attempts	5 ... <b>10</b> ... 15
	 <p>1.2.5.0 ↓</p>	Delays	
	 <p>1.2.5.1 <b>1</b> s</p>	Start-up delay in case of pressure switch activation	<b>1</b> ... 10
	 <p>1.2.5.2 <b>1</b> s</p>	Start-up delay in case of float switch activation	<b>1</b> ... 10
	 <p>1.2.5.3 <b>3</b> s</p>	Activation delay from the malfunction "Empty fuel tank"	0 ... <b>3</b> ... 5

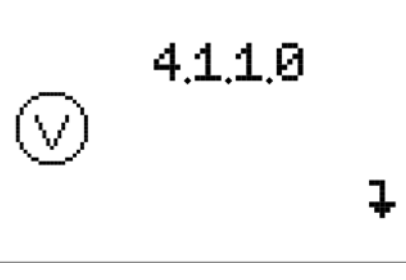
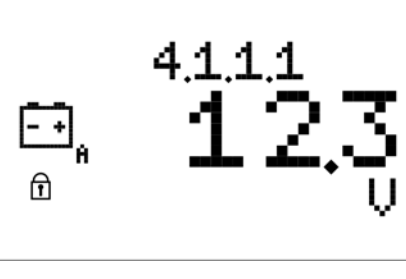
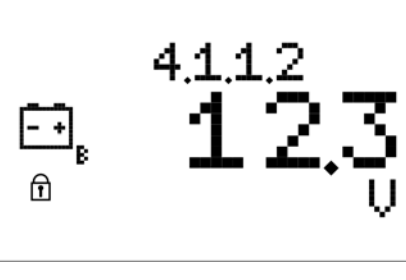
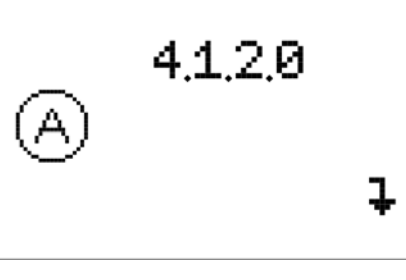
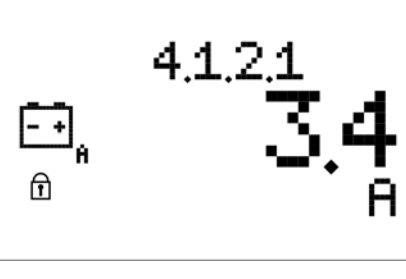
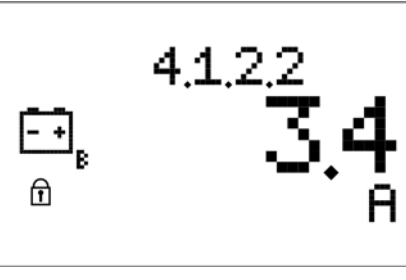
		Communication	
		Display of active communication bus	<b>No bus (no active bus),</b> Modbus, BACnet
		Pump menu	
		Display of the automatic mode status: ON or OFF  Remarks: This information is the image of the change-over switch status on the front of the cabinet.	
		Information menu	
		Service parameters	

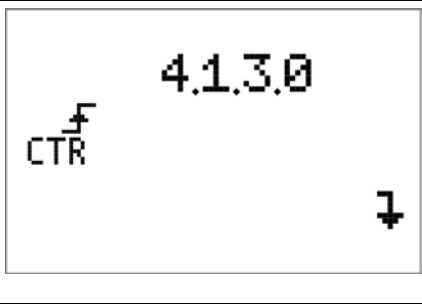
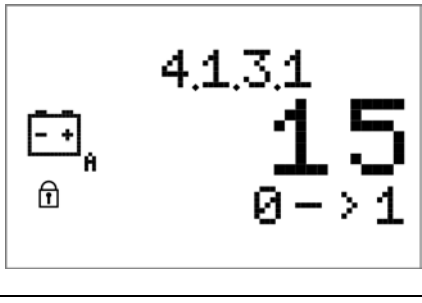
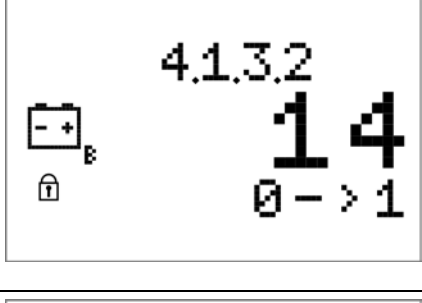
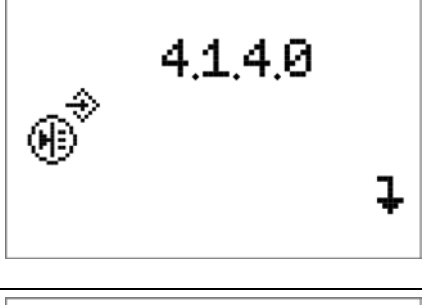
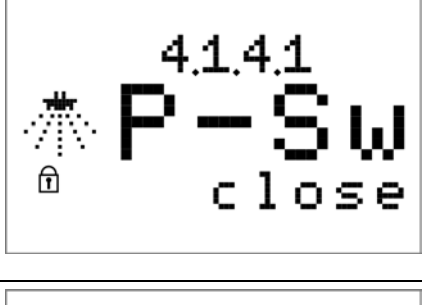
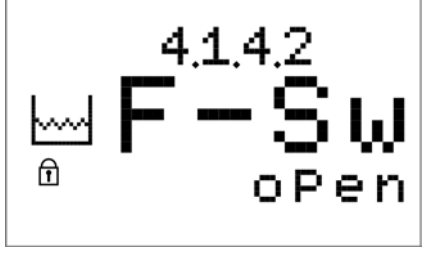

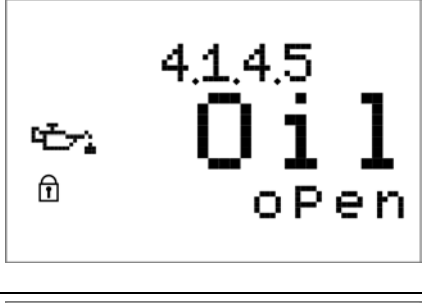

	 <p>4.1.1.0 V ↓</p>	Battery voltage	
	 <p>4.1.1.1 12.3 V</p>	Instantaneous voltage battery A	
	 <p>4.1.1.2 12.3 V</p>	Instantaneous voltage battery B	
	 <p>4.1.2.0 A ↓</p>	Load currents	
	 <p>4.1.2.1 3.4 A</p>	Instantaneous load current battery A	
	 <p>4.1.2.2 3.4 A</p>	Instantaneous load current battery B	

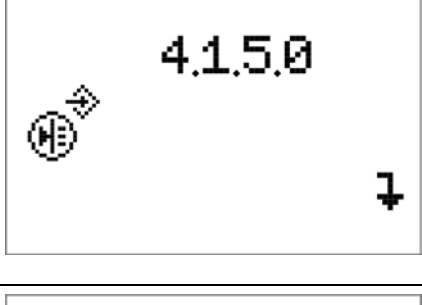
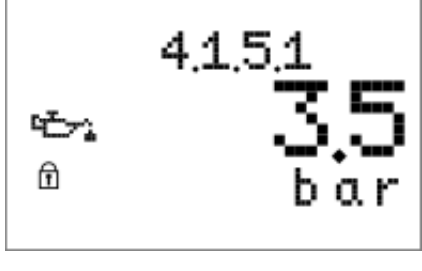

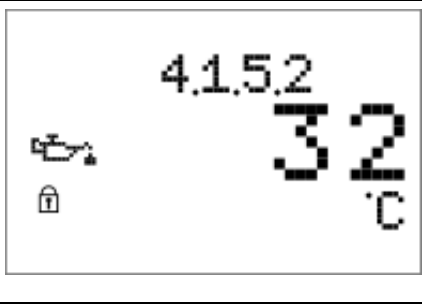
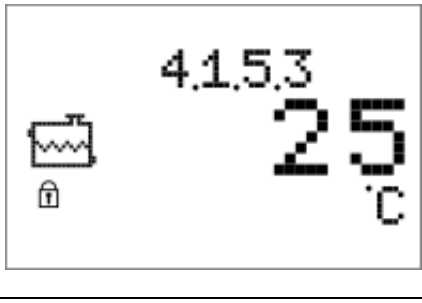
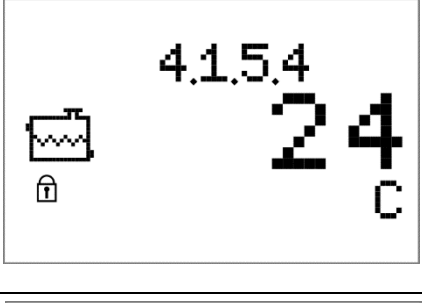
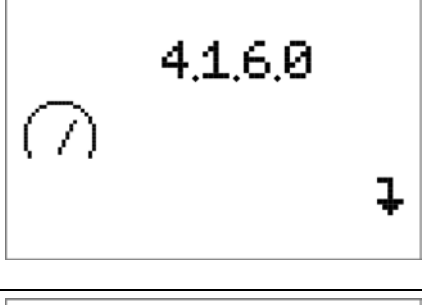
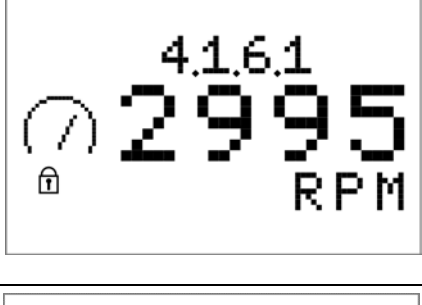
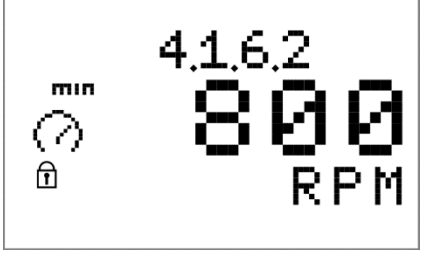
	 <p>4.1.3.0 CTR ↓</p>	Counter for start-up attempts of the diesel motor	
	 <p>4.1.3.1 15 0 - &gt; 1</p>	Total start-up attempt counter from battery A	
	 <p>4.1.3.2 14 0 - &gt; 1</p>	Total start-up attempt counter from battery B	
	 <p>4.1.4.0 ↓</p>	Status of sensors	
	 <p>4.1.4.1 P-Sw close</p>	Status of pressure switch Contact open Or Contact closed	
	 <p>4.1.4.2 F-Sw open</p>	Status of start-up tank float switch (low level) Contact open Or Contact closed	

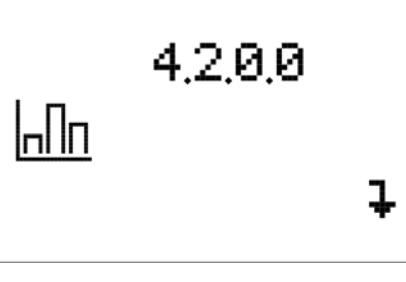
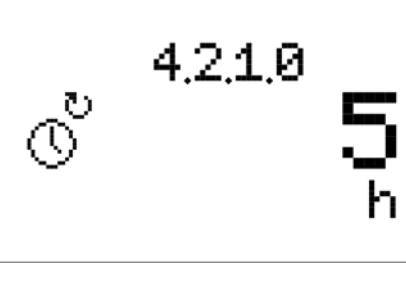
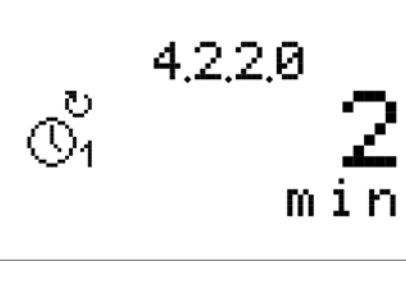
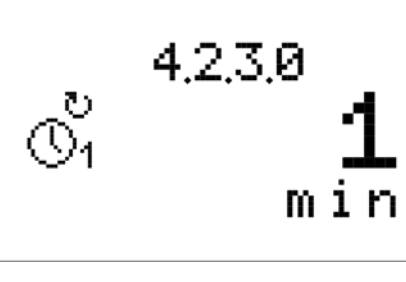
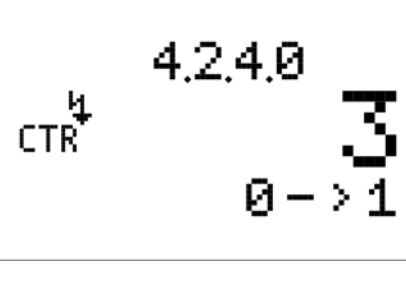
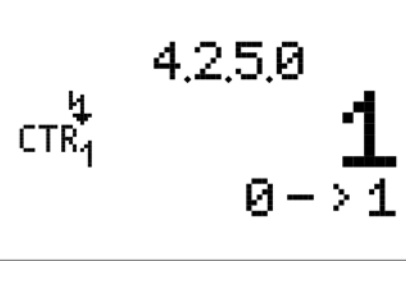

	 <p>4.1.4.3 Fuel open</p>	<p>Status of float switch in the fuel tank (low level)</p> <p>Contact open Or Contact closed</p>	
	 <p>4.1.4.4 Heat open</p>	<p>Status of thermo contact of the diesel pre-heating device</p> <p>Contact open Or Contact closed</p>	
	 <p>4.1.4.5 Oil open</p>	<p>Status of the thermo contact of the diesel oil</p> <p>Contact open Or Contact closed</p>	
	 <p>4.1.4.6 Temp open</p>	<p>Status of the thermo contact of the cooling water of the diesel motor</p> <p>Contact open Or Contact closed</p>	
	 <p>4.1.5.0</p>	<p>Values of the sensors</p>	
	 <p>4.1.5.1 3.5 bar</p>	<p>Display of the oil pressure</p> <p>Remarks: At menu 5250 this sensor is deactivated as not installed in the system.</p>	

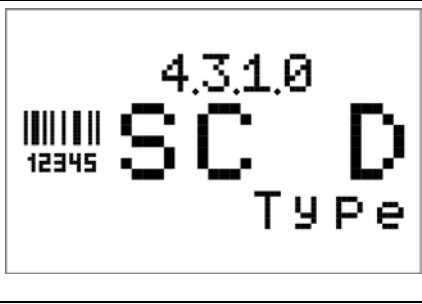
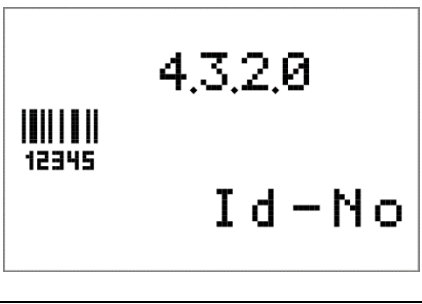
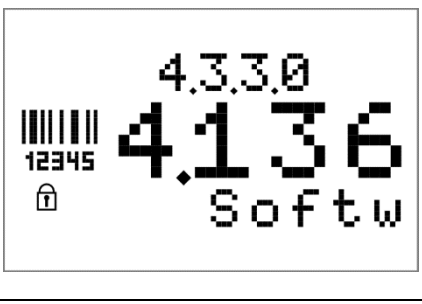
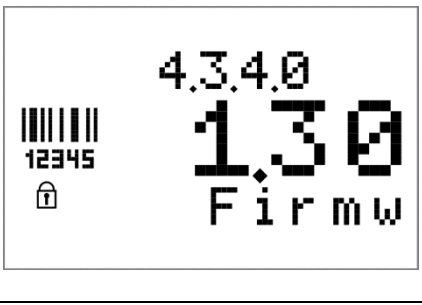
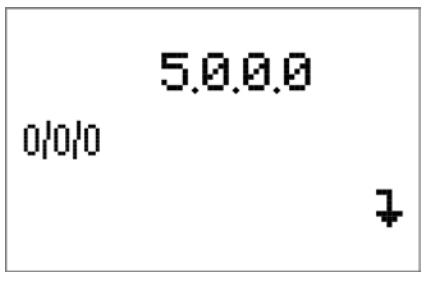
		<p>Oil temperature</p> <p>Remarks: At menu 5260 this sensor is deactivated as not installed in the system.</p>	
		<p>Temperature of the cooling water</p> <p>Remarks: This sensor is not installed in the system.</p>	
		<p>Temperature of the cooling water (external)</p> <p>Remarks: This sensor is not installed in the system.</p>	
		<p>Rotation speed menu</p>	
		<p>Display of instantaneous rotation speed of the diesel motor</p>	
		<p>Display of the minimum rotation speed to deem that the "motor is in operation"</p>	

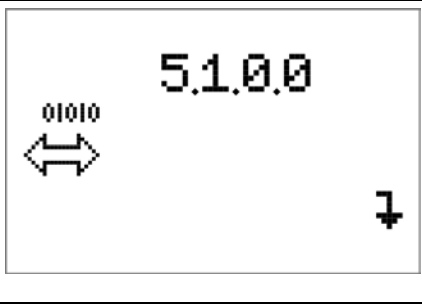
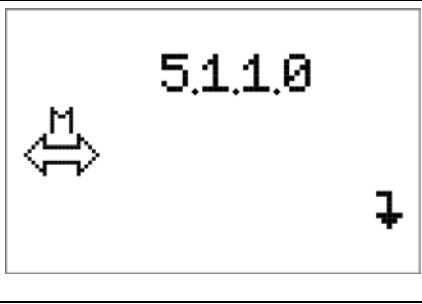
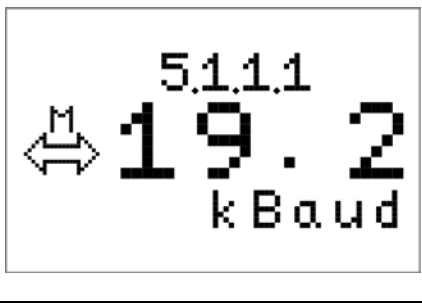
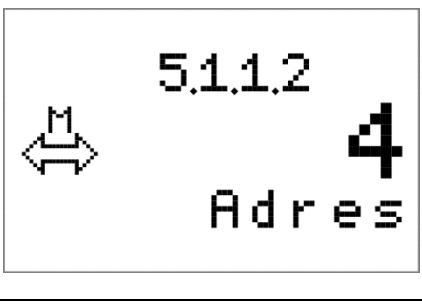

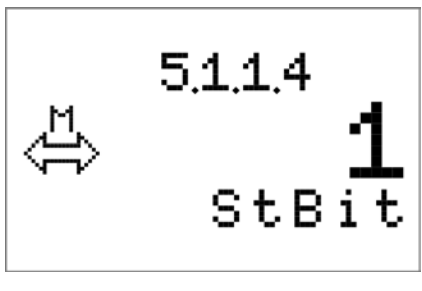
		Operational data	
		Total hour counter of operation of the SC-FIRE Diesel cabinet	
		Total hour counter of operation of the diesel motor	
		Total hour counter of operation of the diesel motor since the last start-up	
		Number counter of cabinet power ups  Remarks: Activation of the main switch or connection of batteries	
		Number counter of pump start-ups	

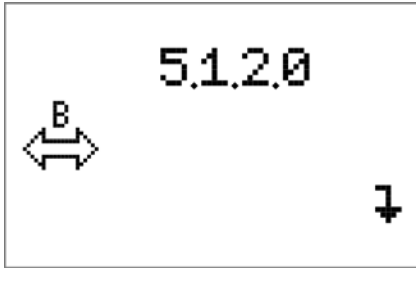
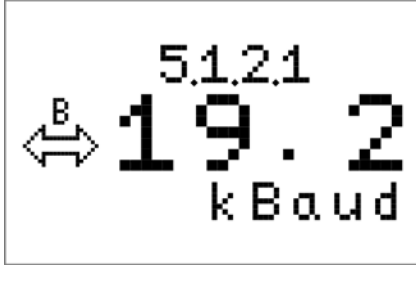
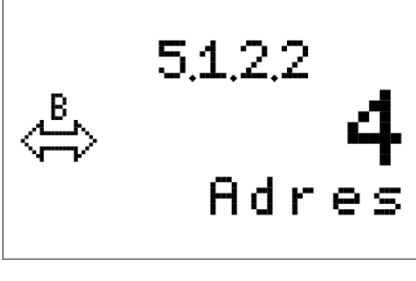

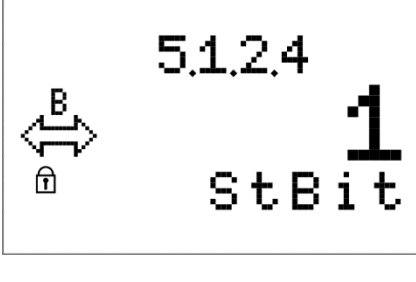
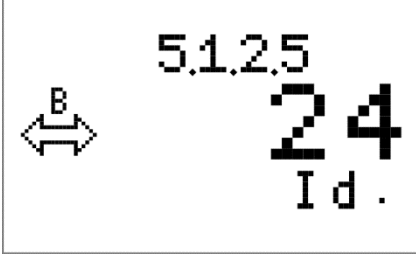

	 <p>4.3.0.0 12345 →</p>	System characteristics	
	 <p>4.3.1.0 12345 SC D Type</p>	System type	SC Diesel APSAD
	 <p>4.3.2.0 12345 Id-No</p>	Serial number display Remarks: Text scrolling	
	 <p>4.3.3.0 12345 4.136 Softw</p>	Software version display	
	 <p>4.3.4.0 12345 1.30 Firmw</p>	Firmware version display	
	 <p>5.0.0.0 0/0/0 →</p>	Adjustments	

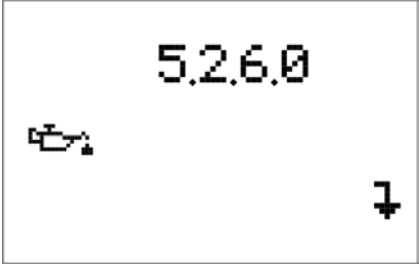
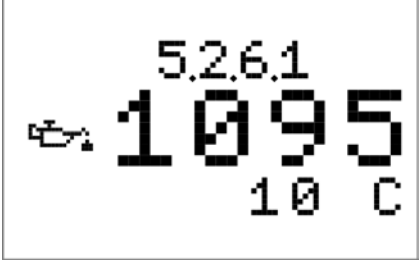
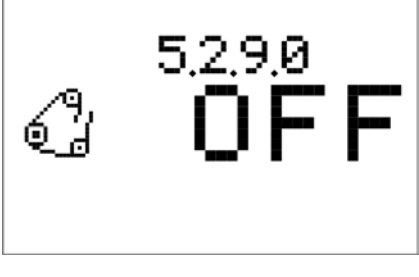
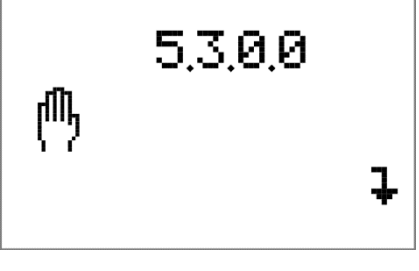

	 <p>5.1.0.0</p>	Communication	
	 <p>5.1.1.0</p>	Modbus	
	 <p>5.1.1.1 19.2 kBaud</p>	Baud delivery rate	9.6 <b>19.2</b> 38.4 76.8
	 <p>5.1.1.2 4 Adres</p>	Slave address	1 ... 4 ... 247
	 <p>5.1.1.3 even Parit</p>	Parity	<b>Even</b> No (none) Odd
	 <p>5.1.1.4 1 StBit</p>	Stop bits	<b>1</b> 2

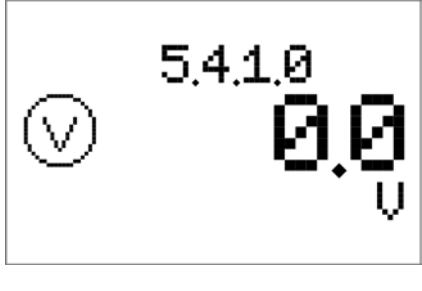
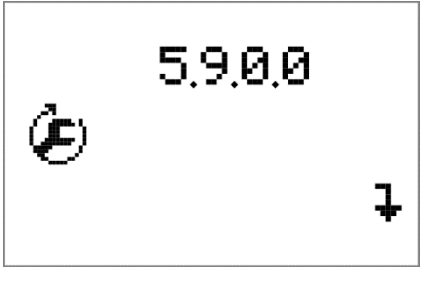

	 <p>5.1.2.0 ↔<sup>B</sup> ↓</p>	BACnet	
	 <p>5.1.2.1 ↔<sup>B</sup> 19.2 kBaud</p>	Baud delivery rate	9.6 <b>19.2</b> 38.4 76.8
	 <p>5.1.2.2 ↔<sup>B</sup> 4 Adres</p>	Slave address	1 ... <b>4</b> ... 255
	 <p>5.1.2.3 ↔<sup>B</sup> 🔒 none Parit</p>	Parity	Even <b>No (none)</b> Odd
	 <p>5.1.2.4 ↔<sup>B</sup> 🔒 1 StBit</p>	Stop bits	<b>1</b> 2
	 <p>5.1.2.5 ↔<sup>B</sup> 24 Id.</p>	BACnet Device Instance ID	0 ... <b>24</b> ... 9999



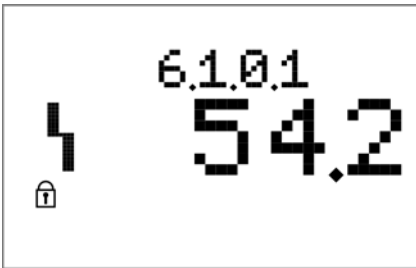

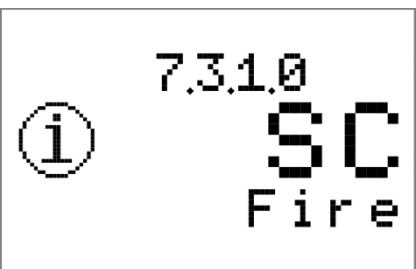
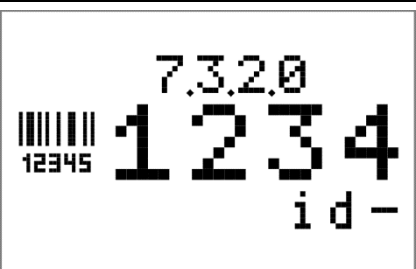

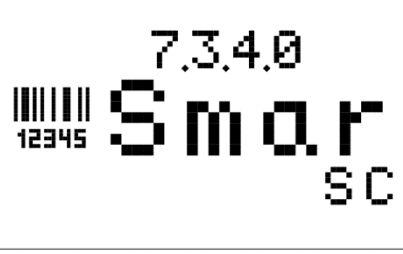
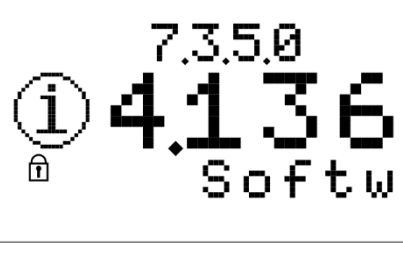
		Adjustments of the sensors	
		Oil pressure sensor activation	<b>OFF</b> <b>ON</b>
		Correspondence values for the oil temperature sensor	
5.2.6.1 to 5.2.6.9		Input of resistance values for a temperature of 10 °C  Remarks: The adjustment of the resistance profile continues in the menus 5.2.6.2 to 5.2.6.9.	0 ... 3000 (in ohms)
		Activation of the monitoring of belt failure	<b>OFF</b> <b>ON</b>
		Forced cut-in of battery charger	

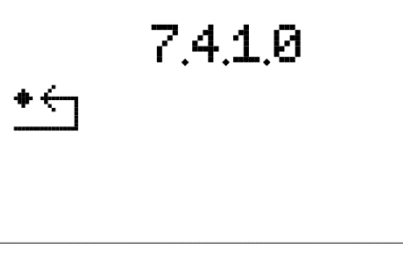
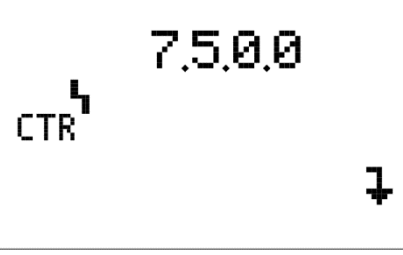
		<p>Immediate duty cycling of active charger</p> <p>Remarks: By selecting the parameter "Man", the battery charger currently active is reversed. And the countdown before duty cycling is reset to 0, visible on the main screen.</p>	<p><b>Auto</b> <b>Man</b></p>
		<p>Limit values</p>	
		<p>Minimum battery voltage</p>	<p><b>0 ... 30</b></p>
		<p>Control of the commissioning</p>	
		<p>Control of the commissioning start-up</p> <p>Remarks: Menu dedicated to the commissioner.</p>	<p><b>Finished, Start</b></p>
		<p>Malfunction messages</p>	

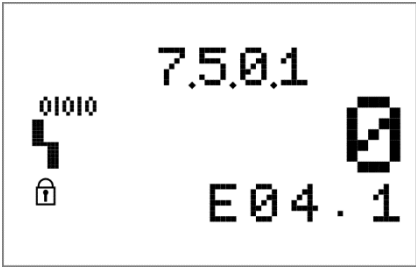
		<p>Resetting of malfunction messages</p> <p>This menu is equivalent to the reset button malfunction on the front of the cabinet.</p>	
6.1.0.1 to 6.1.1.6		<p>History memory of malfunctions from 1 to 16</p>	
		<p>Services menu</p>	
		<p>Access to the parameterisation of the cabinet</p>	
		<p>Designation of the cabinet</p>	
		<p>Adjustment of the serial number: Adjustment of the first 4 numbers of the serial number</p> <p>These numbers are adjusted in the factory and cannot be modified.</p>	0...9999

		<p>Adjustment of the serial number: Adjustment of the last 4 numbers of the serial number</p> <p>These numbers are adjusted in the factory and cannot be modified.</p>	0...9999
		Controller designation	
		Software version display	
		<p>Factory setting menu: Possibility to reset the cabinet to factory configuration</p>	
		<p>Restoring of factory parameters: By pressing the red button, the symbol "factory" flashes, turn the red button to the right, the symbol "reverse arrow" appears, press the button a second time to launch the resetting of the cabinet to factory configuration.</p>	
		Alarm menu	

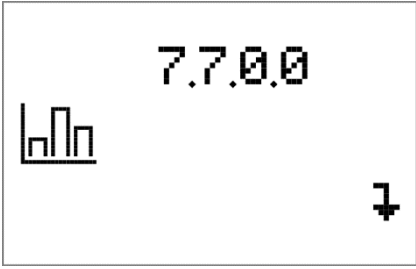
		<p>Error counter display, showing the number of times that the error Exx.x has occurred. Scroll through the error codes with the red button.</p>	
		<p>Resetting of the malfunction history and error counter: By pressing the red button, the symbol flashes, turn the red button to the right, press the button a second time.</p> <p>The malfunction history and the error counter are now reset.</p>	
		<p>Additional menu functions</p>	
		<p>Activation code: Enter the activation code, for example, to activate a field bus connection.</p>	
		<p>Modification of access code to level 3: To reset the access code, please call the technical service.</p>	
		<p>Operational data of the menu reset</p>	

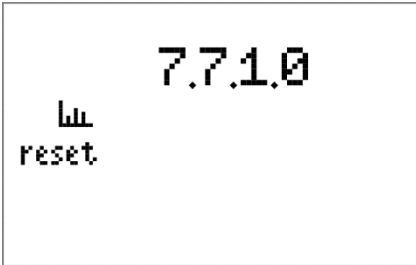
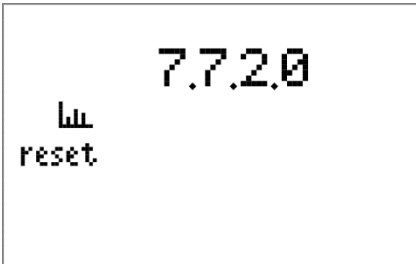
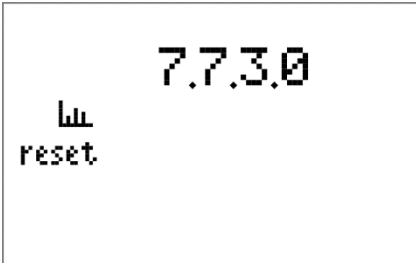
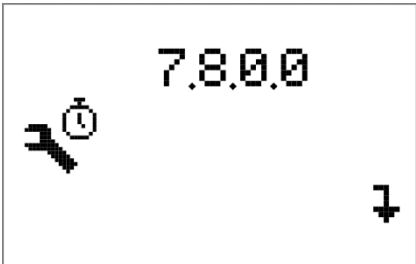
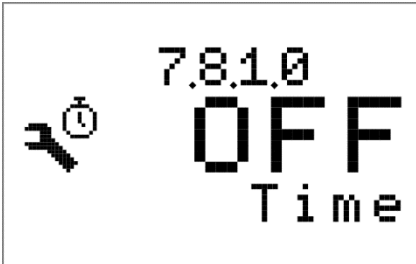
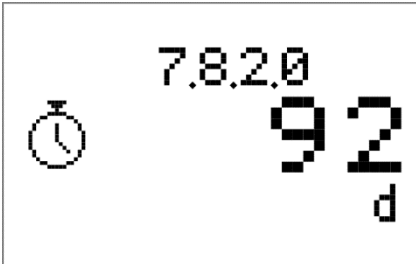
		<p>Resetting to zero of the total hour counter of pump operation time and start-up number counter: By pressing the red button, the symbol flashes, then press the button a second time.</p>	
		<p>Resetting to zero of the total hour counter of operation time of battery 1</p>	
		<p>Resetting to zero of the total hour counter of operation time of battery 2</p>	
		<p>Maintenance and repair menu</p>	
		<p>Activation/deactivation of the maintenance interval OFF Or ON</p>	
		<p>Adjustment of the duration in days for the maintenance interval</p>	<p>0...<b>92</b>...1000</p>

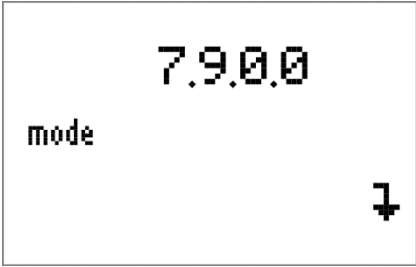
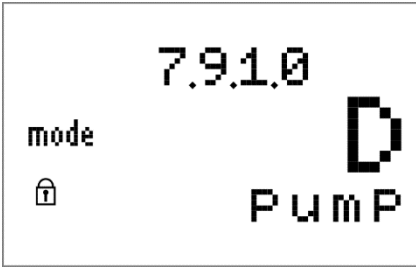
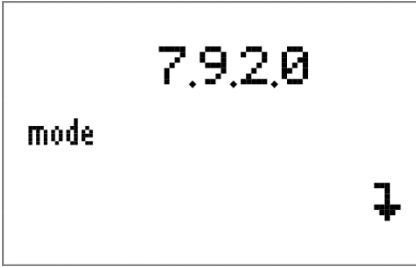
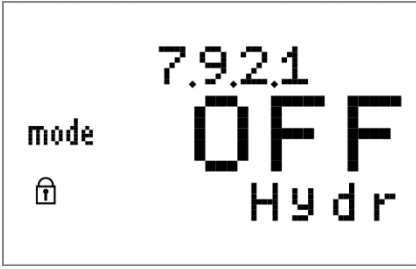
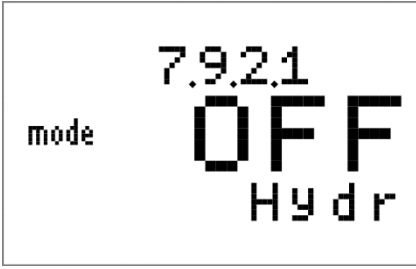
		<p>Resetting to zero of the maintenance message:</p> <p>By pressing the red button, it is possible to reset the maintenance countdown</p>	
		<p>Application menu</p>	
		<p>Diesel mode display</p>	
		<p>RIA menu</p>	
		<p>Activation/deactivation of the RIA application:</p> <p>Protected access: To gain access, please call the technical service.</p>	
		<p>Activation/deactivation of the application of the hydrants:</p> <p>Once access has been granted by the technical service.</p>	

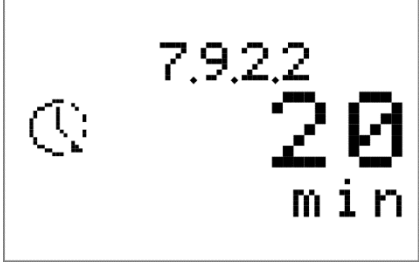
		Adjust the time in minutes for the automatic stop of the pump.	1...20
--	---	--	--------

### Operation levels:

#### Levels of use:

The parameterisation of the switchgear is divided into the menu areas EASY and EXPERT. Access to level 1 allows consultation of the breakdown history in the menu level 6.0.0.0 and the identification/connection sector from menu 7.0.0.0. Access to level 3 allows consultation and parameterisation of the whole menu.

For rapid commissioning using the factory presets, it is enough to set the speed values and the speed adjustment in the EASY area.

- **Key switch (Fig. 1, pos. 48 et 49)**

Pressure switch 1 and pressure switch 2 each have a key switch. The key switches can be locked in the “Auto” position and their keys can only be withdrawn if the key switches are in the “Auto” position. Once the “0” or “Manual” position has been selected, no automatic start-up with the pressure switch or float switch can take place. The status corresponding to the “Auto” position is signalled by the green LEDs (Fig. 2, pos. 30, 31) and that which corresponds to the “0” or “Manual” position by the red LEDs (Fig. 2, pos. 32, 33).

If you turn one of the key switches in “Manual” mode, the diesel motor starts up manually with battery 1 or 2, and six attempts maximum.

- **Key switch (Fig. 1, pos. 6)**

By turning the key switch into the “On” position, you will access the level 2 functions.

- **Change-over switch (Fig. 1, pos. 7)**

The change-over switch enables selection of battery 1 or 2. For the chosen battery, the voltage and current are displayed on the screen (Fig. 1, pos. 4, 5).

- **Emergency start button (Fig. 1, pos. 12, 13)**

This button allows you to manually start the diesel motor with the corresponding battery and without intervention of the control.

- **“PRE-HEATING ON/OFF” (Fig. 2, pos. 17)**

The heating ensuring a constant temperature of the motor oil turns on automatically as soon as the system is powered up. This button enables the heating to be switched off and restarted (Level of access 2 required). Once the heating is switched off, this malfunction is signalled by a red LED (Fig. 2, pos. 8) and a buzzer signal.

- **“BUZZER OFF” (Fig. 2, pos. 18)**

This button allows an audible signal emitted in case of alarm to be cleared separately (level of access 1 required). As soon as a new malfunction arises, the buzzer signal sounds once again.



- **“LAMP TEST” (Fig. 2, pos. 19)**

If you press this button (level of access 1 required), all the control lamps and the alarm buzzer turn on for the duration of the actuation, which allows you to check their good functioning. Once the button is released, the control lamps and the alarm buzzer turn off once again or remain turned on only if the functioning demands it.

- **“CLEAR MALFUNCTION” (Fig. 2, pos. 20)**

By pressing the button (level of access 2 required), all the error messages/control lamps are reset insofar as the cause of the error has been eliminated.

- **“OFF” (Fig. 2, pos. 21)**

This button serves to switch off the motor. To do this, at least one of the switches must be in the “0” position. The motor cannot be switched off if the pressure switch or float switch are not emitting anything. Once the motor is switched off, the control lamp “ON” turns off (Fig. 2, pos. 3).

- **“START-UP ATTEMPT BUTTON” (Fig. 2, pos. 23)**

This attempt button and its control lamp (Fig. 2, pos. 22) are intended for the manual and regular test of the electric start-up device. The button is used when an automatic motor start-up has taken place followed by a manual stop, and following six consecutive failed start-up attempts. For these two operation statuses, the control lamp turns on and the button must be pressed.

### 6.2.3 Display elements of the switchgear

#### “LIVE” (Fig. 2, pos. 1)

The control lamp turns on green as soon as the power supply is established.

#### “MAINS MALFUNCTION” (Fig. 2, pos. 2)

In case of malfunction in the level of connection voltage (charger, heating) or inactive switch, the LED turns on yellow with a follow-up time of 180 seconds.

#### “RUNNING” (Fig. 2, pos. 3)

The control lamp turns on green as soon as the diesel motor starts and when the rotation speed increased by the rotation speed sensor has reached or exceeded the value pre-set for “motor in operation” (menu 1.2.1.3).

#### “SYSTEM MALFUNCTION” (Fig.2, pos. 4)

The yellow LED signals a software malfunction if the communication between the “printed circuit board I/O” and the 2 printed circuit boards “SC controller” is interrupted or if the software routine (the programme) does not function correctly.

#### “START-UP FAILURE” (Fig. 2, pos. 5)

The control lamp turns on red following six consecutive failed start-up attempts.

#### “CLOGGING MALFUNCTION” (Fig. 2, pos. 6)

The measurement of the differential pressure at the filter level has detected a clogged filter. This malfunction is thus signalled by the LED turning on red.

#### “STARTER MALFUNCTION” (Fig. 2, pos. 7)

As soon as the switchgear no longer receives a response from the starter, the LED turns on red.

**“PREHEATING MALFUNCTION” (Fig. 2, pos. 8)**

The LED turns on red if the heating switches off or if the heating temperature switch or fuse is triggered.

**“OIL PRESSURE MALFUNCTION” (Fig. 2, pos. 9)**

The control lamp turns on red as soon as the oil pressure is detected to be too low by the automatic control of the oil pressure. This error message can only be transmitted during diesel motor operation.

**“WATER TANK LEVEL MALFUNCTION” (Fig. 2, pos. 10)**

If the water tank level is too low, this LED turns on red.

**“LACK OF MOTOR WATER MALFUNCTION” (Fig. 2, pos. 11)**

The level of the cooling water is monitored. If the level is too low, this LED turns on red.

**“START-UP TANK LEVEL MALFUNCTION” (Fig. 2, pos. 12)**

The control lamp flashes red as soon as the level of the pump filling tank corresponds to 2/3 of the tank and when the float switch is triggered. Once the start-up delay has elapsed (menu 1.2.5.2), the control lamp is permanently turned on red. If at least the key switch is in the “Auto” position, the diesel motor starts automatically.

**“WATER TEMPERATURE MALFUNCTION” (Fig. 2, pos. 13)**

The control lamp turns on red as soon as the temperature is detected to be too high by the connected thermostatic valve. This error message can only be transmitted during diesel motor operation.

**“VENT MALFUNCTION” (Fig. 2, pos. 14)**

Once the diesel motor starts up, the aeration valves must open within 10 seconds. If no signal is emitted after 10 seconds, the LED turns on red.

**“DIESEL LEVEL MALFUNCTION” (Fig. 2, pos. 15)**

The control lamp turns on red as soon as the float switch of the fuel tank is triggered.

**“ROOM TEMPERATURE MALFUNCTION” (Fig. 2, pos. 16)**

As soon as the room temperature drops below 10 °C, the control lamp turns on red.

**“START-UP ATTEMPT” (Fig. 2, pos. 22)**

The control lamp turns on yellow when an automatic start-up of the motor has been triggered by the pressure switch, followed by manual switch off, as well as after six consecutive failed start-up attempts.

**“BATTERY LOAD 1/2” (Fig. 2, pos. 24, 25)**

The two batteries are recharged alternately, every 24 hours. The corresponding green LED indicates the battery which is being recharged.

**“BATTERY MALFUNCTION 1/2” (Fig. 2, pos. 26, 27)**

The voltage of the batteries is monitored. Furthermore, any absence of short-circuit or line break is checked. As soon as a malfunction occurs, the LED turns on yellow.

**“BATTERY CHARGER 1/2 MALFUNCTION” (Fig. 2, pos. 28, 29)**

The connection voltage of the battery chargers is monitored. Furthermore, any absence of error or communication malfunction is checked. As soon as a malfunction occurs, the LED turns on yellow.

**“AUTO MODE 1/2” (Fig. 2, pos. 30, 31)**

The green LED turns on if the corresponding key switch is in the “Auto” position. In the automatic mode, the automatic start-up of the diesel motor is possible either via the intermediary of the float switch or the corresponding pressure switch.

**“NON-AUTO MODE 1/2” (Fig. 2, pos. 32, 33)**

The green LED turns on if the corresponding key switch is in the “0” or “Manual” position. In the non-automatic mode, no automatic start-up of the diesel motor is possible via the intermediary of the float switch or the corresponding pressure switch.

**“START-UP VIA PRESSURE SWITCH 1/2” (Fig. 2, pos. 34, 35)**

The control lamp flashes green as soon as the pressure of the unit drops below the set/requested pressure and when pressure switch 1 or 2 is triggered. Once the start-up delay has elapsed (menu 1.2.5.1), the control lamp is permanently turned on. If the pressure increases as a consequence, the control lamp turns off once again. If the key switch 1 or 2 is in the “Auto” position, the diesel motor starts automatically. If the pressure increases and the output button (Fig. 2, pos. 20) is activated (level of access 2 required), the indicator light turns back on.

**“PRESSURE SWITCH LINE 1/2 MALFUNCTION” (Fig. 2, pos. 36, 37)**

The connection of the pressure switches is monitored. Any short-circuit or cable rupture is signalled by the LED turning on red. If the corresponding key switch is in the “Auto” position, the diesel motor starts up automatically. Even in the absence of problems, the number of start-up attempts is limited to 6.

## 7 Installation and electrical connection

**Installation and electrical connection must be carried out in accordance with local regulations and only by qualified personnel!**



**WARNING! Risk of personal injury!**  
Comply with applicable accident prevention regulations.



**Warning! Danger of electric shock!**  
Danger from electrical current must be eliminated.  
Local directives or general directives [e.g. IEC] and instructions from local energy supply companies must be adhered to.

### 7.1 Installation

Install the switchgear/unit in a dry location.

Protect the place of installation from direct exposure to sunlight.

## 7.2 Electrical connection



### **DANGER! Risk of fatal injury!**

In case of non-compliant electrical connection, there is a danger of death by electrocution.

- Have the electrical connection established by an electrician approved by the local energy supply company only and in accordance with local regulations.
- Observe the installation- and operating instructions for the pumps and accessories.
- Disconnect the power supply before any work!



### **Warning! Danger of electric shock!**

There is a potentially fatal voltage on the supply side, even when the main switch is turned off.

- The type of mains, current type and voltage of the mains connection must match the details on the rating plate of the control device.



### **NOTE:**

- Fuse on mains side in accordance with the information in the wiring diagram.
- Feed the ends of the mains cable through the threaded cable connections and cable inputs and wire them according to the markings on the terminal strips.
- Earth the pump/system in accordance with the regulations.

### 7.2.1 Power supply connection

Connect the on-site 3-wire cable (L, N, PE) for the power supply network to the main switch, in accordance with the wiring diagram.

### 7.2.2 Battery connection

The batteries must be connected by means of the cables provided for that purpose. The screws of the hose clamps must be fully tightened.

### 7.2.3 Connection of the malfunction signals/run signals

A signal can be withdrawn via a potential-free contact on the terminal strip for the malfunction/running messages in order to signal a malfunction/operation (see wiring diagram).

Potential-free, contact load max. 250 V ~/1 A

**“GENERAL MALFUNCTION”**

Activation of the signal output if the following malfunctions occur:

- “MAINS MALFUNCTION”
- “PRE-HEATING MALFUNCTION”
- “OIL PRESSURE MALFUNCTION”
- “WATER TEMPERATURE MALFUNCTION”
- “BATTERY 1/2 MALFUNCTION”
- “BATTERY CHARGER 1/2 MALFUNCTION”

**“RISK OF FAILURE”**

Activation of the signal output if the following malfunctions occur:

- “SYSTEM MALFUNCTION”
- “CLOGGING MALFUNCTION”
- “STARTER MALFUNCTION”
- “WATER TANK LEVEL MALFUNCTION”
- “LACK OF MOTOR WATER MALFUNCTION”
- “START-UP TANK LEVEL MALFUNCTION”
- “VENT MALFUNCTION”
- “DIESEL LEVEL MALFUNCTION”
- “ROOM TEMPERATURE MALFUNCTION”
- “PRESSURE SWITCH LINE 1/2 MALFUNCTION”

**“NON-AUTO MODE 1”**

The signal output is activated if the corresponding key switch is in the “0” or “Manual” position. In the non-automatic mode, no automatic start-up of the diesel motor is possible via the intermediary of the float switch or the corresponding pressure switch.

**“NON-AUTO MODE 2”**

The signal output is activated if the corresponding key switch is in the “0” or “Manual” position. In the non-automatic mode, no automatic start-up of the diesel motor is possible via the intermediary of the float switch or the corresponding pressure switch.

**“ON”**

The signal output is activated as soon as the diesel motor has started and when the rotation speed increased by the rotation speed sensor has reached or exceeded the pre-set value for a “motor in operation” (menu 1.2.1.3).

**“START-UP FAILURE”**

The output signal is activated following six consecutive failed start-up attempts.

	Colour of the LED	Buzzer	"GENERAL MALFUNCTION"	"RISK OF FAILURE"	"NON-AUTO MODE 1/2"	"ON"	"START-UP FAILURE"
"LIVE"	green						
"MAINS MALFUNCTION"	yellow		x				
"ON"	green					x	
"SYSTEM MALFUNCTION"	yellow	x		x			
"START-UP FAILURE"	red	x					x
"CLOGGING MALFUNCTION"	red	x		x			
"STARTER MALFUNCTION"	red	x		x			
"PRE-HEATING MALFUNCTION"	red	x	x				
"OIL PRESSURE MALFUNCTION"	red	x	x				
"WATER TANK LEVEL MALFUNCTION"	red	x		x			
"LACK OF MOTOR WATER MALFUNCTION"	red	x		x			
"START-UP TANK LEVEL MALFUNCTION"	red	x		x			
"WATER TEMPERATURE MALFUNCTION"	red	x	x				
"VENT MALFUNCTION"	red			x			
"DIESEL LEVEL MALFUNCTION"	red	x		x			
"ROOM TEMPERATURE MALFUNCTION"	red			x			
"START-UP ATTEMPT"	yellow						
"BATTERY LOAD 1/2"	green						
"BATTERY 1/2 MALFUNCTION"	yellow		x				
"BATTERY CHARGER 1/2 MALFUNCTION"	yellow	x	x				
"AUTO MODE 1/2"	green						
"NON-AUTO MODE 1/2"	red				x		
"START-UP VIA PRESSURE SWITCH 1/2"	green/yellow						
"PRESSURE SWITCH LINE 1/2 MALFUNCTION"	red	x		x			

Table 4: Malfunction signals and run signals



**Warning! Danger of electric shock!**

There is a potentially fatal voltage on these terminals, even when the main switch is turned off.

## 8 Commissioning



**WARNING! Risk of fatal injury!**  
**Commissioning by qualified personnel only!**  
**Improper commissioning poses a risk of fatal injury.**  
**Have commissioning performed by qualified personnel only.**



**DANGER! Risk of fatal injury!**  
**When working on an open switchgear, there is a risk of electrocution in the event of contact with the conductor components.**  
**This work must only be carried out by qualified personnel!**

We recommend that you have the switchgear commissioned by Wilo customer service.  
 Before switching on for the first time, the on-site wiring must be checked, in particular the earthing.



**Tighten all connection terminals prior to commissioning!**

### 8.1 Factory setting

The control is pre-set at the factory.  
 The factory setting can be restored by Wilo customer service.

### 8.2 Rotation speed correction control

The motor rotation speed is fixed at the factory. To check it, the motor is to be started up by a manual function. Once the motor is running, increase the rotation speed by means of a portable tachometer and compare it to the rotation speed displayed on the screen. If the two rotation speeds match, no correction is required.

In case of significant difference, a further correction must be carried out. To do this, proceed as follows. Set the motor at a constant and known rotation speed. Enter this value in the menu 1.2.1.1 and confirm. Move on to the following menu item. In the menu 1.2.1.2, modify the setting by selecting "Start", then confirm. Once the correction is performed, the message "Finished" is displayed on the screen. The rotation speed correction was successful and has been recorded. The motor can be switched off with the "OFF" button if at least one of the key switches is in the "0" position.

### 8.3 Rotation speed correction control

Commissioning at the place of installation requires the automatic device test of the diesel motor start-up. To do this, the fuel supply must be interrupted. In the menu 5.9.1.0, set "Start", then confirm. Then push the button "CLEAR FAULT" (Fig. 2, pos. 20) in the following 10 seconds. 6 automatic start-up attempts thus take place. After 6 start-up attempts, the yellow LED (Fig. 2, pos. 22) signifies a failed start-up. The fuel supply must be restored and the motor must start up as soon as the button is pushed (Fig. 2, pos. 23).

## 9 Maintenance

Have maintenance and repair work carried out by qualified skilled personnel only!



**DANGER! Risk of fatal injury!**

There is a risk of fatal injury from electric shock when working on electrical equipment.

- The switchgear should be electrically isolated and secured against unauthorised switch-on during any maintenance or repair work.
- Any damage to the connection cable should only ever be eradicated by a qualified electrician.
- The switchgear must remain clean.
- Visual inspection of the electrical components of the system in the switchgear.

## 10 Malfunctions, causes and remedies



**DANGER! Risk of fatal injury!**

There is a risk of fatal injury from electric shock when working on electrical equipment.

Have malfunctions remedied by qualified skilled personnel only! Observe the safety instructions under Fehler! Verweisquelle konnte nicht gefunden werden.

Before performing any work to remedy malfunctions, disconnect the unit from the power supply, and make sure it cannot be switched back on by unauthorised persons.

### 10.1 Malfunction indication

When a malfunction is observed, the corresponding LED malfunction indicator turns on, the contact of the corresponding malfunction signal is activated and the malfunction is displayed on the LCD (malfunction code number). An additional buzzer sounds for certain malfunctions. This alarm can be switched off with the button "BUZZER OFF" (Fig. 2, pos. 18) (level of access 1 required).

It is possible to clear the malfunction by pushing the button "CLEAR FAULT" (Fig. 2, pos. 20) (level of access 2 required) or by following the steps described in the menu 6.1.0.0 (level of access 3 required):

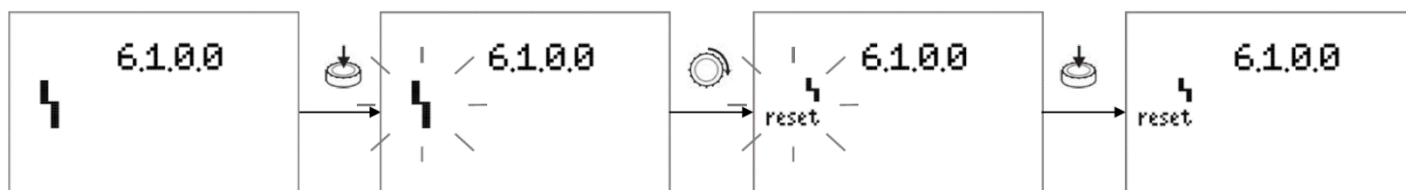



## 10.2 Malfunction history

A history which works according to the FIFO (First In First Out) principle has been created for the switchgear. The memory is configured for 16 malfunctions. The malfunction memory can be called up using menus 6.1.0.1 – 6.1.1.6 (level of access 1 required).

Code	Fault description	Causes	Remedies
E04.1	No connection voltage charger 1	Main switch off	Switch on the main switch
		Blown fuse	Check the fuse and replace it if necessary
E04.2	No connection voltage charger 2	Main switch off	Switch on the main switch
		Blown fuse	Check the fuse and replace it if necessary
E04.3	No connection voltage battery 1	Connection with the battery A interrupted	Check connection
		Blown fuse	Check the fuse and replace it if necessary
E04.4	No connection voltage battery 2	Connection with the battery B interrupted	Check connection
		Blown fuse	Check the fuse and replace it if necessary
E04.5	Undervoltage battery 1	Voltage dropped below the value set in the menu 5.4.1.0	Check battery A and replace it if necessary
			Check charger
			Check the settings in the menu 5.4.1.0 and correct as required
E04.6	Undervoltage battery 2	Voltage dropped below the value set in the menu 5.4.1.0	Check battery B and replace it if necessary
			Check charger
			Check the settings in the menu 5.4.1.0 and correct as required
E40.1	Malfunction of the connection to pressure switch 1	Cable rupture or short-circuit	Check connection
			Request customer service
E40.2	Malfunction of the connection to pressure switch 2	Cable rupture or short-circuit	Check connection
			Request customer service
E54.0	No bus communication with the HMI printed circuit board	Connection with the HMI printed circuit board interrupted	Check connection
			Request customer service
E54.1	No bus communication with the charger of battery 1	Connection with charger 1 interrupted	Check connection
			Request customer service
E54.2	No bus communication with the charger of battery 2	Connection with charger 2 interrupted	Check connection
			Request customer service
E54.3	Incorrect transfer of data from the charger of battery 1	Malfunction on the data line	Request customer service

E54.4	Incorrect transfer of data from the charger of battery 2	Malfunction on the data line	Request customer service
E54.5	No bus communication with the printed circuit board of slave control	Connection with the printed circuit board of slave control interrupted	Check connection
		Software integrity error	Request customer service
E62.0	Low water level	Level below minimum filling level in the storage tank	Filling the storage tank
		Leakage	Check the impermeability of the storage tank and of the core
E64.0	Room temperature under 10 °C	Room not heated	Heat the room
E100.1	Battery 1 malfunction	Battery 1 defective	Check battery 1 and replace it if necessary
			Request customer service
E100.2	Battery 2 malfunction	Battery 2 defective	Check battery 2 and replace it if necessary
			Request customer service
E105.1	Short-circuit battery 1	Battery 1 defective	Check battery 1 and replace it if necessary
			Request customer service
E105.2	Short-circuit battery 2	Battery 2 defective	Check battery 2 and replace it if necessary
E106.1	Cable rupture battery 1	Connection with battery 1 interrupted	Check the connection of battery 1
			Request customer service
E106.2	Cable rupture battery 2	Connection with battery 2 interrupted	Check the connection of battery 2
			Request customer service
E130.0	Insufficient fuel	Fuel level lower than the minimum	Add fuel
E131.0	Heating malfunction	The heating thermostat is triggered	Check heating
E132.0	Low oil pressure	The oil pressure switch is triggered	Check the oil level and fill it if required
			Request customer service
E133.0	Excessive motor temperature	The motor thermostat is triggered	Check the level of the cooling water
			Request customer service
E134.0	Pinion of the non-engaged starter	No response from starter pinion	Check the starter
			Check the fuse
			Request customer service
E135.0	Pinion circuit interrupted	No response from starter pinion	Check the fuse
			Request customer service
E136.0	Start-up failure	6 failed start-up attempts	Request customer service
E137.0	Belt rupture	No alternator voltage	Check the V-belt and replace it in necessary

			Request customer service
E138.0	Insufficient cooling water	Leakage in the cooling water system	Add the cooling water
			Check the impermeability of the cooling water system
E139.0	Clogged filter of the cooling water system	Contaminated cooling water	Eliminate clogging
			Clean the filter
			Request customer service
E150.0	Aeration valve malfunction	The aeration valves have not opened in the 10 seconds following the diesel motor start-up	Check the operation of the aeration valves
		Malfunction of the signal allowing outlet opening of the aeration valves	Check the signal allowing outlet opening of the aeration valves

**If you cannot manage to eliminate a malfunction, please contact Wilo customer service or its nearest representative.**

## 11 Spare parts

Spare parts may be ordered via a local specialist retailer and/or Wilo customer service. To avoid queries and incorrect orders, all data on the rating plate should be submitted with each order.

**Subject to change without prior notice**

## 12 Annexes

### Calculation of battery capacity

#### Standby consumption without 230 V AC power supply

Wiring diagram designation	Component designation	Measurement	Consumption (under 12 V)	Consumption (under 24 V)
7K2	BC6-22-00, 24 V DC		3.50 W	3.50 W
8G1	Signal converter SC-Fire	15 mA under 12.6 V DC	0.19 W	0.19 W
11G1	Signal converter SC-Fire	15 mA under 12.6 V DC	0.19 W	0.19 W
2U1	CPU SC-Fire ED	390 mA under 24 V DC	9.36 W	9.36 W
2U2	CPU SC-Fire ED	390 mA under 24 V DC	9.36 W	9.36 W
	2xUM, 12 V DC, 240 V AC, 6 A		0.40 W	0.40 W
10K1	2xUM, 24 V DC, 240 V AC, 6 A		0.40 W	0.40 W
	2xUM, 12 V DC, 240 V AC, 6 A		0.40 W	0.40 W
10K2	2xUM, 24 V DC, 240 V AC, 6 A		0.40 W	0.40 W
	2xUM, 12 V DC, 240 V AC, 6 A		0.40 W	0.40 W
10K3	2xUM, 24 V DC, 240 V AC, 6 A		0.40 W	0.40 W
	2xUM, 12 V DC, 240 V AC, 6 A		0.40 W	0.40 W
10K4	2xUM, 24 V DC, 240 V AC, 6 A		0.40 W	0.40 W
	2xUM, 12 V DC, 240 V AC, 6 A		0.40 W	0.40 W
10K5	2xUM, 24 V DC, 240 V AC, 6 A		0.40 W	0.40 W
	2xUM, 12 V DC, 240 V AC, 6 A		0.40 W	0.40 W
10K6	2xUM, 24 V DC, 240 V AC, 6 A		0.40 W	0.40 W
	Buzzer 12 V DC	0.019 A under 12 V DC	0.23 W	0.19 W
10H1	Buzzer 24 V DC	0.008 A under 24 V DC		
10K7	BC6-30-10, 24 VDC		3.50 W	3.50 W
	LCD panel meter, EX2071, 0 – 199.9 V		0.04 W	0.08 W
14P1	LCD panel meter, EX2070, 0 – 19.99 V		0.04 W	0.08 W
14P2	LCD panel meter, EX2070, 0 – 19.99 V		0.04 W	0.08 W
15P1	06000002, 12 V, Ø 56 mm		2.00 W	2.00 W
	06000003, 40 – 120 °C, 12 V, Ø 56 mm		2.00 W	2.00 W
15P2	06000006, 0 – 8 bar, 12 V, Ø 56 mm		2.00 W	2.00 W
15P3	06000006, 0 – 8 bar, 12 V, Ø 56 mm		2.00 W	2.00 W
15P4	12 V, Ø 90.5 mm		2.00 W	2.00 W
			<b>Total: 37 W</b>	<b>37 W</b>

P = 28 W  
(29 W)  
U = 12 V  
(24 V DC)  
h = 72 h

Consumption without power supply 230 V

Battery voltage

Time required for independent operation

$$I = \frac{37W}{12V}$$

$$Q = \frac{37W}{12V} * 72h = 222Ah$$

$$I = \frac{37W}{24V}$$

$$Q = \frac{37W}{24V} * 72h = 111Ah$$

222 Ah required  
on 2 batteries  
**2 x 111 Ah**  
under 12 V

111 Ah required  
on 2 batteries  
**2 x 56 Ah**  
under 24 V

## Details of the diesel cabinet terminal blocks

Terminal block no.	Terminal no.	Designation	Signal type
X0	1	Connection voltage cabinet	Power supply performance (230 V)
	2		
X1	1	Diesel oil pre-heating	Power supply performance (230 V, max 10 A)
	2		
X4	1	Pressure switch 1	DI
	2		
	3	Pressure switch 2	DI
	4		
	5	Fuel malfunction	DI (Float switch, contact closed when the tank level is low, i.e. malfunction)
	6		
	7	Pre-heating diesel malfunction	DI (Thermostat, contact closed when operation OK)
	8		
	9	Motor oil malfunction	DI (Pressure switch, ground contact when low pressure malfunction)
	10	Motor temperature malfunction	DI (Thermostat, ground contact when the temperature is too high)
	11	Motor oil pressure	AI (Pressure sensor with resistor, 270...30 Ω ± 0...8 bars)
	12		
	13	Cooling liquid temperature	AI (Temperature sensor with resistor, 1805...110 Ω ± 10...90 °C)
	14		
	15	Motor oil temperature	AI (Temperature sensor with resistor, 1805...43 Ω ± 10...130 °C)
	16		
	17	External water temperature	AI (Temperature sensor with resistor, 1805...110 Ω ± 10...90 °C)
	18		
	19	Motor speed (used by the controller but not for the tachometer)	AI (Frequency sensor, 0...10 kHz)
	20		
	21	Cooling water malfunction	DI (Float switch, closed in case of low level)
	22		
	23	Motor cooling line filter malfunction	DI (Differential pressure sensor, closed if the filter is not clogged)
	24		
	25	Aeration vent malfunction	DI (position contact, closed if the vents are open)
	26		
	27	Technical room temperature malfunction	DI (Thermostat, open when the temperature is too low)
	28		

	29 30	Pump pressure switch in demand	DI (Pressure switch, contact closed when the pump is running)
	31 32	Start-up tank malfunction	DI (Float switch, contact closed at low level)
	33 34	Water tank malfunction	DI (Float switch, contact closed at low level)
	35	Diesel motor pinion malfunction	DI (Starter signal, 12/24 V DC when the pinion is engaged, 0 V when the pinion is not engaged and 8 V when the wire is cut or HS fuse)
	36	Belt malfunction	DI (Motor signal, signal 12/24 V DC when the belt is OK)
	37 38	Valve status of bypass filter line of cooling	DI (signal when the valve is open)
	39 40	Fuel level	AI (Resistor level sensor)
	41 42	Motor speed (only for the countdown on the front of the cabinet)	AI (Alternator signal of the diesel motor)
X7	1 2 3 4	General malfunction (2 contacts no/nc)	DO (NO) DO (NC)
	5 6 7 8	Pump running (2 contacts no/nc)	DO (NO) DO (NC)
	9 10 11 12	Start-up failed (2 contacts no/nc)	DO (NO) DO (NC)
	13 14 15 16	Risk of failure (2 contacts no/nc)	DO (NO) DO (NC)
	17 18 19 20	Automatic mode deactivated on battery 1 (2 contacts no/nc)	DO (NO) DO (NC)
	21 22 23	Automatic mode deactivated on battery 2 (2 contacts no/nc)	DO (NO) DO (NC)

	24			
	25		Motor active	DO (12/24 V DC signal during diesel motor operation)
	26	}	Motor fan active	DO (contact NO, closed when the diesel motor is running)
	27			
	28	}	Bypass valve of the cooling filter	DO (contact NO in terminals 28-30, contact NC in terminals 29-30)
	29			
	30			
X8	1	}	RS485 Modbus or Bacnet	Connection of communication bus
	2			
X10	1		Battery 1	Input performance (positive pole of battery 1, in 12 or 24 V DC)
	2		Battery 2	Input performance (positive pole of battery 2, in 12 or 24 V DC)
	3		Starter performance	Performance output (starting current for the diesel starter, in 12 or 24 V DC)
	4	}	GND	Ground connection of the batteries and diesel motor
	5			
	6		Operation relay starter (auxiliary)	Auxiliary voltage output (operation of the relay coil, in 12 or 24 V DC)
	7	}	Electric switch off of the diesel motor	Control voltage output (for the electric shut-off device, in 12 or 24 V DC)
	8			
	9		Load current (alternator)	Performance input (load current between the generator and switchgear during pump operation)

## External connection of the diesel cabinet

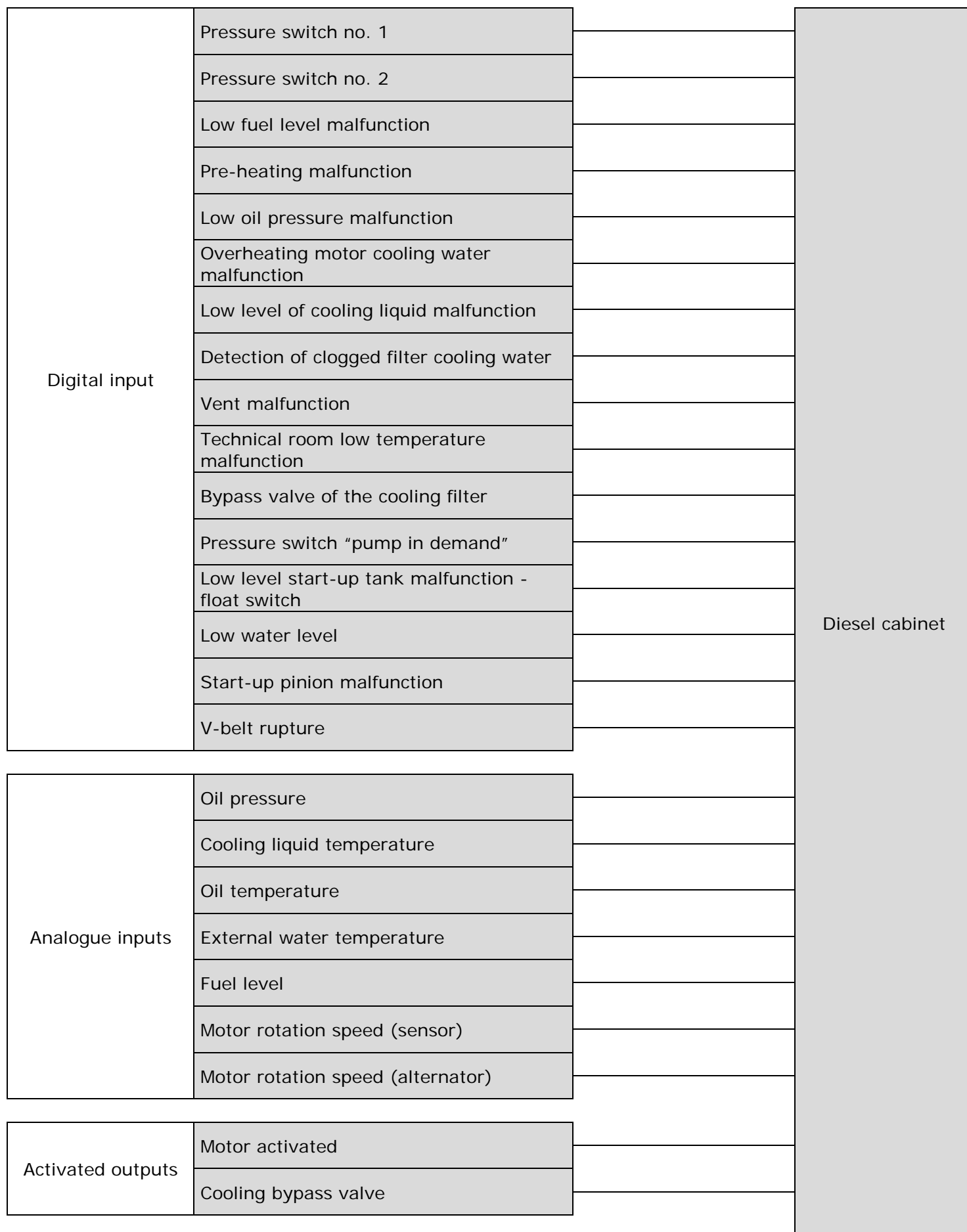



Potential-free contact (NO)	Fan motor active	
Communication bus	RS485 Modbus or Bacnet	
Potential-free contact (NO/NC)	General malfunction	
	Pump running	
	Start-up failed	
	Risk of error	
	Automatic stop 1	
	Automatic stop 2	
Power supply input performance	Connection voltage 230 V AC	
	Battery 1	
	Battery 2	
	Load current of the diesel motor	
Output performance	Oil pre-heating	
	Starter - Starting current	
	Starter - Auxiliary voltage	
	Electric switch off of the diesel	
Mass	GND	

# Details of the terminal blocks of the PCB master/diesel slave SC-Commande Diesel

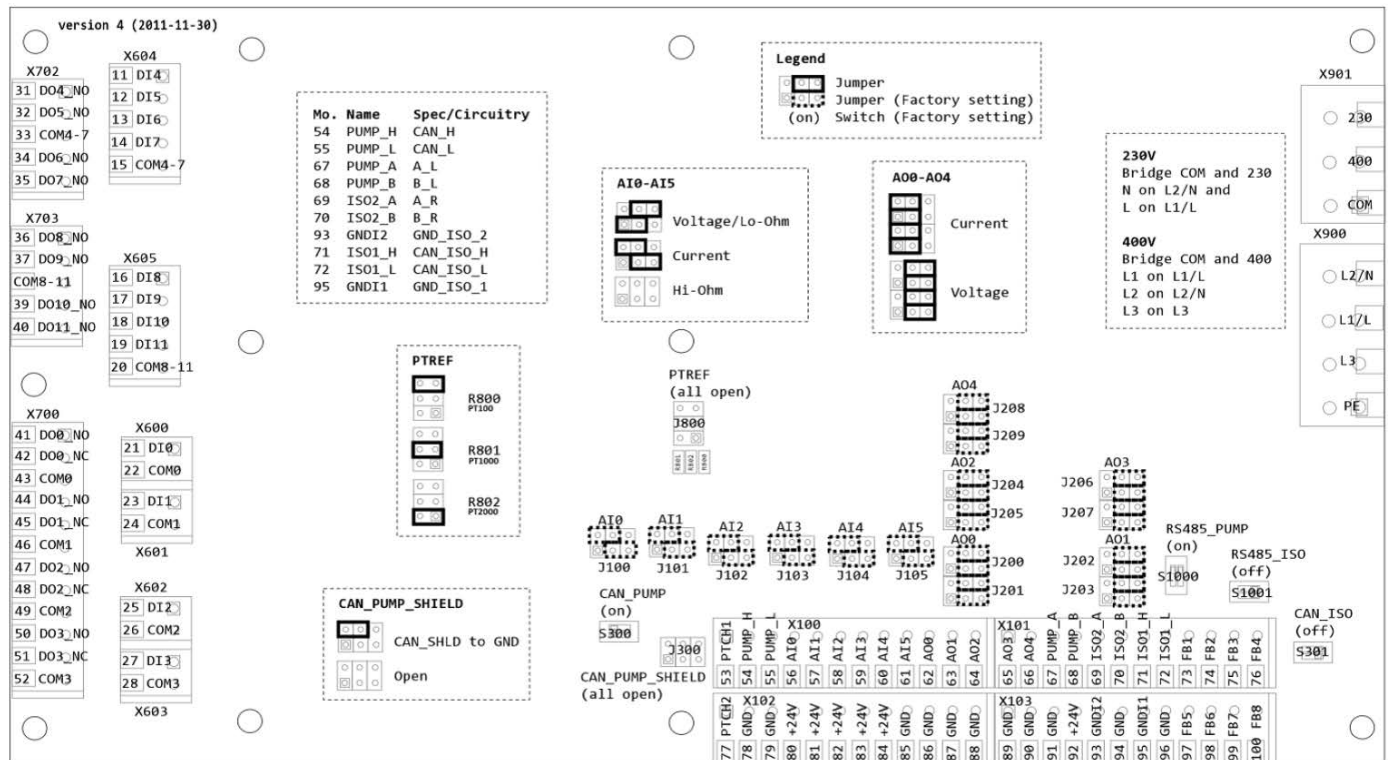
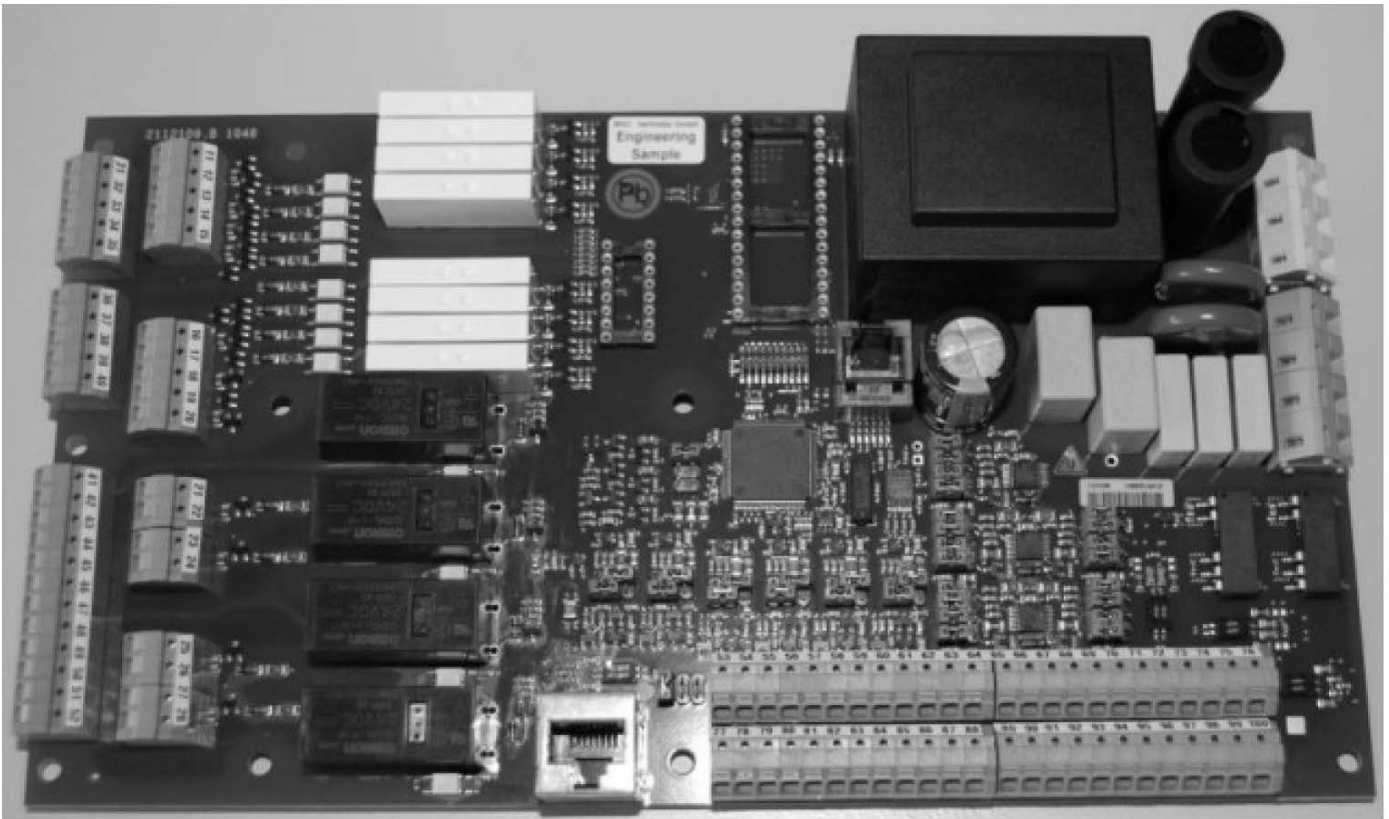

PCB - 2U1 (Master)			PCB - 2U2 (Slave)		
<b>X901</b>		<b>Used for:</b>	<b>X901</b>		<b>Used for:</b>
C		Shunt to power at 230 V AC	C		Shunt to power at 230 V AC
230 V			230 V		
400 V			400 V		
<b>X900</b>		<b>Used for:</b>	<b>X900</b>		<b>Used for:</b>
PE		Earth connection	PE		Earth connection
L3			L3		
L1(L)		Power supply to the PCB (2U1): Live wire 230 V	L1(L)		Power supply to the PCB (2U2): Live wire 230 V
L2(N)		Power supply to the PCB (2U1): Neutral 230 V	L2(N)		Power supply to the PCB (2U2): Neutral 230 V
<b>X100</b>		<b>Used for:</b>	<b>X100</b>		<b>Used for:</b>
53	Temp In 1		53	Temp In 1	
54	CAN_H		54	CAN_H	
55	CAN_L		55	CAN_L	
56	Analogue In 0		56	Analogue In 0	Key switch to access level 2 (TOR)
57	Analogue In 1		57	Analogue In 1	Monitoring of the general inter/switch amplifier 230 V (TOR)
58	Analogue In 2	Oil temperature (variable resistance)	58	Analogue In 2	Monitoring of the 230 V power supply of battery 1 charger (TOR)
59	Analogue In 3	Speed sensor of the diesel motor (variable frequency)	59	Analogue In 3	Monitoring of the 230 V power supply of battery 2 charger (TOR)
60	Analogue In 4	External temperature of the water (variable resistance)	60	Analogue In 4	
61	Analogue In 5		61	Analogue In 5	
62	Analogue Out 0		62	Analogue Out 0	
63	Analogue Out 1		63	Analogue Out 1	Load current of battery 1 for the LCD display (signal originating from charger via a COM bus)
64	Analogue Out 2		64	Analogue Out 2	Load current of battery 2 for the LCD display (signal originating from charger via a COM bus)
<b>X101</b>		<b>Used for:</b>	<b>X101</b>		<b>Used for:</b>
65	Analogue Out 3		65	Analogue Out 3	
66	Analogue Out 4		66	Analogue Out 4	
67	RS485 A_L		67	RS485 A_L	Internal bus: Battery 1 charger
68	RS485_B_L		68	RS485_B_L	Internal bus: Battery 1 charger
69	RS485_A_R	RS485: Output Modbus or Bacnet	69	RS485_A_R	Internal bus: Battery 2 charger
70	RS485_B_R	RS485: Output Modbus or Bacnet	70	RS485_B_R	Internal bus: Battery 2 charger

71	CAN_ISO_H	CAN: towards printed circuit board slave (2U2)	71	CAN_ISO_H	CAN: from the master printed circuit board (2U1) and towards the printed circuit board LED/button (12P1)
72	CAN_ISO_L	CAN: towards printed circuit board slave (2U2)	72	CAN_ISO_L	CAN: from the master printed circuit board (2U1) and towards the printed circuit board LED/button (12P1)
73	Field Bus1		73	Field Bus1	
74	Field Bus2		74	Field Bus2	
75	Field Bus3		75	Field Bus3	
76	Field Bus4		76	Field Bus4	
<b>X102</b>		<b>Used for:</b>	<b>X102</b>		<b>Used for:</b>
77	Temp In 2		77	Temp In 2	
78	GND	Earthed with PE bar	78	GND	Earthed with PE bar
79	GND	Analogue input (GND)	79	GND	
80	VCC24V		80	VCC24V	
81	VCC24V	Power supply 24V DC from the PCB (2U1)	81	VCC24V	Power supply 24 V DC from the PCB (2U2)
82	VCC24V		82	VCC24V	
83	VCC24V		83	VCC24V	
84	VCC24V		84	VCC24V	
85	GND		85	GND	
86	GND		86	GND	
87	GND		87	GND	
88	GND		88	GND	
<b>X103</b>		<b>Used for:</b>	<b>X103</b>		<b>Used for:</b>
89	GND	GND - Speed sensor of the diesel motor	89	GND	
90	GND	GND - Power supply 24 V DC to the PCB (2U1)	90	GND	GND - Power supply 24 V DC to the PCB (2U2)
91	GND		91	GND	GND - Power supply from the CAN bus from the printed circuit board LED
92	VCC24V		92	VCC24V	24 V DC - Power supply from the CAN bus from the printed circuit board LED
93	GND		93	GND	
94	GND		94	GND	
95	GND		95	GND	
96	GND	GND - Shielding of the CAN cable of the printed circuit board LED	96	GND	GND - Shielding of the CAN cable of the printed circuit board LED
97	Field Bus5		97	Field Bus5	
98	Field Bus6		98	Field Bus6	
99	Field Bus7		99	Field Bus7	
100	Field Bus8		100	Field Bus8	
<b>X600</b>		<b>Used for:</b>	<b>X600</b>		<b>Used for:</b>
21	Digital In 0	Pressure switch no. 1	21	Digital In 0	Start-up tank float switch - Malfunction low level

22	COM 0	GND		22	COM 0	GND
<b>X601</b>			<b>Used for:</b>	<b>X601</b>		
23	Digital In 1	Pressure switch no. 2		23	Digital In 1	Main water tank - Malfunction low level
24	COM 1	GND		24	COM 1	GND
<b>X602</b>			<b>Used for:</b>	<b>X602</b>		
25	Digital In 2	Malfunction of pressure switch no. 1		25	Digital In 2	Diesel motor pinion engaged: GND - Pinion not engaged 12 V - Pinion engaged 8 V - Wire cut or HS fuse
26	COM 2	GND		26	COM 2	GND
<b>X603</b>			<b>Used for:</b>	<b>X603</b>		
27	Digital In 3	Malfunction of pressure switch no. 2		27	Digital In 3	Malfunction - Rupture of the diesel belt (option, can be activated or not in the menu)
28	COM 3	GND		28	COM 3	GND
<b>X604</b>			<b>Used for:</b>	<b>X604</b>		
11	Digital In 4	Fuel - Malfunction low level		11	Digital In 4	Cooling liquid - Malfunction low level
12	Digital In 5	Pre-heating - Malfunction thermostat		12	Digital In 5	Cooling liquid - Malfunction clogged filter Pressure sensor differential
13	Digital In 6	Oil motor - Malfunction weak pressure		13	Digital In 6	Aeration vents - Malfunction of outlet opening
14	Digital In 7	Cooling motor - Malfunction excessive temp		14	Digital In 7	Technical room temperature - Malfunction low temp
15	COM 4-7	24 V DC or 12 V DC (depends on the type of battery)		15	COM 4-7	GND
<b>X605</b>			<b>Used for:</b>	<b>X605</b>		
16	Digital In 8	Key switch no. 1 in Manual position		16	Digital In 8	Battery 1 voltage (generates the error code 4.3)
17	Digital In 9	Key switch no. 1 in Auto position		17	Digital In 9	Battery 2 voltage (generates the error code 4.4)
18	Digital In 10	Key switch no. 2 in Manual position		18	Digital In 10	Bypass valve of the cooling circuit filter - open position
19	Digital In 11	Key switch no. 2 in Auto position		19	Digital In 11	Pressure switch of the "pump in demand" - monitors to ensure the pump runs
20	COM 8-11	GND		20	COM 8-11	GND
<b>X700</b>			<b>Used for:</b>	<b>X700</b>		
41	Relay 0 NO	Motor running		41	Relay 0 NO	Automatic stop on battery 1 (contact available)
42	Relay 0 NC			42	Relay 0 NC	
43	Relay 0 COM	24 V DC		43	Relay 0 COM	24 V DC
44	Relay 1 NO	Motor stopped		44	Relay 1 NO	Automatic stop on battery 2

					(contact available)
45	Relay 1 NC		45	Relay 1 NC	
46	Relay 1 COM	24 V DC or 12 V DC (depends on the type of battery)	46	Relay 1 COM	24 V DC
47	Relay 2 NO	Bypass valve of the cooling circuit filter	47	Relay 2 NO	Alarm siren sound
48	Relay 2 NC	Bypass valve of the cooling circuit filter	48	Relay 2 NC	
49	Relay 2 COM	24 V DC	49	Relay 2 COM	24 V DC
50	Relay 3 NO	Battery charger switch	50	Relay 3 NO	Pre-heating oil motor - On/off
51	Relay 3 NC		51	Relay 3 NC	
52	Relay 3 COM	24 V DC	52	Relay 3 COM	24 V DC
<b>X702</b>		<b>Used for:</b>	<b>X702</b>		<b>Used for:</b>
31	Relay 4 NO	Start-up battery 1 (Automatic)	31	Relay 4 NO	General malfunction (contact available)
32	Relay 5 NO	Start-up battery 1 (Manual)	32	Relay 5 NO	Pump running (contact available)
33	Relay 4-7 COM	12 V DC	33	Relay 4-7 COM	24 V DC
34	Relay 6 NO		34	Relay 6 NO	Motor start-up failure (contact available)
35	Relay 7 NO		35	Relay 7 NO	Risk of failure (contact available)
<b>X703</b>		<b>Used for:</b>	<b>X703</b>		<b>Used for:</b>
36	Relay 8 NO	Start-up battery 2 (Automatic)	36	Relay 8 NO	
37	Relay 9 NO	Start-up battery 2 (Manual)	37	Relay 9 NO	
38	Relay 8-11 COM	12 V DC	38	Relay 8-11 COM	
39	Relay 10 NO		39	Relay 10 NO	
40	Relay 11 NO		40	Relay 11 NO	

# wilo

Pioneering for You

WILO SE  
Nortkirchenstraße 100  
D-44263 Dortmund  
Germany  
T +49(0)231 4102-0  
F +49(0)231 4102-7363  
wilo@wilo.com  
www.wilo.com