

## Wilo-DrainLift SANI-L



en Installation and operating instructions



DrainLift SANI-L  
<https://qr.wilo.com/482>

## Table of Contents

|   |           |   |           |
|---|-----------|---|-----------|
| <b>1 General</b> .....                                  | <b>4</b>  | <b>9 Shutdown/dismantling</b> .....   | <b>23</b> |
| 1.1 About these instructions .....                      | 4         | 9.1 Staff qualifications .....  | 23        |
| 1.2 Copyright .....                                     | 4         | 9.2 Operator responsibilities .....   | 23        |
| 1.3 Subject to change.....                              | 4         | 9.3 Shutdown.....   | 23        |
| 1.4 Exclusion from warranty and liability.....          | 4         | 9.4 Removal .....   | 23        |
| <b>2 Safety</b> .....                                   | <b>4</b>  | 9.5 Clean and disinfection .....  | 24        |
| 2.1 Safety signs, instructions, and text markups.....   | 4         | <b>10 Maintenance and repair</b> .....  | <b>24</b> |
| 2.2 Staff qualifications .....                          | 5         | 10.1 General overhaul.....  | 25        |
| 2.3 Protective equipment for staff .....                | 5         | <b>11 Spare parts</b> .....   | <b>25</b> |
| 2.4 Electrical work .....                               | 6         | <b>12 Disposal</b> .....  | <b>25</b> |
| 2.5 Monitoring devices .....                            | 6         | 12.1 Protective clothing.....   | 25        |
| 2.6 Pumping of fluids that are hazardous to health..... | 6         | 12.2 Operating fluids .....   | 25        |
| 2.7 Explosive atmosphere in the collection tank.....    | 6         | 12.3 Information on the collection of used electrical and elec-<br>tronic products..... | 25        |
| 2.8 Transport.....                                      | 6         |   |           |
| 2.9 Installing/dismantling.....                         | 6         |   |           |
| 2.10 During operation .....                             | 7         |   |           |
| 2.11 Cleaning and disinfection .....                    | 7         |   |           |
| 2.12 Maintenance tasks.....                             | 7         |   |           |
| 2.13 Operator responsibilities .....                    | 7         |   |           |
| <b>3 Application/use</b> .....                          | <b>7</b>  |   |           |
| 3.1 Intended use .....                                  | 7         |   |           |
| 3.2 Fluids.....   | 7         |   |           |
| 3.3 Improper use.....                                   | 8         |   |           |
| <b>4 Product description</b> .....                      | <b>8</b>  |   |           |
| 4.1 Design.....   | 8         |   |           |
| 4.2 Materials.....                                      | 9         |   |           |
| 4.3 Monitoring devices .....                            | 9         |   |           |
| 4.4 Operating principle .....                           | 9         |   |           |
| 4.5 Operation with frequency converter .....            | 9         |   |           |
| 4.6 Type key.....                                       | 9         |   |           |
| 4.7 Technical data .....                                | 9         |   |           |
| 4.8 Manufacturer date .....                             | 10        |   |           |
| 4.9 Scope of delivery.....                              | 10        |   |           |
| 4.10 Accessories .....                                  | 11        |   |           |
| <b>5 Transportation and storage</b> .....               | <b>11</b> |   |           |
| 5.1 Delivery.....                                       | 11        |   |           |
| 5.2 Transport.....                                      | 11        |   |           |
| 5.3 Storage .....                                       | 11        |   |           |
| <b>6 Installation and electrical connection</b> .....   | <b>12</b> |   |           |
| 6.1 Staff qualifications .....                          | 12        |   |           |
| 6.2 Installation types .....                            | 12        |   |           |
| 6.3 Operator responsibilities .....                     | 12        |   |           |
| 6.4 Installation .....                                  | 12        |   |           |
| 6.5 Electrical connection.....                          | 18        |   |           |
| <b>7 Commissioning</b> .....                            | <b>20</b> |   |           |
| 7.1 Staff qualifications .....                          | 20        |   |           |
| 7.2 Operator responsibilities .....                     | 20        |   |           |
| 7.3 Operation .....                                     | 20        |   |           |
| 7.4 Test run .....                                      | 20        |   |           |
| 7.5 Follow-up time.....                                 | 21        |   |           |
| 7.6 Setting the venting screw .....                     | 21        |   |           |
| <b>8 Operation</b> .....                                | <b>21</b> |   |           |
| 8.1 Application limits .....                            | 22        |   |           |
| 8.2 During operation.....                               | 22        |   |           |
| 8.3 Emergency operation.....                            | 22        |   |           |

## 1 General

- 1.1 About these instructions** These instructions are a part of the product. Obey the instructions for correct handling and use:
- Read the instructions carefully before all works.
  - Keep the instructions easily get access to.
  - Follow the product specifications.
  - Follow the markings on the product.
- 1.2 Copyright** WILO SE © 2025  
The reproduction, distribution, and use of this document and the communication of its contents to others without express consent is prohibited. Infringement results in the obligation to pay for damages. All rights reserved.
- 1.3 Subject to change** Wilo reserves the right to change the listed data without prior notice and is not liable for technical inaccuracies and/or omissions. The illustrations vary from the original and are intended as a sample representation of the product.
- 1.4 Exclusion from warranty and liability** Wilo accepts no warranty or liability in these cases:
- Wrong configuration because the operator or the customer did not give enough or correct instructions
  - Non-compliance with these instructions
  - Incorrect use of the product
  - Incorrect storage or transport
  - Incorrect installation or dismantling
  - Not sufficient maintenance
  - Non-approved repairs
  - Not applicable installation location
  - Chemical, electrical or electrochemical causes
  - Wear of product components

## 2 Safety

### 2.1 Safety signs, instructions, and text markups

This section contains safety information for each phase of the product's lifecycle. Disregarding this information leads to:

- Danger to persons
- Danger to the environment
- Damage to property
- Loss of claims for damages

The safety instructions are structured as below:

- Danger to persons: signal word, safety symbol, text, and shaded grey.
- Property damage: signal word and text.

#### Signal words

- **DANGER!**  
Disregarding these instructions leads to death or serious injury.
- **WARNING!**  
Disregarding these instructions leads to (serious) injury.
- **CAUTION!**  
Disregarding these instructions leads to property damage or even a total loss.
- **NOTICE!**  
Useful information for handling the product.

#### Text markups

- ✓ Precondition
- 1. Work step/list
  - ⇒ Notice/instructions
  - ▶ Result

#### Cross-references

The name of the section or table is in quotation marks “ ”. The page number follows in square brackets [ ].

#### Overview of safety symbols



Danger of death because of electric shock



## 2.2 Staff qualifications

- The staff knows the local accident prevention regulations.
- The staff reads and understands these instructions.
- Electrical work: Only a qualified electrician must do the work.  
Necessary knowledge: identification and prevention of electrical hazards
- Installation and dismantling: Only a specialist in sanitary facilities must do the work.  
Necessary knowledge: fastening of the buoyancy safeguard, connection of plastic pipes
- Maintenance work: Only a specialist in sanitary installation must do the work.  
Necessary knowledge: EN 12056 standard, awareness of the danger of sewage

This product is not for use by:

- Persons (including children) below the age of 16.
- Persons below the age of 21 without supervision from an expert.
- Persons with reduced physical, sensory, or mental abilities.

## 2.3 Protective equipment for staff

This protective equipment is the necessary basic equipment. Obey the factory regulations.

### Protective equipment: transport, installation, removal, and maintenance

- Safety shoes: Protection class S1 (uvex 1 sport S1)
- Safety gloves: 4X42C (uvex C500 wet)
- Safety helmet (EN 397): conforms to the standard and protects against lateral deformation  
(If lifting accessories are used)

### Protective equipment: cleaning work

- Safety gloves: 4X42C + Type A (uvex protector chemical NK2725B)
- Safety glasses: uvex skyguard NT

- Marking of frame: W 166 34 F CE
- Marking of eyeglass–lens: 0–0.0\* W1 FKN CE
- \* The safety class for filters is not necessary for this work.

- Respiratory mask: Half mask 3M series 6000 with filter 6055 A2

#### Article recommendations

The mentioned branded articles are non-binding suggestions. Equivalent products from other brands can also be used. The prerequisite is obeying the standards mentioned.

WILO SE accepts no liability for the articles mentioned regarding their conformity to the applicable standards.

## 2.4 Electrical work

- Do electrical work only by a qualified electrician.
- Make sure that the product is disconnected from the mains connection. Prevent the product from unwanted switching on.
- Obey the local regulations for the mains connection.
- Obey the specifications of the local energy supplier for the mains connection.
- The staff knows the electrical connections.
- The staff knows the shutdown options for the product.
- Follow the technical data on the rating plate and in these instructions.
- Earth the product.
- To prevent switchgears from flooding, install switchgears at a sufficient height.
- Replace damaged cables. Contact customer service for this work.

## 2.5 Monitoring devices

Provide the monitoring devices listed below on-site:

#### Circuit breaker

- The type and switching characteristics of the circuit breakers must be compatible with the rated current of the connected product.
- Obey local regulations.

#### Residual-current device (RCD)

- If persons can touch the device and conductive fluids, install a residual-current device (RCD).
- Obey the regulations of the local energy supplier.

## 2.6 Pumping of fluids that are hazardous to health

There is a risk of bacterial infection when touching the fluid in the lifting unit.

- Wear protective equipment.
- Clean and disinfect the tank after removal.
- Tell all persons about the pumped fluid and the danger.

## 2.7 Explosive atmosphere in the collection tank

Sewage containing faeces can lead to gas collections in the tank. These gas collections can come out into the operating space because of incorrect installation or maintenance work. An explosive atmosphere can occur. This atmosphere can ignite and lead to an explosion. To prevent an explosive atmosphere, follow these points:

- Only use undamaged tanks (no cracks, leaks, porous material). Switch off lifting units with damaged tanks immediately.
- Make sure that all connections for the inlet, discharge pipe, and ventilation are sealed tightly. Obey local regulations for these connections.
- Route the ventilation pipe.
  - For floor-mounted or concealed-wall installation in buildings, route the ventilation pipe over the roof of the building. Obey the local regulations for the correct length of the pipe above the roof.
  - For concealed-floor installation (underground installation) outside of buildings, route the ventilation pipe over the surface. Obey the local regulations for the correct length of the pipe above the surface.
- When opening the tank (e.g. during maintenance work), make sure that the operating space is sufficiently ventilated.

## 2.8 Transport

- Obey local regulations and laws on accident prevention and work safety on-site.
- Move the product by the grip strap at the tank.
- Move and set up the product with two persons.

#### Packaging guidelines

- Make sure that the packaging is shock resistant.
- Make sure that the packaging is moisture resistant.
- Make sure that the packaging permits safety fastening.
- Make sure that the packaging prevents against dirt, dust, and oil.

## 2.9 Installing/dismantling

- Obey local regulations and laws on accident prevention and work safety on-site.
- Make sure that the product is disconnected from the mains connection. Prevent the product from unwanted switching on.
- When dismantling, shut off inlet and discharge pipe.

- Ventilate closed rooms.
  - Do not work alone in closed rooms. Only do this work with a second person.
  - Toxic or asphyxiating gases can collect in closed rooms or buildings. Wear protective equipment (e.g., gas detector). Obey the factory regulations.
  - Clean the product thoroughly.  
**Risk of fire from static load.** Make sure to wear antistatic clothing when cleaning plastic parts. Do not use highly flammable cleaning agents.
- 2.10 During operation**
- Open all shut-off valves in the inlet and discharge pipe.
  - The maximum inflow must be less than the maximum output of the system.
  - Do not open the inspection opening.
  - Make sure that the operating space is sufficiently ventilated.

---

## CAUTION

### Property damage through overpressure in the collection tank!

If there is overpressure in the collection tank, the tank can break. To prevent overpressure in the collection tank, follow these points:

- The maximum inlet height of the lowest inlet is 5 m (16.5 ft).
  - The maximum inflow must be lower than the maximum volume flow at the duty point.
  - The maximum permitted pressure in the discharge line is 6 bar (87 psi).
- 

- 2.11 Cleaning and disinfection**
- Wear protective equipment. Obey the factory regulations.
  - Use a disinfectant. Follow the manufacturer's instructions:
    - Wear the given protective equipment. If you are not sure, contact your supervisor.
    - Give the staff the necessary information about the disinfectant and its correct use.
- 2.12 Maintenance tasks**
- Maintenance work: Do the work only by a specialist for lifting units.  
Necessary knowledge: sanitary installation
  - Make sure that the product is disconnected from the mains connection. Prevent the product from unwanted switching on.
  - Clean the product thoroughly.  
**Risk of fire from static load.** Make sure to wear antistatic clothing when cleaning plastic parts. Do not use highly flammable cleaning agents.
  - When dismantling, shut off inlet and discharge pipe.
  - Only use original parts from the manufacturer. The use of non-original parts releases the manufacturer from all liability.
  - Immediately clean up and remove leaked liquids (fluid, operating fluid). Obey local regulations to dispose of these liquids.
- 2.13 Operator responsibilities**
- Supply these instructions in the language which the staff can read and understand.
  - Make sure that staff are trained to do the set tasks.
  - Supply protective equipment. Make sure that staff wears protective equipment.
  - Make sure that attached safety and warning signs are clearly readable.
  - Tell staff how the system operates.
  - Mark and close the working area.

## 3 Application/use

- 3.1 Intended use**
- As a lifting unit for floor-mounted or concealed-wall installation in buildings, or for concealed-floor installation in pump chambers:
- In cases where sewage cannot be discharged directly into the sewer system through a natural downward slope
  - For backflow resistant drainage in cases where the discharge point is below the back-flow level
- NOTICE! When pumping sewage with oil or grease content, install an oil and grease separator before the lifting unit.**
- 3.2 Fluids**
- For the collection and pumping of these fluids in commercial areas:
- Sewage with faeces
  - Sewage **without** faeces
- The **C** version is for pumping aggressive fluids:
- Condensate from boilers
- CAUTION! Do not pump pure condensate. Only pump condensates mixed with sewage.**

- Lake water and sea water  
Max. NaCl content (salt water): 30 g/l until 20 °C
- Swimming pool water, max. chloride content: 400 mg/l
- Wastewater, slightly acidic with a pH value >3.5
- Demineralised/cleaned water

#### Sewage pumping according to 12050

The lifting unit follows DIN EN 12050-1.

### 3.3 Improper use



#### DANGER

##### Explosion hazard when pumping explosive fluids!

The lifting unit is not designed to pump highly flammable and explosive fluids. There is a danger of death through explosion.

- Do not pump highly flammable and explosive fluids (e.g., gasoline, kerosene, ...).

Do **not** use for these fluids:

- Sewage from discharge points higher than the backflow level which can be discharged directly into the sewer system through a natural downward slope
- Debris, ash, rubbish, glass, sand, plaster, cement, lime, mortar, fibrous materials, textiles, paper towels, wet wipes (e.g. fleece cloths, moist toilet paper wipes), nappies, cardboard, coarse paper, synthetic resins, tar, kitchen waste, grease, oil
- Slaughterhouse waste, disposal of slaughtered animals and animal waste (liquid manure etc.)
- Toxic, aggressive and corrosive fluids, such as heavy metals, biocides, pesticides, acids, bases, salts, swimming pool water
- Cleaning agents, disinfectants, dishwashing or laundry detergents in too much quantities, which have a disproportionately high degree of foam formation
- Drinking water

To use the product correctly, follow these installation and operating instructions.

## 4 Product description

### 4.1 Design



Fig. 1: Overview

Compact, ready for connection, and fully submersible double pump lifting unit for pumping sewage containing faeces.

|   |  |
|---|--|
| 1 | Collection tank                        |
| 2 | Inspection opening of collection tank  |
| 3 | Ventilation connection                 |
| 4 | Discharge port                         |
| 5 | Inspection opening of non-return valve |
| 6 | Grip strap                             |
| 7 | Drain connection                       |
| 8 | Motor                                  |

Gas- and watertight collection tank:

- Sloped floor at an angle
- Inspection opening with transparent cover
- Freely selectable inlets in the shown areas
- Level measurement with a level sensor 4 ... 20 mA

Sewage pump:

- Mounted directly on the collection tank
- Surface-cooled (air) or self-cooling (sheath flow cooling) motor with thermal motor monitoring
- Discharge port with non-return valve including inspection opening attached

Pre-wired switchgears for automatic operation:

#### Wilo-Control MS-L

- Collective fault signal with potential-free contact
- Integrated and mains-independent alarm
- Adjustable follow-up time
- 1.5 m connection cable with attached plug

#### Wilo-Control EC-L



- Operation through display and icon-based, alphanumeric menu
- Collective fault signal with potential-free contact
- Individual fault signal with potential-free contact
- ModBus interface
- Integrated and mains-independent alarm
- Adjustable follow-up time

#### 4.2 Materials

- Motor housing: 1.4404 (AISI 316L)
- Hydraulics: PP-GF30
- Impeller: PP-GF30 or 1.4408 (AISI 316)
- Tank: PE
- Non-return valve: PPS

#### 4.3 Monitoring devices

##### Monitoring of motor winding

The motor has thermal motor monitoring with bimetallic sensor:

- Single-phase AC motor: The motor monitoring is self-switching. The motor switches off if it overheats. The motor automatically switches on again when it has cooled down.
- Three-phase AC motor: The motor monitoring is displayed and reset through the connected switchgear.

##### High water alarm with collective fault signal

When the water comes to the switch-on level, a sound and visual alarm signal starts. The pump automatically switches on. Furthermore, the collective fault signalling contact is activated. An external alarm (horn, SMS through SmartHome connection) can be triggered through the potential-free contact.

When the water drops below the high water level, the pump switches off after the set follow-up time. The alarm signal is acknowledged automatically.

#### 4.4 Operating principle

The sewage flows into the collection tank through the inlet pipe. When the water comes to the switch-on level, the pump switches on. The collected sewage is pumped into the connected discharge pipe. When the water comes to the switch-off level, the pump switches off after the set follow-up time. A pump cycling occurs each time the pump switches off.

When the water comes to the high water level, the two pumps switch on (forced switch-on). The high water LED or display shows an alarm signal. Also, the internal buzzer can emit a sound alarm signal. Furthermore, the output for the collective fault signal (SSM) activates.

#### 4.5 Operation with frequency converter

Operation with the frequency converter is not permitted.

#### 4.6 Type key

|                  |  |
|------------------|--|
| Example:         | <b>DrainLift SANI-L.17/T540/4C-CEE</b>   |
| <b>DrainLift</b> | Product family   |
| <b>SANI</b>      | Sewage lifting unit  |
| <b>L</b>         | Size   |
| <b>17</b>        | Max. delivery head in m at Q = 0   |
| <b>T</b>         | Mains connection: <ul style="list-style-type: none"> <li>• M = 1~</li> <li>• T = 3~</li> </ul>   |
| <b>540</b>       | Electrical Value: <ul style="list-style-type: none"> <li>• 5 = 50 Hz</li> <li>• 6 = 60 Hz</li> <li>• 23 = 230 V</li> <li>• 38 = 380 V</li> <li>• 40 = 400 V</li> </ul>   |
| <b>4</b>         | Motor and switchgear version: <ul style="list-style-type: none"> <li>• 1 = operating mode: S3, switchgear: Control MS-L</li> <li>• 4 = operating mode: S1, switchgear: Control EC-L</li> </ul>   |
| <b>C</b>         | Version for aggressive fluids  |
| <b>CEE</b>       | Plug: <ul style="list-style-type: none"> <li>• EF= CEE7/7 plug (Shockproof)</li> <li>• G = G type (UK)</li> <li>• I = I type (AU, NZ, ZH)</li> <li>• CEE = different CEE plugs (16 A/32 A, 3-poles; 32 A, 1-pole)</li> <li>• O= without cable</li> </ul> |

#### 4.7 Technical data

---

Approved field of application

---

|                                       |                             |
|---------------------------------------|-----------------------------|
| Max. pressure in the discharge pipe   | 6 bar (87 psi)              |
| Max. delivery head                    | See rating plate            |
| Max. volume flow                      | See rating plate            |
| Max. inlet height of the lowest inlet | 5 m (16.5 ft)               |
| Fluid temperature                     | 3 ... 40 °C (37 ... 104 °F) |
| Max. short-time fluid temperature     | 65 °C (149 °F), 5 min       |
| Ambient temperature                   | 3 ... 40 °C (37 ... 104 °F) |
| Protection class of lifting unit      | IP68 (2 mWs/7 d)            |
| Protection class of switchgear        | IP54                        |

## Electrical data

|                                    |   |
|------------------------------------|---|
| Power consumption [ $P_1$ ]        | See rating plate  |
| Rated power [ $P_2$ ]              | See rating plate  |
| Rated current [ $I_N$ ]            | See rating plate  |
| Speed [n]                          | See rating plate  |
| Activation type                    | Direct  |
| Operating mode (based on one pump) | <ul style="list-style-type: none"> <li>• SANI-L.../1...: S3 10% <ul style="list-style-type: none"> <li>– Cycle time: 10 min</li> <li>– Activation period: 1 min</li> <li>– Downtime: 9 min</li> </ul> </li> <li>• SANI-L.../4...: S1</li> </ul> |
| Max. switching frequency           | 120/h   |
| Cable length to plug               | 1.5 m (5 ft)  |
| Cable length to switchgear         | <ul style="list-style-type: none"> <li>• SANI-L.../1...: 4 m (13.2 ft)</li> <li>• SANI-L.../4...: 10 m (33 ft)</li> <li>• SANI-L.../4C...: 10 m (33 ft)</li> </ul>  |

## Connections

|                        |                      |
|------------------------|----------------------|
| Discharge port         | DN 80, PN 10         |
| Inlet connection       | DN/OD 110; DN/OD 160 |
| Ventilation connection | DN/OD 75             |
| Drain connection       | DN/OD 50             |

## Dimensions and weights

|   |   |
|---|---|
| Tank volume   | 122 l (32 US.liq.gal.)  |
| Max. usable volume in the tank according to the inlet height* | 60 l/16 US.liq.gal. (180 mm*)/76 l/20 US.liq.gal. (250 mm*)/91 l/24 US.liq.gal. (315 mm*) |
| Diagonal dimension  | 965 mm (38 in)  |
| Weight  | 66 ... 76 kg (145.5 ... 167.5 lb)   |
| Noise level   | 70 dB(A)  |

DrainLift SANI-L.../1...:

**The unit is not designed for continuous duty (operation mode S1). The max. volume flow applies to intermittent periodic duty (operation mode S3).**

DrainLift SANI-L.../4...:

**The unit is designed for continuous duty (operation mode S1). The max. volume flow applies to continuous duty (operation mode S1).**

#### 4.8 Manufacturer date

The date of production is shown according to ISO 8601: YYYYWww (e.g., 2020W53)

- YYYY = year
- W = abbreviation for week
- ww = calendar week

#### 4.9 Scope of delivery

- Lifting unit with switchgear and connection cable with plug
- Flange connector from DN 80, PN 10 to DN/OD 110
- Flexible collar DN/OD 110 for discharge connection
- HT double socket DN/OD 75 for ventilation connection
- HT double socket DN/OD 50 for drain connection
- Inlet set with hole saw 124 mm (5 in) and seal for HT pipe DN/OD 110

- Floor fixation set
- Noise insulation mat
- 9 V rechargeable battery
- Installation and operating instructions

#### 4.10 Accessories

##### On the discharge side

- Flange connector for connection of a discharge pipe
- Shut-off valve with flat seal and assembly material

##### On the inlet side

- Shut-off valve with fixed pipe ends
- Inlet seal and inlet set (seal and hole saw)

##### General

- Diaphragm hand pump
- 3-way stopcock for switching over to manual suctioning
- Signal horn
- Flash light

## 5 Transportation and storage

### 5.1 Delivery

- Immediately examine the shipment for defects (damage, completeness ...).
- Write all defects on the freight documentation.
- Tell the manufacturer about the defects on the day of receiving the shipment.
- Subsequent told claims can no longer be asserted.

### 5.2 Transport

The manufacturer supplies the lifting unit in applicable packaging. This packaging prevents damage during transport and storage.

- To prevent damage to the lifting unit during move, only remove the outer packaging at the installation site.
- Do not immerse the plug in fluid.
- Do not pull on the connection cable.
- Use leak-proof packaging for used lifting units, e.g., rip-proof plastic bags.

### 5.3 Storage



#### DANGER

##### Danger through bacterial infection!

The lifting unit collects and pumps sewage. There can be bacteria and hazardous germs in the tank. Follow these points:

- After removal, disinfect the lifting unit. Especially the inner side of the tank.
- Obey the factory regulations.

#### CAUTION

##### Property damage through water ingress in the connection cable!

Water in the connection cable destroys the cable. Water ingress in the connection cable can also cause total loss of the motor.

- Do not immerse the bare cable end in the fluid.
- Seal the bare cable end for storage.

Newly supplied lifting units can be stored for one year. For longer storage time, contact customer service.

When storing the pump, follow these points:

- Put the lifting unit securely on a hard surface and prevent it from slipping and falling over.
- Permitted storage temperature: -15 ... 60 °C (5 ... 140 °F), max. humidity: 90%, non-condensing.

It is recommended to use frost-proof storage. Storage temperature: 5 ... 25 °C (41 ... 77 °F), relative humidity: 40 ... 50%.

- Drain the collection tank fully.
- Coil up connection cables and attach to the motor.
- Seal open ends of the connection cables and plugs in a watertight manner.
- Obey the instructions for switchgear storage.

- Tightly seal all open connections.
- Do not keep the lifting unit in spaces where welding work is carried out. The caused gases or radiation can corrode the plastic and elastomeric parts.
- Prevent the lifting unit from direct sunlight and heat. Very high heat can damage the plastic parts.
- Elastomeric parts are subject to natural brittleness. Contact customer service if storage is necessary for more than 1 year.

## 6 Installation and electrical connection

### 6.1 Staff qualifications

- Electrical work: Only a qualified electrician must do the work.  
Necessary knowledge: identification and prevention of electrical hazards
- Installation and dismantling: Only a specialist in sanitary facilities must do the work.  
Necessary knowledge: fastening of the buoyancy safeguard, connection of plastic pipes

### 6.2 Installation types

- Floor-mounted installation in buildings
- Concealed-wall installation in buildings
- Concealed-floor installation in pump chambers outside buildings

### 6.3 Operator responsibilities

- Obey local accident prevention and safety regulations.
- Obey regulations for working below suspended loads when using lifting accessories.
- Supply protective equipment. Make sure that staff wears protective equipment.
- Obey local sewage technology regulations for the operation of sewage systems.
- Make sure there is access to the installation location.
- Structural components and foundations must be sufficiently stable for the device to be fixed in a safe and functional manner. The operator is responsible to supply correct structural component/foundation.
- Obey local regulations for the installation work.
- Make sure that the available consulting documents (installation plans, installation location, inflow conditions) are full and accurate.
- Obey the consulting documents to lay and prepare the pipes.
- To prevent the mains connection from flooding, mount the mains connection at a sufficient height.

### 6.4 Installation



#### WARNING

##### Risk of injury without protective equipment!

During work, there is a risk of (serious) injury to feet and hands.



- Wear safety gloves.
- Wear safety shoes.



#### CAUTION

##### Property damage through incorrect transport!

Do not move or set up the lifting unit alone. There is a risk of property damage.

- Always move and set up the lifting unit with two persons.

#### Building installation

- Obey EN 12056-4.
- Make sure that the operating space is sufficiently ventilated.
- Free space of min. 60 cm (2 ft) around the unit
- In case of an accident:  
Prepare pump sump in the operating space, min. dimensions: 500x500x500 mm (20x20x20 in). Use pump accordingly. Make sure that manual drainage is feasible.
- Make sure that all connection cables are laid properly. Prevent the connection cables from posing a risk (i.e. tripping, damage during operation). Examine if the cable cross-section and the cable length are sufficient for the selected installation type.
- The switchgear is not flood-proof. Install the switchgear at an sufficient height.

## Installation in a pump chamber



### DANGER

#### Danger through alone working!

Working in chambers, narrow rooms, and in areas with a risk of falling can be dangerous. Do not work alone.

- Only do this work with a second person.



### WARNING

#### Risk of injury without protective equipment!

During work, there is a risk of (serious) head injury.

- Wear safety helmet (if a lifting equipment is used).

### CAUTION

#### Property damage through frost!

Frost can cause malfunctions. Frost can also cause property damage.

- Make sure that the pump chamber and the discharge line are outside of the frost zone.
- If the pump chamber or the discharge line is in the frost zone, stop operating the system during frost times.

Also follow these points if the lifting unit is installed in a pump chamber:

- Toxic or asphyxiating gases can collect during work.
- If toxic or asphyxiating gases collect, go out of the workplace immediately.
- Be conscious of the diagonal dimension of the lifting unit.
- Install lifting accessory on flat, clean and hard surface. Make sure to get access to the storage area and installation location easily.
- Attach two transport straps to the lifting unit. Prevent the transport straps from slipping. Only use technically approved lifting slings.
- If it is no longer safe to work because of the weather conditions (e.g. ice formation, strong wind), stop work immediately.

#### 6.4.1 Note on fixation material

The lifting unit can be installed on different constructions (concrete and steel construction, etc.). Use the fixation material which is applicable for the related construction. For correct installation, follow these instructions for the fixation material:

- Prevent tearing or chipping of the construction surface, **follow the minimum edge distances**.
- Make sure that the installation is tight and safe, **follow the given drilling hole depth**.
- Drilling dust decreases holding strength, **always blow out or vacuum out the drilling hole**.
- Only use components (e.g. screws, anchors, mortar cartridges) which are in good condition.

#### 6.4.2 Note on pipework

The pipework has changing pressures during operation. Depending on the operating conditions, pressure peaks can occur (e.g., when closing the non-return valve), which can be multiples of the pump pressure. These changing pressures apply forces on the piping and the pipe connections. For safe and correct operation, design and examine the piping and pipe connections based on these points:

- Make sure that the pipes are self-supporting: No tensile or compressive forces are applied on the lifting unit.
- Consider the pressure resistance of pipework and pipe connections.
- Consider tensile strength of the pipe connections (= longitudinal force fit connection).
- Consider the pressure rating of the pipes.
- Make sure that pipes are connected without tension and vibrations.
- Install a gate valve on the inlet side and on the discharge pipe side downstream of the non-return valve.

#### 6.4.3 Work steps

Install the lifting unit in these steps:

- Preparing the installation.
- Installing the lifting unit.
- Connecting the discharge pipe.

#### 6.4.4 Preparing the installation

- Connecting the inlet.
- Connecting the ventilation pipe.
- Connecting a diaphragm hand pump to the drain connection.
- Unpack the lifting unit.
- Remove the transportation lock.
- Examine the scope of delivery.
- Examine that all components are in correct working condition. **CAUTION! Do not install defective components. Defective components can lead to system failures.**
- Put accessories aside and keep them for subsequent use.
- Prepare the installation location:
  - Horizontal and flat installation surface
  - Free space of min. 60 cm (2 ft) around the unit
  - Feasible fixation with dowels
  - Clean, free of coarse solids
  - Dry
  - Frost free
  - Sufficiently lit
- For concealed-wall installation, follow these points:
  - Inspection opening
  - Minimum distance between wall and the unit: 20 mm
  - Sufficient and regular air change for motor cooling **CAUTION! Not sufficient air change can lead to overheating of the motor and a possible decrease of function of the lifting unit.**
  - Ventilation of the lifting unit over the roof
  - Sufficient space for maintenance and repair: safe and easy access to tank opening, non-return valve, motor, and switchgear
- For concealed-floor installation, follow these points:
  - Sufficient space for maintenance and repair: safe and easy access to tank opening, non-return valve and motor
  - Ventilation of the lifting unit over the surface
  - Outdoor switch cabinet for installation of the switchgear

#### 6.4.5 Installing the lifting unit

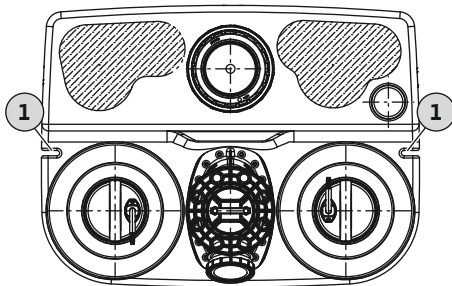

Fig. 2: Lifting unit top view

##### 1 Fastening grooves for floor anchoring

Install the lifting unit. Prevent the lifting unit from buoyancy and twisting. Anchor the lifting unit to the floor.

- ✓ Installation preparing work is done.
  - ✓ Installation location is prepared as shown in the consulting documents.
  - ✓ Applicable fixation material is given for the building floor. **NOTICE! Follow the information on the fixation material.**
1. Put the lifting unit at the installation location and align it to the pipework. **CAUTION! To prevent the switchgear from falling down, attach the switchgear to the lifting unit. The switchgear can break if dropped. NOTICE! Lifting unit must be upright.**
  2. Mark the drilling holes of the fastening grooves.
  3. Put the lifting unit aside.
  4. Drill and clean the holes. Put into the dowels.
  5. Lay and align the noise insulation mat.
  6. Put and align the lifting unit to the noise insulation mat.
  7. Put into the fastening screws and washers through the fastening grooves. Put the fastening screws into the dowels.
  8. Fasten the lifting unit to the floor.
  9. To prevent the switchgear from flooding, fasten the switchgear to the wall at a sufficient height (see switchgear instructions).
  10. Lay the connection cable. Obey applicable regulations.
    - ▶ Lifting unit is installed. Next step: Connecting the discharge pipe.

### 6.4.6 Connecting the discharge pipe

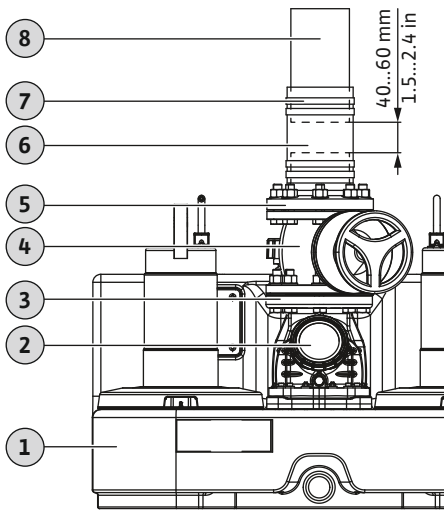

Fig. 3: Fitting discharge connection

|   |                  |
|---|------------------|
| 1 | Lifting unit     |
| 2 | Non-return valve |
| 3 | Discharge port   |
| 4 | Shut-off valve   |
| 5 | Flange connector |
| 6 | Flexible collar  |
| 7 | Pipe clamp       |
| 8 | Discharge pipe   |

Follow these points to connect the discharge pipe:

- Make sure that the discharge pipe is DN 80 or DN 100.
- Be conscious of the flow rate in the discharge pipe: 0.7 m/s (2.3 ft/s) to 2.3 m/s (7.5 ft/s).
- Do not decrease the pipe diameter.
- Make sure that all connections are fully tight.
- Install the discharge pipe as a “pipe loop” to prevent backflow from the primary public sewer.

At the highest point, the bottom edge of the pipe loop must be above the locally given backflow level.

- To prevent frost, install the discharge line sufficiently deep.
- Install a shut-off valve.

✓ The lifting unit is installed correctly.

✓ The discharge pipe is installed correctly as shown in the consulting documents.

✓ Assembly materials are prepared:

- 1x shut-off valve
- 1x flexible collar
- 4x pipe clamps
- 2x seals
- 8x screws, washers, nuts

1. Install the shut-off valve on the discharge port. **Tightening torque: 8 Nm (5.9 ft·lb).**
2. Install flange connector on the shut-off valve. **Tightening torque: 8 Nm (5.9 ft·lb).**
3. Put the pipe clamps to the flange connector.
4. Slide the flexible collar over the discharge pipe.
5. Slide the flexible collar over the flange connector.
  - ⇒ To make sure that the discharge pipe is connected in a sound-isolated manner, keep a 40 ... 60 mm (1.5 ... 2.4 in) distance between the end of the discharge pipe and the end of the flange connector.
    - If the distance is too small, decrease the length of the discharge pipe.
    - If the distance is too large, extend or replace the discharge pipe.
6. Align the flexible collar centrally between the flange connector and the discharge pipe.
7. Fasten the flexible collar to the flange connector and discharge pipe with two pipe clamps each. **Tightening torque: 5 Nm (3.7 ft·lb).**
  - ▶ Discharge pipe is connected. Next step: Connecting the inlet.

### 6.4.7 Connecting the inlet

The inlet can be located in the areas indicated on the rear wall, both side walls and the tank roof, as desired.

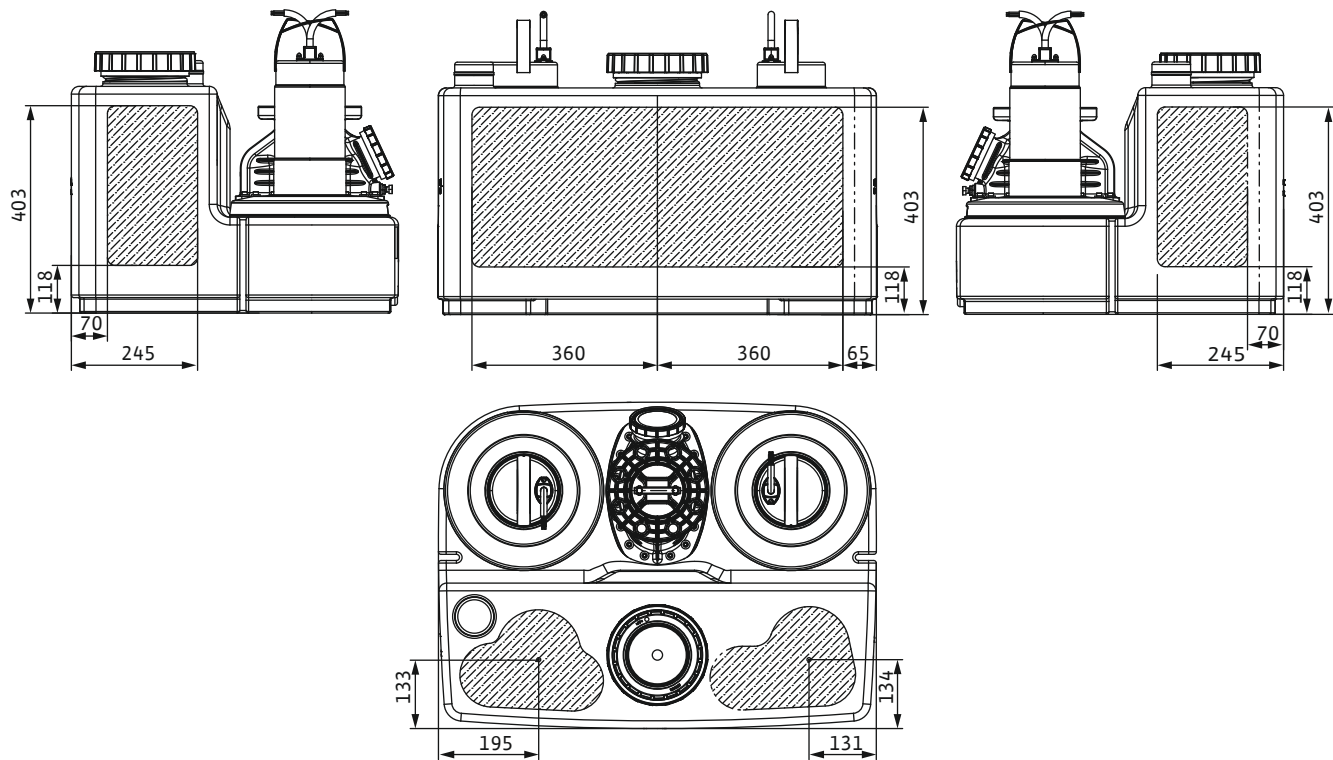

Fig. 4: Inlet areas

Follow these points to connect the inlet:

- Only connect the inlet in the areas shown. Installing the inlet outside these areas can cause:
  - Leaking connections
  - Backflow into the inlet pipe
  - Impaired function of the lifting unit
- To prevent surging inflow or air intake into the collection tank, install the inlet correctly. **CAUTION! Surging inflow or air intake into the collection tank can lead to malfunctions of the lifting unit.**
- To permit the inlet pipe to drain off by itself, install the inlet pipe with a slope gradient to the lifting unit.
- Be conscious of the minimum inlet height (from floor to the centre of the inlet pipe): 180 mm (7 in).
- Make sure that all connections are fully tight.
- Install a shut-off valve in the inlet pipe.

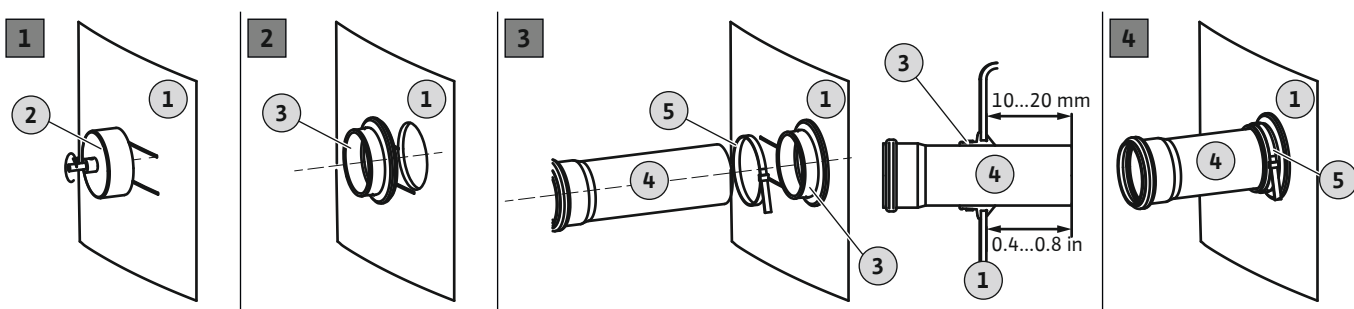

Fig. 5: Connecting the inlet

|   |                    |
|---|--------------------|
| 1 | Tank wall          |
| 2 | Hole saw for drill |
| 3 | Inlet seal         |
| 4 | Inlet pipe         |
| 5 | Pipe clamp         |

- ✓ Lifting unit is installed correctly.
- ✓ Inlet pipe is installed to the collection tank. The consulting documents are obeyed.
- ✓ Installation material are prepared:
  - 1x hole saw 124 mm (5 in)
  - 1x seal DN/OD 110
  - 1x pipe clamp



1. Mark the inlet on the collection tank.
2. Cut the hole with the hole saw into the tank wall.  
To drill the hole, follow these points:
  - Obey the dimensions of the inlet area. **CAUTION! The drilled hole must be fully in the identified inlet area.**
  - Max. speed of the drill: 200 rpm.
  - Examine the hole diameter. **NOTICE! Drill the hole carefully. Impermeability of the connection depends on the drilled hole.**
  - Make sure that the drilling chips fall cleanly from the hole saw. If the drilling chips attach to the hole saw, the material heats up too quickly and melts. If the material melts, obey these instructions:
    - ⇒ Stop drilling, let the material cool down, and clean the hole saw.
    - ⇒ Decrease the drilling speed.
    - ⇒ Adjust feed rate during drilling.
3. Deburr the cut edge and make it smooth.
4. Put the seal into the hole.
5. Push the pipe clamp on the seal.
6. Coat the inner surface of the seal with lubricant.
7. Push the inlet pipe into the seal.  
Push the inlet pipe 10 ... 20 mm (0.4 ... 0.8 in) into the collection tank.
  - ⇒ Obey the value specification, or else the function of the lifting unit can be impaired.
8. Fasten the seal and the pipe with the pipe clamp. **Tightening torque: 5 Nm (3.7 ft·lb).**
  - ▶ Inlet is connected. Next step: Connecting the ventilation pipe.

#### 6.4.8 Connecting the ventilation pipe

The connection of a ventilation pipe is mandatory. Furthermore, ventilation is necessary to make sure that the lifting unit functions correctly. Follow these points to connect the ventilation pipe:

- For floor-mounted or concealed-wall installation in buildings, route the ventilation pipe over the roof of the building.
- For concealed-floor installation (underground installation) outside buildings, route the ventilation pipe over the surface.
- Make sure that all connections are fully tight.

|   |                        |
|---|------------------------|
| 3 | Ventilation connection |
| 4 | Discharge port         |

- ✓ Lifting unit is installed.
  - ✓ Ventilation pipe is laid.
1. Put the HT double socket on the open ventilation connection.
  2. Put the ventilation pipe into the HT double socket.
    - ▶ Ventilation pipe is installed. Next step: Connecting a diaphragm hand pump to the drain connection (when it is necessary for emergency drainage).

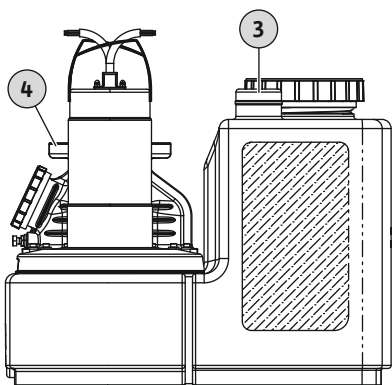

Fig. 6: Collection tank ventilation connection

#### 6.4.9 Installation of a diaphragm hand pump



#### NOTICE

##### Do not connect inlets to the drain connection!

For maintenance work or if a system malfunctions, the tank is emptied through the drain connection. If an inlet is connected to the drain connection, the tank cannot be emptied.

Manually pump out the collection tank for maintenance or if the lifting unit malfunctions. It is recommended to install a diaphragm hand pump. **CAUTION! If the lifting unit malfunc-**

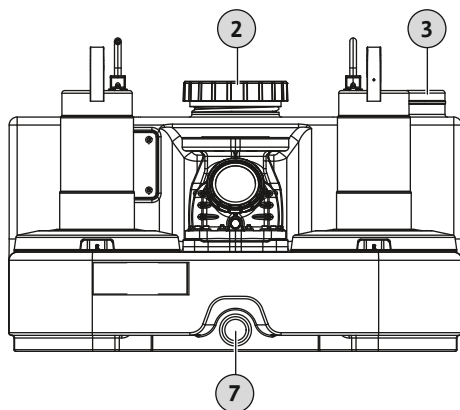

Fig. 7: Connection of diaphragm hand pump

tions, backflow into the inlet can break the collection tank. Shut off the inlet and drain the collection tank.

|   |  |
|---|--|
| 2 | Inspection opening of collection tank  |
| 3 | Collection tank ventilation connection |
| 7 | Drain connection                       |

Follow these points to install a diaphragm hand pump:

- Obey the installation and operating instructions for the diaphragm hand pump.
  - Make sure that all connections are fully tight.
  - ✓ Installation height for optimum operation is set.
1. Use a 30 mm (1.3 in) hole saw to drill the drain connection.
  2. Put the HT double socket on the open drain connection.
  3. Connect the inlet of the diaphragm hand pump to the HT double socket on the drain connection.
  4. Connect the outlet of the diaphragm hand pump to the discharge line above the shut-off valve. Alternatively, connect the outlet of the diaphragm hand pump through a pipe loop directly to the sewer.
    - ▶ Diaphragm hand pump is installed.

## 6.5 Electrical connection



### DANGER

#### Danger of death through electrical shock!

Incorrect behaviour during electrical work results in death by electric shock.

- Only a qualified electrician must do the electrical work.
- Obey local regulations.

### 6.5.1 Fuse on mains side

#### Circuit breaker

- Make sure the type and switching characteristics of the circuit breakers are compatible with the rated current of the connected product.
- Obey local regulations.

| Lifting unit         | Max. rated current (when high water alarm activated) | Fuse protection (recommended characteristic: C) |
|----------------------|--|---|
| Single-phase current |  |   |
| SANI-L.11M...        | 18.6 A   | 20 A  |
| SANI-L.12M...        | 14.4 A   | 16 A  |
| SANI-L.16M...        | 18.6 A   | 20 A  |
| Three-phase current  |  |   |
| SANI-L.11T...        | 7.2 A  | 10 A  |
| SANI-L.12T...        | 5.8 A  | 10 A  |
| SANI-L.16T...        | 7.2 A  | 10 A  |
| SANI-L.17T...        | 11 A   | 16 A  |
| SANI-L.19T...        | 17 A   | 20 A  |
| SANI-L.21T...        | 11 A   | 16 A  |
| SANI-L.23T...        | 19.6 A   | 20 A  |

#### Residual-current device (RCD)

- If persons can touch the device and conductive fluids, install a residual-current device (RCD).
- Obey the regulations of the local energy supplier for the residual-current device (RCD).

### 6.5.2 Mains connection

- Follow the information on the rating plate.
- Earth the device. Obey local regulations.
- To prevent the socket from flooding, install it at a sufficient height.

#### Socket type:

##### Single-phase current:

- DrainLift SANI-L.11M...: CEE 32A, 1P+N+PE, 6 h
- DrainLift SANI-L.12M...: CEE 7/7 (Schuko)

- DrainLift SANI-L.16M... : CEE 32A, 1P+N+PE, 6 h

**Three-phase current:**

- DrainLift SANI-L...T/1...: CEE 16A, 3P+N+PE, 6 h, clockwise rotating field
- DrainLift SANI-L...T/4...: CEE 32A, 3P+N+PE, 6 h, clockwise rotating field

### 6.5.3 Switchgear

The switchgear is pre-wired and factory-set. Obey local regulations to lay all connection cables to the switchgear and mains connection. **CAUTION! To prevent the switchgear from flooding, install it at a sufficient height.**

The switchgear has these basic functions:

- Level-dependent control
- Motor protection
- Direction-of-rotation monitoring (only for the three-phase current)
- High water alarm

For detailed information, refer to the installation and operating instructions for the switchgear:



- Electrical connection of the lifting unit to the switchgear
- Overview and description of functions
- Setting of the switching points

#### Switching points

The switching points of the lifting unit can be adjusted to the inlet height of the lowest inlet. This results in a larger usable volume. The switching point data always refers to the floor. **NOTICE! If the inlet is below the permitted inlet height, there is a risk of a permanent backflow into the inlet pipe.**

#### Wilo-Control MS-L switchgear

For the Wilo-Control MS-L switchgear, set the switching points through fixed switch positions of DIP switch 3:

| Switching points               | Setting<br>DIP switch 3   | Factory setting/se-<br>lectable |
|--------------------------------|---|---------------------------------|
| Inlet height: 180 mm (7 in)    |  | •                               |
| Inlet height: 250 mm (10 in)   |  | o                               |
| Inlet height: 315 mm (12.5 in) |  | o                               |

#### Key

- = factory setting, o = adjustable

**NOTICE! For the location of DIP switch 3, refer to the installation and operating instructions for the switchgear.**

#### Wilo-Control EC-L switchgear

For the Wilo-Control EC-L switchgear, set the switching points through the values in the menus:

| Switching points               | Factory setting/se-<br>lectable | Menu 5.09 | Menu 1.12 | Menu 1.13 | Menu 1.14 | Menu 1.15 | Menu 5.51 |
|--------------------------------|---------------------------------|-----------|-----------|-----------|-----------|-----------|-----------|
| Inlet height: 180 mm (7 in)    | •                               | 1.00      | 0.46      | 0.19      | 0.49      | 0.28      | 0.53      |
| Inlet height: 250 mm (10 in)   | o                               | 1.00      | 0.69      | 0.19      | 0.73      | 0.28      | 0.76      |
| Inlet height: 315 mm (12.5 in) | o                               | 1.00      | 0.90      | 0.19      | 0.93      | 0.28      | 0.96      |

#### Key

- = factory setting, o = adjustable, switching point unit: Metres (m)

**NOTICE! For functional details and a description of the menu, refer to the installation and operating instructions for the switchgear.**

#### 6.5.4 Operation with frequency converter

Operation with the frequency converter is not permitted.

## 7 Commissioning



### WARNING

#### Risk of injury without protective equipment!

During work, there is a risk of (serious) foot injury.

- Wear safety shoes.



### NOTICE

#### Automatic switching on after power blackout

A switchgear controlled the product. The product is automatically switched on and off depending on the application.

The product can start automatically after a power blackout.

#### 7.1 Staff qualifications

- Operation/control: The staff knows how to operate the system.

#### 7.2 Operator responsibilities

- Supply installation and operating instructions with the lifting unit or keep the instructions at a dedicated location.
- Make sure that staff reads and understands the installation and operating instructions.
- Examine safety devices and emergency stop circuits. Make sure that safety devices and emergency stop circuits are active and function correctly.
- Make sure that the lifting unit is applicable for the given operating conditions.

#### 7.3 Operation

### CAUTION

#### System malfunction through incorrect switchgear operation mode!

When the plug is connected to the socket, the switchgear starts in the operation mode set before. An incorrect operation mode can result in system malfunction.

- Do not put the plug into the socket. Read the operating instructions of the switchgear.
- Only put the plug into the socket when you know how to use the switchgear.

The lifting unit is operated by the switchgear. The switchgear is pre-set for the lifting unit. Obey the installation and operating instructions for the switchgear to make sure of correct operation:

- Settings
- LED displays/LC display
- Alarm signals

#### 7.4 Test run

Do a test run before operating the lifting unit in automatic mode. A test run examines the correct functioning and impermeability of the unit. If necessary, adjust the pump's follow-up time to make sure of the optimum operation of the unit

- ✓ Lifting unit is installed correctly.
  - ✓ Connections are checked for correctness.
1. Activate the lifting unit: Put the plug into the socket.
  2. Set automatic mode on the switchgear.
  3. Open the shut-off valve in the discharge pipe. **NOTICE! Keep the shut-off valve in the inlet closed.**
  4. Unscrew the inspection cover on the collection tank.
  5. Slowly fill the collection tank with water through the inspection opening with a hose. **NOTICE! Risk of malfunction! Do not hold water jet directly above the float switch.**
  6. Switch on and off the lifting unit through level control device.
    - ⇒ Do no less than two full pumping operations of all pumps for a test run.

⇒ To examine the duty point, fill the discharge pipe fully with water. Do more test runs until the discharge pipe is fully filled.

7. Screw the inspection cover on. **NOTICE! Tightly seal the inspection opening on the collection tank.**
8. Examine all connections for impermeability.
  - ⇒ If all connections are leak-proof, the lifting unit can run in automatic mode.
  - ▶ Test run is completed.
  - ▶ Lifting unit **is commissioned**: Keep shut-off valve open in the **discharge pipe**.
  - ▶ Lifting unit **is in standby mode**: Close the shut-off valve in the **discharge pipe**.

## 7.5 Follow-up time

The follow-up time is pre-set at the factory to 3 seconds. Adjust the follow-up time as necessary for these points:

- Increasing the usable volume for each pumping process.
- Extensive suction of settling sediments at the bottom of the tank through integrated deep suction.
- Slurping operation to prevent pressure surges.

To set the follow-up time, read the installation and operating instructions for the switchgear.

**CAUTION! Be conscious of the operating mode if the follow-up time is changed. The operating mode shows the duty time and the standby time.**

## 7.6 Setting the venting screw

The non-return valve is equipped with a venting screw. The non-return valve can be opened via the venting screw for inspection. As a result, the remaining fluid can flow back into the collection tank from the discharge pipe. Restore the factory setting of the venting screw to ensure proper operation of the non-return valve.

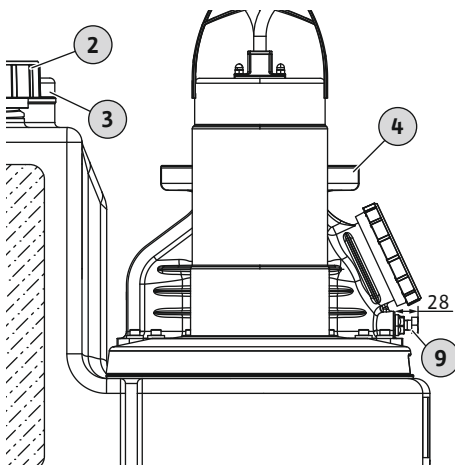

Fig. 8: Position of the venting screw

|   |  |
|---|--|
| 2 | Inspection opening of collection tank  |
| 3 | Collection tank ventilation connection |
| 4 | Discharge port                         |
| 9 | Venting screw                          |

✓ Lifting unit in standby mode.

1. Check factory setting of the venting screw: 28 mm (1.1 in)
2. Unscrew the venting screw if it is screwed in too far (> 28 mm/1.1 in).

**CAUTION! If the venting screw is screwed in too far, this causes damage to the non-return valve. This also leads to loud noises!**

## 8 Operation

The lifting unit operates in automatic mode by default and is switched on and off through the integrated level control device.



### WARNING

#### Risk of burns from hot surfaces!

During operation, the motor housing can get hot. There is a risk of skin burns if component is touched.

- Cool down the motor to ambient temperature after switching off.

- ✓ Commissioning is done.
- ✓ Test run is done.
- ✓ The handling and functioning of the lifting unit are known.
- ✓ Discharge pipe is fully filled with water.

1. Activate the lifting unit: Put the plug into the socket.
2. Set automatic mode on the switchgear.
3. Open the shut-off valve in the inlet and discharge pipe.
  - ▶ The lifting unit operates in automatic mode and is controlled depending on level.

## 8.1 Application limits

Incorrect operating conditions can result in overload or property damage to the lifting unit. Obey these operating limits:

- Max. inlet height of the lowest inlet: 5 m (16 ft)
- Max. pressure in the discharge pipe: 6 bar (87 psi)
- Fluid temperature: 3 ... 40 °C (37 ... 104 °F)
- Max. short-time fluid temperature: 65 °C (149 °F), 5 min
- Ambient temperature: 3 ... 40 °C (37 ... 104 °F)
- Maximum switching frequency: 120/h
- Operating mode:
  - SANI-L ... /1 ...: S3 10%
  - SANI-L ... /4 ...: S1

## 8.2 During operation

### CAUTION

#### Property damage through pressure surges!

Pressure surges can occur when switching off the pump. These pressure surges can damage the discharge pipe and the lifting unit.

- Increase the follow-up time to prevent pressure surges. A longer follow-up time results in slurping operation. In slurping operation, the non-return valve closes more smoothly.



### NOTICE

#### System malfunction through low delivery head!

If the delivery head is lower than 2 metres, the non-return valve does not close correctly. This lower counter pressure causes in a backflow of the fluid into the tank. This backflow results in a frequently switching on and off of the lifting unit, which can lead to a malfunction.

- Open shut-off valves in the inlet and the discharge pipe.
- Make sure that the maximum inflow is less than the maximum output of the system.
- Do not open inspection openings on the collection tank and the non-return valve.
- Make sure that the collection tank is sufficiently ventilated.

## 8.3 Emergency operation

### 8.3.1 Level control failure

If the level control fails, drain the collection tank in manual mode. For all related information on manual mode, refer to the installation and operating instructions for the switchgear.

### 8.3.2 Lifting unit failure

If the lifting unit fully fails, pump out the sewage using a diaphragm hand pump.

1. Close the shut-off valve in the inlet.
2. Close the shut-off valve in the discharge pipe.
3. Pump sewage into the discharge pipe using the diaphragm hand pump.

### 8.3.3 Flooding of the lifting unit (accident)



### DANGER

#### Danger through harmful fluid!

In case of an accident, the collected sewage flows into the operating space. There is a risk of a bacterial infection. Follow these points:

- Wear protective equipment:
  - One-way protective coverall
  - Sealed safety glasses
  - Respiratory mask
- Clean and disinfect all equipment (e.g., diaphragm hand pump, hoses) after use.
- Disinfect the lifting unit and operating space.
- Dispose of rinsing water to the sewer
- Obey local regulations to dispose of protective clothing and cleaning material.
- Obey the factory regulations.



## NOTICE

### Use of the lifting unit in a flood

The switchgear is not waterproof. To make sure that the lifting unit works correctly in a flood, follow these points:

- Install the electrical connections and switchgear at a flood-proof height.
- Obey the maximum flooding level and flooding time for the lifting unit.

## 9 Shutdown/dismantling

### 9.1 Staff qualifications

- Operation/control: The staff knows how to operate the system.
- Electrical work: Only a qualified electrician must do the work.  
Necessary knowledge: identification and prevention of electrical hazards
- Installation and dismantling: Only a specialist in sanitary facilities must do the work.  
Necessary knowledge: fastening of the buoyancy safeguard, connection of plastic pipes

### 9.2 Operator responsibilities

- Obey local accident prevention and safety regulations.
- Supply protective equipment. Make sure that staff wears protective equipment.
- Ventilate closed rooms.
- Toxic or asphyxiating gases can collect in closed rooms or buildings. Wear protective equipment (e.g., gas detector). Obey the factory regulations.
- Do not work alone in closed rooms. Only do this work with a second person.
- Obey regulations for working below suspended loads when using lifting accessories.

### 9.3 Shutdown

1. Close the shut-off valve in the inlet pipe.
2. Switch the switchgear to standby mode.
3. Drain the collection tank.  
Activate the lifting unit in manual mode and drain the collection tank.
4. Close the shut-off valve in the discharge pipe.
5. Switch off the lifting unit.  
Pull the plug out of the socket. **CAUTION! Prevent the lifting unit from not approved reactivation.**
  - ▶ The lifting unit is now decommissioned.

If the lifting unit is decommissioned for an extended time, do a functional check at regular intervals (quarterly). **CAUTION! Do the functional check as described in "Test run".**

### 9.4 Removal



## DANGER

### Danger through harmful fluid!

In case of an accident, the collected sewage flows into the operating space. There is a risk of a bacterial infection. Follow these points:

- Wear protective equipment:
  - One-way protective coverall
  - Sealed safety glasses
  - Respiratory mask
- Clean and disinfect all equipment (e.g., diaphragm hand pump, hoses) after use.
- Disinfect the lifting unit and operating space.
- Dispose of rinsing water to the sewer
- Obey local regulations to dispose of protective clothing and cleaning material.
- Obey the factory regulations.



## DANGER

### Danger of death through electrical shock!

Incorrect behaviour during electrical work results in death by electric shock.

- Only a qualified electrician must do the electrical work.
- Obey local regulations.



## DANGER

### Danger through alone working!

Working in chambers, narrow rooms, and in areas with a risk of falling can be dangerous. Do not work alone.

- Only do this work with a second person.



## WARNING

### Risk of burns from hot surfaces!

During operation, the motor housing can get hot. There is a risk of skin burns if component is touched.

- Cool down the motor to ambient temperature after switching off.

- ✓ The lifting unit is decommissioned.
  - ✓ Protective equipment put on.
  - ✓ All shut-off valves are closed.
1. Drain the discharge pipe into the tank. Open the non-return valve using the ventilation screw.
  2. Pump out the remaining fluid using the diaphragm hand pump.
  3. Remove the inlet connection: Pull the inlet pipe out of the inlet seal.
  4. Remove the discharge pipe connection: Remove the flexible collar.
  5. Remove the ventilation connection: Pull the ventilation pipe out of the HT double socket.
  6. Remove the drain connection: Remove the suction line of the diaphragm hand pump from the drain connection. **DANGER! Risk of health because of contact with sewage. The remaining sewage goes out of the collection tank through the drain connection. Collect sewage in applicable tanks and dispose of it into the sewer system.**
  7. Loosen the floor anchoring.
  8. Pull the lifting unit carefully out of the pipework.
    - ▶ The lifting unit is disassembled. Next step: Cleaning and disinfecting the lifting unit and the working area.

## 9.5 Clean and disinfection



## DANGER

### Danger through harmful fluids!

Disinfect the lifting unit after disassembly. Wear protective equipment when cleaning:

- Sealed safety glasses
- Respiratory mask
- Safety gloves
  - This protective equipment is the necessary basic equipment.
  - Obey the factory regulations.



- ✓ The lifting unit is dismantled.
  - ✓ The switchgear is packed watertight.
  - ✓ Washing water is flushed into the sewer complying with local regulations.
  - ✓ A disinfectant complying with factory regulations is available. **NOTICE! Obey the manufacturer's specifications for use.**
1. Flush the lifting unit with clean water from top to bottom.
  2. Open and flush the inspection opening on the collection tank and the non-return valve.
  3. Flush all connection ports from the inner side.
  4. Flush all dirt remained on the floor into the sewer.
  5. Let the lifting dry out.
  6. Close the inspection opening on the collection tank and non-return valve again.



- 10 Maintenance and repair**
- Maintenance and repair work can **only** be carried out by qualified staff (e.g. customer service). The maintenance intervals in accordance with EN 12056-4:
- ¼ year for commercial operations
  - ½ year for multi-residential buildings
  - 1 year for detached houses
- Record all maintenance and repair work in a log. The log must be signed by the qualified staff and the operator.
- Perform a test run after the maintenance work.
- 10.1 General overhaul**
- During the general overhaul, the motor bearings, shaft sealings, O-rings and connection cables are checked for wear and damage. Damaged components are replaced with original parts. This makes sure that the operation is correct.
- The general overhaul is done by the manufacturer or an approved service centre.
- 11 Spare parts**
- Order spare parts through customer service. To prevent return queries and incorrect orders, always supply the serial or article number. **Subject to change without prior notice.**
- 12 Disposal**
- 12.1 Protective clothing**
- Obey local regulations to dispose of worn protective clothing.
- 12.2 Operating fluids**
- Collect operating fluids in dedicated tanks.
  - Immediately clean up the leaked liquid.
  - Obey local regulations to dispose of the operating fluids.
- 12.3 Information on the collection of used electrical and electronic products**
- To prevent damage to the environment and human health, make sure to dispose of and recycle this product correctly.



### NOTICE

#### Do not dispose of the product in domestic waste!

This symbol means do not dispose of the product in domestic waste. The symbol is applied on the product or on the packaging.

Follow these points for a correct disposal of the product:

- Only return the product to a designated and permitted collection point.
- Obey local regulations.

Consult your local municipality, the nearest waste disposal site, or your retailer for a correct disposal. See for more <http://www.wilo-recycling.com> information about recycling.





# wilo



Local contact at  
[www.wilo.com/contact](http://www.wilo.com/contact)

Pioneering for You

WILO SE  
Wilopark 1  
44263 Dortmund  
Germany  
T +49 (0)231 4102-0  
T +49 (0)231 4102-7363  
[wilo@wilo.com](mailto:wilo@wilo.com)  
[www.wilo.com](http://www.wilo.com)