



WILO Mather and Platt – Atmos ISO FF (UL firefighting) Pumps

en Installation and Operating Instructions

Disclaimer

WILO Mather and Platt is very grateful for your interest in its products. The basic objective of this document is to provide instructions for maintaining and operating WILO Mather and Platt Atmos ISO FF pumps. Instructions are compiled for the person having a working knowledge of End Suction pumps and the pumps shall be installed under expert supervision and guidance.

With this document WILO Mather and Platt does not accept any liability for inaccurate installation, operation, or maintenance of the product at site. The authorities that install and maintain the pump shall be responsible for hassle free installation operation or maintenance of the product.

This document is prepared with at most care to ensure correct and accurate information, enabling the user to have trouble free installation and operational support. However, there can be few areas for improvement to make this document error free.

We welcome your valuable suggestions to make this document complete in all respects.

Plant Location -
Pump Type -
So. No. -
Q (m ³ /hr.) -
H (m) -
N (rpm) -
P kW -
Imp. Dia. -
Note: To be filled by the Customer

WILO Mather and Platt Pumps Pvt. Ltd.

Mumbai-Pune Road, Chinchwad,
Pune- 411 019, Maharashtra (India)

Tel: +91 20 27442100/1/2/3/4,

Toll Free Service: 1-800-266-8866

Fax: +91 2027442111

service.in@wilo.com

www.wilo.in

Fig.1: Pump Handling (Bare Pump and Pump with Motor / Engine) [Page No. 9, Point No. 3.1]

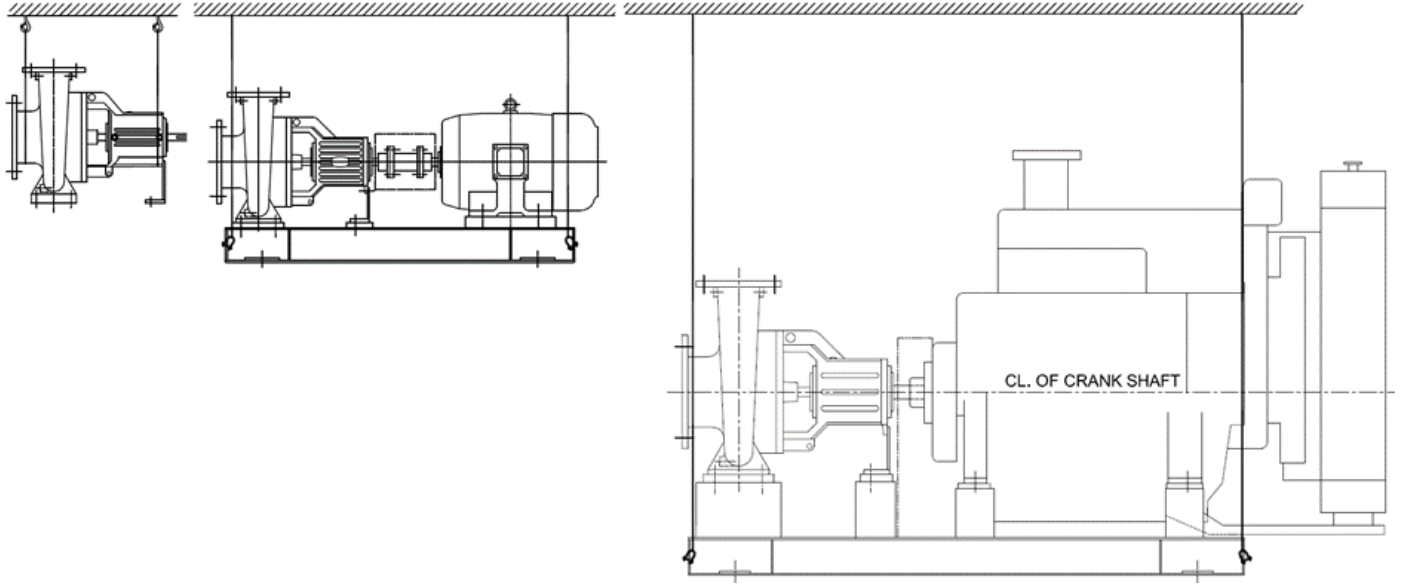

Fig.2: Engine Driven Pump [Page No.11, Point No. 6.1.2]

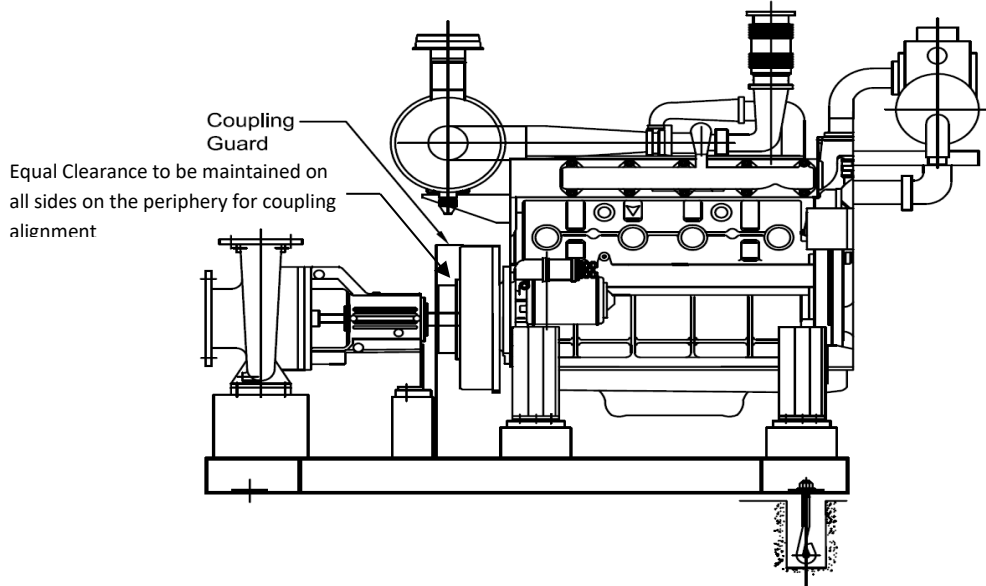

Fig.3: Pump Foundation [Page No.15, Point No. 7.2.1]

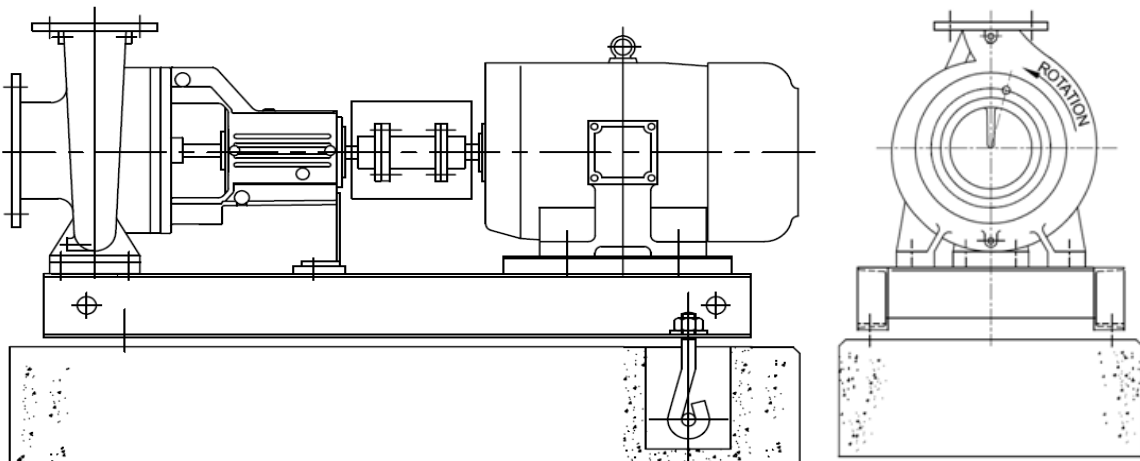

Fig.4: Leveling of Base-plate [Page No.15, Point No. 7.2.2]

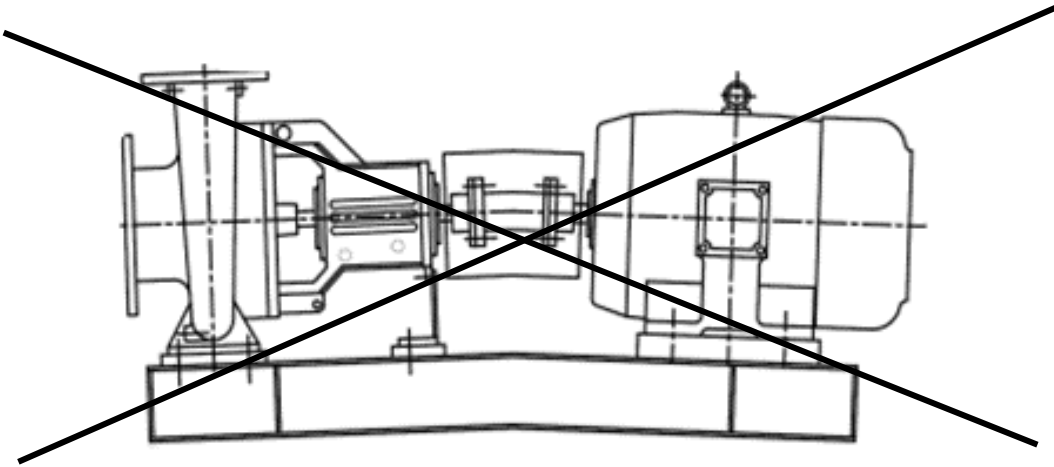

Fig.5: Coupling Alignment [Page No.16, Point No. 7.2.3]

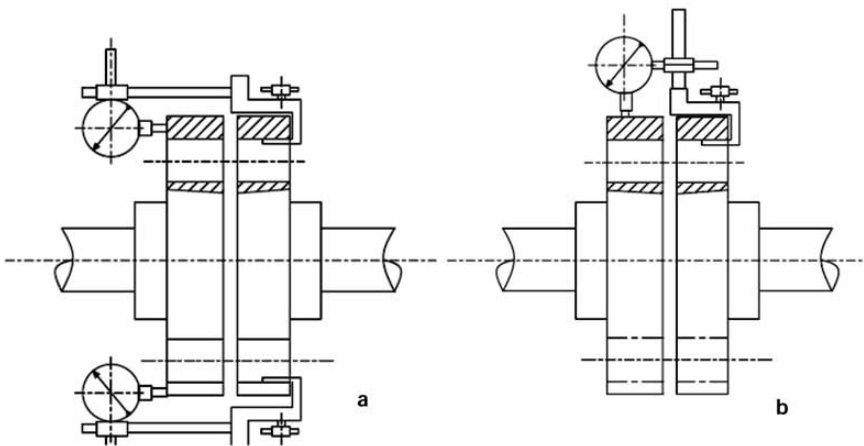
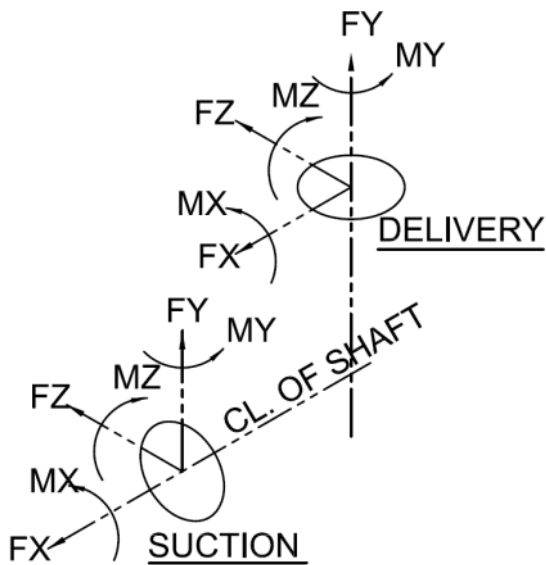
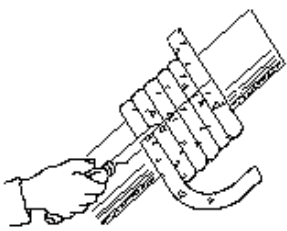
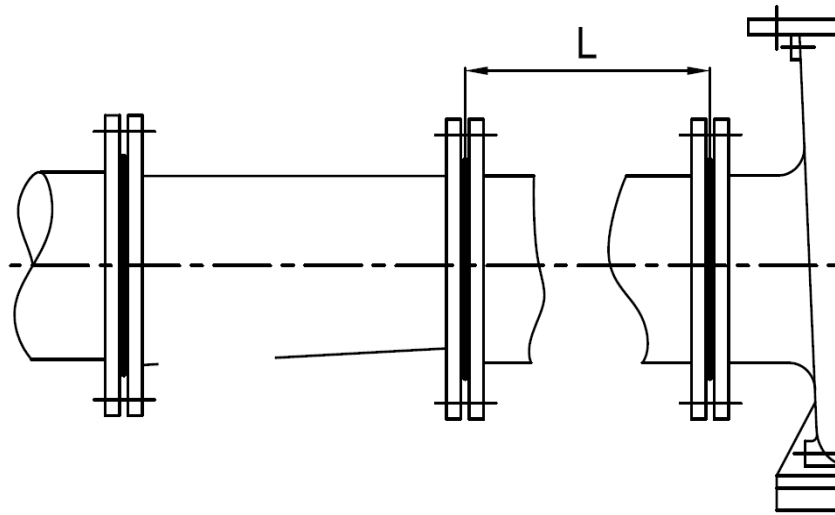
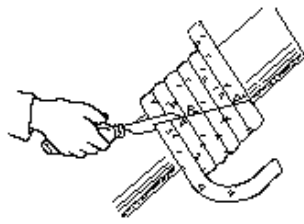

Fig.6: Forces and Moments [Page No.17, Point No. 7.2.4]





6a



6b

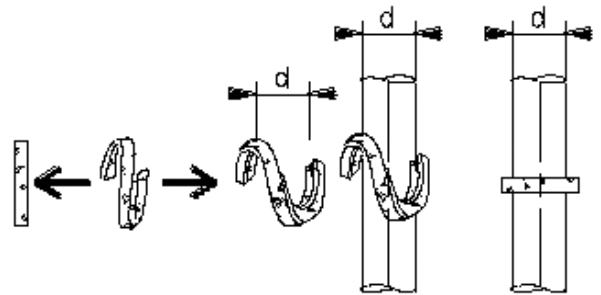

6c

1	General information	7
2	Safety	7
2.1	Designation of information in the operating instructions	7
2.2	Personnel qualifications	7
2.3	Danger in event of non-observance of the safety instructions	7
2.4	Safety consciousness on the job	7
2.5	Safety instructions for the operator	7
2.6	Safety instructions for installation and maintenance work	8
2.7	Unauthorized modification and manufacture of spare parts	8
2.8	Improper use	8
2.9	Safety & control devices	8
3	Transport and interim storage	8
3.1	Handling	8
3.2	Delivery	9
3.3	Storage	9
3.4	Pump returning back to the supplier	9
4	Intended use	9
5	Product information	9
5.1	Data plate	9
5.2	Type key	10
5.3	General description	10
5.4	Scope of delivery	10
5.5	Accessories	10
6	Description and function	10
6.1	Description of the product	10
7	Installation and electrical connection (Motor / Pump coupling system)	12
7.1	Installation of bare shaft pump	12
7.2	Installation of the complete pump set	13
8	Commissioning	16
8.1	Cleaning prior to start	16
8.2	Filling and venting	17
8.3	Starting the pump	18
9	Maintenance	19
9.1	Routine maintenance and frequency of inspection	19
9.2	Overhaul maintenance	20
9.3	Disassembling the pump	20
9.4	Reassembling the pump	21
9.5	Recommended spare parts	22
10	Faults, causes and remedies	23
11	Decommissioning and recycling	23
12	Recommended Oil Grade	24
13	Acceptable field vibration limit charts	24
14	Annexures-1 Cross Sectional Drawings	25
15	Annexures-2 Pre- Commissioning & Commissioning formats	28

CERTIFICATE OF COMPLIANCE

Certificate Number UL-US-2311805-0
Report Reference EX28996-20230327
Date 28-Mar-2023

Issued to: WILO Mather and Platt Pumps Pvt. LTD
Survey. No. 162
Mumbai - Pune Road Chinchwad, Pune, Maharashtra
411019
India

This is to certify that QWZU - Centrifugal Fire Pumps, End Suction
representative samples of See Addendum Page for Product Designation(s).

Have been evaluated by UL in accordance with the
Standard(s) indicated on this Certificate.

Standard(s) for Safety: ANSI/CAN/UL 448, Edition: 12, Issue Date: 2020-3-30,
Revision Date: 2022-12-7

Additional Information: See the UL Online Certifications Directory at
<https://iq.ulprospector.com> for additional information

This Certificate of Compliance indicates that representative samples of the product described in the certification report have met the requirements for UL certification. It does not provide authorization to apply the UL Mark. Only the Authorization Page that references the Follow-Up Services Procedure for ongoing surveillance provides authorization to apply the UL Mark.

Only those products bearing the UL Mark should be considered as being UL Certified and covered under UL's Follow-Up Services.

Look for the UL Certification Mark on the product.



Deborah Jennings-Conner, VP Regulatory Services

UL LLC

Any information and documentation involving UL Mark services are provided on behalf of UL LLC (UL) or any authorized licensee of UL. For questions, please contact a local UL Customer Service Representative at <http://ul.com/about/locations/>



CERTIFICATE OF COMPLIANCE

Certificate Number UL-US-2311805-0
Report Reference EX28996-20230327
Date 28-Mar-2023

This is to certify that representative samples of the product as specified on this certificate were tested according to the current UL requirements

Model	Category Description
Atmos_ISO FF 100-200	Centrifugal Fire Pumps, End Suction
Atmos_ISO FF 100-250	Centrifugal Fire Pumps, End Suction
Atmos_ISO FF 50-250	Centrifugal Fire Pumps, End Suction
Atmos_ISO FF 65-160	Centrifugal Fire Pumps, End Suction
Atmos_ISO FF 65-200	Centrifugal Fire Pumps, End Suction
Atmos_ISO FF 65-250	Centrifugal Fire Pumps, End Suction
Atmos_ISO FF 65-315	Centrifugal Fire Pumps, End Suction
Atmos_ISO FF 80-250	Centrifugal Fire Pumps, End Suction

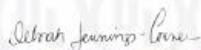

Deborah Jennings-Conner, VP Regulatory Services

UL LLC

Any information and documentation involving UL Mark services are provided on behalf of UL LLC (UL) or any authorized licensee of UL. For questions, please contact a local UL Customer Service Representative at <http://ul.com/about/ullocations>.



1 General information

The language of the original operating instructions is English. All other languages of these instructions are translations of the original operating instructions.

These installation and operating instructions are an integral part of the product. They must be kept readily available at the place where the product is installed. Strict adherence to these instructions is a precondition for the proper use and correct operation of the product.

These installation and operating instructions correspond to the relevant version of the product and the underlying safety standards valid at the time of going to print. Supplied pump will operate trouble free and satisfactorily on the condition that, it is installed with due care and maintained properly.

If operating parameters deviate from the specified parameters as on the "Nameplate", please contact manufacturer."

The manufacturer reserves the right to make technical modifications to the device or individual components. The illustrations used may differ from the original and are intended as an example representation of the device.

2 Safety

These operating instructions contain basic information which must be adhered to during installation and operation. For this reason, these operating instructions must, without fail, be read by the service technician and the responsible operator before installation and commissioning. The machine operator list must be filled out completely. By signing this list, all persons working on or with the product confirms that they have received, read, and understood this operating & maintenance manual.

It is not only the general safety instructions listed under the main point "safety" that must be adhered to but also the special safety instructions with danger symbols included under the following main points.

2.1 Designation of information in the operating instructions



Symbols:
General danger symbol



Danger due to electrical voltage



NOTE: ...

Signal words: DANGER!

Acutely dangerous situation.

Non-observance results in death or the most serious of injuries.

Warning!

The user can suffer (serious) injuries. "Warning" implies that (serious) injury to persons is probable if this information is disregarded.

CAUTION!

There is a risk of damaging the pump/installation. "Caution" implies that damage to the product is likely if the information is disregarded.

NOTE:

Useful information on using the product. It also draws attention to possible problems.

2.2 Personnel qualifications

The installation personnel must have the appropriate qualification for this work.

2.3 Danger in event of non-observance of the safety instructions

Non-observance of the safety instructions can result in risk of injury to persons and damage to product/installation. Non-observance of the safety instructions can result in the loss of any claims to damages.

In detail, non-observance can, for example, result in the following risks:

- Failure of important product/installation functions.
- Failure of required maintenance and repair procedures.
- Danger to persons from electrical, mechanical, and bacteriological influences.
- Property damage.
- WILO Mather and Platt does not accept any liability for damage, failures or losses arising due to improper installations, maintenance, repair works, modifications without our consultation and non-observance of safety instructions mentioned in this IOM.

2.4 Safety consciousness on the job

The safety instructions included in these installation and operating instructions, the existing national regulations for accident prevention together with any internal working, operating and safety regulations of the operator are to be complied with.

2.5 Safety instructions for the operator

This appliance is not intended for use by persons (including children) with reduced physical, sensory, or mental capabilities, or lack of experience and knowledge, unless they have been given supervision or instruction concerning use of the appliance by a person responsible for their safety. Children should be supervised to ensure that they do not play with the appliance.

- If hot or cold components on the product/the unit lead to hazards, local measures must be taken to guard them against touching.
- Guards protecting against touching moving components (such as the coupling) must be removed whilst the product is in operation.
- Leakages (e.g., from the shaft seals) of hazardous fluids (which are explosive, toxic, or hot) must be led away so that no danger to persons or to the environment arises. National statutory provisions are to be complied with.
- Highly flammable materials are always to be kept at a safe distance from the product.

- Danger from electrical current must be eliminated. Local directives or general directives [e.g., IEC, VDE etc.] and local power supply companies must be adhered to.
- Depending on the type, size, and capacity (kW), the products produce a sound pressure up to 75 dB (A) to 110 dB (A).
- The actual sound pressure, however, depends on several factors. These include, for example, type of prime mover, installation type; fastening of accessories and pipeline, operating site condition, background noise, etc.
- Once the product has been installed, we recommend that the operator makes additional measurements under all operating conditions.



CAUTION!

In accordance with the laws in effect, guidelines, standards and regulations, ear protection must be worn if the sound pressure is greater than 80dB (A). The operator is responsible for ensuring that this is observed!

2.6 Safety instructions for installation and maintenance work

The operator must ensure that all installation and maintenance work is carried out by authorized and qualified personnel, who are sufficiently informed from their own detailed study of the operating instructions.

Work on the product/unit must only be carried out when at a standstill. It is mandatory that the procedure described in the installation and operating instructions for shutting down the product/unit be complied with.

Immediately on conclusion of the work, all safety and protective devices must be put back in position and/or recommissioned.

2.7 Unauthorized modification and manufacture of spare parts

Unauthorized modification and manufacture of spare parts will impair the safety of the product/ personnel and will make void the manufacturer's declarations regarding safety. Modifications to the product are only permissible after consultation with the manufacturer. Original spare parts and accessories authorized by the manufacturer ensure safety. The use of other parts will absolve us of liability for consequential events.

2.8 Improper use

The operating safety of the supplied product only guaranteed for conventional use in accordance with Section 4 of the operating instructions. The limits values must on no account fall under or exceed those specified in the catalogue/data sheet.

2.9 Safety & control devices

Direct controls are applicable when the pump is supplied along with motor/panels. When motor/ panel is in end user's scope of supply, it is advised to go for CE approved motors /panels.

Environmental safety:

Disposal of any unwanted/scrap material should be disposed in appropriate way so as not to cause any harm to the environment. No hazardous material is used in WILO Mather and Platt Atmos ISO FF pumps.



NOTE:

To avoid ambiguity in the use of the word „replace“ the words „replace“ and „renew“ are used in this manual in the following context: Replace - To put back, in its existing state, a part or component that has previously been removed. Renew - To substitute a new part of component for a worn or damaged one.

3 Transport and interim storage

Immediately check the pump and transport packaging for damage in transit upon receipt. Take the necessary steps within the periods defined by the transport company in the event of damage in transit.



DANGER! Risk of getting crushed!

The installation or removal of the product must not be performed by one person alone. Measures should be taken to bar persons from standing beneath a suspended load. Furthermore, it is also prohibited to move suspended loads over exposed workplaces where people are present. The fastening devices should be adapted to the conditions at hand (weather, hooking system, load, etc.) Use suitable fastening devices to handle the weight of the product.



CAUTION! Risk of damage to the pump!

Risk of damage due to improper handling during transport and storage.

The pump should be protected against humidity, frost and mechanical damage during transport and interim storage.

3.1 Handling (Refer figure 1, Pg. No.3)



CAUTION! Risk of damage to the pump! Risk of falling!

Pumps should never be lifted with slings engaged below the bearing housing. Eyebolts on pump top casing are only for lifting top casing during maintenance. Do not lift complete pump with the eyebolts. Safe working load of wire ropes reduces with increase in included angle. Never put down or pick up the product when it is not secured. Tilting of the product should be avoided at all costs.

Only suitable lifting gear and load carrying equipment with valid test certificates and adequate lifting capacity for the loads involved (such as belts/ wire ropes/slings) should be used for lifting & transporting the product. If chains are used, they should be secured against slipping along with protective cover to prevent damage to the product, paint and/or injury to personnel.

When lifting the pump in combination with the baseplate, the lifting tackle should be attached to the lifting lugs provided on the base plate side member. To lift the pump the lifting slings should pass beneath the pump body at suction and delivery flanges. (see lifting diagrams - see also general safety Information, chapter 2 Pg. No.8) These must have sufficient load bearing capacity to ensure that the product can be transported safely.

3.2 Delivery

On arrival, the delivered items must be inspected for damage and a check made that all parts are present. If any parts are damaged or missing, the transport company or the manufacturer must be informed on the day of delivery. Any claim made later will be deemed invalid. Damage to parts must be noted on the delivery or freight documentation.

3.3 Storage

3.3.1 Short-term storage (less than 3 month)

The equipment as shipped have adequate protection for short-term storage in a covered, dry, and ventilated location at the job site prior to installation.

- If the pump is not installed immediately after delivery, it must be stored in a dry and clean place with sufficient ventilation, no vibration, no freezing, and the temperature variations must be smooth.
- Bearings and couplings must be protected against sand, dust, and foreign bodies. To avoid corrosion and jamming, please lubricate the pump and make turn the rotating elements for several turns at least once a week.
- Pre-packed desiccants may be used to absorb moisture & keep the pump dry. It must be removed before putting the pump on operation.

3.3.2 Long-term storage (more than 3 month)

If the equipment will be subject to extended storage condition prior to installation, then the manufacturer must be informed about storage duration, so that special protection can be recommended.

- Place the Atmos ISO FF pumps horizontally on firm foundation and secure it against falling.
- The machine must be protected from direct sunlight, heat, dust, and frost.
- The rotors or propellers must be turned at regular intervals. This prevents the bearing from locking.

3.4 Pump returning to the supplier.

Products, which are delivered back to the plant, must be clean and correctly packaged. In this context, clean means that impurities have been removed and decontaminated if it has been used with materials, which are hazardous to health.

The packaging must protect the product against damage.



CAUTION! Guarantee not applicable!

Products, which are not suitably packaged for delivery back, are no longer covered by guarantee!

4 Intended uses

The pump supplied is intended for specific fluid. Refer pump data sheet and order confirmation. For any change in pumped fluid refer WILO Mather and Platt beforehand. Atmos ISO FF pumps are used in water supply, water-circulating systems and process, injection water, spray pond, air-conditioning, water treatment, Sprinkler & drip irrigation, firefighting, etc. If the operating conditions are different of the specifications given in the order, (i.e., type of liquid, temperature, or duty point), the end user must ask a written agreement to WILO Mather and Platt on the new operating conditions before starting the pump.

4.1 Service Life

10 years depending on operating conditions and the fulfillment of all operating manual requirements.

5 Product information

5.1 Data plate

MODEL	<input type="text"/>	IMPELLER DIA	<input type="text"/>	mm	
SERIAL NO	<input type="text"/>	NO OF STAGES	<input type="text"/>		
CAPACITY OF PUMP	<input type="text"/>	AT (RATED NET PR)	<input type="text"/>	psi	
RATED SPEED	<input type="text"/>	rpm	MAX. NET PR.	<input type="text"/>	psi
NET PR. AT 150% RATED CAPACITY	<input type="text"/>			psi	
MAX BHP @ RATED SPEED @ ANY CAPACITY	<input type="text"/>			HP	
MAX +VE SUCTION PR.	<input type="text"/>			psi	
CENTRIFUGAL FIRE PUMP-END SUCTION					
WILO Mather and Platt Pumps Pvt. Ltd.					

Date of manufacturing is marked on the name plate.

Explanation is as follows:

MM/YY = 01/2020

MM = Month of manufacturing

YY = Year of manufacturing

5.2 Type key

Atmos_ISO FF 100-200

100 – Nominal Discharge nozzle diameter in mm.

200 – Nominal Impeller diameter in mm.

Atmos_ISO FF – Name of the Range for Firefighting.

5.3 General description

Limits of usage of the standard range for firefighting.

The technical features of the product have been described in the offer made for this product.

5.4 Scope of delivery

Pump can be delivered.

For UL certified pumps,

- Bare shaft pump with accessories.
- Pump with base plate (bare shaft pump, base plate, accessories, foundation bolts).
- Pump with base plate and motor (bare shaft pump, base plate, accessories, motor, coupling and coupling guard, foundation bolts).
- Pump with base plate and UL approved engine (bare shaft pump, base plate, accessories, UL approved engine, coupling, and coupling guard, foundation bolts.)

5.5 Accessories

For motor driven pump,

Mandatory accessories.	Recommended accessories.
Suction pressure gauge	Flow meter
Discharge pressure gauge	Spare parts
Automatic air release valve	Instruction, operation & maintenance manual.
Circulation relief valve	

For Engine driven pump,

Mandatory accessories.	Recommended accessories.
Suction pressure gauge	Flow meter
Discharge pressure gauge	Waste cone
Automatic air release valve	Diesel engine accessories
Pressure relief valve	Spare parts
	Instruction, operation & maintenance manual.

6 Description and function

6.1 Description of the product

Atmos ISO FF pumps are horizontal, single stage volute casing pumps with nominal outputs and flange dimensions meeting ANSI B16.1 CLASS 125 FF (FOR CAST IRON FLANGES) / ANSI B16.5 CLASS 150 RF (FOR STEEL FLANGES). Their back pull-out construction enables the disassembly of the complete bearing unit towards the drive side without removing the pump casing from the pipe work.

6.1.1 Shaft Seal

For Firefighting application, it is advised to use the stuffing box version with gland packing.

6.1.2 Engine driven pump

An engine driven pump set is the unitization of a bare shaft pump and a UL certified Diesel engine on the same base plate. Refer to the engine installation manual. The engine driven pump set is supplied with the foundation bolts for grounding. Use the one supplied or equivalent of bigger size. Ensure a correct electrical earth connection between engine, base plate, and main earth. (Figure 2 Pg. No.3)



NOTE:

Before starting the pump please cross check the alignment of pump and engine on the base plate, coupling bush fitment, clearness on the periphery of the coupling. If any difference in the center height is observed, please use shims of suitable thickness to overcome the misalignment.

Sr. No.	Model	IP2 (NPT)	6B1 (NPT)	8B1 (NPT)	BEARINGS FOR Atmos_ISO FF PUMP	Gland Packing Size (mmSQ)	Packing Ring length (cm)	Neck Ring & Impeller Clearances (Cl, CS, BRONZE & SS) Max.	Sleeve & Gland Clearances (mm)	Cross Sectional Drawing Reference in Annexure 1.
1	Atmos ISO FF 50-250	3/8"	1/2"	1/2"	DE - 6310 2Z / NDE - 7310 BECBP	10	102	0.219	0.5	A
2	Atmos ISO FF 65-160	1/4"	1/2"	1/2"	DE - 6306 2Z / NDE - 6306 2Z	8	72	0.219	0.435	B
3	Atmos ISO FF 65-200	3/8"	1/2"	1/2"	DE - 6310 2Z / NDE - 7310 BECBP	10	102	0.239	0.5	A
4	Atmos ISO FF 65-250	3/8"	1/2"	1/2"	DE - 6310 2Z / NDE - 7310 BECBP	10	102	0.239	0.5	A
5	Atmos ISO FF 65-315	3/8"	1/2"	1/2"	DE - 6310 2Z / NDE - 7310 BECBP	10	102	0.239	0.5	A
6	Atmos ISO FF 80-250	3/8"	1/2"	1/2"	DE - 6310 2Z / NDE - 7310 BECBP	10	102	0.255	0.5	A
7	Atmos ISO FF 100-200	3/8"	3/8"	1/2"	DE - 6310 2Z / NDE - 7310 BECBP	10	102	0.2695	0.5	A
8	Atmos ISO FF 100-250	3/8"	1/2"	1/2"	DE - 3310 2Z / NDE - 7310 BECBP	10	102	0.2695	0.5	C

1P2: Pressure Gauge; 6B1: Casing Drain; 8B1: Gland Drain; 11L: Constant level oiler; 11D: Oil Drain

6.1.3 Sealing system

To prevent leakage along the shaft at the point of emergence from the pump casing, gland packing may be fitted in the stuffing box situated at each end of the casing.

Gland Pack

For correct operation of the pack gland as light leakage (40-60 drops per minute) is essential. If the leakage is reduced too much by re-tightening the packing, the packing rings will be destroyed.

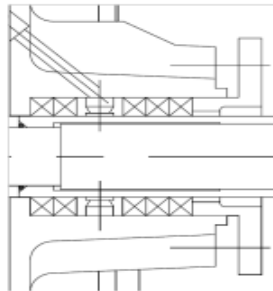

7 Installation and electrical connection (Motor / Pump coupling system)



DANGER! Risk of getting crushed!

The installation or removal of the product must not be performed by one person alone. Measures should be taken to bar persons from standing beneath a suspended load. Further more, it is also prohibited to move suspended loads over exposed workplaces where people are present. The fastening devices should be adapted to the conditions at hand (weather, hooking system, load, etc.) Use suitable fastening devices to handle the weight of the product.



WARNING! Danger of personal injury!

The installation and electrical connection should be performed only by qualified personnel in compliance with local regulations.

This section provides instructions on the recommended methods of installing pumping sets on to concrete foundations. Careful attention must be paid to the customer and contractor's installation drawings during the installation procedures to ensure that the pumping set is accurately positioned on the correct datum levels.

The existing accident prevention regulations must be observed.



WARNING! Danger of electric shock!

Any hazards from electrical current should be ruled out. Any instructions from local or general directives [e.g., IEC, VDE etc.] or directives of the local electricity supply companies must be observed.

7.1 Installation of bare shaft pump

It is strongly recommended to use component such as coupling, guards, motors, base plates supplied by WILO Mather and Platt to install a bare shaft pump on a base plate. It is mandatory that those components should be CE certified, and the coupling guard must comply with the regulation EN ISO 14120:2015.

7.1.1 Electrical motor selection

Select an electrical motor with sufficient power margin regarding the motor rating. The table below will guide you in this selection.

Shaft power	$P_2 \leq 4 \text{ kW}$	$4 \text{ kW} < P_2 \leq 10 \text{ kW}$	$10 \text{ kW} < P_2 \leq 40 \text{ kW}$	$40 \text{ kW} \leq P_2$
Recommended power margin	25 %	20 %	15 %	10 %

Example:

- Duty point: 100 m³/h – 35 m – pump efficiency 78 %
- Pump shaft power: 12.5 kW
- Electrical motor rating (including margin):
12.5 * 1.15 = 14.3 kW
- IEC motor power rating available: 15 kW
- Use a foot mounted motor B3 (IM 1001) which comply with the IEC34-1 standard.

7.1.2 Coupling selection

Use a semi-flexible coupling to link the pump to the driver. Select the size of the coupling in accordance with the recommendation of the coupling manufacturer. Strictly follow the coupling manufacturer's instructions for the fitting of the coupling between the pump and the motor. (The coupling must comply with the standard EN349).

The alignment of the pumps and the motor must be checked after the installation of the pump set on its foundation and when the piping is connected. In addition, an alignment control must take place when the system works at its nominal temperature. The coupling guard must comply with the EN ISO 14120:2015 standard to avoid any contact with rotating parts during operations.

7.1.3 Selection of a base plate

Select a base plate in accordance with the local regulations, sufficiently large and strong to support the pump and motor.

7.1.4 Pump set assembling.

Fix the pump and motor equipped with their half coupling on the base plate and make the alignment of those elements. It is recommended to fit the coupling guard supplied as accessories by WILO Mather and Platt.



Note:

If coupling guard is supplied loose, then kindly drill and fit it on the base plate at proper location.

And if pump is supplied with coupling and motor mounted on the base plate, please ensure proper alignment of pump motor and coupling.

7.2 Installation of the complete pump set

- Before any installation work is carried out, the machine should be inspected for damage that may have occurred during handling, transport & storage.
 - Installation within a building: install the pump in a dry, well ventilated, and frost-resistant room.
 - Pumping machinery should have adequate access and working room for maintenance operations. Adequate overhead space for lifting devices and working clearance must be provided.
- Installation outside a building (outdoor installation):
- Install the pump with a suitable protection to avoid rainfalls strong wind and particles which can damage the pump or motor.
 - Avoid exposure of the pump to direct sunlight.
 - An appropriate solution to avoid frost must be implemented.



CAUTION! Risk of material damage!

Ensure sufficient ventilation/heating if the ambient temperature exceeds/falls below the permitted limit values.

- Carry out all welding and soldering work prior to the installation of the pump.



CAUTION! Risk of material damage!

Dirt from the pipe system can destroy the pump during operation. Flush the pipe system prior to the installation of the pump.

- Provide shut-off valves in front of and behind the pump.

7.2.1 Foundations

The foundation should be sufficiently substantial to absorb any vibration and to form a permanent, rigid support for the base plate. The foundation must get large dimensions. Generally, the weight of the foundation is around 2 to 3 times the pump set weight. This is important in maintaining the alignment of a direct connected unit. In building the foundation, the top of the foundation should be left approximately one inch low to allow for grouting. Foundation bolts of the proper size should be embedded in the concrete, located by template (refer figure 3, Pg. No.3).

Foundation bolt

- 1 Erection packers
- 2 Finish grout
- 3 Concrete

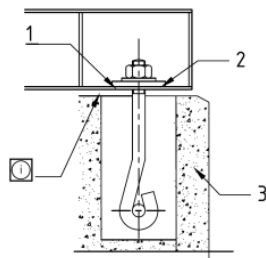

NOTE:

Leave top of foundation rough!
Do not finish with trowel.

- A pipe sleeve about 2 ½ diameters larger than the bolt should be used to allow movement for the final positioning of the bolts. For installations where a low level of noise is expected, built the foundation in a pit lined with appropriate insulation material to avoid vibration transmission to the ground.



CAUTION! Risk of material damage!

While tightening the screws/bolts, the pump as well as the motor should be free and not in coupled condition. The pump or motor should not be used as a support when tightening the screwed connections.

- It is insufficient to check level on the machined pads of base plate with a spirit level because it is possible that some types of errors will not be revealed or will be accepted as being within acceptable limits. These distortions as shown in figure 4 Pg. No.4. Therefore, it is necessary to use I-beam straight edge along with engineer's master level.

7.2.2 Leveling and installing the base plate.



CAUTION! Risk of material damage!

Pumps and drivers that are received with both machines mounted on a common base plate are checked for alignment before shipment. However, during shipment, storage it may get disturbed.

- Use I-beam straight edge and an engineer's master level (with accuracy of 0.05 mm) for leveling the base plate. I-beam should rest on the machined surfaces of the base plate, or on the leveling pads if provided. These machined surfaces where level is being checked must be clean and free from paint, burrs etc.
- Check datum position of base frame as given in G.A. Adjust the level of the base plate by inserting shims between the bed plate and the packer plate until the bed plate is leveled and supported on all the packing plates at the height required for the connection of suction and discharge branches. For checking the levels across two pads, I-beam type straight edge should be used extensively in conjunction with engineer's master level. Level should be achieved within 0.05 mm.
- When the base plate is leveled, grout the foundation bolts only. Care should be taken so as not to disturb the verticality of foundation bolts. For grouting use rich mix of 1: 1:2 of cement, sand, and gravel below 12 mm. Alternatively quick setting grout mix can be used.
- When the grout has set, gently but firmly tighten the foundation bolts. Care must be taken not to distort the base plate or loosen the foundation bolts in the grout by excessive tightening. (Figure 4, Pg. No. 4)

7.2.3 Coupling Assembly

Install the coupling avoiding hard blows; if necessary warm them for an easier fitting. Arrange the pump and motor on a level base. The shaft ends must be perfectly concentric. The distance between each half of the RB (RATHI) coupling must be 2 - 3 mm. For spacer couplings, the distance between shafts is mentioned in &10-2 – value “X” (100 / 140 / 180mm.)

If other manufacturer couplings are used, follow the manufacturer’s instructions. After installation on the foundation and connecting the pipe work, the coupling alignment must be checked and realigned, if necessary. Moreover, after reaching the operating temperature the alignment of the coupling must be checked again. The coupling requires a guard that meets DIN31001 to avoid accidental contact during operation.

In any event, the operating instructions of the coupling manufacturer must be followed, since the coupling is a component incorporated by WILO Mather & Platt.

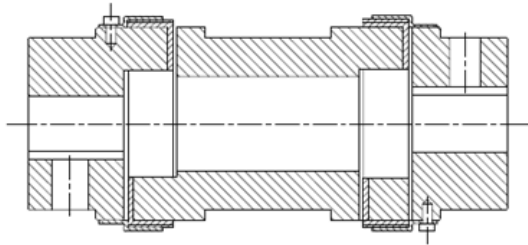

Alignment of the pumps and its driving units

- When the base plate is leveled and the satisfactory alignment is completed, proceed with connection of suction & delivery piping. Recheck the alignment after piping and run the final grout beneath the base plate. Allow minimum seven days time for curing. Grout mix in the proportion specified earlier for foundation bolt grouting should be used. It is further recommended that all hollow pockets in the base plate shall be filled after curing of earlier grout.
- The following procedures outline recommended practice given in BS-3170 in 1972 (Appendix A) for checking shaft alignment. This method is independent of the trueness of the coupling or shaft and is, therefore, not affected by canted coupling faces or eccentricity of the outside diameter of the coupling. Before commencing the alignment, rotate each shaft independently to check that the bearings run freely and that the shaft is true to 0.1mm or better. Check that no damage can be caused when the shaft of the driven unit is turned.

- Coupling should be loosely coupled, and the halves must be free to move relative to each other, Otherwise gauge Indicators can be incorrect. Where, tightly fitting pins or spring prevent loose the springs or pins should be removed and a line scribed across both half couplings and readings taken only when the two marks are aligned.

Radial Alignment

Clamp a dial gauge on one of the couplings or to the shaft as shown in figure 5 Pg. No.4 with the plunger resting on the rim of the other half coupling. Set the dial zero. Rotate the coupling and note the reading at each quarter revolution. Any variation in the readings indicates the deviation from alignment and the position of one of the units must be adjusted until the readings at each quarter revolution are identical or within the tolerances given below. Refer figure 5 Pg. No. 4.

Alignment Tolerances

Speed (rpm)	Parallel tolerance	Angular tolerance
From 1000 to 1800	0.15 mm TIR	0.10 mm TIR
From 1800 to 3600	0.10 mm TIR	0.05 mm TIR

TIR: Total Indicated reading.



CAUTION! Risk of material damage!

All the alignments (angular as well as radial) have to be carried out by using 3 dial indicators, simultaneously.

Angular alignment

After isolating the driven unit from its power supply, clamp two dial indicators at diametrically opposite points on one half coupling or to the shaft behind it with the plunger resting on the back of the other half of the coupling. Rotate the coupling unit. The gauges are to be in line vertically and set the dial to read zero. Rotate the coupling by 180° and record the readings on each gauge. The readings should be identical, though not necessarily zero. Either positive or negative readings are acceptable provided they are equally positive or negative. Adjust the position of one of the units if necessary. Rotate the coupling unit. The gauges are to be in the line horizontally and adjust the dial to zero. Repeat the operation outlined above by rotating the coupling by 180°.

7.2.4 Pipe work

No stress must be imposed on the pump casing by the pipe work; neither by the weight of the pipes nor by the tightening of badly fitting pipes (Figure 6 Pg. No.4). All pipe worked attached to the pump must be fully supported and the mating faces of the pipe flanges must be parallel and all bolt holes coinciding with each other. (See table of maximum forces on flanges) It is important, therefore, that alignment of the pump and motor should be rechecked after the pipes are finally fitted. Resetting or supporting the pipes must correct any deviation in the alignment.

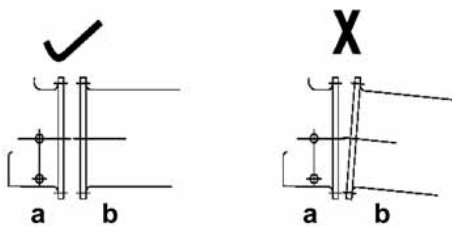

Avoid stress on the pump casing a: pump flange; b: pipe work.

For difficult pumping on the suction side, to stabilize the flow, a pipe length 1.5 times the diameter of the suction branch should be installed before the suction branch.

- The flow rate in the suction line or inflow line must not exceed 2 - 3 m/s.
- Pipe velocity may need to be reduced further to satisfy pump NPSH requirements and to control suction pipe losses.

7.2.5 Suction line

See the sketches (refer figure 7, Pg. No.5) for the optimum layout of pump installation for flow and suction lift operation. Ensure that air pockets cannot be created. Unequal nominal widths of the suction branch and suction line must be compensated by eccentric transition pieces (refer figure 8, Pg. No.5) A shut-off valve should be installed in the feed line. It must be closed for maintenance work. It should be installed in order to avoid air pockets forming in the spindle cap, i.e. with the spindle in a horizontal position or pointing vertically downward.

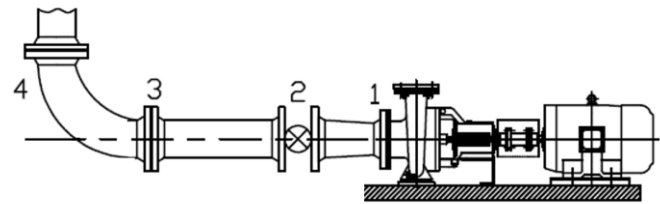

Layout of pump installation

- 1) Eccentric reducer (suction) or concentric reducer (discharge)
- 2) Isolating/Shut-off valve
- 3) Suction line
- 4) Bend
- 5) Regulating Valve
- 6) Pressure Point
- 7) Pipe Support

7.2.6 Discharge line

CAUTION! Damage to the pump

Pump casings have sometimes been cracked by pressure surges imposed on them through the absence of a non-return valve. A back flow can seriously damage the bearings and the mechanical seal.

For flow regulation, a valve must be installed behind the pump. If non-return valves are used, they should close smoothly. Pressure shocks must be avoided.

MAXIMUM ALLOWABLE FORCES & MOMENTS ON ATMOS ISO FF PUMPS, FLANGES IN CAST IRON FORCES [N] & MOMENTS [Nm].									
Flange Size [mm]		50	65	80	100	125	150	200	250
Forces (N)	Fx	710	890	1070	1420	1955	2490	3780	5340
	Fy	890	1030	1330	1780	2490	3110	4890	6670
	Fz	580	710	890	1160	1600	2050	3110	4450
Moments (Nm)	Mx	460	690	950	1330	1760	2300	3530	5020
	My	230	435	470	680	1020	1180	1760	2440
	Mz	350	530	720	1000	1360	1760	2580	3800

7.2.7 Stuffing box packing (figure 11 Pg. No. 6)

 **CAUTION! Risk of quick wear or leakages packing should be handled with care and it should not be allowed to pick up the dust or abrasive matter by coming into contact with floors or dirty benches. It is bad practice to hammer packing to facilitate the insertion.**

Pumps are dispatched from our works with the stuffing boxes unpacked; otherwise packing will be aged. The packing is packed with greaseproof paper and dispatched with the pump. The softest possible packing i.e., plaited cotton impregnated with oil and colloidal graphite is recommended for most duties. Required number of and lengths of packing should be cut off so that each length will pass once round the shaft sleeve line and meet to end. The ends of packing must be cut at 45°. After cleaning the stuffing box and shaft sleeves the packing should be inserted into the stuffing box. Each ring should be pushed into position individually using the glands joint of each ring must be positioned 180° from joints of its neighbor. A logging ring included in the arrangement; should be inserted into the stuffing box at the appropriate time during the packing sequence so that it is aligned with the cooling water connection. The gland should now be fitted square with the pump casing and the nut should be screwed up too little more than finger tightness.

7.2.9 Pressure gauge connections

 **CAUTION! Risk of leakage of the fluid!**
Never connect a pressure gauge onto the pump when the system is under pressure.

Pressure gauge connections are available on the pump casing close to the flanges. Then pressure gauge can be connected on suction and discharge side.

7.2.10 Electrical connection

 **WARNING! Danger of electric shock**
The electrical connection should be established by an electrician approved by the local electricity supply company in compliance with the applicable local regulations [e.g. VDE regulations].

- The current type and voltage of the mains connection must correspond to the specifications on the name plate.
- Refer to the motor and panels instruction manual at the time of installation and connection. Motors or electrical control panels are operated with alternating or industrial high voltage current.
- The electrical connection is established via a fixed mains connection line.
- The local regulations must be adhered to.
- Ensure that there is a provision for isolation of all energy sources and locking. If the machine has been switched off by a protective device, it must not be switched on again until the error has been corrected.

- The electrical system (machine including protective devices and operating position) must always be grounded. Refer pump GA drawing & respective manuals of motor/electrical control panel for connecting earthing suitable as per motor rating and relevant regulations and standards including proper earthing lug size and fasteners.
- Under no circumstances may any connecting cables touch the pipeline or the pump or motor housing.
- If there is a possibility that people can encounter the machine and the pumped liquid (e.g., at construction sites), the grounded connection must be additionally equipped with a fault current protection device.
- To ensure drip water protection and strain relief of the cable connections, use cables with an appropriate outer diameter and screw the cable glands tight. Furthermore, any cables nearby screwed connections for outlet loops should be bent to divert any accumulating drip water. Close any unassigned cable glands with the existing sealing discs and screw them tight.

8 Commissioning

 **WARNING! Danger of injury**

The devices whether on pump/motor/electrical panels must never be dismantled or disabled. They must be checked by an authorized technician for proper functioning before, start-up. Refer to motor & electrical panel instruction manuals for electrical safety & control devices information.

 **WARNING! Danger of pump damage!**

Do not operate the pump away from specified operating range. Operating beyond duty point may not pose a risk to the operator but will reduce the efficiency of the pump or damage the pump itself. Operation more than 5 minutes, at close valve condition is not recommended. For hot liquids this is not recommended at all. Ensure that always site NPSH-A is more than NPSH-R.

8.1 Cleaning prior to start

8.1.1 Pipe work flushing

Before the pumps are brought into service, either on initial commissioning or on re-commissioning after overhaul, the pipe work associated with the pumps must be flushed through. This will clear deposits or scales which may have accumulated in the pipes, and which could damage the internal components of the pumps.

8.2 Filling and venting

Fill and vent the system correctly, through air cock. Brief dry running will damage the pump. Please also note that these pumps are not self-priming, which means that the impeller & casing must always be fully filled with fluid to be handled before putting in operation.



WARNING! Danger of injury!

There is a risk of burns if the pump is touched! The entire pump may become very hot, depending on the operating state of the pump or system (fluid temperature).



CAUTION! Danger sealing system damage!

Any attempt to run the pump dry or partially full may result in seizure of the rotating internal components.

8.2.1 Pumps operating on flooded suction head.

When these pumps operate on a flooded open the air release valve situated on top of the pump casing, open the pump inlet isolating valve and vent the air out of the casing. When the liquid issues from the air vent, free of air, the pump is properly primed. The air vent must be closed after priming and before the pumping set is started.

8.3.2 Pre-starting checks (Refer Check List in Annexure-2)

- Check that the inlet isolating valve is open, and that the delivery valve is closed.
- Check for free rotation of the unit when coupled.
- Check that suction and delivery pressure gauges are connected. Test and make available any alarm, signals, interlock systems and any of the protective devices incorporated in the auxiliary and main pumping control system.
- Ensure that all electrical checks on motor, relay setting in panel etc. have been carried out in accordance with the instructions of motor manufacturer.
- Ensure that stuffing box sealing water seal connection is provided as shown in GA Drawing.

8.3.3 Normal starting and running checks.

- When all the foregoing pre-start checks are satisfactory, start the pump and check the direction of rotation (indicated by a direction arrow on the pump casing) otherwise stop the pump immediately for correction of direction of rotation. Then run the pump at its rated speed.
- Check the ammeter reading to ensure that the motor is not being overloaded.
- If applicable, ensure that the stuffing box is not overheating and that there is slight leakage from the gland (about 1 -2 drop per second). There may be at first a tendency for the stuffing boxes to run warm because of the high viscosity lubricant in the packing. During the first few minutes of running with new packing, a small quantity of very viscous fluid will be extruded, but the flow should reduce when the packing has settled down.
- Check that the bearing is not overheating. Bearings will normally run at a temperature of 30°C-35°C above

8.3 Starting the pump

8.3.1 Direction of rotation

Disconnect the drive coupling and run the motor to check its direction of rotation. A directional arrow is provided on the pump unit.

ambient temperature. The ideal running temperature of bearings is 40°C to 60°C for ball bearings and 40°C to 55°C for bush bearings. The temperature should never exceed 82°C for ball bearings and 75°C for bush bearings. If the bearings are overheating its cause should be investigated immediately.

- If the foregoing checks are satisfactory, open the delivery valve slowly and bring the pump gradually up to its rated parameters indicated in the data sheet/name plate and based on pressure gauge and ammeter readings. Unless the pump is fitted with a special leak-off device, it should not be run for a long period against a closed delivery valve. Check that the driving unit is not being overloaded during valve opening. Overloading may occur if the pump is discharging into an empty system. If the pumping unit fails to generate at least its rated delivery pressure it must be stopped immediately, the cause ascertained,
- Check vibration of pump set and ensure that vibration level is within limits specified. Check that noise level is within stipulated limits.
- The pumps may be run for 8 hours trial operation and all the parameters like delivery pressure, current, bearing temperature, etc. Be recorded periodically.
- Make the following checks at regular intervals. It is recommended that they be made at every change of shift.
- Check the suction and discharge pressure gauge for normal operating pressure if there is significant drop in the suction or discharge pressure the pump may have lost its supply. In the event of this fault occurring, the pump must be stopped immediately, and the cause of liquid loss eliminated.
- Check the mechanical seal or stuffing box assembly for overheating.

8.3.4 Sealing system

Gland packing



CAUTION! Risk of damaging the pump!

If the gland plate is too tight, the packing stuff will be immediately damage.

At the beginning of the operation, the leak at the gland packing should be important. It should reduce progressively after several hours by a balanced and reasonable tightening the gland plate. The gland packing must operate without excessive temperature. The correct setting of the gland packing let a permanent leak around 1 or 2 drops per seconds.

If this leak is too much and cannot be adjusted with the gland plate, the packing stuffing's are worn and must be replaced.

8.3.5 Normal shutdown



WARNING! Risk of Burns!

If the fluid temperature and system pressure is high, close the isolation valves upstream and downstream of the pump. Initially let the pump cool.

- Close the delivery valve to reduce the load on the driving unit.
- Stop the driver of the pump.
- When the pump has come to rest, close the suction-isolating valve.
- Isolate any ancillary supplies.

8.3.6 Emergency Shutdown

In the event of any malfunction of the equipment, switch off the pump set. When the pump has come to rest, close the suction & discharge valves, isolate the driving unit power supply & rectify the fault.

9 Maintenance

Maintenance and repair work should be carried out by qualified personnel only.



WARNING! Danger of electric shock!

Any danger from electrical current should be ruled out.

- The pump should be electrically isolated and secured against unauthorized switch-on prior to any maintenance or repair work.
- Any damage to the connection cable should always be rectified by a qualified electrician only.



WARNING! Risk of scalding!

At high fluid temperatures and system pressures, allow the pump to cool down first and then depressurise the system.

9.1 Routine maintenance and frequency of inspection

Centrifugal pump requires very little routine maintenance; however, serious troubles can be often avoided by regular observation and analysis of various working parameters. Some of the routine maintenance checks for this purpose are as under:

- To keep daily logbook records of working parameters like suction and discharge pressure, flow rate, current drawn, bearing temperature, etc. These parameters should be recorded twice a shift. Any sudden change should be a signal for investigation. Refer Section Maintenance & Inspection log.
- Check bearings for normal temperature. See 8.3.3 Pg. No. 20
- Vibration & sound level readings should be taken once in a fortnight and values compared with that of previous records.
- Check that there is sufficient leakage from the gland packing to ensure proper cooling and lubrication. (if applicable)
- For any abnormality observed from the visual/ manual inspection and through maintenance & inspection logs, stop the pump and investigate.
- Fault finding - Many of the common faults which occur on centrifugal pumps, and which can be diagnosed by observations are given in the chart under section 10 Faults, causes and remedies.

Routine maintenance			
Parts	Action	Period	Remarks
Gland Packing	Check for Leakage	Daily	40-60 drops/minute
	Check for Leakage	Half yearly	If required replace with new packings
Bearings	Check temperature	Weekly	If Bearing temperature exceeds 80° C, the fault. needs to be rectified.
Suction Pressure	Check Pressure	Daily	
Discharge Pressure	Check Pressure	Daily	
Flushing	Check Flow	Weekly	Flow through the Flushing pipes must be clear. and continuous
Vibration	Vibration	Weekly	Refer acceptable field vibration limit chart. Pg. No. 27
Voltage and Current	Check for the rated values	Weekly	
Rotating element	Check the rotating for wear	Yearly	
Clearances	Check the clearances between neck ring and impeller	Yearly	If value of clearance is more, neck ring should be replaced, Ref. Technical Data Pg. No. 12
Total Dynamic Head	Check Suction and Discharge TDH	Yearly	
Alignment	Check the alignment of pump. with motor	Half yearly	Refer table for alignment tolerances, Pg. No. 16



NOTE:

The above Routine Maintenance checklist is for pump only. Refer Motor / Engine manufacturers manual for the respective routine maintenance checks.

Tightening torques – Untreated Screw (black finish); Coefficient of Friction 0.14

Property Class	Torque	Nominal Diameter - Course Thread						
		M6	M8	M10	M12	M14	M16	M20
8.8	Nm	9	22	44	76	122	190	300
	Ft.lb	7	16	33	56	90	140	221

9.2 Overhaul maintenance

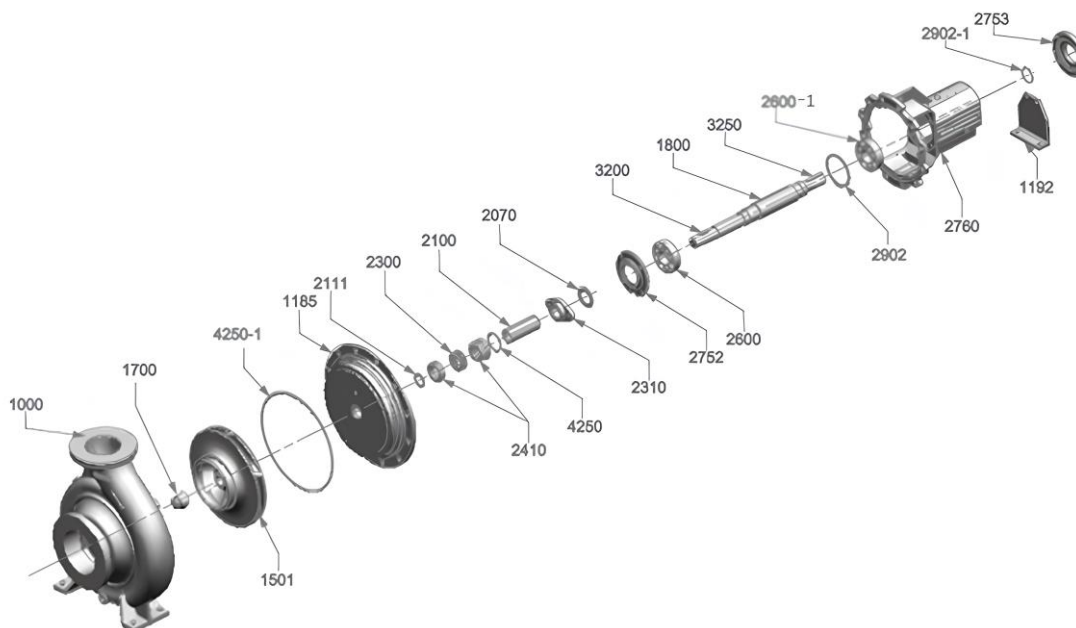

Component Overview			
No.	Description	No.	Description
1000	Casing	2600	Bearing
1185	Back cover	2752	Bearing end cover (NDE)
1192	Support foot	2753	Bearing end cover (DE)
1501	Impeller	2760	Bearing housing
1700	Impeller nut	2902	Internal circlip
1800	Shaft	2902-1	External circlip
2070	Water deflector	3200	Key (impeller)
2100	Shaft sleeve	3250	Key (coupling)
2111	Spacer sleeve	4250	O ring for sleeve
2300	Logging ring	4250-1	O ring for casing
2310	Gland	4031	Lip seal
2410	Gland packing		

9.2.1 General information

After a long period of service, wear will occur in parts of the pump, necessitating the renewal of a few components. Logbook records will indicate wear as gradual deterioration of performance is noticed. Once this is known, pumps should be taken for overhaul. It is recommended that yearly stripping & checking of wear & tear and clearances should be done and overhauling where required.

If related pair of components show a marked degree of wear in relation to the rest of the unit, then it may be sufficient to renew only the heavily worn components. If the wear is uniform throughout the pump, then all wearable components may require renewal.

Measurements should be taken and recorded of all wearable components at the first, and every subsequent overhaul period. Reference to these records will enable an accurate assessment of the rate of wear to be made, and a reasonably accurate forecast regarding when a particular component may require renewal can be made.

NOTE:

The figures given in the table (Technical Data Pg. No.12) above are only valid if the wear rings and the impeller are made with in the same materials of low galling tendencies.

9.3 Disassembling the pump.

For materials with higher galling tendencies (AISI 304/316 etc...), higher clearance is provided (0.125 mm to be added to given values).

Information regarding original design dimensions and clearances is furnished in data sheet. Any other information, if needed, can be requested from Service Department, WILO Mather and Platt. Such request must quote name plate number and type of the pump in question.

The parts most likely to be affected are:

- Impeller
- Neck Rings
- Sleeves
- Stuffing Box Bush



- Bearings
 - Coupling Bushes/ membrane set
- Before commencing dismantling operations, ensure that the following tools and tackles are available:
- A crane / chain pulley blocks suitable for handling the weight of pumping unit.
 - A selection of ring and open-ended spanners in British and

- Strip the coupling and remove the spacer if fitted.
- Unfasten nuts holding frame adaptor to pump casing (1000) and lift off rotating element with bearing housing (2760)
- Note: Where coupling without spacer is fitted, it will be necessary to move driving unit away from the pump before this operation can be carried out.
- Impeller (1501) can be drawn off after removing impeller nut (1700)
- Remove gland (2310) & back cover (1185)
- Draw shaft sleeve (2100) off the shaft (1800)

Note: Unnecessary removal of the bearings should be avoided because frequent removal of the bearings can damage it and cause deterioration of the interference fit. Bearings should be removed only if they need close inspection. Symptoms which will act as a guide are the condition of the lubricant, the bearing running temperature and the noise level during the operation.

9.4 Reassembling the pump.

- Press the drive end bearing (2600) onto the shaft (1800), pushing on inner ring.
- Fit the external circlip (2902-1)
- Vacuum and blow out all cavities of bearing housing (2760)
- Mount the bearing housing (2760) onto the shaft.
- Press the non drive end bearing on shaft.
- Fasten the outer bearing (2753) cover assembly.
- Secure the inner bearing cover (2752) assembly.
- Fit the deflector (2070) & coupling key (3250)
- Place the back cover (1185) on bench. Insert the packing (2410) / logging ring (2300) set into the stuffing box.
- Fit the gland (2310) into stuffing box.
- Hold the gland with nuts finger tight.
- Fasten the back cover assembly to frame adaptor.
- Fit the sleeve (2100) & rotate shaft (1800) check for rubbing.
- Fit the impeller key (3200) tightly, fit the gasket on front and back side of the impeller and tap Impeller lightly into place.
- Tighten the impeller nut (1700), steady the shaft at coupling end.
- Check operating gap 0.5-1.5 mm in between back cover and impeller.
- Lightly grease 'O' ring (4250) and fit.
- Stand the casing (1000) on suction flange.
- Vacuum and blow out all cavities.
- Grease the seal ring area all around
- Lower the rotating element assembly into casing take care of 'O' ring (4250-1) (Place the bearing housing in vertical position for ease of assembly)
- Fit all studs and nuts.
- Check the free rotation of shaft.
- Bolt on support foot (1192) finger tight
- Adjust the support foot and tighten bolt.
- Fit the casing plug.

Metric sizes.

- Eyebolts in Metric sizes.
- Cotton rope, wire rope and slings.
- Hardwood and metal packing blocks.
- Miscellaneous tools including a set of Allen keys, drills, pin drivers, files etc.
- Extractor / puller for bearing and coupling

9.5 Recommended spare parts.

In case of standard operation, we recommend the following list of spare part regarding the period of functioning.

It is strongly recommended to purchase the original spares parts from <WILO>. To avoid any mistake, we invite you to supply with any spare parts demand, the information mentioned on the data plate of the pump and / or motor.

- Please refer the below table for the spare part requirements.

Recommended spare parts					
Sr. No.	Description	Quantity	Recommended Spare parts		
			2 Yrs (A)	3 Yrs (B)	5 Yrs (C)
1	Bearing housing	1			
2	Back cover	1			
3	Support foot	1	✓	✓	✓
4	Gland (as applicable)	1			✓
5	Casing	1			
6	Impeller	1			✓
7	Neck ring	1	✓	✓	✓
8	Logging ring (as applicable)	1	✓	✓	✓
9	Shaft	1			✓
10	Key (coupling)	1	✓	✓	✓
11	Gland packing (as applicable)	6	✓	✓	✓
12	Key (impeller)	1	✓	✓	✓
13	Shaft sleeve	1	✓	✓	✓
14	Spacer sleeve	1	✓	✓	✓
15	Bearing end cover	2			
16	Impeller nut	1	✓	✓	✓
17	Internal circlip	1	✓	✓	✓
18	External circlip	1	✓	✓	✓
19	Bearing (impeller end)	1	✓	✓	✓
20	Lip seal	2	✓	✓	✓
21	Water deflector	2		✓	✓
22	O ring for casing	1	✓	✓	✓
23	Impeller wearing ring	1	✓	✓	✓
24	Bearing (coupling end)	1	✓	✓	✓
25	O ring for sleeve	1	✓	✓	✓

10 Faults, Causes and Remedies (For Bare Pump Only)

Symptoms	Possible cause of trouble and remedies (Each number is defined in the table below)
-- Output too low	1,2,3,4,5
-- Pump does not prime or only intermittently	6,7,8
-- Pump leaks	9,10
-- Temperature of the pump increases	7,11,13
-- Noisy pump	10,11,14,15
-- The motor contactor trips	8,10,16,17

Causes	Remedies
1 Back pressure too high	Regulate a new the operating point
2 Pump or pipe work, not filled completely.	Vent and fill the pump as well as the suction or in flow line
3 Positive suction head too low	Check the liquid level; open the shut off valves on the suction side. Clean the filters
4 Impeller sealing gap too large	Replace worn parts
5 Wrong direction of rotation	Change the motor connection
6 Pump casing, shaft seal, or suction line leaks	Replace the casing seal. Check the shaft seal. Check the flange connections
7 Positive suction head too low	Check the liquid level; open the shut off valves on the suction side. Clean the filters on the suction side
8 Loose or jammed parts in the pump	Open and clean the pump
9 Casing bolts not correctly tightened	Check the tightening torque of the casing bolts
10 Pump or pipe work not filled completely.	Vent and fill the pump as well as the suction line or in flow line
11 Pump is running against closed valve.	Open the shut off valve on discharge side.
12 Pump or pipe work not filled completely.	Purge of air the pump and the pipe work
13 Pump is not properly leveled or is distorted	Check the pump leveling and alignment
14 Foreign material in the pump	Dismantle and clean the pump
15 Earth fault	Check the earth connection. Check the potential causes such as damaged wirings or cables, leakages on electrical parts
16 Operating conditions outside of performance range of pump	Refer to pump operating conditions stated in technical data



NOTE:

The above faults, causes and remedies are for pump only. Refer Motor / Engine manufacturers manual for the respective faults, causes and remedies.

11 Decommissioning and recycling

Proper disposal and recycling of this product prevents damage to the environment and risks to personal health.

Disposal in accordance with the regulations requires the product to be drained and cleaned.

Lubricants must be collected. The pump components are to be separated according to material (metal, plastic, electronics).

1. Use public or private disposal organizations when disposing of all or part of the product.

2. For more information on proper disposal, please contact your local council or waste disposal office or the supplier from whom you obtained the product.



NOTE:

The pump must not be disposed of along with household waste!

Further information on recycling can be found at: www.wilo-recycling.com

Oil details for oil lubricated pumps (ISO Grade 46 oil)

Manufacturer	Bush Type Bearings	Grease Lubricated Bearings
Indian Oil Corporation	Servo System-46	Servogem-2/3
Hindustan Petroleum	Enclo-46	Lithion-2/3
Bharat Petroleum	Hydral-46	Multipurpose Grease-3

Hydraulic Institute Standard (ANSI/HI 9.6.4-2016)

Acceptable field vibration limit chart (9.6.4.2.5.1a)

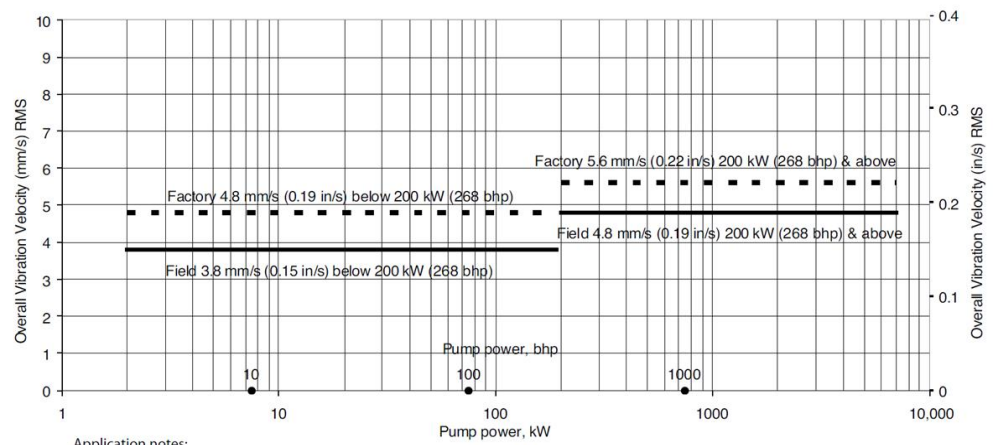
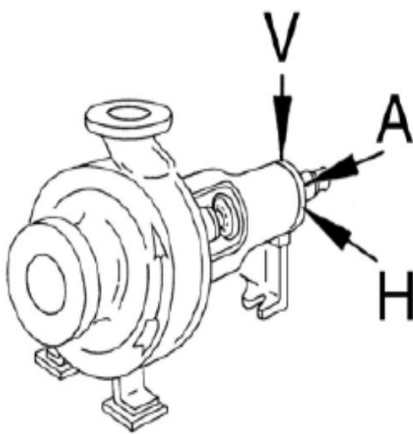

Application notes:

- 1) The factory criteria are applicable for new pumps with either a factory or new motor. The field criteria are intended for use when both the pump and motor are in new condition.
- 2) For operation outside the POR but within the allowable operating region (AOR), increase the values shown by 30%.

Annexure-1

A: Cross sectional Drawing of Atmos ISO FF with single bearing at DE and back-to-back arrangement at NDE.

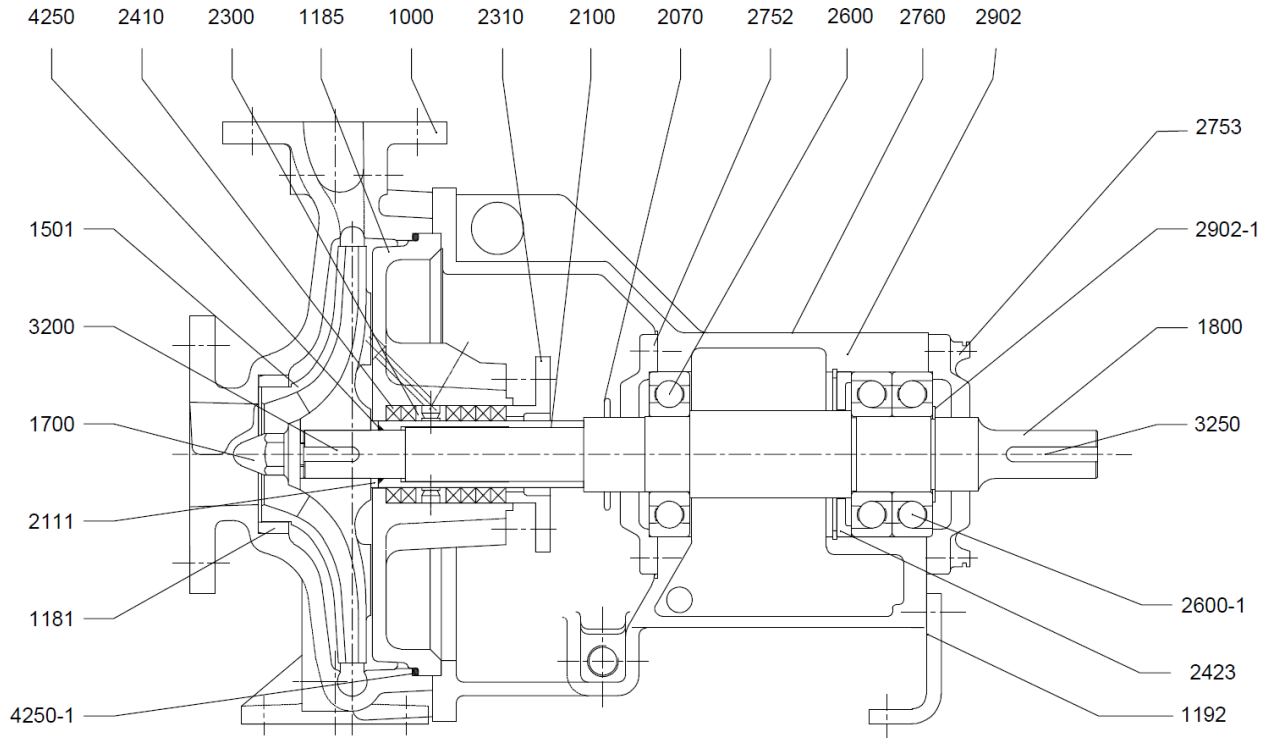

No.	Part No.	Part Name	No.	Part No.	Part Name
1	1000	Casing	16	2600-1	Bearing (NDE)
2	1181	Neck ring	17	2752	Bearing End Cover (NDE)
3	1185	Back cover	18	2753	Bearing End Cover (DE)
4	1192	Support Foot	19	2760	Bearing Housing
5	1501	Impeller	20	2902	Internal Circlip
6	1700	Impeller Nose Cap	21	2902-1	External Circlip
7	1800	Pump Shaft	22	3200	Key (Impeller)
8	2070	Water Deflector	23	3250	Key (Coupling)
9	2100	Shaft Sleeve	24	4250	'O' Ring for Sleeve
10	2111	Spacer Sleeve	25	4250-1	'O' Ring for Casing
11	2300	Logging Ring	26		
12	2310	Gland	27		
13	2410	Gland Packing	28		
14	2423	Retainer Plate	29		
15	2600	Bearing (DE)	30		

B: Cross sectional Drawing of Atmos ISO FF with single bearing at DE and single bearing at NDE.

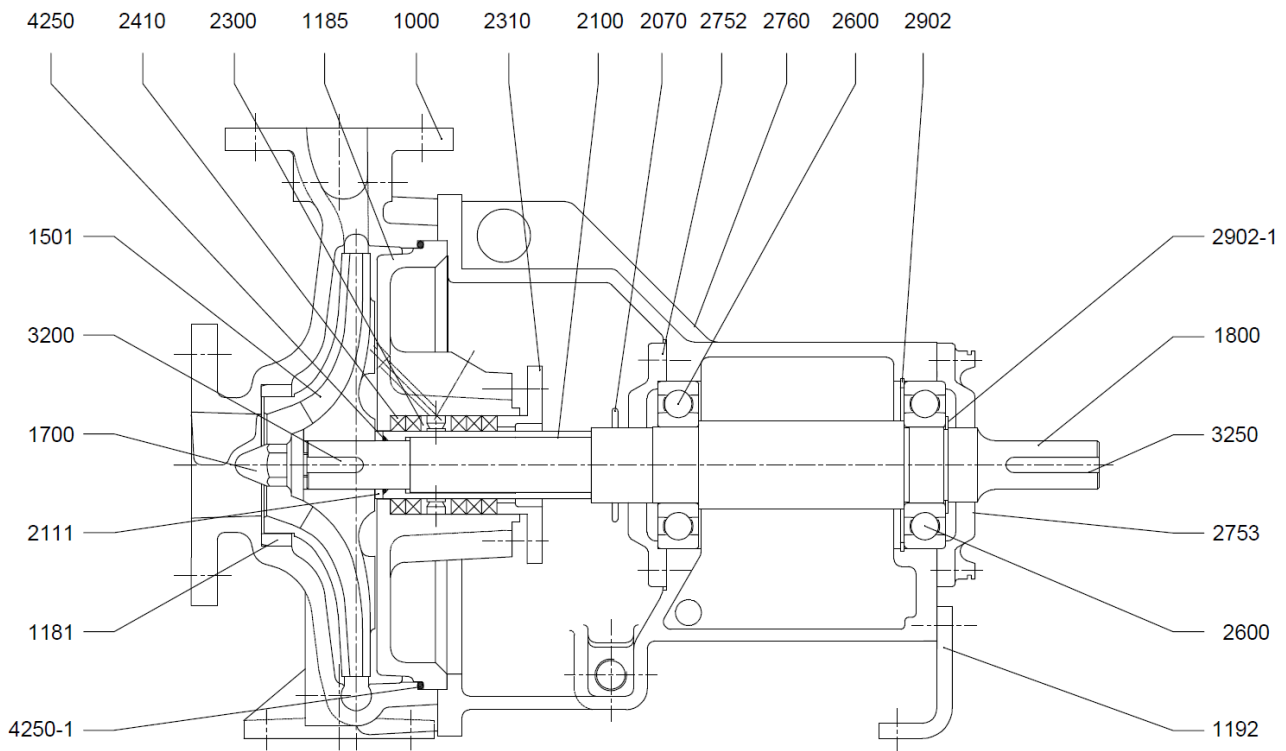

No.	Part No.	Part Name	No.	Part No.	Part Name
1	1000	Casing	16	2600-1	Bearing (NDE)
2	1181	Neck ring	17	2752	Bearing End Cover (NDE)
3	1185	Back cover	18	2753	Bearing End Cover (DE)
4	1192	Support Foot	19	2760	Bearing Housing
5	1501	Impeller	20	2902	Internal Circlip
6	1700	Impeller Nose Cap	21	2902-1	External Circlip
7	1800	Pump Shaft	22	3200	Key (Impeller)
8	2070	Water Deflector	23	3250	Key (Coupling)
9	2100	Shaft Sleeve	24	4250	'O' Ring for Sleeve
10	2111	Spacer Sleeve	25	4250-1	'O' Ring for Casing
11	2300	Logging Ring	26		
12	2310	Gland	27		
13	2410	Gland Packing	28		
14	2423	Retainer Plate	29		
15	2600	Bearing (DE)	30		

C: Cross sectional Drawing of Atmos ISO FF with back-to-back arrangement at DE and back-to-back arrangement at NDE.

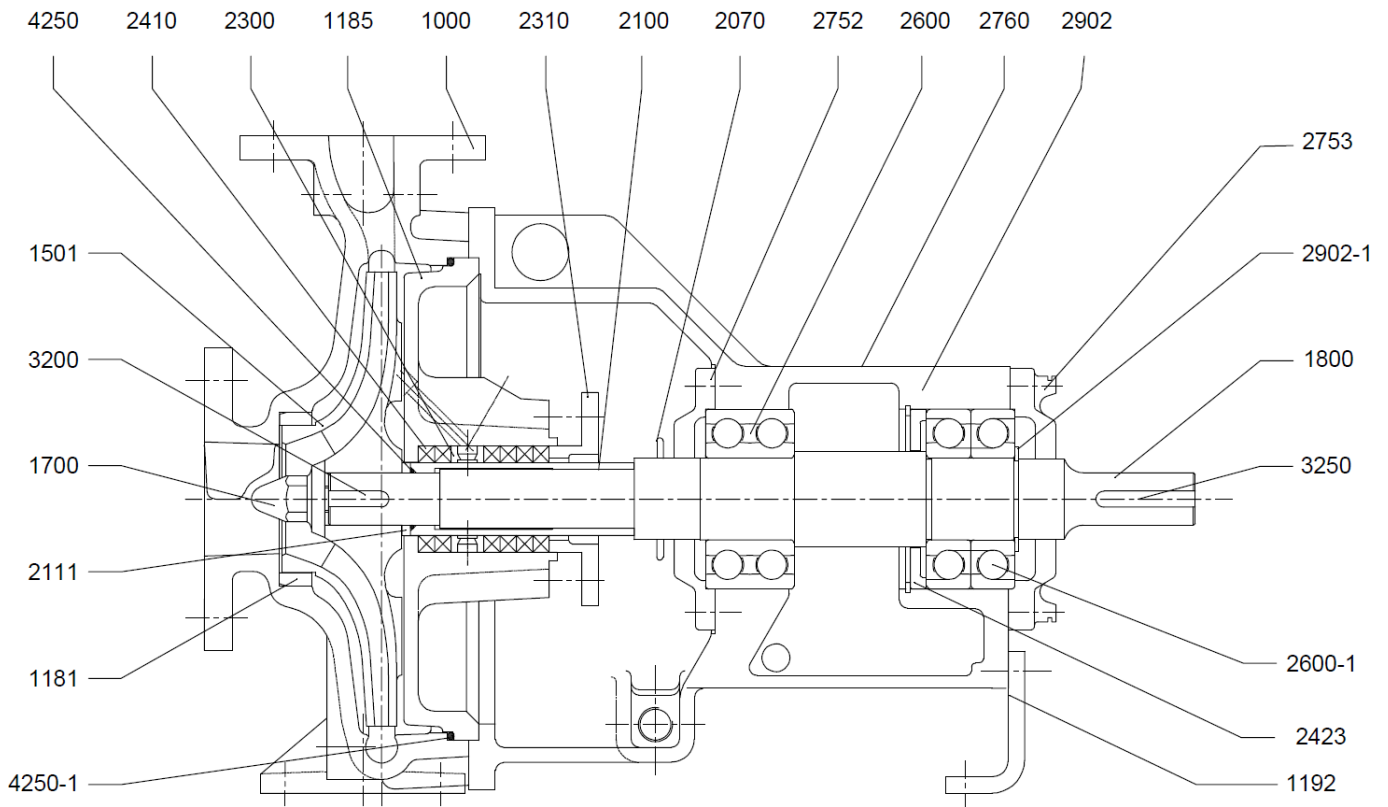

No.	Part No.	Part Name	No.	Part No.	Part Name
1	1000	Casing	16	2600-1	Bearing (NDE)
2	1181	Neck ring	17	2752	Bearing End Cover (NDE)
3	1185	Back cover	18	2753	Bearing End Cover (DE)
4	1192	Support Foot	19	2760	Bearing Housing
5	1501	Impeller	20	2902	Internal Circlip
6	1700	Impeller Nose Cap	21	2902-1	External Circlip
7	1800	Pump Shaft	22	3200	Key (Impeller)
8	2070	Water Deflector	23	3250	Key (Coupling)
9	2100	Shaft Sleeve	24	4250	'O' Ring for Sleeve
10	2111	Spacer Sleeve	25	4250-1	'O' Ring for Casing
11	2300	Logging Ring	26		
12	2310	Gland	27		
13	2410	Gland Packing	28		
14	2423	Retainer Plate	29		
15	2600	Bearing (DE)	30		

Annexure-2

Pre-commissioning checklist Pump with Motor			
Sr. No.	Activities	Checked on	Remarks
1	Levelling of Pump set		
2	Alignment with and without piping		
3	Flushing of pipelines and ensures no leakages		
4	Availability of sufficient liquid in sump/suction as per specifications		
5	Installation of all instruments		
	Suction and delivery pressure gauges		
	Pressure switches		
	Temperature gauges		
	Any other as supplied/specified		
6	Operation of suction, delivery, and inline valves		
7	Proper supports for piping and other allied equipment		
8	Availability of flushing/sealing liquid for stuffing box		
9	Availability of sufficient cooling liquid for bearings as specified		
10	Free rotation of pump and drive shafts		
11	Lubrication of bearings		
12	Checking of insulation resistance of motor (if supplied by WILO M&P)		
13	Proper cable termination (Clients Scope)		
14	Motor Protection Relay Setting (Check with Clients)		
15	Check all interlocks as specified/provided		
16	No load trial operation of drive		
	Direction of rotation is ok		
	Noise and vibration are within limits		
	Bearing temperatures and winding temperatures are within limits		
	Overall operation is satisfactory		
17	Coupling of pump and drive and free rotation of shafts in coupled condition		
18	Suction valve is fully opened		
19	Pump is fully primed, and all air is vented		
20	Delivery valve is closed (if required)		
21	Emergency shutdown is possible		

Pre-commissioning checklist Pump with Engine



Sr. No.	Activities	Checked on	Remarks
1	Levelling of Pump set		
2	Alignment with and without piping		
3	Flushing of pipelines and ensures no leakages		
4	Availability of sufficient liquid in sump/suction as per specifications		
5	Installation of all instruments		
	Suction and delivery pressure gauges		
	Pressure switches		
	Temperature gauges		
	Any other as supplied/specified		
6	Operation of suction, delivery, and inline valves		
7	Proper supports for piping and other allied equipment		
8	Engine is installed properly on foundation with AVM pads		
9	In case of HE cooled engine, all external water connections are done		
10	Availability of flushing/sealing liquid for stuffing box		
11	Availability of sufficient cooling liquid for bearings as specified		
12	Free rotation of pump and drive shafts		
13	Batteries are fully charged		
14	Battery cables and lead are available		
15	Exhaust silencer and all required exhaust piping is completed		
16	Fuel tank is supplied. Supply & return fuel lines connected to engine		
17	Engine coupled with water pump and all discharge piping is completed		
18	Lube oil, coolant and fuel is available at site		
19	Lubrication of bearings		
20	Checking of insulation resistance of motor (if supplied by WILO M&P)		
21	Proper cable termination (Clients Scope)		
22	Motor Protection Relay Setting (Check with Clients)		
22	Check all interlocks as specified/provided		
23	No load trial operation of drive		
	Direction of rotation is ok		
	Noise and vibration are within limits		
	Bearing temperatures and winding temperatures are within limits		
	Overall operation is satisfactory		
24	Coupling of pump and drive and free rotation of shafts in coupled condition		
25	Suction valve is fully opened		
26	Pump is fully primed, and all air is vented		
27	Delivery valve is closed (if required)		
28	Emergency shutdown is possible		

Pump Commissioning Report (Motor Driven Pumps)



Customer: _____ **Service Ref.:** _____

Sr. No.: _____ **Date:** _____

Details of Pump		Details of Motor	
Pump Sr. No.		Motor Make	
Type of Pump		Sr. No.	
Head		Frame Size	
Capacity		Kw / Hp.	
RPM		RPM	
Construction		Voltage	
		Current	

Details of System		Piping Details	
Application		Suction Pipe Size	
Liquid		Delivery Pipe Size	
pH Value		Valves	
Suction	Flooded / Lift	Expansion Joints	

Pump Operating Parameters		Motor Operating Parameters	
Suction Pressure		Current	
Discharge Pressure		Voltage	
RPM		RPM	
DE Bearing Temperature		DE Bearing Temperature	
NDE Bearing Temperature		NDE Bearing Temperature	
Duration of Trial Run		Winding Temperature (Max.)	

Observations and Remarks:

Customer Representative _____ **WILO M&P Representative** _____

Pump Commissioning Report (Engine Driven Pumps)



Customer: _____ **Service Ref.:** _____

Sr. No.: _____ **Date:** _____

Details of Pump		Details of Engine	
Pump Sr. No.		Engine Make	
Type of Pump		Sr. No.	
Head		Type / Model	
Capacity		BHP	
RPM		RPM	
Construction		Cooling System	

Details of System		Piping Details	
Application		Suction Pipe Size	
Liquid		Delivery Pipe Size	
pH Value		Valves	
Suction	Flooded / Lift	Expansion Joints	

Pump Operating Parameters		Engine Operating Parameters	
Suction Pressure		RPM	
Discharge Pressure		Oil Pressure	
RPM		Water Temperature	
DE Bearing Temperature		Lubricating Oil Temperature	
NDE Bearing Temperature		Gear Box Temperature	
Duration of Trial Run			

Observations and Remarks:

Auto Mode / Manual Mode

Customer Representative _____ **WILO M&P Representative** _____

Required accuracy of pump set levelling is 0.05 mm

A) BEDPLATE

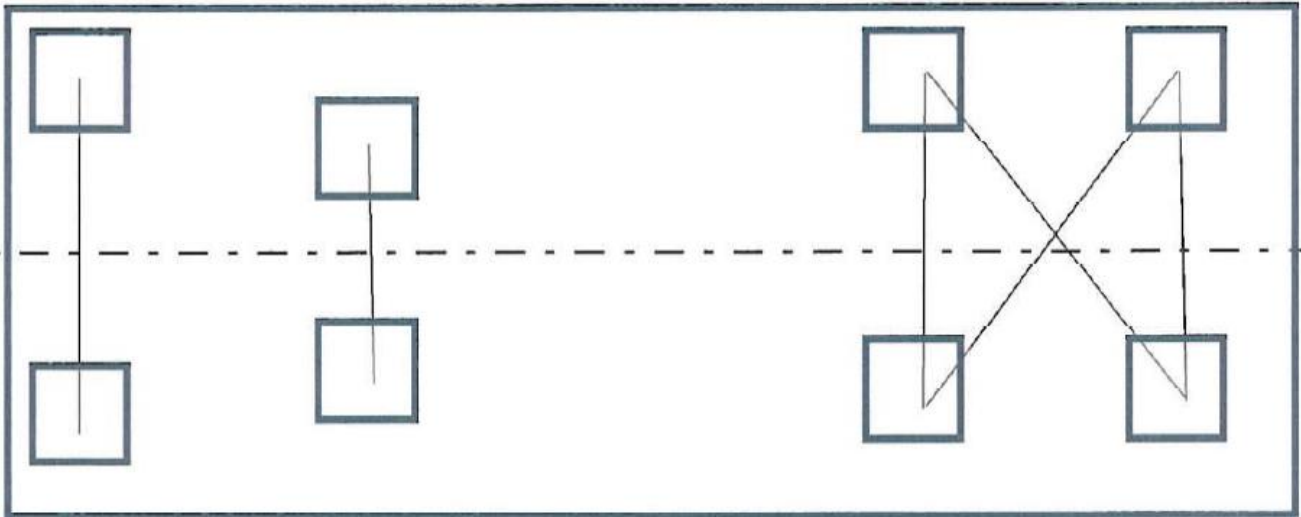

SOLEPLATE:-

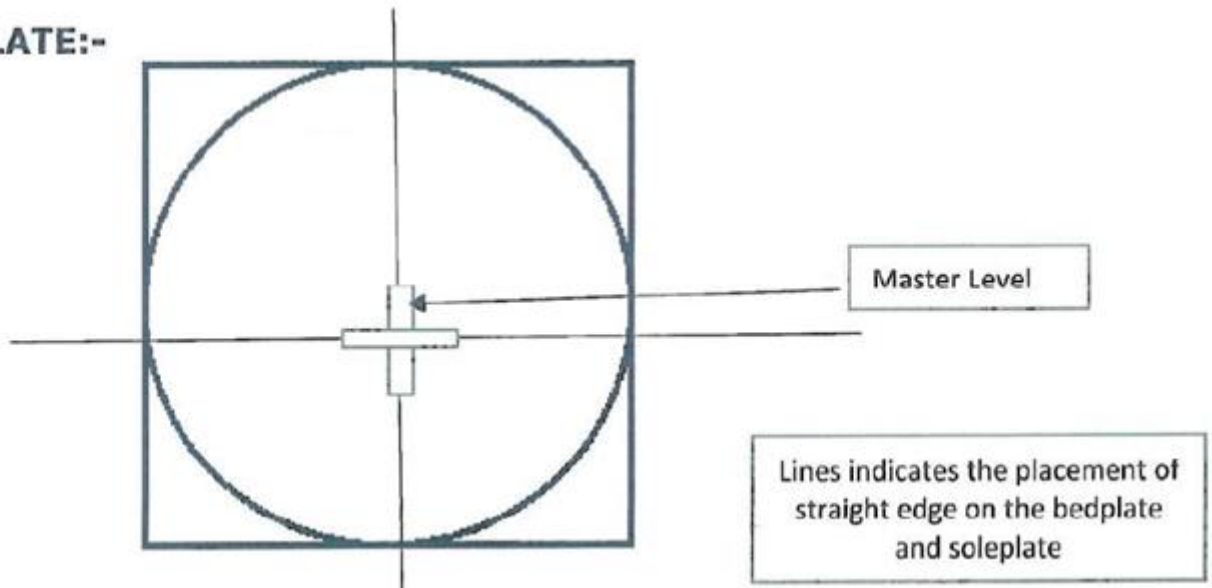

Result:

Customer Representative

WILO M&P Representative

A: Before Connecting Suction and Delivery Piping:

RADIAL



AXIAL



Gap Between Coupling Halves: _____ mm

Actual Gap: _____ mm

B: After Connecting Suction and Delivery Piping:

RADIAL



AXIAL



Gap Between Coupling Halves: _____ mm

Actual Gap: _____ mm

Customer Representative

WILO M&P Representative

Noise level measurement at Pump House Floor

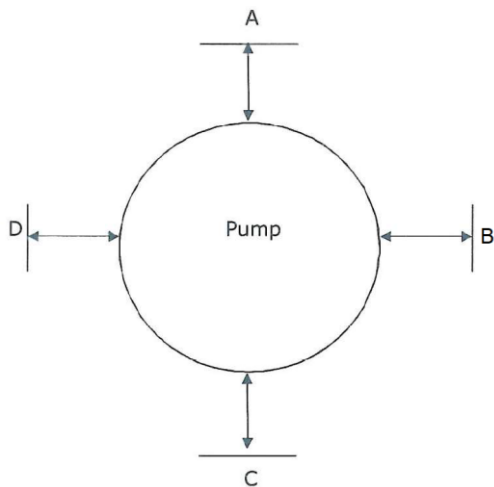

Noise Level in dBA:

A:	B:
C:	D:

Background Noise (dBA):
Instrument Details:
Distance -1 Mtr. from the Pump:
Make:
Model:
Sr. No.:

Customer Representative

WILO M&P Representative

Pump set Vibration Measurement



Pump Set Details:

Date:

Pump Sr. No.	Motor Sr. No.:
Pump Type:	Make:
Project:	

Vibration Measurement: (Pk to Pk)

Sr. No.	Position	V		H		A	
		Displacement	Velocity (mm/sec.)	Displacement	Velocity (mm/sec.)	Displacement	Velocity (mm/sec.)
1	Pump DE						
2	Pump NDE						
3	Motor DE						
4	Motor NDE						

Instrument Details:

Make:
Model:
Sr. No:

Customer Representative

WILO M&P Representative

Pump set Bearing Temperature Measurement



Pump Set Details:

Date:

Pump Sr. No.	Motor Sr. No.:
Pump Type:	Make:
Project:	

Bearing Temperature:

Sr. No.	Position	Temperature	Ambient Temperature	Remarks
1	Pump DE			
2	Pump NDE			
3	Motor DE			
4	Motor NDE			

Instrument Details:

Make:
Model:
Sr. No:

Customer Representative

WILO M&P Representative

WILO Mather and Platt Pumps Pvt. Ltd.

Mumbai-Pune Road, Chinchwad,

Pune- 411 019, Maharashtra (India)

Tel: +91 20 27442100/1/2/3/4,

Toll Free Service: 1-800-266-8866

Fax: +91 2027442111

service.in@wilo.com

www.wilo.in