

MOTOR DIMENSIONS NEMA TCV FRAME 2900 RPM TEFC

| HP | PHASE | FRAME | L | AB | O | H |
|-----|-------|--------|-------|-------|------|------|
| 5.0 | 3 | TCV215 | 16.16 | 10.24 | 7.46 | 6.23 |
| 7.5 | 3 | TCV215 | 16.16 | 10.34 | 7.38 | 6.23 |
| 10 | 3 | TCV215 | 17.19 | 10.34 | 7.38 | 6.23 |

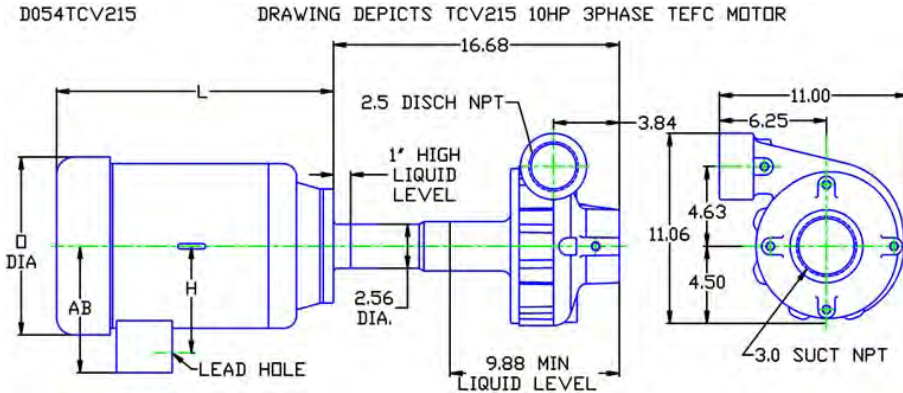

ALL DIMENSIONS IN INCHES.

DRAWING REPRESENTS APPROXIMATE PUMP DIMENSIONS. AUTOCAD DRAWING TO SCALE AVAILABLE FROM FACTORY.

OPTIONAL MOUNTING PLATE MP11

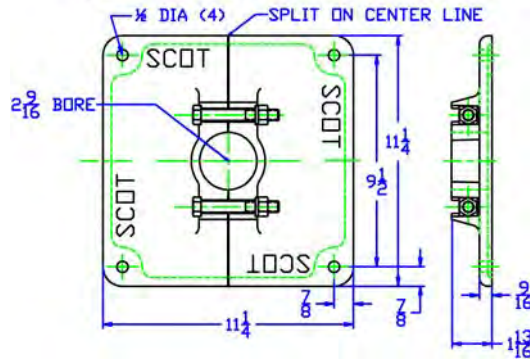

D1040 D054TCV215
05410VWE 0542900

54
TCV
VWE 54
0542900TCV
81.001.552 M19

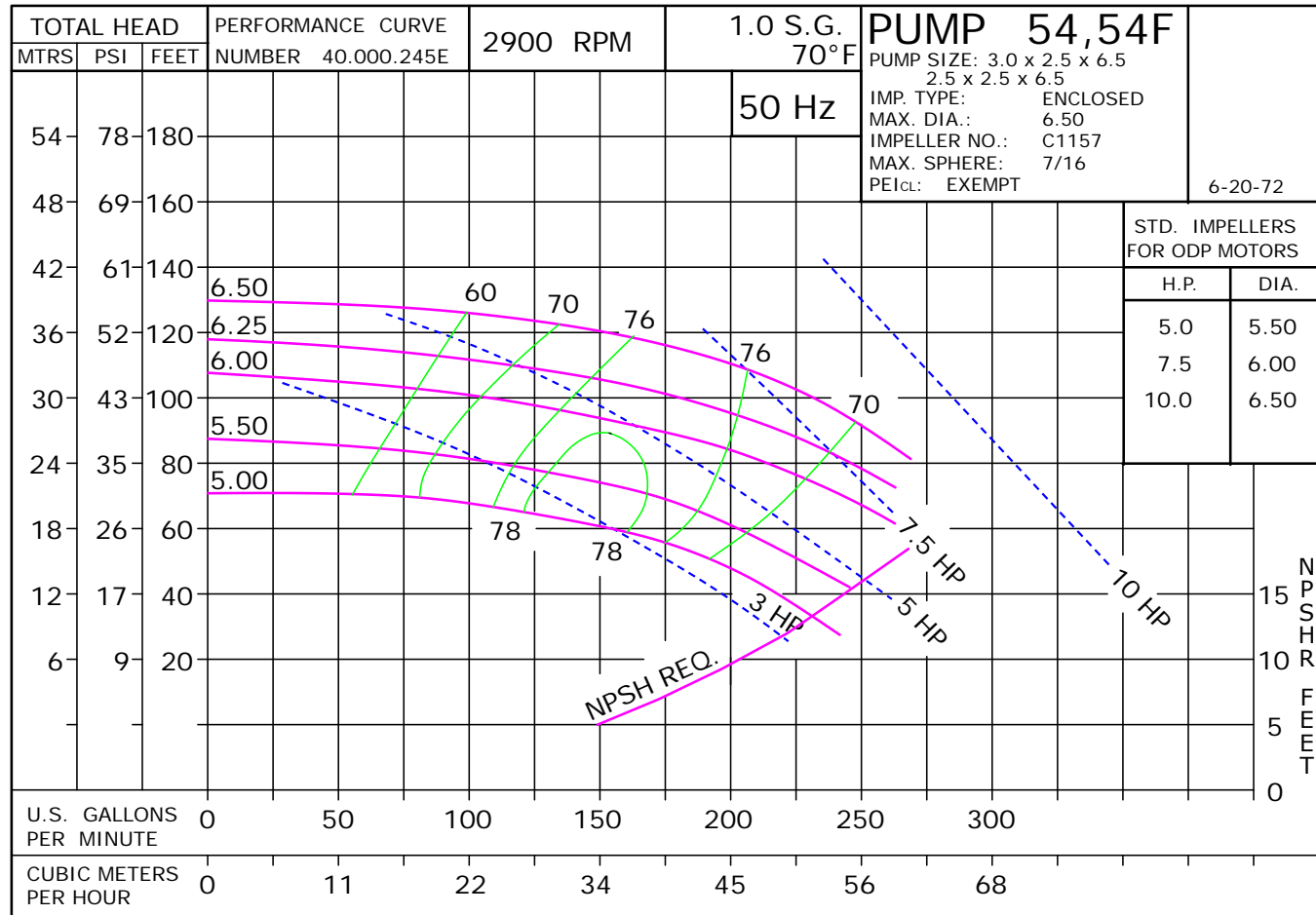

50 Hertz Pump & Motor Data

A 3-phase 50 Hertz Motorpump™ can be obtained in several ways. The most common options are listed below:

1. Most 60 Hz pumps available from Scot Pump can be operated on a 3-phase 50 Hz 190/380V power. However, when operated on 50 Hz power, the speed is reduced by approximately 20%, and a significant reduction in performance is realized. The charts below indicate these reductions in performance.
2. Pumps will produce the performance indicated in the performance curves when operated on 50 Hz power. The motors for these selections can be obtained through *derated 60 Hz motors* and *wound 50 Hz motors*.

Contact factory for 1 Phase applications.

Derated 60 Hz Motors

The most common practice and readily available method of obtaining a 50 Hz motor is by using the next larger 60 Hz motor and derating it to the desired horsepower on 50 Hz. Many High Efficient motors can be operated on 50 HZ power without a reduction in horsepower. The motor manufacturers 60 HZ nameplate will remain intact. An "Alternate Motor Rating" nameplate indicating the reduced horsepower, RPM, volts, amps, and service factor will be affixed to the pump. In utilizing this practice, service factors may be derated to 1.0. The standard voltage is 190/380V and has a ±10% voltage variation. In addition, 200/400V and 208/416V may be available. Please contact the factory for approval of the rating for your specific application.

Wound 50 Hz Motors

Specially wound 50 Hz 220/380V six-lead Delta Wye motors are available. Most ratings offer a ±15% voltage variation. These motors are not normally a stock item and require an extended lead time.

The impeller and horsepower combination sized (taking the reduction in speed into consideration) may not be suitable for operation on 60 Hz power. The increase in speed, performance and load may overload the system and the electric motors. **Pumps sized for 50 Hz operation SHOULD NOT be tested on 60 Hz.**

| 60 Hz Pump on 50 Hz Power | | |
|---------------------------|--------|--------|
| No Impeller Change | | |
| 50 Hz | 60 Hz | Factor |
| GPM = | GPM x | 0.829 |
| Head = | Head x | 0.687 |
| BHP = | HP x | 0.569 |

| To Size 60 Hz Pump Using 50 Hz Data, | | |
|--------------------------------------|--------|--|
| Obtain 60 Hz Data As Follows: | | |
| 60 Hz | 50 Hz | Factor |
| GPM = | GPM x | 1.2 |
| Head = | Head x | 1.45 |
| BHP = | HP = | $\frac{\text{GPM} \times \text{Head} \times \text{SG of}}{3960 \times \text{Eff}}$ |

| Change of Speed (RPM) | | |
|-----------------------|-------------|---|
| | How Varies: | Examples |
| GPM | Directly | Double RPM = (2)(RPM) = (2)(GPM) Triple RPM = (3)(RPM) = (3)(GPM) |
| Head | Square | Double RPM = (2)(RPM) = (2) ² = (2)(2) = (4)(Head) Triple RPM = (3)(RPM) = (3) ² = (3)(3) = (9)(Head) |
| BHP | Cube | Double RPM = (2)(RPM) = (2) ³ = (2)(2)(2) = (8)(BHP) Triple RPM = (3)(RPM) = (3) ³ = (3)(3)(3) = (27)(BHP) |

| Change of Impeller Diameter (Dia.) | | |
|------------------------------------|-------------|---|
| | How Varies: | Examples |
| GPM | Directly | Double Dia. = (2)(Dia.) = (2)(GPM) Triple Dia. = (3)(Dia.) = (3)(RPM) |
| Head | Square | Double Dia. = (2)(Dia.) = (2) ² = (2)(2) = (4)(Head) Triple Dia. = (3)(Dia.) = (3) ² = (3)(3) = (9)(Head) |
| BHP | Cube | Double Dia. = (2)(Dia.) = (2) ³ = (2)(2)(2) = (8)(BHP) Triple Dia. = (3)(Dia.) = (3) ³ = (3)(3)(3) = (27)(BHP) |

VWE 54 • Iron • TCV Frame • 2900 RPM

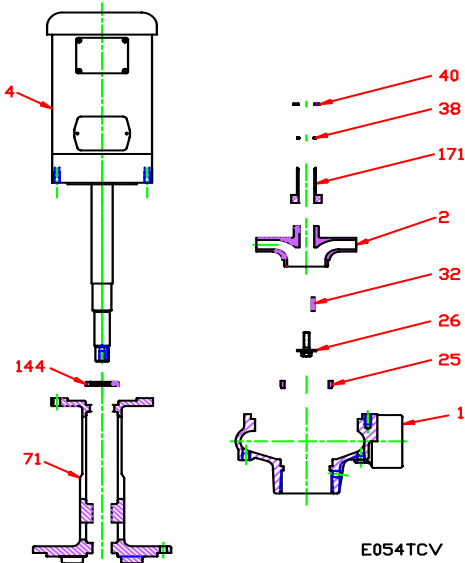

E054TCV

| KEY NO. | PART NAME | SPEC SERIES‡ | |
|---|--|-------------------|-----------------------|
| | | 3190 OLD STYLE | 3435 PRESENT STYLE |
| 1+ | CASE, IRON, 3 x 2.5 NPT | 130.000.249X1 | |
| 2 | IMPELLER, 7/8" KEYED ENCLOSED, SPECIFY DIAMETER: IRON | 131.000.812 | |
| 4 | MOTOR, TCV140 | See 60HZ Chart | |
| 25 | WEAR RING, STEEL | 103.000.153 | |
| 26* | IMPELLER RETAINER, STAINLESS | † 118.000.163A | |
| 32* | KEY, STAINLESS | † 102.000.102 | |
| 38* | O-RING, SHAFT, VITON | -- | † 116.000.105 |
| 40* | FLINGER, STAINLESS | -- | † 104.000.165A |
| 71 | ADAPTER, IRON | 132.000.291 | † 132.000.291B |
| 144* | LIP SEAL, BUNA | † 101.000.244 | |
| 171* | THROTTLE BUSHING, STEEL | 110.000.348 | † 110.000.348C |
| -- | REPAIR KIT | 118.000.546 | 118.000.628 |
| -- | RETROFIT KIT CONVERTS OLD STYLE TO PRESENT | -- | 118.000.625 |
| | MOUNTING PLATE MP11: (not shown) | 118.000.329 | |
| | MOUNTING PLATE (2 REQ'D) | 132.000.292 | |
| | CAP SCREW (2 REQ'D) | 105.000.457 | |
| | WASHER (2 REQ'D) | 137.000.697 | |
| | NUT (2 REQ'D) | 105.000.122 | |
| * DENOTES COMPONENTS INCLUDED IN REPAIR KIT. + INCLUDES STEEL WEAR RING. † DENOTES ITEMS INCLUDED IN RETROFIT KIT. ‡ SPEC SERIES 3190 WAS MANUFACTURED FROM 1984 THROUGH 01/13/04. SPEC SERIES 3435 IS THE CURRENT CONSTRUCTION AS OF 01/14/04. | | | |

E054TCV

VWE 54 • Iron • TCV Frame • 2900 RPM

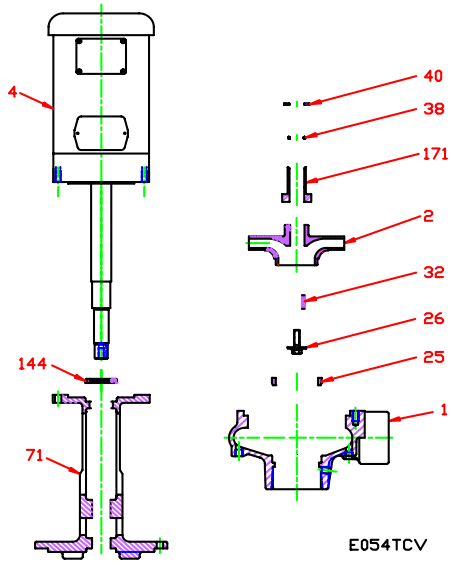

| CONSTRUCTION OPTIONS | | |
|----------------------|----------------------------------|-----------|
| KEY NO. | PART NAME | CAST IRON |
| 1 | Case | Iron |
| 2 | Impeller | Iron |
| 25 | Wear Ring | Steel |
| 26 | Impeller Retainer Assembly | Stainless |
| 32 | Key | Stainless |
| 38 | O-ring, Shaft | Viton |
| 40 | Flinger | Stainless |
| 71 | Adapter | Iron |
| 144 | Lip Seal | BUNA |
| 171 | Throttle Bushing | Steel |
| NS | Mounting Plate MP11: (not shown) | Iron |

E054TCV
E15

C0542900TCV