

FDH

Fabricated Steel Discharge Head

PLAD FDH fabricated steel discharge heads are designed to provide a larger window for easier access to the headshaft coupling and product lubricated stuffing box.

This heavy-duty fabricated steel discharge head features a high pressure stuffing box with bronze bearing. The standard design includes a by-pass line for proper lubrication and cooling of the stuffing box.

Capacity to 3,000 GPM

Pressure to 275 PSI

Horse Power to 250 HP

Setting to 100 Feet

PLAD FDH fabricated steel discharge heads have twice the tensile strength of similar cast iron models, allowing the FDH to exceed cast iron pressure ratings.

The extended discharge head configuration provides:

- A larger working area.
- A higher discharge connection.
- An air separation chamber.
- Enough space to install an air release valve directly on top of the discharge head.

Drive Shaft:	1¼", 1½" (Optional)
Discharge Flange:	6", 8" (std.), 10", 12", and 14"
Flanged Column:	6", 8" (std.), 10", 12", and 14"

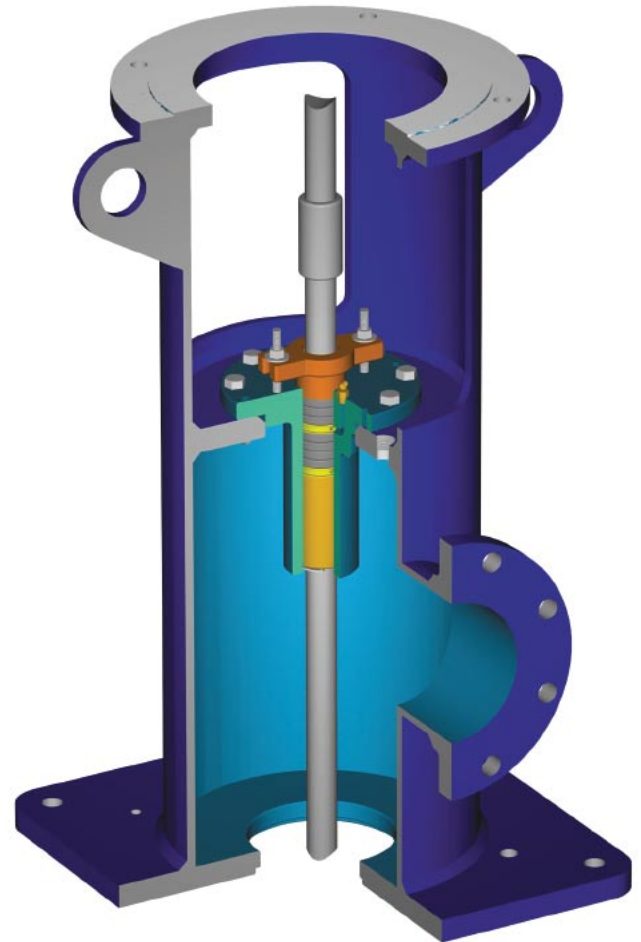

PLAD FDH Standard Features

- Product Lubricated High-Pressure Stuffing Box.
- NEMA Type "P" Fit Drivers (BD=16½").
- 150 # ANSI Flanged Discharge Connection.
- Flanged Column Connection.
- 1 in. Thick Square Steel Sole Plate.
- Ductile Iron Stuffing Box and Bronze Packing Gland.
- Lifting Lugs.
- Integral Air Separation Chamber.
- Sand Blasted to a Near White Metal (SSPC-SP6).
- Urethane Enamel Paint Over an Industrial Epoxy Primer.

Fabricated Steel Discharge Head

Suggested Product Specifications

The vertical turbine pump discharge head shall be fabricated of carbon steel featuring a minimum of 60,000 psi tensile strength and shall be capable of withstanding a working pressure of 275 psi.

The discharge flange shall be a 150 # ANSI flat face flange per ANSI B16.5.

The column connection under the discharge head shall be fabricated to receive a specially machined 150 # flange that features a precise center guide raised face.

The discharge head shall accept a NEMA Type "P" standard base, vertical hollow shaft motor with a BD of 16½".

The discharge head shall be designed to allow air to be discharged through an air release valve mounted directly on top of the head.

A product lubricated high pressure stuffing box containing two lantern rings and six rings of 100% graphite packing shall be provided.

Such packing shall be compressed around the drive shaft by an adjustable bronze packing gland.

A by-pass line shall release water from the first lantern ring for proper cooling and packing lubrication. The discharge head stuffing box area shall include a drain which will be piped, by the contractor, underneath the discharge head sole plate.

The discharge head shall be sand or grit-blasted to a near white metal condition under SSPC-SP-6 requirements and shall immediately thereafter be painted with an industrial epoxy primer (1-GP-165) to a thickness of 5 to 6 mils, in order to receive a final coat of urethane enamel paint, for a total minimum thickness of 10 to 12 mils.

An optional ductile iron bearing retainer with neoprene bearing installed between the flange column connection and the discharge head is also available.

The fabricated steel discharge head shall be model FDH-____ as manufactured by Plad Equipment Ltd.

Discharge Head Friction Loss Graph

Discharge Head Friction Losses

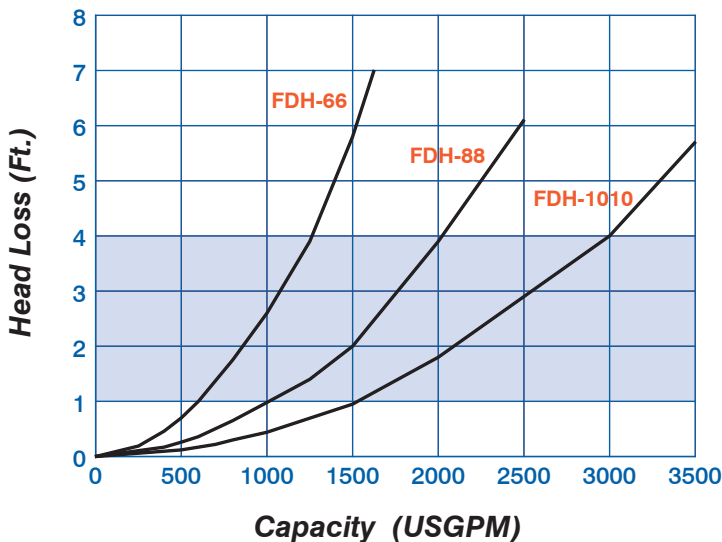

Note: Shaded areas indicate recommended flow range.



Fabricated Steel Discharge Head

Dimensions

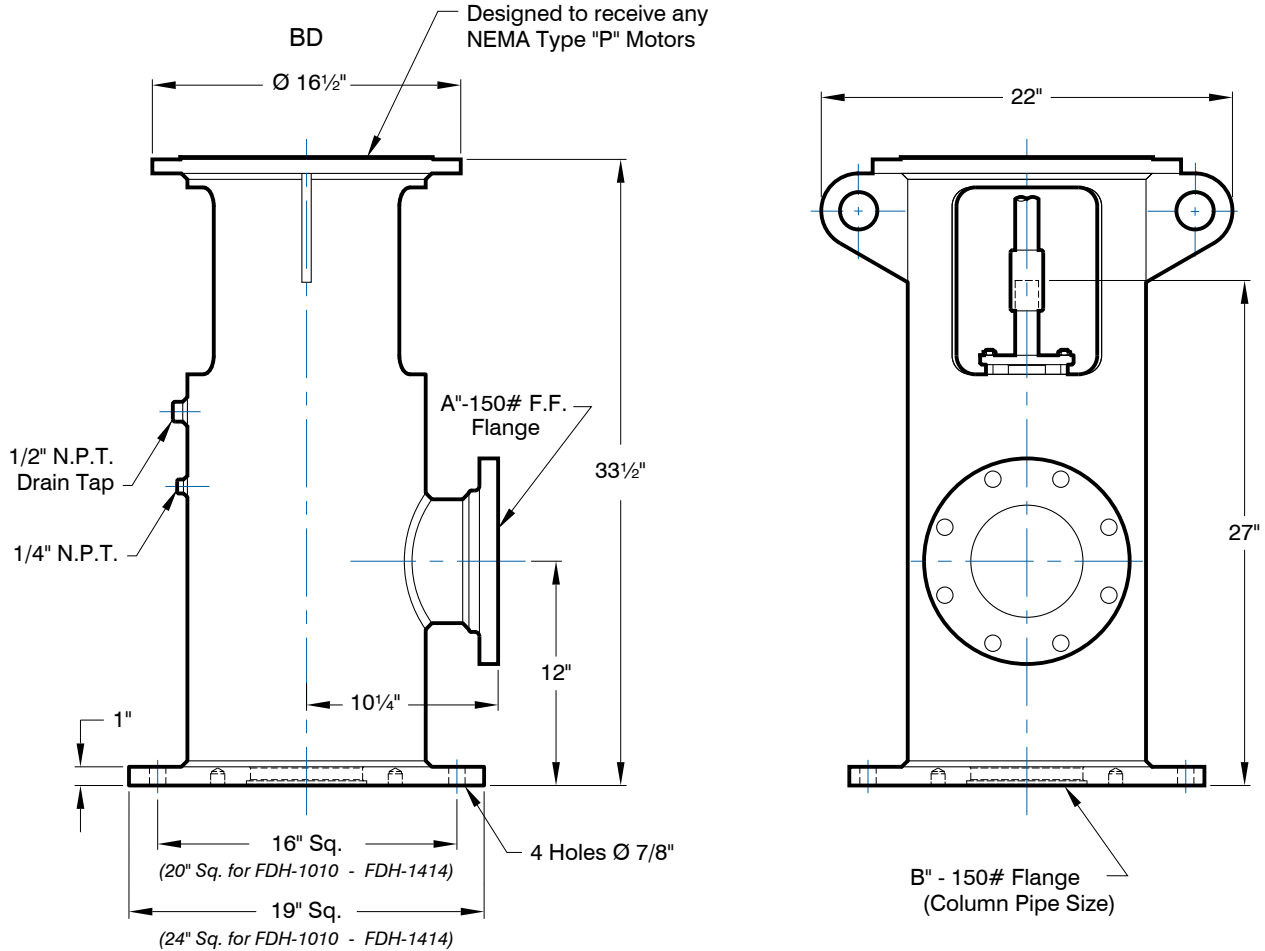

Model Number	Flange Discharge A - Size (150 #)	Flange Column B - Connection	Maximum BD Driver	Max. Head Shaft Diam.	Weight (Pounds)
FDH-66 *	6"	6"	16½"	1¼"	350
FDH-68 *	6"	8"	16½"	1¼"	375
FDH-88	8"	8"	16½"	1½"	400
FDH-1010	10"	10"	16½"	1½"	425
FDH-1214	12"	12"	16½"	1¼"	474
FDH-1414	14"	14"	16½"	1¼"	500

* Standard Model in Stock.

Note: 1¼" Shaft diameter is standard, 1½" is an optional feature.

FDH-66 & FDH-88 in Stock!

All **PLAD FDH** discharge heads are custom fabricated and can be built to your exact specifications, within an 8 to 12 weeks delivery schedule, except for the **FDH-66** and **FDH-88** models that Plad keep in stock for standard applications.

PLAD FDH is VFD rated!

The **FDH** head is particularly suited for VFD applications. Its elongated shape makes the structure more flexible, keeping natural frequencies low and out of the operating range. Because the discharge head is steel fabricated, critical speeds can be accurately determined and avoided.

Fabricated Steel Discharge Head

PLAD FDH Optional Features

There are several optional features available on the **PLAD FDH** fabricated discharge head. These features shall be identified by suffixes added to the discharge head model number.

Example: **FDH-66AS**

- A = Air release valve assembly
- S = Spider bearing retainer under head

Suffix	Description
A	Air release valve assembly mounted on top of discharge head.
B	12" BD motor adaptor plate.
C	Turbine in a can configuration.
D	Packing gland drain line.
E	Reduced discharge flange adaptor 6" x 5" - 150 # ANSI for FDH-66.
F	Reduced discharge flange adaptor 6" x 4" - 150 # ANSI for FDH-66.
L	Sole plate leveling bolts.
S	Spider bearing retainer assembly in between discharge head and flanged column pipe.
3	300 # ANSI discharge flange.

Contact Plad Factory for any Special Material or Other Feature Requirements.

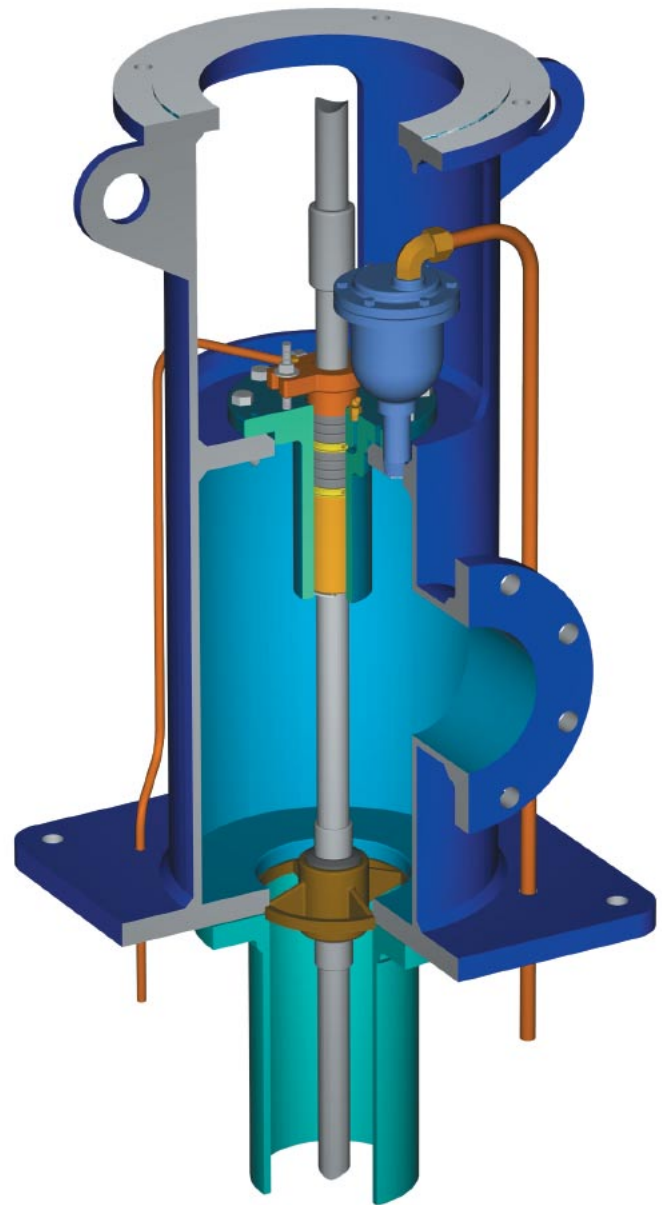

FDH-66AS

The above figure illustrates the **FDH-66AS** fabricated steel discharge head with the optional air release valve assembly and optional spider bearing retainer installed on the underside. This reduces vibration and drive shaft deflection, providing longer life at the stuffing box level.

General Material Specifications

Description	Material	Grade
Discharge Head	Steel	ASTM A36-90
Stuffing Box	Ductile Iron	ASTM A536-84
Stuffing Box Bearing	Bronze	ASTM B505
Packing Gland	Bronze	ASTM B505
Lantern Rings	Bronze	ASTM B505
Stuffing Box O'Ring	Elastomer	Buna N
Snap Ring	Steel	Zinc Plated
Studs and Nuts	Steel	Zinc Plated
Packing Rings	Graphite	Teflon Reinforced

Web Site: **www.plad.com**

E-mail: **plad@plad.com**

