

Inspection

Check pump for shortage and damage immediately upon arrival. Note damage or shortage on freight bill (bill of lading); immediately file claim with carrier.

EXTERIOR — Pay particular attention to conduit box, external hardware, and accessories. Touch up abrasions or scratches with approved paint.

INTERNAL — If extensive or serious external damage is noted, if impeller is damaged (look in ports), or if shaft binds or sticks, disassemble as required to permit internal inspection.

Handling

Handle with care. Dropping or jarring can seriously damage motor bearings or break pump parts. Lift with device having capacity for pump weight, and use lifting hooks or eye bolts (if provided) or rig double sling around motor frame and pump casing. Do not use sling through pump motor adapter nor around suction or discharge flanges.

Installation

Location — Pump location should provide the following:

1. Install as close to suction supply as possible.
2. Shortest and most direct suction pipe practical. Suction lift must not exceed limit for pump. NPSH available must equal or exceed pump requirement.
3. Suction port below pumping level to provide priming.
4. Room for inspection and maintenance.
5. Correct power supply to motor; all wiring should meet National Electrical and Local Codes and Regulations.
6. If outdoors, protection from the elements, freezing and water damage due to flooding.

Piping — Suction and discharge gauges are useful to check pump operation and are excellent trouble indicators. Install gauges in the lines if pump ports do not have gauge taps. Observe these precautions when installing piping:

1. Support close to, but independently of pump.
2. Use the next larger pipe size for suction and discharge.

3. Keep as straight as possible. Avoid bends and fittings.
4. Remove burrs and sharp edges, ream pipe cuts, and make joints air-tight.
5. Don't spring pipe to make connections. Strain must not be transmitted to pump.
6. Allow for pipe expansion with hot fluids; expansion joints are not recommended.

Suction — Size and install suction piping to keep pressure loss at minimum and to provide correct NPSH by observing the following:

1. The suction pipe should be equal in size to or preferably one size larger than the suction connection of the pump. If pipe is larger than the pump suction, an eccentric pipe reducer should be used at the pump.
2. Pipe should slope upward to pump, even for horizontal run.
3. Use 45-degree or long-sweep 90-degree elbows.
4. A valve in the suction is necessary only on positive suction head installation and must not be used to throttle the pump. The suction valve should be installed for maintenance purposes only.

Discharge — Pumps permit discharge port location at any of four positions, 90 degrees apart. Change by removing cover bolts, rotating casing, and replacing bolts. Do not slice O-ring. Scot does not recommend bottom vertical discharge due to erratic pump performance. Ensure there is adequate clearance with selected position between wall or tank, motor conduit box, and grease fittings. Casing may extend beyond base or feet.

1. Short discharge lines may be the same size as the discharge port. Long runs require a pipe larger than the discharge port.
2. Long horizontal runs require a grade as even as possible. Avoid high spots and loops. Trapped air will throttle flow and may result in erratic pumping.
3. Install check and gate valves in discharge line; check valve (if used) between pump and gate valve.

Operation

Pre-Start — Before initial start of the pump, check as follows:

1. The rotation must be checked upon installation. Close, then break the contacts quickly and observe the rotation of the exposed portion of the rotating parts. Rotation must agree with the rotation arrow on the motor. For all pumps, the standard rotation is counterclockwise when viewed from the suction end. Motor wiring is easily changed in the field. Observe the wiring diagram on the inside of the terminal box cover, or on the motor nameplate.
2. Check voltage, phase and frequency of line circuit with motor nameplate.
3. Check suction and discharge piping and pressure gauges for proper operation.
4. Assure that the pump is full of liquid (primed).

Priming — If pump is installed with a positive head on the suction, prime by opening suction valve and allowing liquid to enter the casing, at the same time venting all air out of the top of the casing. If pump is installed with a suction lift, priming must be done by other methods, such as foot valves, ejectors, or by manually filling casing and suction line.

CAUTION - DO NOT RUN PUMP DRY. Serious damage may result if started dry.

Starting — Proceed as follows to start pump:

1. Close drain valves and valve in discharge line.
2. Fully open all valves in the suction line.
3. Prime the pump. If pump does not prime properly, or loses prime during start-up, shut down and correct condition before repeating procedure.
4. For pumps moving high temperature liquids, open warm-up valve to circulate liquid for preheating. Close valve after pump has warmed up.
5. Start the motor (pump).
6. When pump is operating at full speed, open discharge valve slowly.

Running — Periodically inspect pump while running, but especially after first start and following repair.

1. Check pump and piping for leaks. Repair immediately.

2. Record pressure gauge readings for future reference.
3. Record voltage, amperage per phase, and kW (if an indicating wattmeter is available).
4. Adjust pump output capacity with discharge valve. DO NOT throttle suction line.

Freezing Protection — Protect pumps shut down during freezing conditions by one of the following methods:

1. Drain pump; remove all liquid from the casing.
2. Keep fluid moving in pump and insulate or heat the pump to prevent freezing. If heated, do not let temperature go above 100 to 150 degrees F.
3. Fill pump completely with antifreeze solution.

Maintenance

Cleaning — Remove oil, dust, dirt, water, and chemicals from exterior of motor and pump. Keep motor air inlet and outlet open. Blow out interior of open motor with clean compressed air at low pressure. Regularly drain moisture from TEFC motors.

Temperature — Total temperature, not the rise, is the measure of safe operation for a motor. If temperature by thermometer exceeds limits for insulation class, investigate and change operating conditions.

Labeled Motors — It is imperative for repair of a motor with Underwriters' Laboratories label that original clearances be held; that all plugs, screws, other hardware be fastened securely, and that parts replacements be exact duplicates or approved equals. Violation of any of the above invalidates Underwriters' label.

Lubrication — Pumps should require no maintenance, other than the motor bearings, according to the following instructions:

DOUBLE SHIELDED. When double shielded prelubricated bearings are furnished, no lubrication is required for the life of the bearings. Inspect bearings periodically to determine the condition of the grease and replace the bearings if necessary.

SINGLE SHIELDED W/GREASE FITTING PROVISIONS. When single shield bearings are furnished, periodic inspection, cleaning and relubrication is required. See motor manufacturer's specific instructions for lubrication.

Mechanical Seal Replacement

A.) Disassembly:

1. Turn off power.
2. Close suction and discharge valves.
3. Drain pump.
4. Remove bolts holding base to foundation
5. Remove casing bolts.
6. Remove motor and rotating element from casing, leaving casing and piping undisturbed.
7. Hold the impeller from rotation using strap wrench and remove impeller retaining assembly with socket wrench (Figure 1).

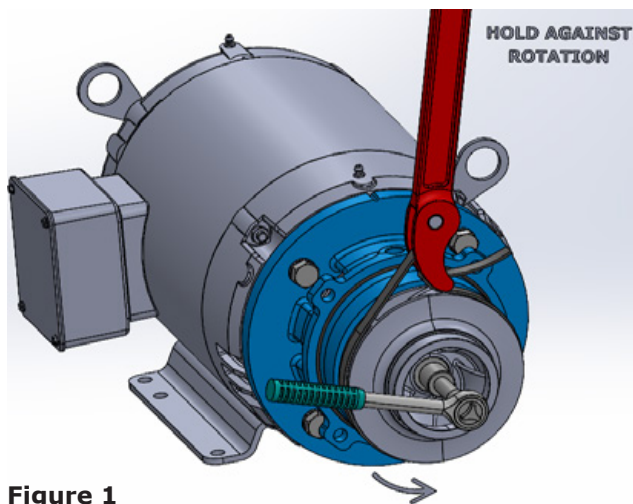

Figure 1

8. Remove impeller from shaft, being careful not to lose the impeller key, spring, and seal retainer. If impeller is difficult to remove, it may be necessary to use a bearing puller to pull off impeller.
9. Pry the rotating member of the seal away from the motor by inserting two screwdrivers 180 degrees apart under the flinger and prying evenly until flinger hits the adapter (Figure 2).

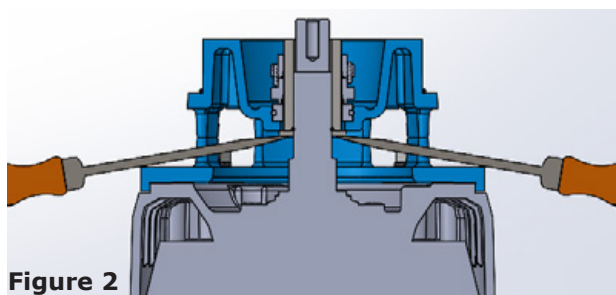

Figure 2

10. Pry the rotating member of the seal the rest of the way off the motor shaft using two screwdrivers 180 degrees apart under the seal face (Figure 3).

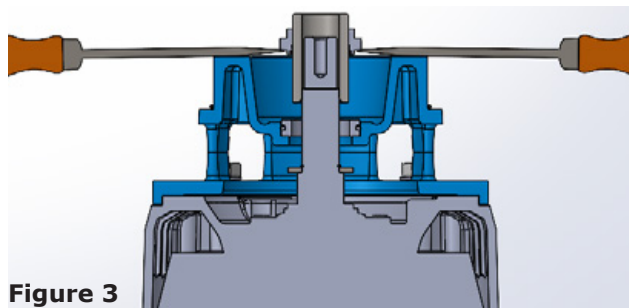

Figure 3

11. Remove bolts holding adapter to motor. Lightly tap adapter away from motor using rawhide or plastic-tipped hammer until two screwdrivers can fit 180 degrees apart between adapter and motor. Using even pressure, pry adapter away from motor until shaft sleeve is free.
Note: This step is not required if shaft sleeve slides freely on motor shaft.
12. Place adapter on a flat surface with case rabbet facing down, and push out stationary part of mechanical seal.
13. Inspect the shaft sleeve, shaft O-ring, and flinger. If damaged or worn, remove and replace with a new one.

B.) Reassembly:

CAUTION: The mechanical seal is a precision product and should be handled accordingly. Use care when handling the lapped running surfaces of the mechanical seal to ensure they remain clean and free of chips or scratches.

1. Clean o-ring and flange faces, seal seat cavity, shaft sleeve, and motor shaft.
2. Position the stationary seat with the silver dot down (away from you) and the lapped face (shiny side) facing you. Lubricate the seal seat cavity of the adapter and the rubber cup or O-ring of stationary seal seat with the lubricating fluid that comes with the mechanical seal or repair kit. Press the stationary seat in seal seat cavity of the adapter squarely and evenly using an arbor press (if possible) and the cardboard disc supplied with the seal. Be certain that the lapped face (shiny side) is facing you.
3. Install the flinger on the motor shaft until it bottoms on the motor shaft.
4. Slide the shaft O-ring on the motor shaft until it is tight against the flinger. Make sure that the shaft O-ring does not get damaged during this procedure.

Reassembly, cont...

5. Position shaft sleeve chamfer towards motor and slide on motor shaft.
6. With motor preferably in vertical position, remount the adapter on motor, making sure the motor shaft does not dislocate or chip the stationary seat of the seal.
7. Apply the lubricating fluid that comes with the mechanical seal or repair kit to the shaft sleeve and the rubber bellows of the rotary seal. Slide the seal head on the sleeve; press the rubber drive band on the rotary head until the lapped face on the head seats firmly against the lapped face of the stationary seat. Do not chip or scratch faces during installation. Take extra care to make sure the lapped faces are clean. Install spring on seal head and retainer on spring.
8. Place key in key seat. Line up keyway in impeller with key on the motor shaft and slide impeller on motor shaft. Be certain that the key is positioned in the keyway of the motor and impeller. Slightly compress seal spring with impeller and hold impeller while installing impeller retaining assembly in motor shaft.
9. Hold the impeller from rotation using strap wrench and tighten the retaining assembly as discussed in paragraph 7 of disassembly instructions. The impeller will compress the seal spring to the proper length assuring correct pressure on lapped faces.
10. Slide motor and rotating element in casing. Be sure that any damaged O-ring is replaced.
11. Tighten casing bolts alternately and evenly.
12. Replace hold-down bolts.
13. Check for free rotation after assembly is completed.
14. Seal all drain openings using pipe sealant on threads.
15. Reprime before starting. Do not start until pump is completely filled with water.

The approved lubricating fluid for seal installation is included with the mechanical seal or repair kit.
DO NOT USE OTHER LUBRICATING LIQUIDS!

WE RECOMMEND STOCKING A SPARE MECHANICAL SEAL OR REPAIR KIT TO ELIMINATE DOWN TIME.

**Pressure and Temperature Limitation
 Standard Fitted Pumps**

Pump No.	Pressure		Temperature	
	Standard	Optional	Standard	Optional
701	175 PSI	175 PSI	220°F	275 °F
702	175 PSI	175 PSI	220°F	275 °F
704	175 PSI	175 PSI	220°F	275 °F

CAUTION

DO NOT ALLOW EITHER THE DISCHARGE PRESSURE OR THE TEMPERATURE OF THE LIQUID TO EXCEED THE LIMITATIONS LISTED ABOVE.