

MOTOR DIMENSIONS NEMA JM FRAME 3 PHASE ODP

HP	TYPE	FRAME	D	E	F	O	AB	BG	L	MH
5.0	ODP	JM182	4.50	3.75	2.25	8.56	6.70	5.75	5.46	.41
7.5	ODP	JM184	4.50	3.75	2.75	8.56	6.70	6.25	5.75	.41
10	ODP	JM213	5.25	4.25	2.75	10.41	7.97	7.03	6.21	.41
5.0	TEFC	JM184	4.50	3.75	2.75	8.85	7.57	5.51	7.64	.41
7.5	TEFC	JM184	4.50	3.75	2.75	8.85	7.57	5.51	7.64	.41
10	TEFC	JM215	5.25	4.25	3.50	10.37	8.19	6.77	9.16	.41

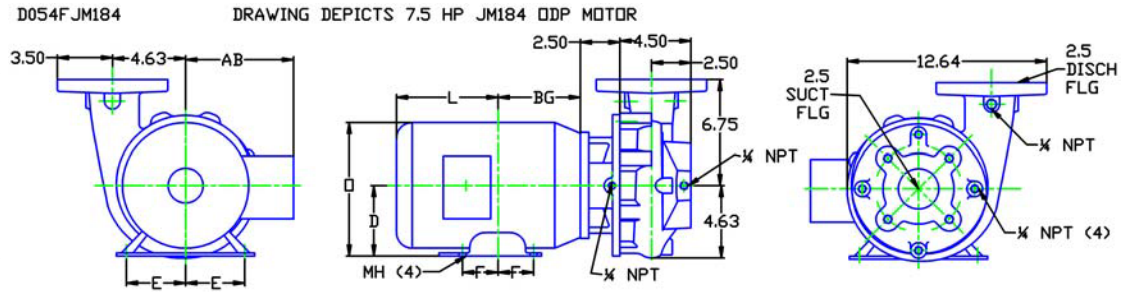

ALL DIMENSIONS IN INCHES.

DRAWING REPRESENTS APPROXIMATE PUMP DIMENSIONS. AUTOCAD DRAWING TO SCALE AVAILABLE FROM FACTORY.

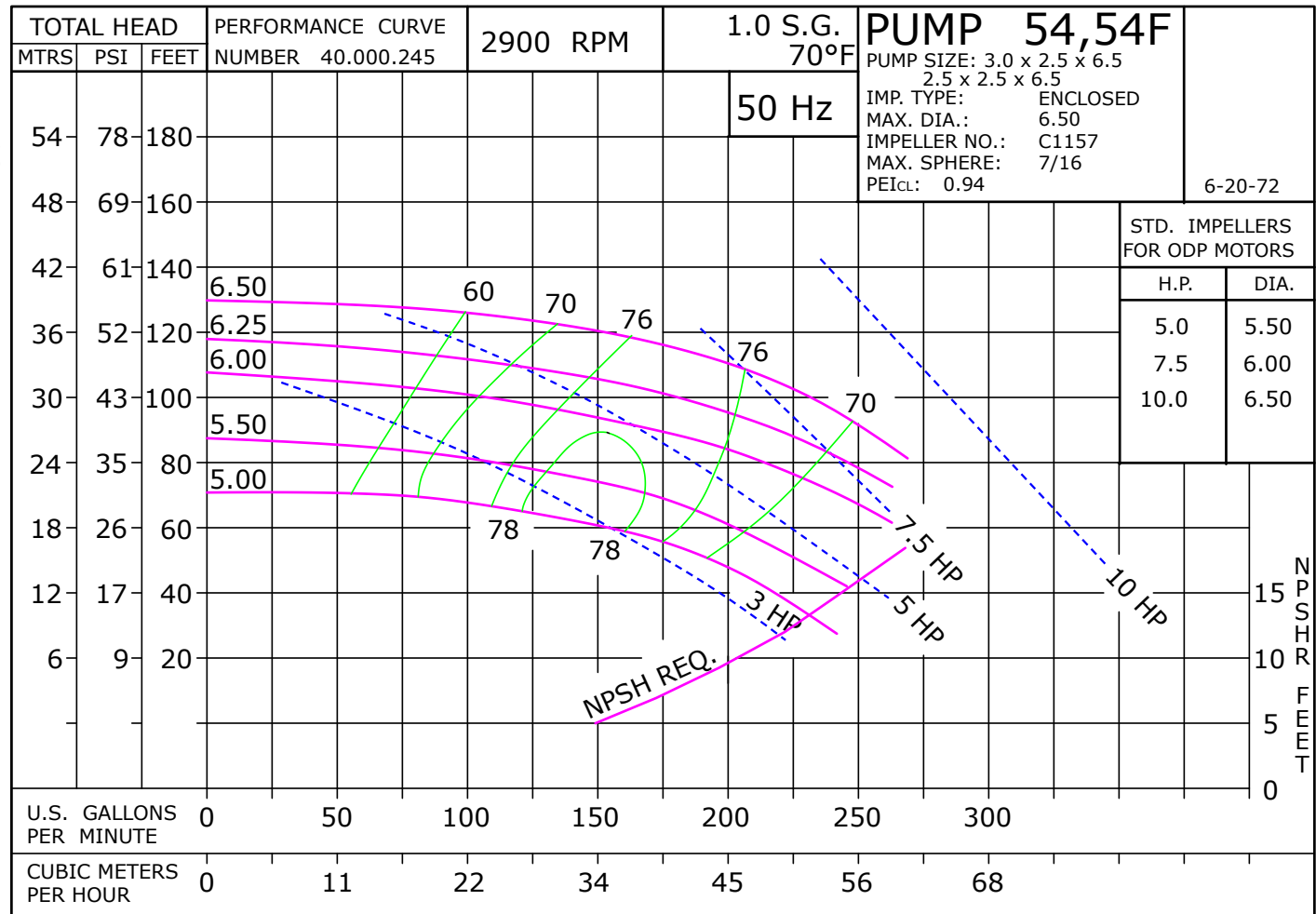
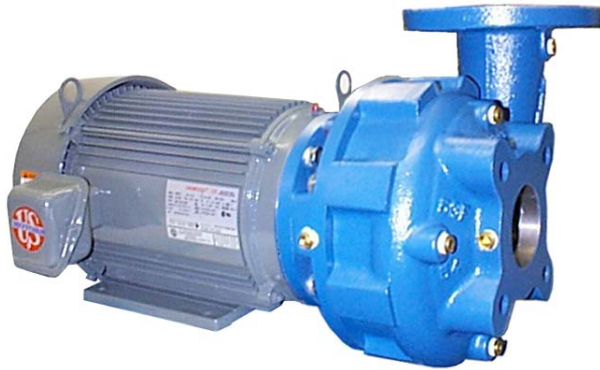

054F10TE

D1484
0542900

54F JM

054F2900JM
81.001.407

A20

50 Hertz Pump & Motor Data

A 3-phase 50 Hertz Motorpump™ can be obtained in several ways. The most common options are listed below:

1. Most 60 Hz pumps available from Scot Pump can be operated on a 3-phase 50 Hz 190/380V power. However, when operated on 50 Hz power, the speed is reduced by approximately 20%, and a significant reduction in performance is realized. The charts below indicate these reductions in performance.
2. Pumps will produce the performance indicated in the performance curves when operated on 50 Hz power. The motors for these selections can be obtained through *derated 60 Hz motors* and *wound 50 Hz motors*.

Contact factory for 1 Phase applications.

Derated 60 Hz Motors

The most common practice and readily available method of obtaining a 50 Hz motor is by using the next larger 60 Hz motor and derating it to the desired horsepower on 50 Hz. Many High Efficient motors can be operated on 50 HZ power without a reduction in horsepower. The motor manufacturers 60 HZ nameplate will remain intact. An "Alternate Motor Rating" nameplate indicating the reduced horsepower, RPM, volts, amps, and service factor will be affixed to the pump. In utilizing this practice, service factors may be derated to 1.0. The standard voltage is 190/380V and has a ±10% voltage variation. In addition, 200/400V and 208/416V may be available. Please contact the factory for approval of the rating for your specific application.

Wound 50 Hz Motors

Specially wound 50 Hz 220/380V six-lead Delta Wye motors are available. Most ratings offer a ±15% voltage variation. These motors are not normally a stock item and require an extended lead time.

The impeller and horsepower combination sized (taking the reduction in speed into consideration) may not be suitable for operation on 60 Hz power. The increase in speed, performance and load may overload the system and the electric motors. **Pumps sized for 50 Hz operation SHOULD NOT be tested on 60 Hz.**

60 Hz Pump on 50 Hz Power		
No Impeller Change		
50 Hz	60 Hz	Factor
GPM =	GPM x	0.829
Head =	Head x	0.687
BHP =	HP x	0.569

To Size 60 Hz Pump Using 50 Hz Data,		
Obtain 60 Hz Data As Follows:		
60 Hz	50 Hz	Factor
GPM =	GPM x	1.2
Head =	Head x	1.45
BHP =	HP =	$\frac{\text{GPM} \times \text{Head} \times \text{SG of}}{3960 \times \text{Eff}}$

Change of Speed (RPM)		
	How Varies:	Examples
GPM	Directly	Double RPM = (2)(RPM) = (2)(GPM) Triple RPM = (3)(RPM) = (3)(GPM)
Head	Square	Double RPM = (2)(RPM) = (2) ² = (2)(2) = (4)(Head) Triple RPM = (3)(RPM) = (3) ² = (3)(3) = (9)(Head)
BHP	Cube	Double RPM = (2)(RPM) = (2) ³ = (2)(2) (2) = (8)(BHP) Triple RPM = (3)(RPM) = (3) ³ = (3)(3)(3) = (27)(BHP)

Change of Impeller Diameter (Dia.)		
	How Varies:	Examples
GPM	Directly	Double Dia. = (2)(Dia.) = (2)(GPM) Triple Dia. = (3)(Dia.) = (3)(RPM)
Head	Square	Double Dia. = (2)(Dia.) = (2) ² = (2)(2) = (4)(Head) Triple Dia. = (3)(Dia.) = (3) ² = (3)(3) = (9)(Head)
BHP	Cube	Double Dia. = (2)(Dia.) = (2) ³ = (2)(2) (2) = (8)(BHP) Triple Dia. = (3)(Dia.) = (3) ³ = (3)(3)(3) = (27)(BHP)

Pump 54F • Iron • JM Frame • 2900 RPM

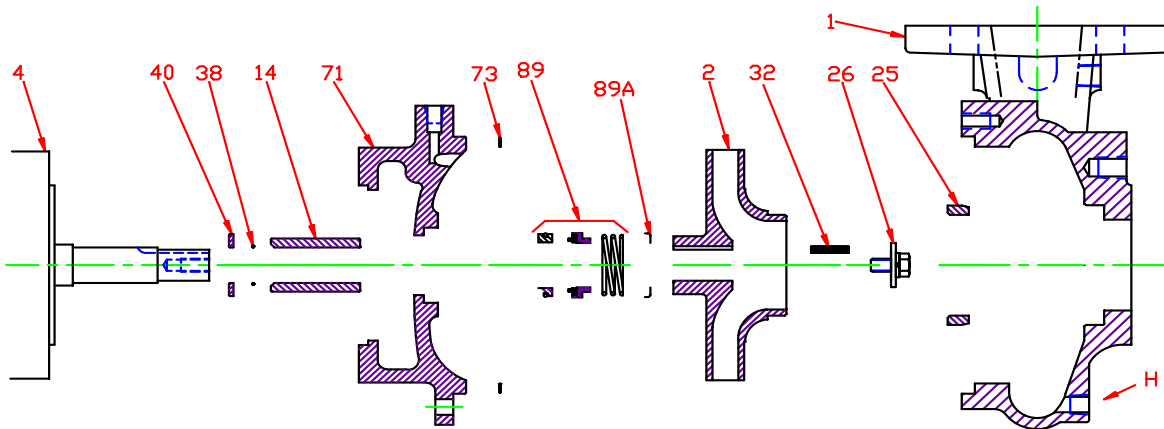

KEY NO.	PART NAME	PUMP NO. 54F
1+	CASE, IRON, 2.5 x 2.5 FLG	130.000.184X
2	IMPELLER, 7/8" KEYED, ENCLOSED, SPECIFY DIAMETER:	
	IRON	131.000.812
	BRONZE	131.000.825
4	MOTOR, JM140/180	See 60HZ Chart
	MOTOR, JM210	See 60HZ Chart
14*	SHAFT SLEEVE, BRONZE	110.000.178
	SHAFT SLEEVE, STAINLESS	110.000.192
25	WEAR RING, BRONZE	103.000.137
	WEAR RING, STEEL	103.000.153
26*	IMPELLER RETAINER, STAINLESS	118.000.163A
32*	KEY, STAINLESS	102.000.102
38*	O-RING, SHAFT, BUNA	116.000.117
	O-RING, SHAFT, VITON	116.000.105
40*	FLINGER, STAINLESS	104.000.165
71	ADAPTER, IRON - JM140/180	132.000.202X
	ADAPTER, IRON - JM210	132.000.213X
73*	GASKET, CASE, FIBER	116.000.157
89*	1½" SEALS:	
	BN-CARB/CM	101.000.168
	VN-CARB/CM	101.000.191
	VN-CARB/SIL	101.000.175
	VN-SIL/SIL	101.000.204
	EPDM-CARB/SIL	101.000.175B
	EPDM-SIL/SIL	101.000.204A
89A*	SEAL RETAINER, STAINLESS	104.000.174
--	° REPAIR KITS:	
	BN-CARB/CM SEAL	118.000.344
	VN-CARB/CM SEAL (S)	118.000.344A
	VN-CARB/CM SEAL	118.000.344K
	VN-CARB/SIL SEAL	118.000.344B
	VN-SIL/SIL SEAL (S)	118.000.344F
	EPDM-CARB/SIL SEAL	118.000.344C
EPDM-SIL/SIL SEAL	118.000.344D	

* DENOTES COMPONENTS INCLUDED IN REPAIR KIT.

+ INCLUDES BRONZE WEAR RING. FOR STEEL WEAR RING, REPLACE SUFFIX "X" WITH "X1".

° ALL REPAIR KITS INCLUDE THE BRONZE SHAFT SLEEVE EXCEPT THE (S) INDICATED, WHICH IS STAINLESS WITH VITON SHAFT O-RING.

Pump 54F • Iron • JM Frame • 2900 RPM

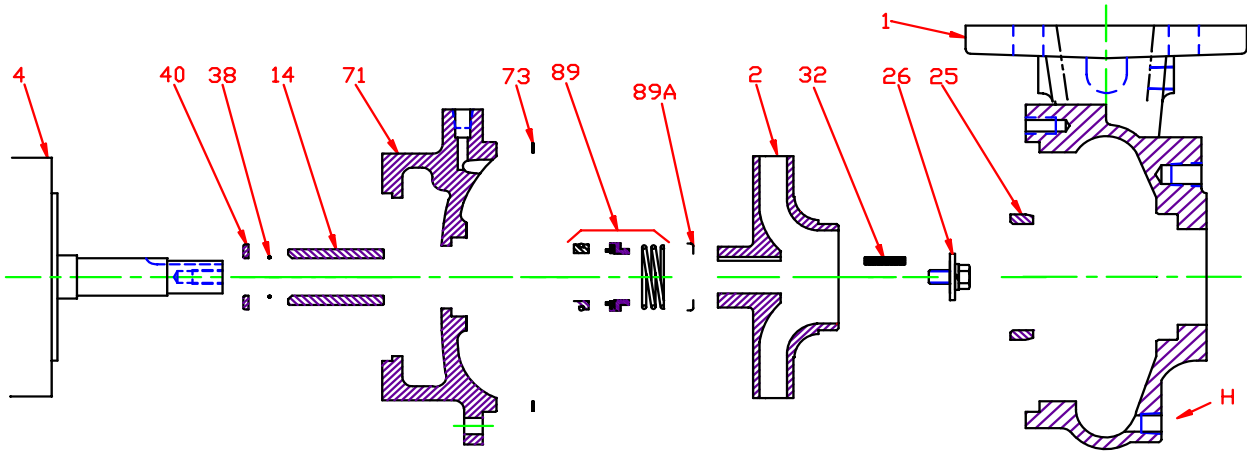

CONSTRUCTION OPTIONS

KEY	PART NAME	STANDARD FITTED	BRONZE FITTED	ALL IRON
1	Case	Iron	Iron	Iron
2	Impeller	Iron	Bronze	Iron
14	Shaft Sleeve	Bronze	Bronze	Stainless
25	Wear Ring	Bronze	Bronze	Steel
26	Impeller Retaining Assy	Stainless	Stainless	Stainless
32	Key	Stainless	Stainless	Stainless
38	Shaft O-Ring	BUNA	BUNA	BUNA
40	Flinger	Stainless	Stainless	Stainless
71	Adapter	Iron	Iron	Iron
73	Gasket, Case	Fiber	Fiber	Fiber
89	Mechanical Seal, Type 21 BN-CM	Standard	Standard	Standard
89A	Seal Spring Retainer	Stainless	Stainless	Stainless
H	Plug, Drain	Brass	Brass	Plated Steel

E054FJM

B11

C054F2900JM