



482 Series EGB End Gun Booster Pumps

Installation and Operating Manual

Inspection

Check shipment for shortage and damage immediately upon arrival. Note damage or shortage on freight bill (bill of lading); immediately file claim with carrier.

EXTERIOR — Pay particular attention to conduit box, external hardware, and accessories. Touch up abrasions or scratches with approved paint.

INTERNAL — If extensive or serious external damage is noted, if impeller is damaged (look in ports), or if shaft binds or sticks, disassemble as required to permit internal inspection.

Handling

Handle with care. Dropping or jarring can seriously damage motor bearings or break pump parts. Lift with device having capacity for pump weight, and use lifting hooks or eye bolts (if provided) or rig double sling around motor frame and pump casing. Do not use sling through pump motor adapter nor around suction or discharge flanges.

Installation

Location — Pump location should provide the following:

1. Install as close to suction supply as possible.
2. Shortest and most direct suction pipe practical. Suction lift must not exceed limit for pump. NPSH available must equal or exceed pump requirement.
3. Suction port below fluid level to provide priming.
4. Room for inspection and maintenance.
5. Correct power supply to motor; all wiring should meet National Electrical and Local Codes and Regulations.
6. If outdoors, protection from the elements, freezing and water damage due to flooding.

Piping — Suction and discharge gauges are useful to check pump operation and are excellent trouble indicators. Install gauges in the lines if pump ports do not have gauge taps. Observe these precautions when installing piping:

1. Support close to, but independently of pump.
2. Use the next larger pipe size for suction and discharge.

3. Keep as straight as possible. Avoid bends and fittings.
4. Remove burrs and sharp edges, ream pipe cuts, and make joints air-tight.
5. Don't spring pipe to make connections. Strain must not be transmitted to pump.
6. Allow for pipe expansion with hot fluids; expansion joints are not recommended.

Suction — Size and install suction piping to keep pressure loss to a minimum and to provide correct NPSH by observing the following:

1. The suction pipe should be equal in size or preferably one size larger than the suction connection of the pump. If pipe is larger than the pump suction, an eccentric pipe reducer should be used at the pump.
2. Pipe should slope upward to pump, even for horizontal run.
3. Use 45-degree or long-sweep 90-degree elbows.
4. A valve in the suction is necessary only on positive suction head installation and must not be used to throttle the pump. The suction valve should be installed for maintenance purposes only.

Discharge — Pumps permit discharge port location at any of four positions, 90 degrees apart. Change by removing cover bolts, rotating casing, and replacing bolts. Do not slice O-ring. AMP does not recommend bottom vertical discharge due to erratic pump performance. Ensure there is adequate clearance with selected position between wall or tank, motor conduit box, and grease fittings. Casing may extend beyond base or feet.

1. Short discharge lines may be the same size as the discharge port. Long runs require a pipe larger than the discharge port.
2. Long horizontal runs require a grade as even as possible. Avoid high spots and loops. Trapped air will throttle flow and may result in erratic pumping.
3. Install check and gate valves in discharge line; check valve (if used) between pump and gate valve.

Operation

Pre-Start — Before initial start of the pump, check as follows:

1. The rotation must be checked upon installation. Close, then break the contacts quickly and observe the rotation of the exposed portion of the rotating parts. Rotation must agree with the rotation arrow on the motor. For all pumps, the standard rotation is counterclockwise when viewed from the suction end. Motor wiring is easily changed in the field. Observe the wiring diagram on the inside of the terminal box cover, or on the motor nameplate.
2. Check voltage, phase and frequency of line circuit with motor nameplate.
3. Check suction and discharge piping and pressure gauges for proper operation.
4. Assure that the pump is full of liquid (primed).

Priming — If pump is installed with a positive head on the suction, prime by opening suction valve and allowing liquid to enter the casing, at the same time venting all air out of the top of the casing. If pump is installed with a suction lift, priming must be done by other methods, such as foot valves, ejectors, or by manually filling casing and suction line.

CAUTION - DO NOT RUN PUMP DRY. Serious damage may result if started dry.

Starting — Proceed as follows to start pump:

1. Close drain valves and valve in discharge line.
2. Fully open all valves in the suction line.
3. Prime the pump. If pump does not prime properly, or loses prime during start-up, shut down and correct condition before repeating procedure.
4. For pumps moving high temperature liquids, open warm-up valve to circulate liquid for preheating. Close valve after pump has warmed up.
5. Start the motor (pump).
6. When pump is operating at full speed, open discharge valve slowly.

Running — Periodically inspect pump while running, but especially after first start and following repair.

1. Check pump and piping for leaks. Repair immediately.

2. Record pressure gauge readings for future reference.
3. Record voltage, amperage per phase, and kW (if an indicating wattmeter is available).
4. Adjust pump output capacity with discharge valve. DO NOT throttle suction line.

Freezing Protection — Protect pumps shut down during freezing conditions by one of the following methods:

1. Drain pump; remove all liquid from the casing.
2. Keep fluid moving in pump and insulate or heat the pump to prevent freezing. If heated, do not let temperature go above 100 to 150 degrees F.
3. Fill pump completely with antifreeze solution.

Maintenance

Cleaning — Remove oil, dust, dirt, water, and chemicals from exterior of motor and pump. Keep motor air inlet and outlet open. Blow out interior of open motor with clean compressed air at low pressure. Regularly drain moisture from TEFC motors.

Temperature — Total temperature, not the rise, is the measure of safe operation for a motor. If temperature by thermometer exceeds limits for insulation class, investigate and change operating conditions.

Labeled Motors — It is imperative for repair of a motor with Underwriters' Laboratories label that original clearances be held; that all plugs, screws, other hardware be fastened securely, and that parts replacements be exact duplicates or approved equals. Violation of any of the above invalidates Underwriters' label.

Lubrication — Pumps should require no maintenance, other than the motor bearings, according to the following instructions:

DOUBLE SHIELDED. When double shielded prelubricated bearings are furnished, no lubrication is required for the life of the bearings. Inspect bearings periodically to determine the condition of the grease and replace the bearings if necessary.

SINGLE SHIELDED W/GREASE FITTING PROVISIONS. When single shield bearings are furnished, periodic inspection, cleaning and relubrication is required. See motor manufacturer's specific instructions for lubrication.

Mechanical Seal Replacement

A.) Disassembly:

1. Turn off power.
2. Close suction and discharge valves.
3. Drain pump.
4. Remove bolts holding base to foundation
5. Remove casing bolts.
6. Remove motor and rotating element from casing, leaving casing and piping undisturbed.
7. Remove drip cover from motor end. (Figure 1)

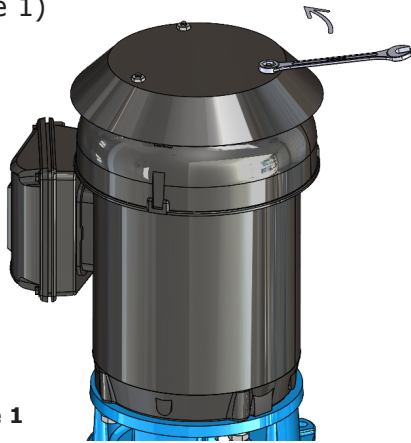

Figure 1

8. Place a strap wrench around the impeller outer diameter. While holding strap wrench against rotation, unscrew the impeller locking nut in eye using a 1/4-inch Allen wrench or Allen socket. (Figure 2)

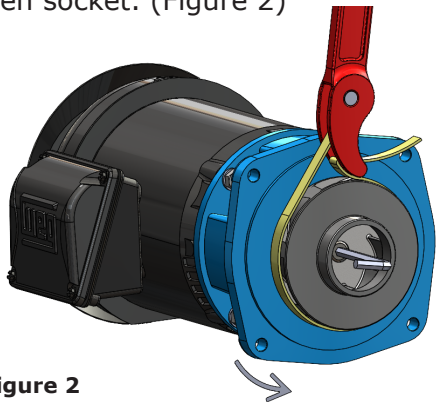

Figure 2

9. Remove motor shaft end cap at the back of motor (opposite the pump end).
10. Insert a screwdriver in slot of motor shaft end. While holding screwdriver against rotation, use a strap wrench around impeller outer diameter to unscrew the impeller counterclockwise from the motor shaft. (Figure 3)

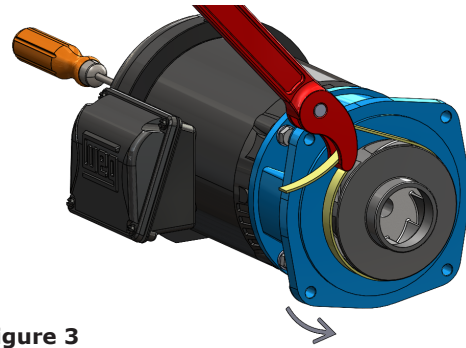

Figure 3

11. Remove bolts holding adapter to motor. Lightly tap the adapter from side to side away from the motor using a rawhide or hard rubber hammer to achieve a large enough gap to insert screwdrivers between the adapter face and the motor face. Using two screwdrivers 180 degrees apart, evenly pry the adapter with the seal assembly away from the motor until rotary seal is free of motor shaft. Be careful not to insert screwdrivers too far to prevent contacting and damaging the motor shaft. (Figure 4)

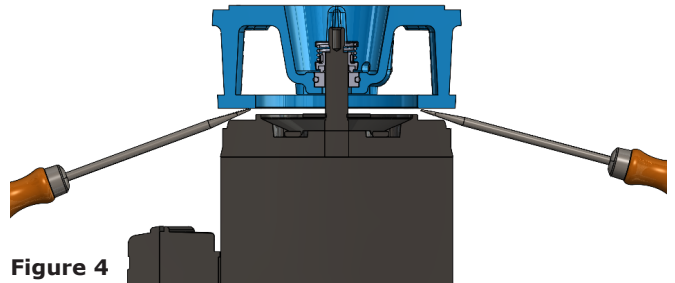

Figure 4

12. Place adapter on a flat surface with case rabbet facing down, and push out stationary part of mechanical seal.

B.) Reassembly:

1. Clean flange faces, seal seat cavity, and shaft- especially the face fitting against impeller.
2. Place adapter on a flat surface with motor side facing down. Position the stationary seat with the silver dot down (away from you) and the lapped face (shiny side) facing you. Lubricate the seal seat cavity of the adapter and the rubber cup or O-ring of stationary seal seat with the lubricating fluid that comes with the mechanical seal or repair kit. Press the stationary seat in seal seat cavity of the adapter squarely and evenly using an arbor press (if possible) and the cardboard disc supplied with the seal. Be certain that the lapped face (shiny side) is facing you.

Reassembly, cont...

3. Remount the adapter on motor, making sure the motor shaft does not dislocate or chip the stationary seat of the seal.
4. Apply the lubricating fluid that comes with the mechanical seal or repair kit to the motor shaft and the rubber bellows of the rotary seal. Slide the seal head on the shaft, press the rubber drive band on the rotary head until the lapped face on the head seats firmly against the lapped face of the stationary seat. Do not chip or scratch faces during installation. Take extra care to make sure the lapped faces are clean. Install spring on seal head (only applies to Type 21 seal).
5. Hold shaft against rotation as described in paragraph 10 of disassembly procedure, and thread impeller on shaft until it is tight against the shaft shoulder. The impeller will compress the seal spring to the proper length assuring correct pressure on lapped faces.
6. Replace impeller locking nut while holding impeller against rotation as indicated in paragraph 8 of disassembly procedure (2 & 3 HP 1PH, and all 3PH motors only).
7. Replace protective motor shaft end cap.
8. Replace drip cover on motor end.
9. Replace motor and rotating element in casing. Be sure that any damaged O-ring or gasket is replaced.

10. Apply thread sealant to case bolt ends and inside case threads (Figure 5). Thread sealant is not supplied with repair kits.

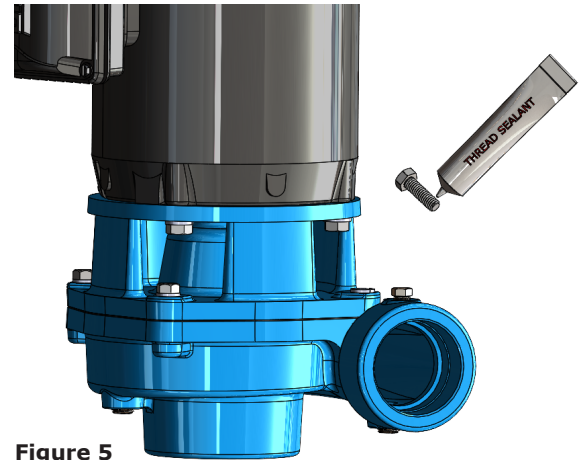

Figure 5

11. Tighten casing bolts alternately and evenly.
12. Replace hold-down bolts.
13. Check for free rotation after assembly is completed.
14. Seal all drain openings using pipe sealant on threads.
15. Reprime before starting. Do not start until pump is completely filled with water.

The approved lubricating fluid for seal installation is included with the mechanical seal or repair kit.
DO NOT USE OTHER LUBRICATING LIQUIDS!

WE RECOMMEND STOCKING A SPARE MECHANICAL SEAL OR REPAIR KIT TO ELIMINATE DOWN TIME.

Pressure and Temperature Limitation				
Standard Fitted Pumps				
Pump No.	Pressure		Temperature	
482 EGB	75 PSI	150 PSI	220°F	275 °F
CAUTION				
DO NOT ALLOW EITHER THE DISCHARGE PRESSURE OR THE TEMPERATURE OF THE LIQUID TO EXCEED THE LIMITATIONS LISTED ABOVE.				

American-Marsh Pumps

T +1 901-860-2300
www.american-marsh.com
amp.cs@wilo.com

