

Pioneering for You

wilo

Product brochure

Wilo-Sevio ACT, the process optimiser.





Efficiently increasing treatment performance

with innovative technology from Wilo.

Operators of waste water treatment plants are increasingly confronted with new challenges. Cities are expanding, resulting in waste water treatment plants often being incorporated into suburban areas and being burdened by an increased number of inhabitants. Mainly due to opposition from these inhabitants, expansion of the waste water treatment plant is out of the question, meaning that treatment performance cannot be improved by additional constructions.

Increasingly higher demands are also made on the treatment of industrial waste water. Whether it's changes to production processes or new legal requirements, highly flexible and safe process engineering is what's called for.



Current processes, such as classic sludge activation or the biofilm method, are stretched to their limits again and again as a result of these increasing demands.

Modifying or converting plants to incorporate processes that use biomass carriers is ground-breaking and efficient. This method optimises the treatment process and also reduces the need for secondary treatment.

The aim is to keep the biomass carrier particles moving freely in the basin using the innovative Wilo-Sevio ACT in order to optimise the biological process.

Tailor-made for your requirements

- For the biological treatment of municipal and industrial waste water, for example in the areas of carbon decomposition, nitrification and denitrification
- Designed especially for waste water treatment plants that are not permitted to expand in size
- Ideal for industrial waste water treatment plants in the areas of food and animal feed manufacturing and the production of steel, chemicals and paper
- Suitable for various basin depths and geometries
- For all types of biomass carrier particles
- Can also be used for suctioning floating sludge

Optimised treatment process

by entering biomass carrier particles gently into the fluid.

Classic sludge activation firstly requires a lot of space. Secondly, sedimentation in secondary clarifiers frequently poses a challenge. Conventional biofilm systems, such as percolating filters, rotating biological contactors, immersed fixed beds or biofilters, require a large amount of space, too. A further problem is posed by the even distribution of organic load in activated sludge tanks and fixed-bed reactors.

The ground-breaking method using biomass carrier particles combines the benefits of classic sludge activation and the well-known biofilm method. On the one hand, the entire basin volume is used just like in the sludge activation method. On the other hand, the biomass carrier particles are distributed and moved freely in the water by means of even mixing.

Biomass that becomes detached from the carrier is taken out as excess sludge and removed during secondary treatment. Secondary treatment can be designed significantly smaller seen as no sludge has to be returned in most cases.

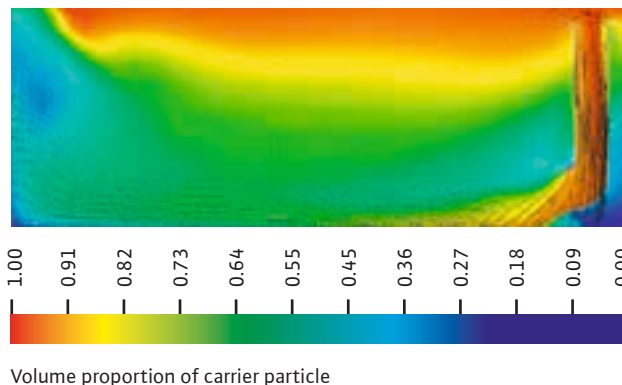

The advantages to you

- Reduced energy costs
- Low investment costs
- Improved treatment performance
- High process reliability
- Even mixing and reduced deposition
- Easy installation
- Can be retrofitted at any time

Benefit from our know-how

The fully immersed Wilo-Sevio ACT components allow the flow pulse to take effect from the most favourable hydraulic point. This improves the economic efficiency of your entire process.

This is made possible by a combination of the following:

- Computer-based design
- Simulation of flow profiles
- Individual adjustment to the respective system – optimally matched individual components

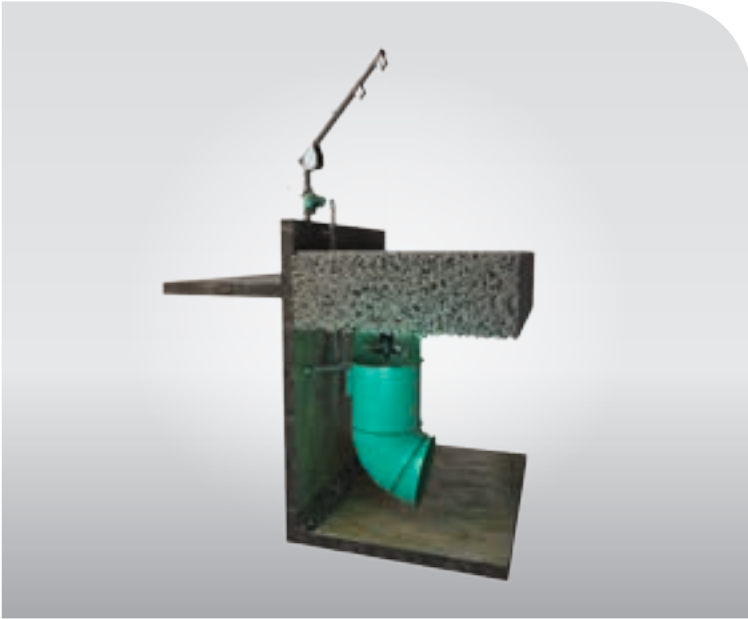

Floating cover of biomass carrier particles

The carrier particles located on the top layer and mostly not in the waste water are not available for biological degradation. Using the Wilo-Sevio ACT the carrier particles are sucked in and fed back into the biological process underneath the water's surface.

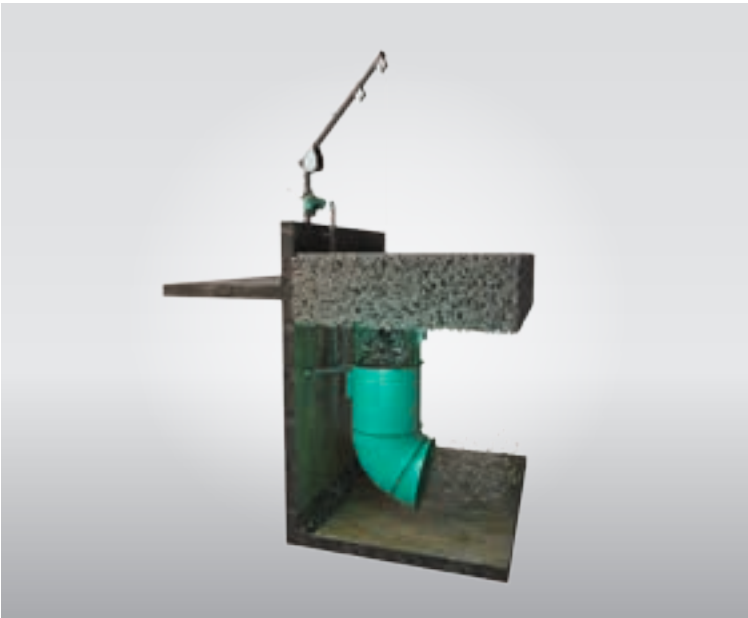

Sucking in the biomass carrier particles

The Wilo-Sevio ACT ensures that the carrier particles are continuously distributed and entered gently in order to protect the growth on them. Due to the outlet being located near the ground, deposition is minimised and even mixing achieved.

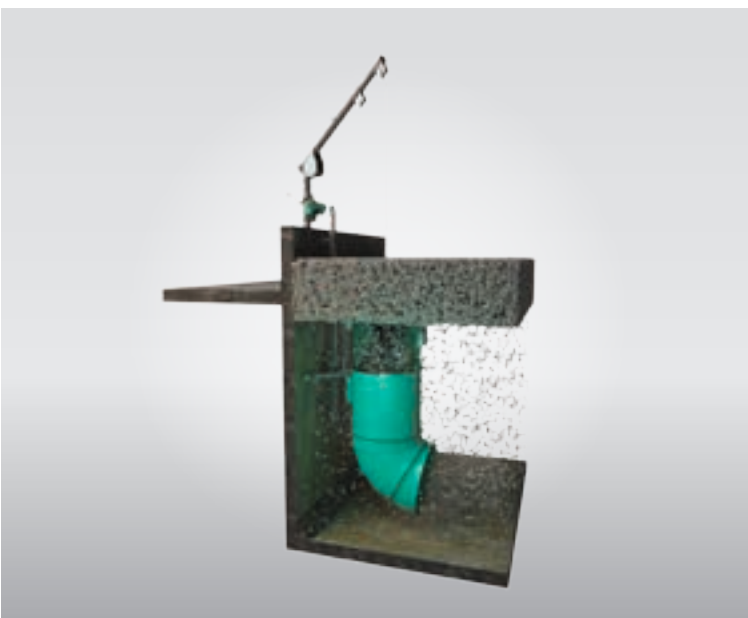

Even distribution

The higher the number of carrier particles that react with the fluid, the better the treatment performance. Our individual configuration and the innovative technology of our Wilo-Sevio ACT ensure optimal treatment results.

Wilo-Sevio ACT.

The advantages to you at a glance.



System-optimised
Energy-optimised circulation thanks to individual configuration and efficient components



Practical
Simple installation and maintenance using lowering devices and auxiliary hoisting gear



Process-optimised
Adjustment of circulation effect by individually setting the discharge angle and direction

Calculation example for optimised configuration			
	Pneumatic circulation*	Submersible mixer	Wilo-Sevio ACT
Annual operating time	8,760 h	8,760 h	8,760 h
Energy costs	0.15 €/kWh	0.15 €/kWh	0.15 €/kWh
Basin volume	600 m ³	600 m ³	600 m ³
Energy input	45 W/m ³	30 W/m ³	10 W/m ³
Power consumption in duty point P1.1	27 kW	18 kW	6 kW
Energy costs per year	8,760 h × 0.15 €/kWh × 27 kW = € 35,478	8,760 h × 0.15 €/kWh × 18 kW = € 23,652	8,760 h × 0.15 €/kWh × 6 kW = € 7,884
Total energy costs over 5 years**	€ 177,390	€ 118,260	€ 39,420

Potential energy savings over 5 years** for Wilo-Sevio ACT compared to	Pneumatic circulation*	Submersible mixer
	€ 137,970	€ 78,840

* E.g. for bioreactors in industrial applications.

** Energy costs calculated at a constant rate of 0.15 €/kWh.

Technical data

Wilco-Sevio ACT SD 101 ...

Diameter	900 mm
Flow rate	3,300–4,000 m ³ /h
Rated motor power	3–4.5 kW
Propeller speed	200–250 rpm
Power input	6–10 W/m ³

Scope of delivery

Lowering device including fastening elements, unit with 10 m cable (excess lengths on request). Any necessary changes to the construction (e.g. railings, covers, bridges, pedestals) are to be made onsite. This includes the supply of power. The operator is responsible for proper operation and the compliance of all accident prevention, safety and hygiene regulations. Free access as well as safe operation and installation are to be ensured.

Wilco-Sevio ACT SD 101	Basin depth	Max. floating layer thickness	Max. proportion of biomass carrier particles
Standard 30°/DF238...	4/(3 + sloping bottom) m	1.6 m	50 %
Standard/VF273...	4 m	1.9 m	50 %
Telescope/VT435...	6 m	3.5 m	60 %
Telescope long/VT615...	≥ 8 m	5.3 m	70 %

Dimension drawing of installation

Wilco-Sevio ACT SD 101 ...	Ø A/mm	B/m	C/m	D/m	F/kg
DF238...	1,010	≤ 2,375	≤ 2,290	1,250	270–305
VF273...	1,010	≤ 2,730	≤ 1,925	1,100	260–295
VT435...	1,010	3,650–4,350	≤ 1,925	1,000	360–395
VT615...	1,010	4,550–6,150	≤ 1,925	1,000	420–455

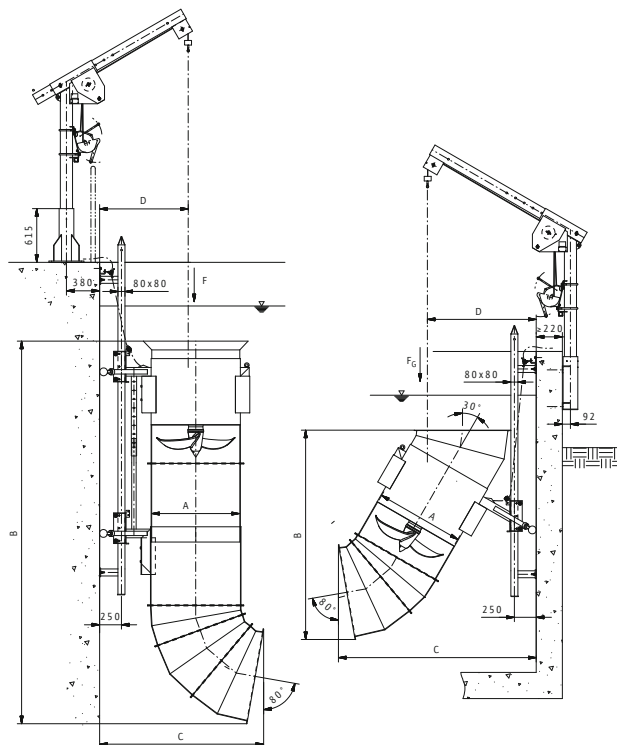



WILO SE
Nortkirchenstraße 100
D-44263 Dortmund
Germany
T +49 231 4102-0
F +49 231 4102-7363
wilo@wilo.com
www.wilo.com

Pioneering for You

More contact details at www.wilo.com