

Pioneering for You

wilo

Product brochure

**Sewage transport and drainage –
as individual as your requirements are.**

Wilo-EMU FA.



With **SOLID**
impellers and
IE3 motors

Wilo

Pioneering for You.



We are there for you worldwide.

Since 1872, we at Wilo have been turning visionary ideas into intelligent solutions that regularly set new standards in the industry. The goal of our company founder, Caspar Ludwig Opländer, was to use his copper and brass goods factory to improve and facilitate the supply of water to people. It did not take long for the company to take the key step: in 1928, his son Wilhelm designed the world's first circulation accelerator.

We have been continuing this tradition ever since with pioneering innovations in the heating, air-conditioning and cooling sector, such as the world's first high-efficiency pump, and at the same time we have proven our commitment to using valuable resources such as energy and water responsibly. Today the Wilo Group, headquartered in Dortmund, is represented across the globe as an all-round provider of pumps and pump systems for water management.

Cooperative support you can rely on.

With over 7,500 employees and 60 production and sales companies all over the world, we personally see to it that our customers' and users' needs and requirements – whether they are specialist consultants, operators, or general contractors – are met optimally every day. This means making your life and work as easy as possible with our products, solutions and services.

“Pioneering for You” is our permanent pledge of clear customer focus, unrelenting pursuit of quality, and of our special passion for techno-

logy. In times of dwindling natural resources, the responsible management of water is an extremely important task, which is why we are committed to providing pioneering developments, sustainable product solutions, and cooperative support to ensure you can rely on our solutions for the daily management of water. That's what we call Pioneering for You.



**“The best solutions
are created through
top partnership,
that's what I call Pioneering for You.”**

Daniel Busuioc, International Project Coordinator of Group Competence Team,
WILO SE, Hof, Germany

A systematic approach to sewage transport. With Wilo.



Wilo sewage expertise
at a glance

The scale of water management can be adapted flexibly to your requirements.

Wilo is the system expert who supports you with tailor-made solutions during all phases of the project. From design and configuration to commissioning and maintenance. This means we are just the right partner for the growing challenges posed by sewage disposal. This includes requirements for greater energy efficiency and cost-effectiveness, coping with increasing solid matter content in the sewage as well as burgeoning regulations and the stricter legal environment. One thing is certain: you can rely on us when it comes to pumping sewage.

1 Wastewater collection and transport

Cities and communities collect sewage in pumping stations, and have to transport this reliably to the wastewater treatment plant. It is important to guarantee operational reliability in spite of the increasing solid matter content. Thanks to its large free ball passages and different hydraulics, the Wilo-EMU FA is a reliable and functional solution to this challenge.

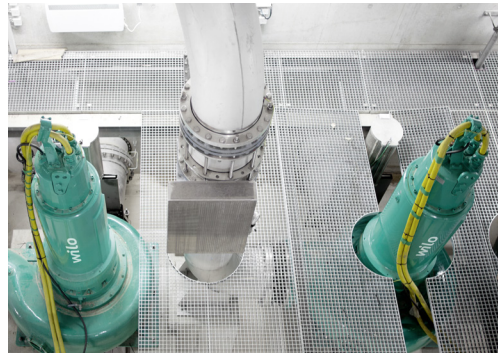

2 Drainage and flood control

Depending on the application, such as groundwater lowering or pumping out large quantities of water after flooding, the composition of the wastewater varies significantly. Here too, the Wilo-EMU FA submersible sewage pump provides an effective solution. Thanks to its diverse hydraulics, it can be adapted to almost all fluids and quantities. Performance that puts you in a position to plan the drainage.



3 Wastewater treatment

The Wilo-EMU FA is flexible in application and reliable in performance. This means it is suitable for the most varied range of applications in wastewater treatment plants. From the intermediate pumping station to the stormwater retention tank where the deposits are removed from the tank base in combination with a Wilo-EMU SR (jet cleaning).



Making the Wilo-EMU FA into your own Wilo-EMU FA. Individually configurable.

Nowadays, it is right and proper for people to be more sparing with the valuable natural resource of water. However, this increases the proportion of solid material in the sewage, and makes the transport question more and more complicated.

The simple solution from Wilo: the Wilo-EMU FA submersible sewage pump. This technology can be individually configured and thus adapted to suit practically all of your requirements. From drainage through to sewage transport. The wide bandwidth of different hydraulics and motor versions makes it possible for you to adjust the output of the Wilo-EMU FA precisely for your requirements – also with regard to durability. For pumping abrasive or corrosive fluids, the standard 2-component coating can be replaced by a Wilo-Ceram coating. This offers very good adhesion and is highly resistant to aggressive media because of its aluminium oxide constituents.

The Wilo-EMU FA – a pump adapted to your requirements. Bringing reliable pumping within your reach, from wastewater through to untreated sewage.

Overview of advantages:

- Can be customised exactly to your requirements
- Reliable operation thanks to ingenious and durable technology
- Reduced maintenance and operating costs
- Various Ex-ratings available (e.g. ATEX, FM, CSA)
- Suitable for immersed and non-immersed applications, even in continuous duty

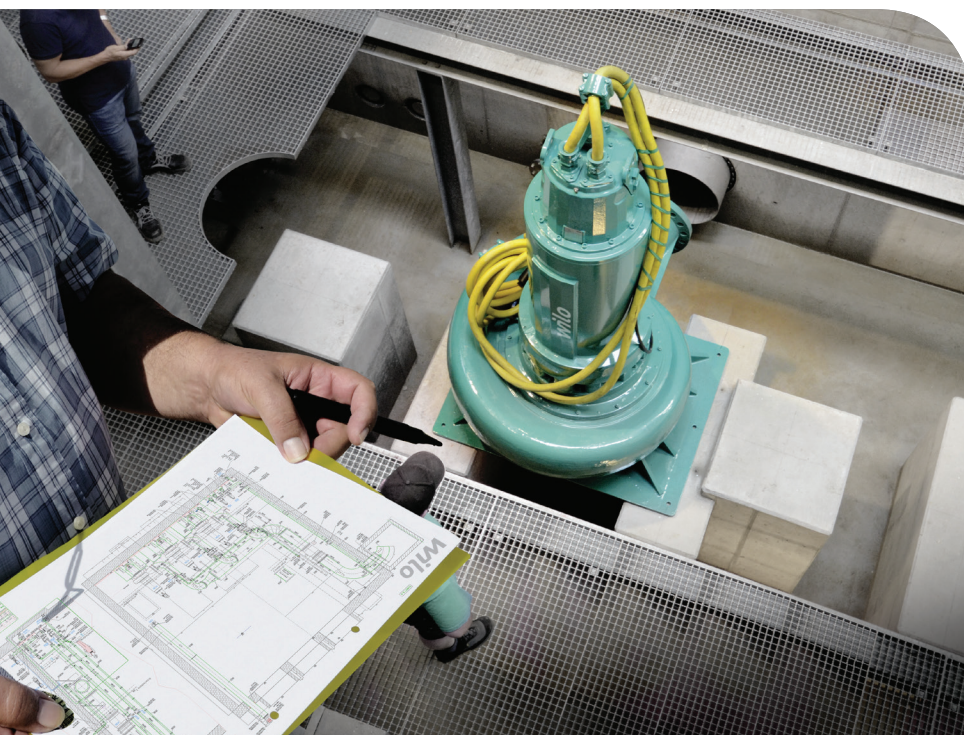

Monitored and assured efficiency according to plan.
Optimally solved with the Wilo-EMU FA.

Wilo-Control switchgear

- Level control by float switch, level sensors or dynamic pressure bell
- Simple operation by a button through to icon/text-based display
- Control of up to eight pumps including monitoring devices
- Optimum remote access via GSM, GPRS, Modbus or BACnet

Sophisticated motor technology

- Efficient motor technology for surface-cooled and self-cooling motors
- Suitable for immersed and non-immersed applications
- Extreme operating reliability due to a diverse range of monitoring options (e.g. motor winding, sealing chamber, motor bearing)
- Optionally with energy-efficient IE3 motor technology
- Variety of seal variants

Coatings and special materials

- Coated with high-quality 2-component paint as standard
- For corrosive fluids, the external surfaces can be coated with Wilo-Ceram C0
- Special materials for highly aggressive media on request

Variety of impeller variants

- Different impeller shapes for optimum pumping of different fluids at all times
- Hydraulic pump output optimally adapted to the desired duty point
- For abrasive fluids, the internal surfaces can be coated with Wilo-Ceram C1-C3

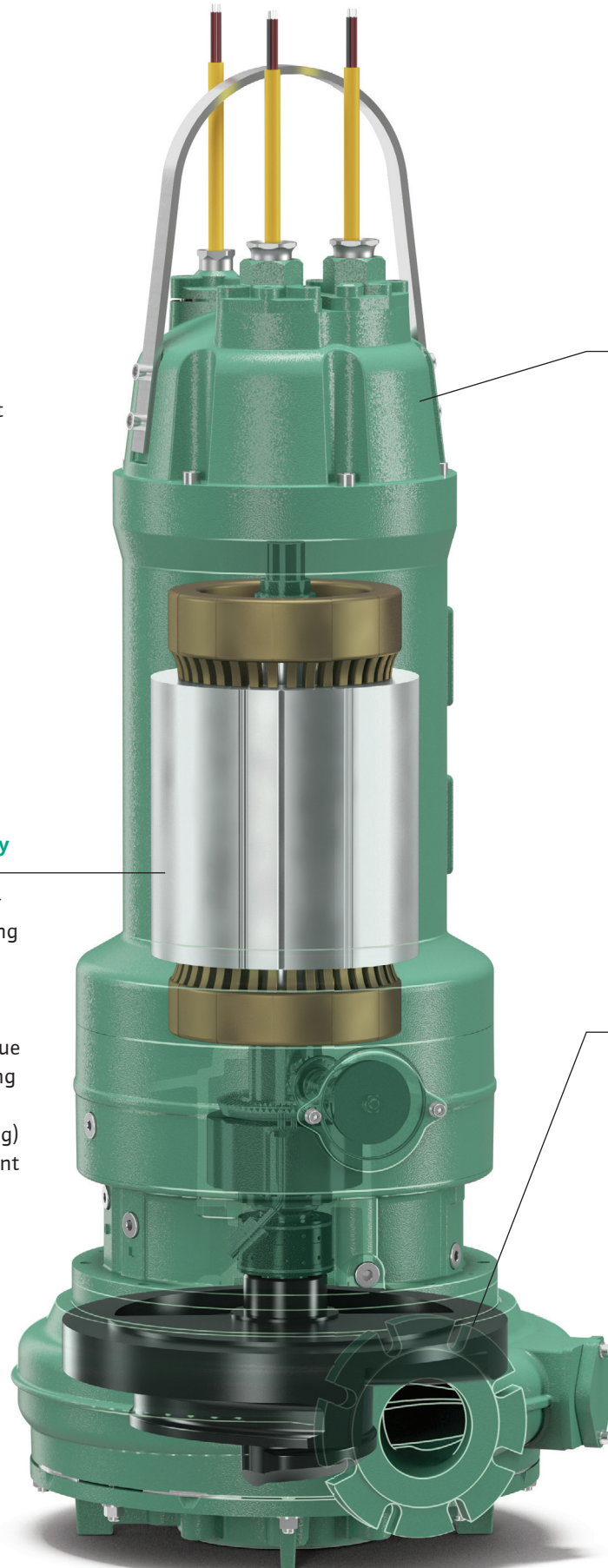

Wilo-EMU FA with SOLID-G impeller and FKT motor technology

Wilo-EMU FA.

The right impeller for practically any fluid.

Whether untreated sewage, pre-treated sewage or wastewater – optimum transport of different fluids requires the appropriate impeller. No single requirement is like another, so we carry a large number of impeller shapes in our range – from the vortex impeller through to multi-channel impellers and the SOLID impeller.

This means you can select an impeller for your Wilo-EMU FA that is adapted to your system and takes account of individual situations such as inflow conditions, delivery head and the type of fluid. The result is that you can count on efficient and reliable pumping operations. Irrespective of the composition of the fluid.

Visit us under www.wilo.com to find out all about our full-service package.

Comparison of efficiency and anti-clogging properties of the impellers.

When it comes to the hydraulic selection, it is necessary to consider the specific factors of the system such as inflow conditions, fluid composition or volume flow. During system optimisation, the aim is to find the best compromise between efficiency and process reliability.

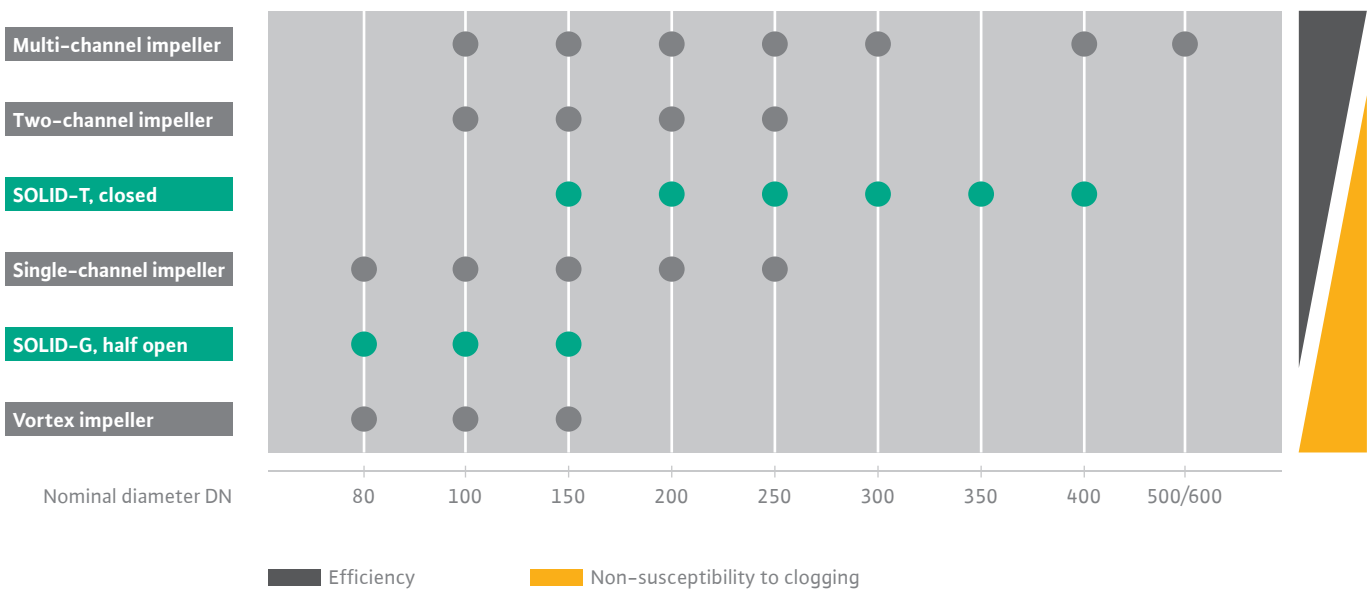

Subject to change without prior notice.

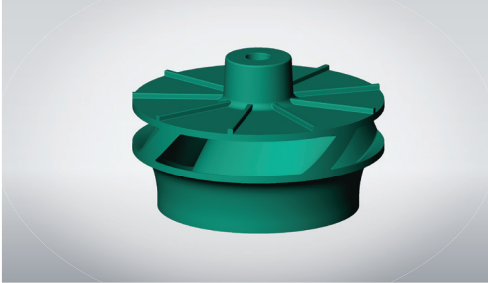

Closed multi-channel impellers (two, three, four-channel impellers)

- Pre-treated sewage
- Wastewater
- Activated and digested sludge

Technical data:*

Q_{\max} : 7,800 m³/h

H_{\max} : 103 m

Free ball passage: 50–130 mm

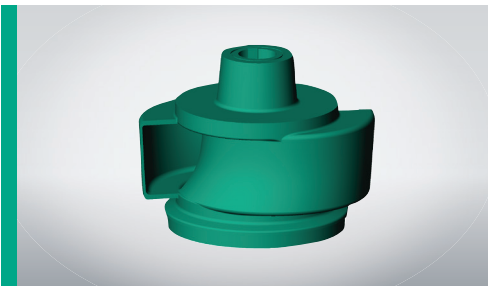

Closed SOLID-T impeller

- Untreated sewage
- Pre-treated sewage
- Activated and digested sludge

Technical data:*

Q_{\max} : 2,830 m³/h

H_{\max} : 55 m

Free ball passage: 78–170 mm

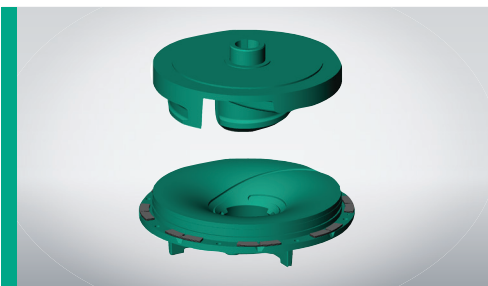

Half open SOLID-G impeller

- Untreated sewage
- Pre-treated sewage
- Activated and digested sludge

Technical data:*

Q_{\max} : 344 m³/h

H_{\max} : 61 m

Free ball passage: 80–90 mm

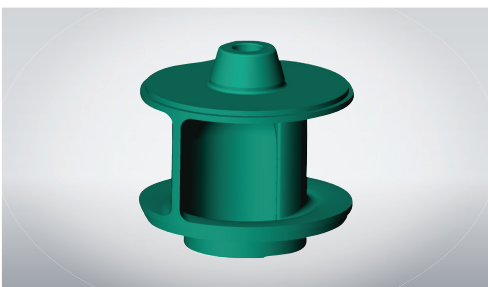

Closed single-channel impellers

- Untreated sewage**
- Pre-treated sewage
- Activated and digested sludge

Technical data:*

Q_{\max} : 1200 m³/h

H_{\max} : 40 m

Free ball passage: 45–200 mm

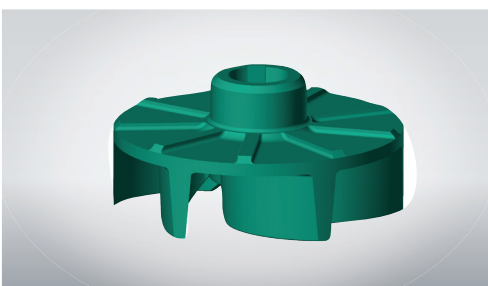

Vortex impeller

- Untreated sewage
- Pre-treated sewage
- Wastewater
- Activated and digested sludge
- Fluids with coarse constituents

Technical data:*

Q_{\max} : 418 m³/h

H_{\max} : 62 m

Free ball passage: 40–130 mm

* Technical data based on a 50 Hz mains connection.

** Depending on the free ball passage.

The SOLID series.

Your impellers for heavily contaminated sewage.

The higher the solid content of the fluid, the higher the risk of clogging. This represents a greater risk of disruptions in operation. In extreme cases, this can also mean higher service costs for you as the end-user. The solution is impeller technology with low susceptibility to clogging and high efficiency, especially for untreated sewage: SOLID. The impellers ensure greater operational reliability at the same time as reducing operating costs. Two SOLID variants are available – each of them is a high-performance, individual solution with high efficiency.

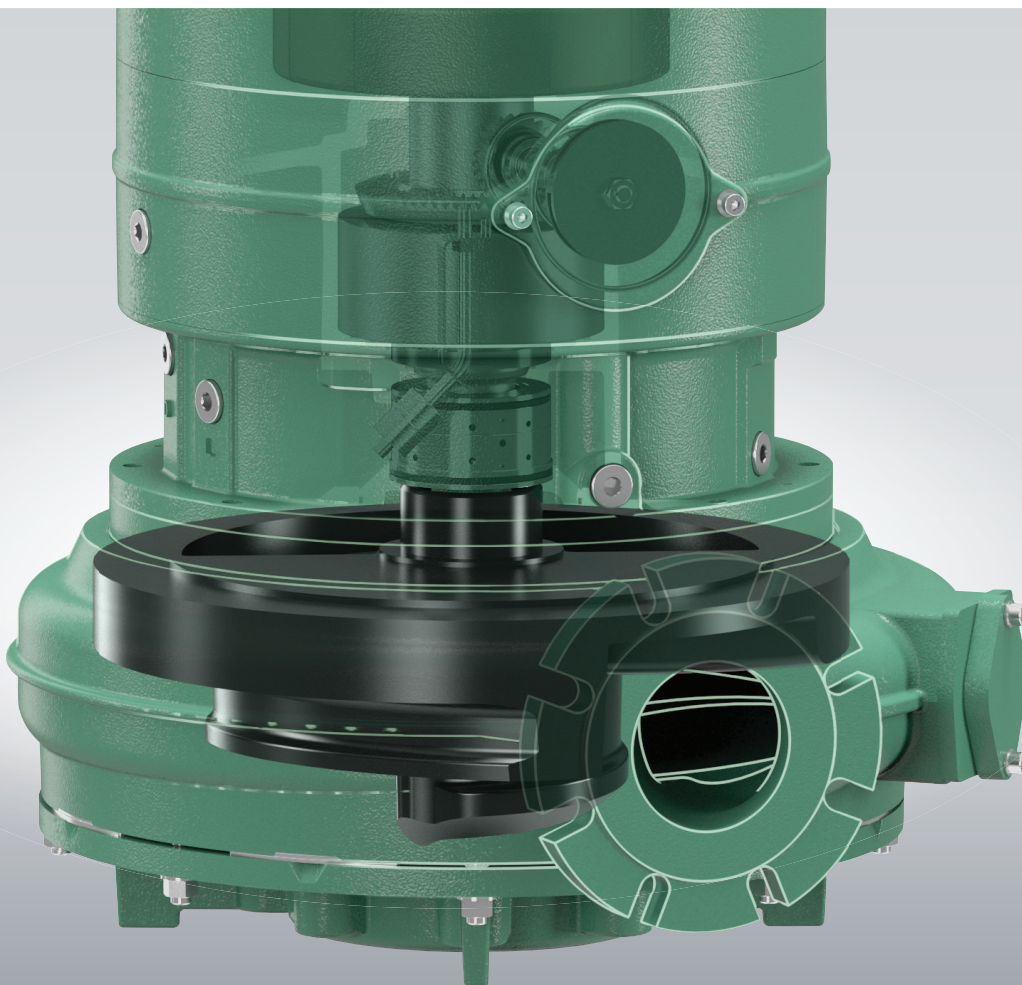

SOLID impeller technology. Reliable, low susceptibility to clogging, high efficiency.

The half open SOLID-G impeller.

Your choice for when you need to pump untreated sewage with an effective combination of consistently high efficiency and non-susceptibility to clogging – even when operated with partial loads and with long-fibre constituents. Adjustable suction port and reinforced blade edges on the pressure side ensure long-lasting efficiency and durability.

The closed SOLID-T impeller.

Excellently suited to pumping untreated sewage reliably and extremely efficiently. The impeller has large passage dimensions for particularly high efficiency. It runs particularly smoothly and with low vibration thanks to the optimised impeller geometry. The homogeneous flow course contributes to operational reliability.

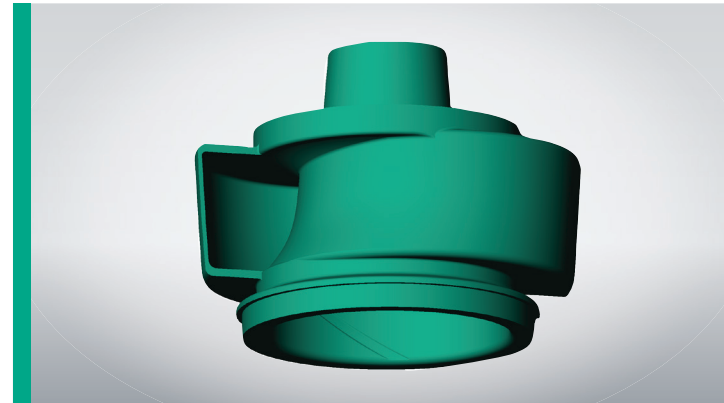
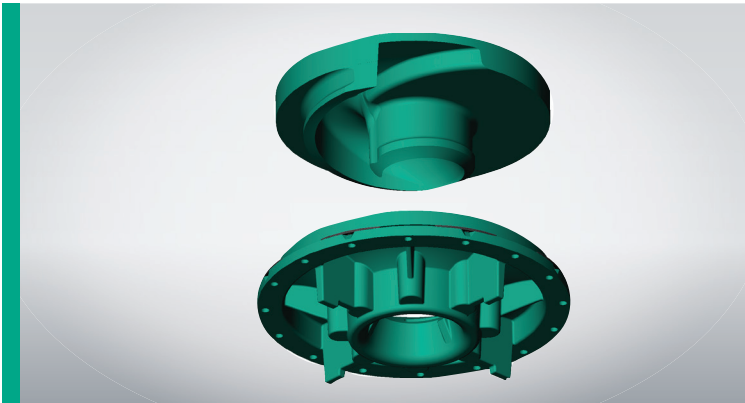

Overview of the advantages:

- Excellent operational reliability, even with untreated sewage
- Reduced energy costs in comparison to existing vortex impellers
- The perfect blend of efficiency and operational reliability
- Low maintenance costs thanks to non-susceptibility to clogging – even when operated with partial loads

A comparison between the overall costs makes it clear: A Wilo-EMU FA with SOLID-T impeller offers convincingly high efficiency paired with low energy costs, making it an efficient solution.

Wilo-EMU FA with SOLID impeller – economic comparison			
	Wilo-EMU FA 15.95E-317 + FK 202-4/27	Wilo-EMU FA 15.44W-363 + FKT 27.1-4/22	Wilo-EMU FA 15.95T-270 + FK202-4/27
Activation type	Direct	Direct	Direct
Running time per day	10 h	10 h	10 h
Free passage	110 mm	130 mm	78 mm x 105 mm
Volume flow	80 l/s	80 l/s	80 l/s
Delivery head	15.5 m	14.5 m	15.5 m
Motor power	23 kW	35 kW	20.5 kW
Number of poles	4	4	4
	Single-channel impeller	Vortex impeller	Shut SOLID-T impeller
Acquisition costs*	€28,130	€27,170	€28,130
Energy costs per year	€12,592	€19,163	€11,224
Downtime and service costs per year**	€2,000	€500	€1,000
Total costs in five years***	€101,090	€125,485	€89,250

* Gross list prices.

** Estimate based on field test installations at €250 per service callout.

*** Energy costs calculated at a constant rate of 0.15 €/kWh.

Sewage pumps set up dry for 2-pump system for untreated sewage

Cost saving
of approx.
€36,000

Wilo-EMU FA.

Efficient motors are what drives you.

Not only the hydraulics, but the motor is the driving force for your pump when it comes to pumping different fluids with practically no obstructions. Here too, the Wilo-EMU FA adjusts itself precisely to your requirements. You can select between surface-cooled and self-cooling motors, depending on the installation type you require. Moreover, you can choose between several sealing variants depending on the fluid involved. A further boost to operational reliability is within your reach by selecting from various monitoring possibilities.

Seal variants.

Operational reliability, double-protected.

Whenever fluid enters the motor compartment, it will lead to a breakdown. To prevent this, there is a seal housing between the hydraulics and motor which is provided with seals on the motor and pump sides as well as a sealing and leakage chamber.

The requirements on the seal increase with the solid matter content and the proportion of long-fibre constituents in the fluid. As a result, the seals on the motor and pump sides can be made in up to three different ways:

- Standard seal for normal loads. A mechanical seal on the fluid side, a rotary shaft seal on the motor side made of NBR or FPM.
- High-quality seal for high loads provided by two independently rotating mechanical seals.
- High-quality seal for extreme loads provided by two independently rotating mechanical seals made of silicon carbide fitted in a stainless steel cartridge.



The Wilo-EMU FA: Excellently suited to wet and dry well installation



Monitoring devices

- Winding monitoring
- Motor/terminal compartment monitoring
- Sealing chamber control
- Leakage chamber monitoring
- Bearing temperature monitoring

Power efficiently put into practice – with IE3 as well

The higher the efficiency of a motor, the less energy it needs. In addition to the standard motors, you are also able to select highly efficient motors with energy efficiency class IE3 (derived from IEC 60034-30) for your Wilo-EMU FA system. Your increased level of efficiency means you can save up to 5% of your energy costs per year. Thanks to being based on the same design as the standard motors, they can be used with almost all hydraulics, and what is more they are Ex-rated.

Surface-cooled or self-cooling design? It comes down to the installation.

If you are planning a wet well installation in pump chambers, you would be well advised to choose surface-cooled motors. They can be operated immersed in continuous duty and non-immersed in short-time duty. The surface-cooled motors are cooled by the surrounding fluid.

Self-cooling motors are recommended for dry well installation, because they can be used immersed and non-immersed in continuous duty. An internal, active cooling system provides the necessary cooling of the powerful drive. The waste heat is dissipated to the heat exchanger by the coolant. This outputs the waste heat to the fluid.

Monitoring and control.

Everything under control.

You can select various monitoring devices according to the motor, allowing you to keep an optimum eye on the reliable function of the Wilo-EMU FA. This means the winding, the motor compartment, the sealing chamber and also the bearing temperature can be checked. Appropriate switchgears are available in each case for optimum remote control and monitoring.



In this way, the following components are monitored:

Winding temperature

The temperature is registered by bimetallic, PTC or Pt100 sensors. Straightforward temperature limiting or temperature control can be fitted. With the limit, the switch-off must take place as soon as the threshold value is reached. With temperature control, an advance warning can be given if the temperature is low. Switching off is only required at high temperature.

Moisture monitoring in the terminal and motor compartment

Whether fluid ingress or condensation formation is involved, special moisture sensors can detect and report this reliably.

Sealing chamber

The chamber is filled with medicinal white oil. A rod electrode measures the water content and reports if there is a corresponding amount of water in the oil.

Leakage chamber

This chamber is empty as standard. A float switch measures the leakage and reports if there is a corresponding volume flow.

Storage temperature

If the bearings get too hot, the motor will have to be switched off so as to avoid breakdowns. The bearing temperature can be measured with a Pt100 sensor to avoid this happening and to detect bearing damage at an early stage. A relay evaluates the data from the sensor and always displays the current temperature of the motor bearings.



Try & Buy ensures that you make the right decision. Learn more at www.wilo.com/trybuy

Wilo switchgear – as varied as our pumps.

For smooth operation of your system, sewage pumps need to be monitored, and the levels must be optimally recorded and regulated. Wilo offers a diverse portfolio of switchgears with various functions for this purpose. With the switchgears from Wilo, you are able to view the current operating status at any time, control your system to your exact requirements, ensure the operational reliability of your pumps and receive immediate notification in the event of an alarm. For large pumping stations, it is also possible to build individual switchgears precisely to your requirements.



Wilo-Control EC-Lift

- Reliable control and monitoring of one or two pumps, thanks to various monitoring and alarm functions
- Flexible level measurement with level sensor, dynamic pressure bell or float switches
- Increased plant safety when controlling pumps in explosive areas by extending the monitoring functionality in Ex-mode (hardware and software)
- Easy operation with alphanumeric, symbol-based menu and red-button technology
- Operating statuses can be viewed at any time. Greater ease of use via integration with remote monitoring systems via Modbus or optionally via GSM
- Flexible installation. Universal power supply for single-phase current and three-phase current and a wide operating temperature range of $-30\text{ }^{\circ}\text{C}$ to $+60\text{ }^{\circ}\text{C}$.



Wilo-Control SC-Lift

- Reliable control and monitoring of up to four pumps via reliable level measurement with level sensor as well as comprehensive monitoring and alarm functions
- Easy operation with alphanumeric, symbol-based menu and red-button technology
- Transparent indication of operating status thanks to a clear and manageable display
- Efficient and safe control through optional integration with remote systems via Modbus, GSM or GPRS
- Optional version suitable for direct connection (without accessories) of pumps and level sensors within potentially explosive areas



Wilo-Control CC-Lift

- Easy control and monitoring of up to eight pumps via reliable level measurement with level sensor as well as comprehensive networking, monitoring and alarm functions
- Ease of operation thanks to symbol/text-based menu and touch display
- Maximum security thanks to push error messages sent to up to four mobile devices via SMS
- Transparent indication of the operating status thanks to a large touch display
- Additional operational reliability and greater comfort through integration with remote systems via various bus technologies
- Worldwide access to the process data via web-based SCADA interface
- Customer-specific version possible, programmable with custom user and access profiles

The Ceram coating by Wilo.

Effective protection from abrasion and corrosion.

The unique 2-component coating based on a polymer/aluminium oxide composite material offers the best possible protection against aggressive media compared to other coatings. Thanks to its increased resistance to corrosion and abrasion, it effectively prevents wear and chemical corrosion and always ensures optimum functionality and performance. Wilo-Ceram significantly enhances the service life of sewage pumps.



Versatile.

The protective coating permits application even in seawater, brackish water and industrial applications.

Overview of advantages:

- Corrosion-resistant thanks to excellent wet adhesion
- Abrasion-resistant thanks to high proportion of aluminium oxide constituents
- Reliable even in seawater, brackish water and industrial applications
- Can be combined freely with individual Ceram variants for special media



Reliable protection. Exclusively from Wilo.

The Wilo-Ceram coating is exclusively available for pumps and units from Wilo. This gives you a double reassurance. Firstly, knowing that you have selected a tailor-made product. Secondly, being able to use durable technology which, what is more, offers a long service life and reduced downtimes. It is available in four different versions:

Overview of Wilo-Ceram coatings				
	Ceram C0	Ceram C1	Ceram C2	Ceram C3
Technical data				
Protection against	Corrosion	Corrosion	Abrasion	Abrasion
Processing	Can be sprayed	Can be sprayed	Solid	Solid
Coat thickness	0.4 mm	0.8 mm	1.5 mm	3 mm
Use				
Motor housing, external	●	—	—	—
Hydraulics housing, external	●	—	—	—
Hydraulics housing, internal	●	●	●	●
Impeller	●	●	●	—

The Ceram coating from Wilo offers comprehensive protection for the most important components of the Wilo-EMU FA submersible sewage pump.

Resistance for Ceram C0 by Wilo		
Designation	Temperature range	Resistance
Sewage, alkaline (pH 11)	+20 °C – +40 °C	1/1
Sewage, slightly acidic (pH 6)	+20 °C – +40 °C	1/1
Sewage, highly acidic (pH 1)	+20 °C – +40 °C	2/3
Ammonium hydroxide (5%)	+40 °C	3
Decanol (fatty alcohol)	+20 °C – +50 °C	1/1
Ethanol (40%)	+20 °C	1
Ethanol (96%)	+20 °C	3
Ethylene glycol	+20 °C	1
Heating oil, diesel	+20 °C	1
Compressor oil	+20 °C	1
Methyl ethyl ketone (MEK)	+20 °C	3
Caustic soda (5%)	+20 °C – +50 °C	1/2
Sodium chloride solution (10%)	+20 °C	1
Hydrochloric acid (5/10/20%)	+20 °C	2/2/3
Sulphuric acid (10/20%)	+20 °C	2/3
Nitric acid (5%)	+20 °C	3
Toluene	+20 °C	2
Cooling and industrial water	+50 °C	1
Xylene	+20 °C	1

1 = resistant, 2 = 40 day-resistant, 3 = overflow-resistant (immediate cleaning recommended)
For an overall layer thickness of min. 400 µm

Additional stability lists for Ceram C1, C2 and C3 as well as the technical data of the individual Ceram varieties can be found at www.wilo.com/en/watermanagement

Wilo Services.

Our full-service package for you as partners.

With Wilo as your partner, you can not only be sure of choosing high-quality product solutions but also of benefiting from a comprehensive, worry-free package of well thought out services. This means that we support you personally in every project phase, from design and configuration right through commissioning and maintenance. In our seminars we tell you about the very latest technologies and trends. And when it comes to attractive conditions for your projects, we also have just the right package to offer.

In short, Wilo is always by your side. In person and on the spot. With local services in over 60 countries and more than 1,200 Wilo engineers worldwide.

We make the design and selection process simple for you.

We do not want you to select any solution, but the one that exactly meets your requirements. As a result, we work through your requirements with you before the purchase and, based on this, we prepare the individual product solution that is most economical for you.

Pre-sales services for your tailor-made choice:

- Local support
- Design support
- Product selection
- Selection programmes
- Digital flow simulations
- Flow calculation
- Pipe calculation
- Installation drawings
- Documentation

“Services that provide comprehensive and reliable support.

That’s what we call Pioneering for You.”



For more information, go to
www.wilo.com/en/watermanagement



You can't go wrong with Wilo.

When you have made your choice we provide you with thorough advice on your investment. What is more, we don't just deliver your solution, we continue to support you – from certification right through to commissioning. For example, qualified plant engineers with years of experience will carry out an extensive test and training phase with our pumps.

Sales services that really work for you.

- Certification
- Acceptance testing at the plant
- Commissioning
- Start-up

→ Wilo Financial Services

We help you with the financial implementation of your projects, and we will gladly create a quotation tailored for your investment.

→ Try & Buy

Try & Buy lets you play safe with your investments. Choose a no-risk trial for up to six months to convince yourself of the quality of Wilo's products.



We are there for you. Even after the purchase.

Our tailor-made service solutions cover the entire life cycle of your Wilo products – even after the purchase. That is why we have professional service engineers available for you locally and globally so that we can supply spare parts quickly and reliably at any time, and why we provide targeted training courses among other things to enhance your expertise. And we continually strive to improve our services.

After-sales services with real added value for you.

- Customised, reliable maintenance concepts
- Rapid repair service
- Fast spare parts solutions
- Efficiency check
- Specific training courses

→ WiloCare

Our service offer for guaranteed operational reliability and cost certainty. Monthly reports keep you up to date on how your system is doing: system status, energy consumption, possible optimisations and pending maintenance intervals. Wilo can offer you individually tailored services in various packages at a fixed monthly price. These allow you to check how reliable your processes are at any time – both in terms of technology and costs.





WILO SE
Nortkirchenstraße 100
D-44263 Dortmund
Germany
T +49 231 4102-0
F +49 231 4102-7363
wilo@wilo.com
www.wilo.com

Pioneering for You

More contact details at www.wilo.com