

# AJ AXIAL FLOW DIMENSIONAL INFORMATION

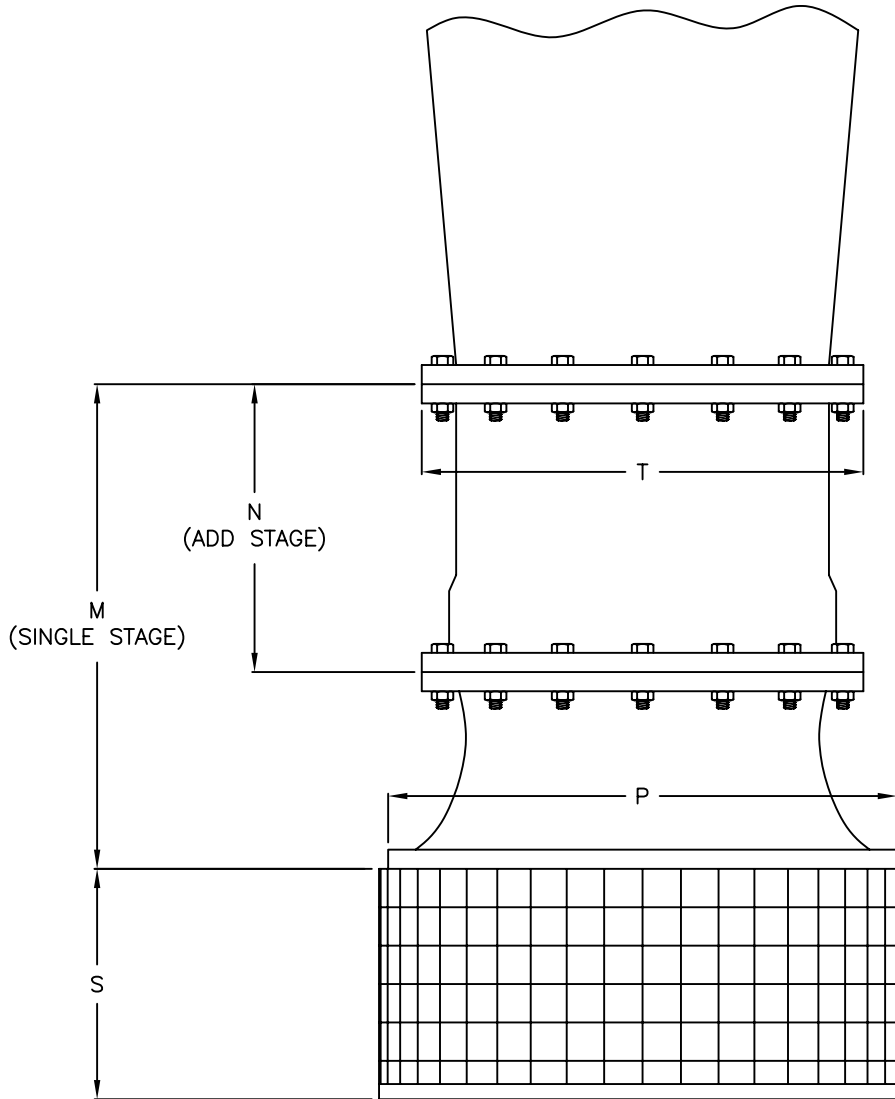

MODEL	M	N	P	S	T	1ST STAGE WEIGHT	ADD'L STAGE WEIGHT	AVAILABLE COL.		MIN. TRIM BELL
								FLANGED	THREADED	
8"	12.125	7.500	13.250	6.000	11.500	112 LBS	64 LBS	8"	8",10"	11.500
10"	15.313	9.438	16.750	7.000	13.375	176 LBS	100 LBS	10"	10",12"	13.375
12"	19.188	11.750	20.500	8.000	16.375	312 LBS	173 LBS	12"	12",14"	16.375
14"	22.250	13.750	23.500	9.000	18.625	424 LBS	250 LBS	14"	14"	18.625
16"	25.750	15.750	26.625	11.000	20.750	595 LBS	355 LBS	16"	N/A	20.375
20"	31.875	19.375	33.500	12.000	25.375	965 LBS	610 LBS	20"	N/A	25.375
24"	38.500	23.500	42.000	14.500	30.000	1610 LBS	975 LBS	24"	N/A	30.000
30"	48.250	29.500	50.000	18.000	36.000	2600 LBS	1510 LBS	30"	N/A	36.000
36"	58.000	35.500	60.000	20.000	42.625	4420 LBS	2670 LBS	36"	N/A	42.625
42"	67.500	41.500	72.000	20.000	49.250	6200 LBS	3760 LBS	42"	N/A	62.000
48"	76.500	47.000	80.000	24.000	56.000	9000 LBS	5400 LBS	48"	N/A	70.000
54"	86.500	53.250	96.000	26.000	64.000	13600 LBS	8600 LBS	54"	N/A	RTF
60"	96.500	59.000	100.000	28.000	71.000	18400 LBS	11000 LBS	60"	N/A	RTF
72"	116.000	71.000	120.000	32.000	85.000	32000 LBS	20400 LBS	72"	N/A	RTF