

# Submittal Data Sheet

## Wilo-Helix EXCEL Complete- NSF 61/372 Pressure Boosting System



### Helix EXCEL Complete V50-02-1/1.5/VCE

	Project:							
	Engineer:							
	Contractor:							
	Submitted By:				Date:			
	Approved By:				Date:			
Tag #	Model #	Flow	BOOST PSI	Min. Inlet PSI	HP/pump	Phase	Voltage	RPM
	Helix EXCEL Complete V50-02-1/1.5/460				1.5			3600

### Article Number: 3313899

Helix EXCEL Complete V50-02-1/1.5/460

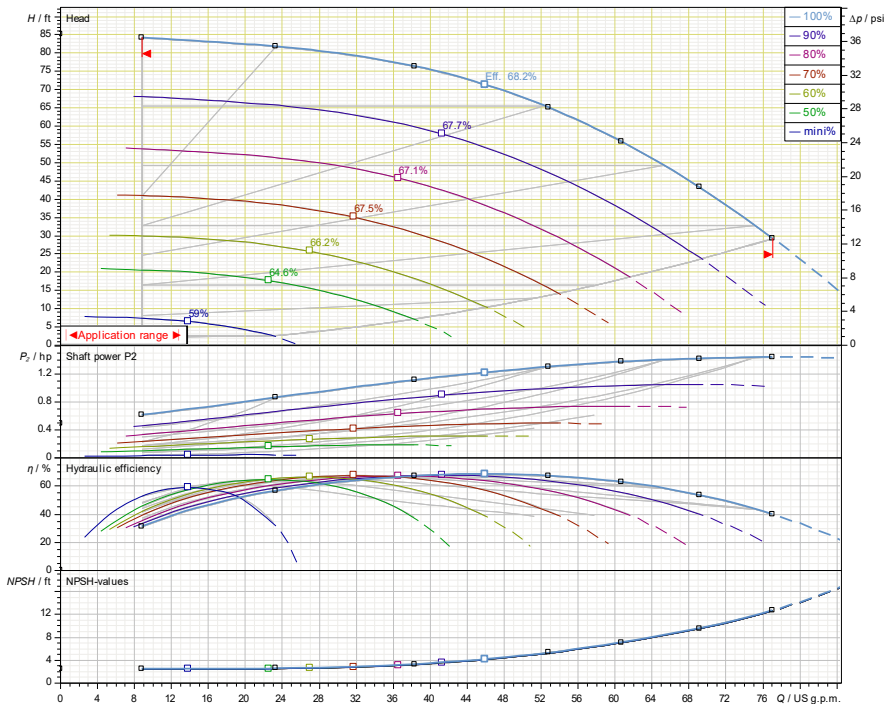

### Applications

- Water Supply
- Pressure Boosting
- Agriculture
- Cooling Circuits
- Washing / Sprinkling Systems
- Condensate Return

### Materials of Construction

Pump Volute	AISI304 stainless steel with ANSI flanges
Impeller	3D Laser welded AISI 304 Stainless Steel
Shaft	AISI304, AISI318 LN, or AISI431 Stainless Steel
Elastomers	EPDM
Isolation Valves	Cast Iron with 316 Stainless Steel Interl Disc and Stem Butterfly Valve
Suction/Discharge Manifolds	AISI304 Stainless Steel with Flanged System Connections
Check Valves	Wafer Style, 316 Stainless Steel internals, Non-slam, Plunger-type with EPDM seal/ Cast Iron Body
Mechanical Seal	Cartridge Seal: Sleeve AISI316L / Spring Clips AISI304
Pressure Transducers	316 Stainless Steel
Pressure Guages	304 Stainless Steel Housing with 316 Stainless Steel wetted parts
System base	Steel (S235JR)
Vibration Isolators	Neoprene, Height Adjustable

### Technical Data – Operational Ranges

Liquid Temp Range	-4°F to +180°F (Min. 32 °F for Domestic Water)
Ambient Temp Range	+32°F to +104 °F
Max Inlet Pressure	145 PSI
Max System Pressure	232 PSI/363 PSI

### Technical Data – Panel

Power Supply	460v~3
Enclosure	NEMA 12 (3R Available Upon Request)
Standard	Meets UL 508A

### Technical Data – Power Head

User Interface	3" Diagonal LCD with Green Button selection
Supply Voltage	24VDC
Number of Analog Inputs	2 (1 External set value/1 Pressure sensor)
Number of Analog Outputs	0
Number of Digital Inputs	1 (External On/Off)
Number of Digital Outputs	0
Optional Communications	Gateways for Modbus, BacNET, and LonWorks
Dip Switches	4

### Motor Data

Power Supply	460V~3
Motor Enclosure	Totally Enclosed Fan Cooled (TEFC)
Motor Efficiency	IEC Premium Efficiency (IE5) – Electronically Commutated Motor (EC Motor with Powerhead control)
Enclosure Construction	Cast Iron
Motor Protection Index	IP55
Insulation Class	F

Approval Stamp

# Submittal Data Sheet

Wilo-Helix EXCEL Complete- NSF 61/372 Pressure Boosting System



## Helix EXCEL Complete V50-02-1/1.5/VCE

460 V~3

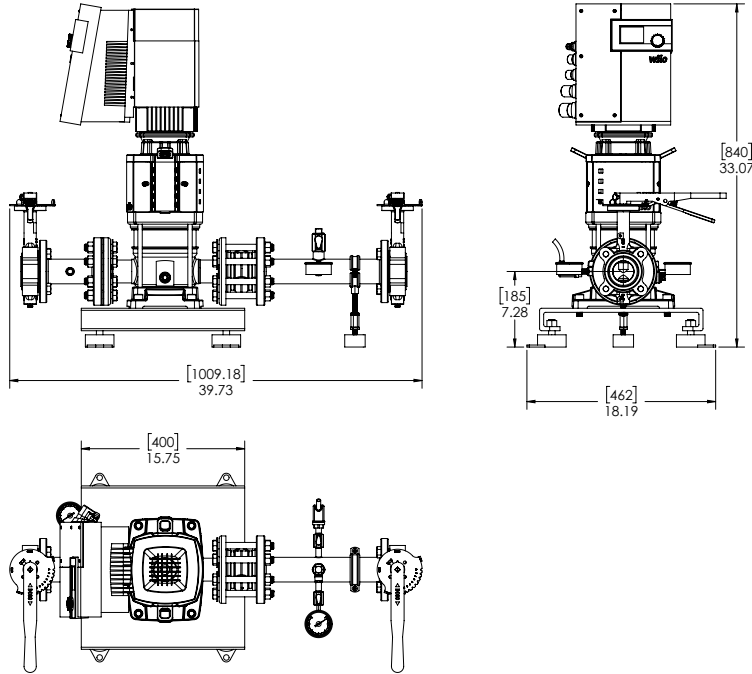

3313899

Special Note: All weights and dimensions are approximate and should not be used as exact rough-in dimensions

### Dimensions and Weights

Model	Voltage (V)	H (in)	W (in)	L (in)	Dimensions-inches				Hydrnumatic Tank Valve on Manifold (Plugged)	Individual Pump Weight	Package Weight
					System Header Size	Suction / Discharge Pump Size (300 Class ANSI)	Gauge Tap Size	Transducer Tap Size		Pump Weight (lbs)	Package Weight (lbs)
Helix EXCEL Complete V50-02-1/1.5/460	460 V	33	18-1/4	39-3/4	2" 150# ANSI	2"	1/4" FNPT	1/4" FNPT	3/4" MNPT x 3/4" FNPT	110	170

### EC Motor Data (Single Motor Operation)

Model	P2		Phase	Voltage	FLA (per pump)	Efficiency	Pmax
	(HP)	(KW)	(~)	(V)	(A)	ηm 100%	(PSI)
Helix EXCEL Complete V50-02-1/1.5/460	1.5	1.5	3	460 (±10%)	1.76	92	232

# Submittal Data Sheet

Wilo-Helix EXCEL Complete- NSF 61/372 Pressure Boosting System



## Helix EXCEL Complete V50-04-1/3/VCE

	Project:							
	Engineer:							
	Contractor:							
	Submitted By:				Date:			
	Approved By:				Date:			
Tag #	Model #	Flow	BOOST PSI	Min. Inlet PSI	HP/Pump	Phase	Voltage	RPM
	Helix EXCEL Complete V50-04-1/3/460				3			3600

### Article Number: 3313900

Helix EXCEL Complete V50-04-1/3/460

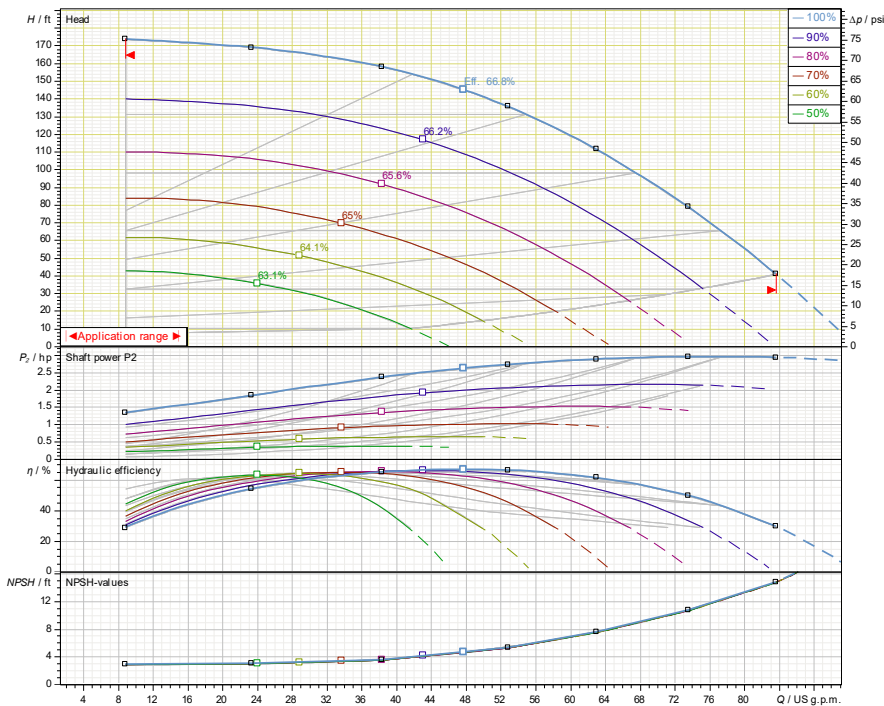

### Applications

- Water Supply
- Pressure Boosting
- Agriculture
- Cooling Circuits
- Washing / Sprinkling Systems
- Condensate Return

### Materials of Construction

Pump Volute	AISI304 stainless steel with ANSI flanges
Impeller	3D Laser welded AISI 304 Stainless Steel
Shaft	AISI304, AISI318 LN, or AISI431 Stainless Steel
Elastomers	EPDM
Isolation Valves	Cast Iron with 316 Stainless Steel Interl Disc and Stem Butterfly Valve
Suction/Discharge Manifolds	AISI304 Stainless Steel with Flanged System Connections
Check Valves	Wafer Style, 316 Stainless Steel internals, Non-slam, Plunger-type with EPDM seal/ Cast Iron Body
Mechanical Seal	Cartridge Seal: Sleeve AISI316L / Spring Clips AISI304
Pressure Transducers	316 Stainless Steel
Pressure Guages	304 Stainless Steel Housing with 316 Stainless Steel wetted parts
System base	Steel (S235JR)
Vibration Isolators	Neoprene, Height Adjustable

### Technical Data – Operational Ranges

Liquid Temp Range	-4°F to +180°F (Min. 32 °F for Domestic Water)
Ambient Temp Range	+32°F to +104 °F
Max Inlet Pressure	145 PSI
Max System Pressure	232 PSI/363 PSI

### Technical Data – Panel

Power Supply	460V~3
Enclosure	NEMA 12 (3R Available Upon Request)
Standard	Meets UL 508A

### Technical Data – Power Head

User Interface	3" Diagonal LCD with Green Button selection
Supply Voltage	24VDC
Number of Analog Inputs	2 (1 External set value/1 Pressure sensor)
Number of Analog Outputs	0
Number of Digital Inputs	1 (External On/Off)
Number of Digital Outputs	0
Optional Communications	Gateways for Modbus, BacNET, and LonWorks
Dip Switches	4

### Motor Data

Power Supply	460V~3
Motor Enclosure	Totally Enclosed Fan Cooled (TEFC)
Motor Efficiency	IEC Premium Efficiency (IE5) – Electronically Commutated Motor (EC Motor with Powerhead control)
Enclosure Construction	Cast Iron
Motor Protection Index	IP55
Insulation Class	F

Approval Stamp

# Submittal Data Sheet

Wilo-Helix EXCEL Complete- NSF 61/372 Pressure Boosting System



## Helix EXCEL Complete V50-04-1/3/VCE

460 V~3

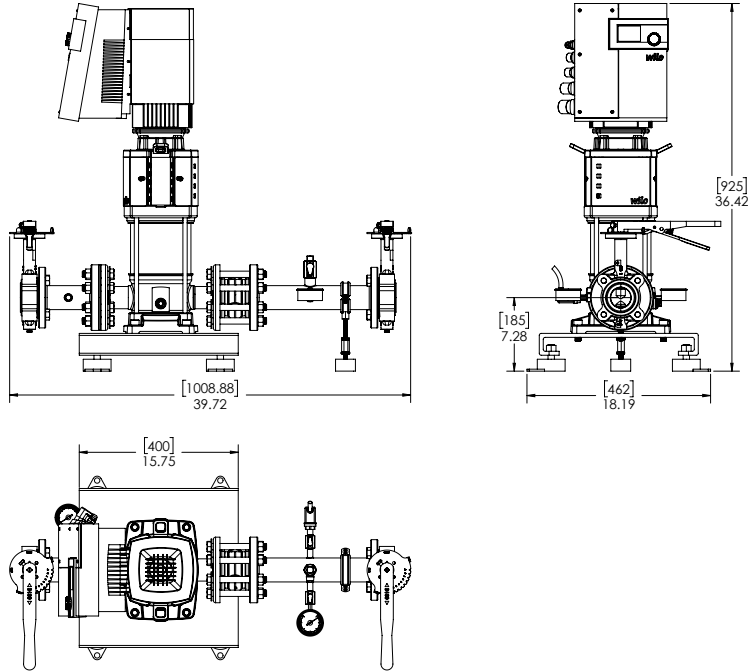

3313900

Special Note: All weights and dimensions are approximate and should not be used as exact rough-in dimensions

### Dimensions and Weights

Model	Voltage (V)	H (in)	W (in)	L (in)	Dimensions-inches				Hydronumatic Tank Valve on Manifold (Plugged)	Individual Pump Weight	Package Weight
					System Header Size	Suction / Discharge Pump Size (300 Class ANSI)	Gauge Tap Size	Transducer Tap Size		Pump Weight (lbs)	Package Weight (lbs)
Helix EXCEL Complete V50-04-1/3/460	460 V	36-1/2	18-1/4	39-3/4	2" 150# ANSI	2"	1/4" FNPT	1/4" FNPT	3/4" MNPT x 3/4" FNPT	119	180

### EC Motor Data (Single Motor Operation)

Model	P2		Phase (-)	Voltage (V)	FLA (per pump) (A)	Efficiency $\eta_{m 100\%}$	Pmax (PSI)
	(HP)	(KW)					
Helix EXCEL Complete V50-04-1/3/460	3	2.2	3	460 ( $\pm 10\%$ )	4.4	93	232

# Submittal Data Sheet

Wilo-Helix EXCEL Complete- NSF 61/372 Pressure Boosting System



## Helix EXCEL Complete V50-05-1/4.3/VCE

	Project:							
	Engineer:							
	Contractor:							
	Submitted By:				Date:			
	Approved By:				Date:			
Tag #	Model #	Flow	BOOST PSI	Min. Inlet PSI	HP/pump	Phase	Voltage	RPM
	Helix EXCEL Complete V50-05-1/4.3/460				4.3			3600

### Article Number: 3313901

Helix EXCEL Complete V50-05-1/4.3/460

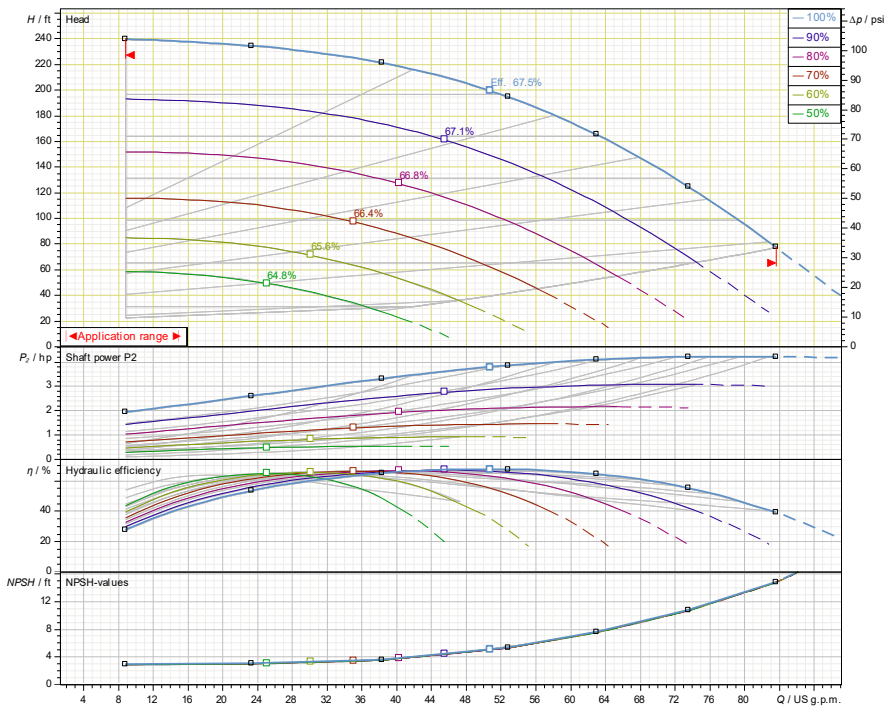

### Applications

- Water Supply
- Pressure Boosting
- Agriculture
- Cooling Circuits
- Washing / Sprinkling Systems
- Condensate Return

### Materials of Construction

Pump Volute	AISI304 stainless steel with ANSI flanges
Impeller	3D Laser welded AISI 304 Stainless Steel
Shaft	AISI304, AISI318 LN, or AISI431 Stainless Steel
Elastomers	EPDM
Isolation Valves	Cast Iron with 316 Stainless Steel Interl Disc and Stem Butterfly Valve
Suction/Discharge Manifolds	AISI304 Stainless Steel with Flanged System Connections
Check Valves	Wafer Style, 316 Stainless Steel internals, Non-slam, Plunger-type with EPDM seal/ Cast Iron Body
Mechanical Seal	Cartridge Seal: Sleeve AISI316L / Spring Clips AISI304
Pressure Transducers	316 Stainless Steel
Pressure Guages	304 Stainless Steel Housing with 316 Stainless Steel wetted parts
System base	Steel (S235JR)
Vibration Isolators	Neoprene, Height Adjustable

### Technical Data – Operational Ranges

Liquid Temp Range	-4°F to +180°F (Min. 32 °F for Domestic Water)
Ambient Temp Range	+32°F to +104 °F
Max Inlet Pressure	145 PSI
Max System Pressure	232 PSI/363 PSI

### Technical Data – Panel

Power Supply	460V~3
Enclosure	NEMA 12 (3R Available Upon Request)
Standard	Meets UL 508A

### Technical Data – Power Head

User Interface	3" Diagonal LCD with Green Button selection
Supply Voltage	24VDC
Number of Analog Inputs	2 (1 External set value/1 Pressure sensor)
Number of Analog Outputs	0
Number of Digital Inputs	1 (External On/Off)
Number of Digital Outputs	0
Optional Communications	Gateways for Modbus, BacNET, and LonWorks
Dip Switches	4

### Motor Data

Power Supply	460V~3
Motor Enclosure	Totally Enclosed Fan Cooled (TEFC)
Motor Efficiency	IEC Premium Efficiency (IE5) – Electronically Commutated Motor (EC Motor with Powerhead control)
Enclosure Construction	Cast Iron
Motor Protection Index	IP55
Insulation Class	F

Approval Stamp

# Submittal Data Sheet

Wilo-Helix EXCEL Complete- NSF 61/372 Pressure Boosting System



## Helix EXCEL Complete V50-05-1/4.3/VCE

460 V~3

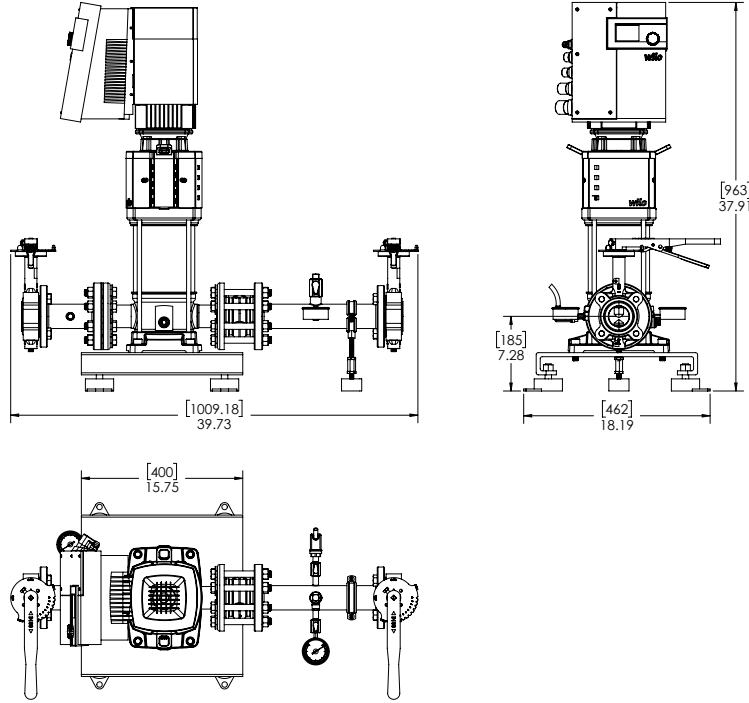

3313901

Special Note: All weights and dimensions are approximate and should not be used as exact rough-in dimensions

### Dimensions and Weights

Model	Voltage (V)	H (in)	W (in)	L (in)	Dimensions-inches				Hydronumatic Tank Valve on Manifold (Plugged)	Individual Pump Weight	Package Weight
					System Header Size	Suction / Discharge Pump Size (300 Class ANSI)	Gauge Tap Size	Transducer Tap Size		Pump Weight (lbs)	Package Weight (lbs)
Helix EXCEL Complete V50-05-1/4.3/460	460 V	37-7/8	18-1/4	39-3/4	2" 150# ANSI	2"	1/4" FNPT	1/4" FNPT	3/4" MNPT x 3/4" FNPT	121	181

### EC Motor Data (Single Motor Operation)

Model	P2		Phase (-)	Voltage (V)	FLA (per pump) (A)	Efficiency η <sub>m</sub> 100%	P <sub>max</sub> (PSI)
	(HP)	(KW)					
Helix EXCEL Complete V50-05-1/4.3/460	4.3	3.2	3	460 (±10%)	6	93	232

# Submittal Data Sheet

Wilo-Helix EXCEL Complete- NSF 61/372 Pressure Boosting System



## Helix EXCEL Complete V50-07-1/5.6/VCE



Project:	
Engineer:	
Contractor:	
Submitted By:	Date:
Approved By:	Date:

Tag #	Model #	Flow	BOOST PSI	Min. Inlet PSI	HP/Pump	Phase	Voltage	RPM
	Helix EXCEL Complete V50-07-1/5.6/460				5.6			3600

### Article Number: 3313902

Helix EXCEL Complete V50-07-1/5.6/460

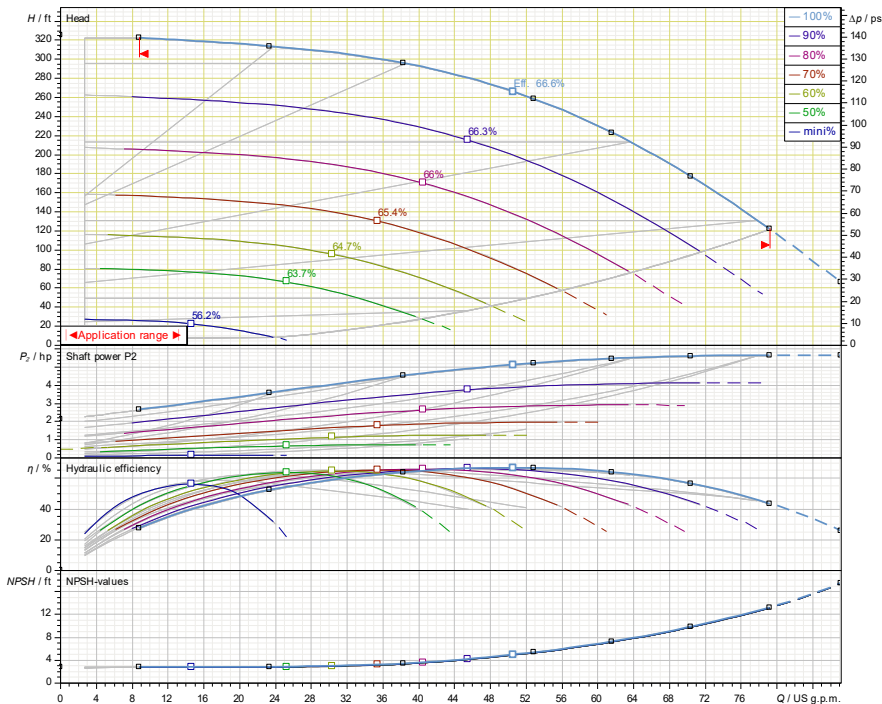

### Applications

- Water Supply
- Pressure Boosting
- Agriculture
- Cooling Circuits
- Washing / Sprinkling Systems
- Condensate Return

### Materials of Construction

Pump Volute	AISI304 stainless steel with ANSI flanges
Impeller	3D Laser welded AISI 304 Stainless Steel
Shaft	AISI304, AISI318 LN, or AISI431 Stainless Steel
Elastomers	EPDM
Isolation Valves	Cast Iron with 316 Stainless Steel Interl Disc and Stem Butterfly Valve
Suction/Discharge Manifolds	AISI304 Stainless Steel with Flanged System Connections
Check Valves	Wafer Style, 316 Stainless Steel internals, Non-slam, Plunger-type with EPDM seal/ Cast Iron Body
Mechanical Seal	Cartridge Seal: Sleeve AISI316L / Spring Clips AISI304
Pressure Transducers	316 Stainless Steel
Pressure Guages	304 Stainless Steel Housing with 316 Stainless Steel wetted parts
System base	Steel (S235JR)
Vibration Isolators	Neoprene, Height Adjustable

### Technical Data – Operational Ranges

Liquid Temp Range	-4°F to +180°F (Min. 32 °F for Domestic Water)
Ambient Temp Range	+32°F to +104 °F
Max Inlet Pressure	145 PSI
Max System Pressure	232 PSI/363 PSI

### Technical Data – Panel

Power Supply	460v~3
Enclosure	NEMA 12 (3R Available Upon Request)
Standard	Meets UL 508A

### Technical Data – Power Head

User Interface	3" Diagonal LCD with Green Button selection
Supply Voltage	24VDC
Number of Analog Inputs	2 (1 External set value/1 Pressure sensor)
Number of Analog Outputs	0
Number of Digital Inputs	1 (External On/Off)
Number of Digital Outputs	0
Optional Communications	Gateways for Modbus, BacNET, and LonWorks
Dip Switches	4

### Motor Data

Power Supply	460V~3
Motor Enclosure	Totally Enclosed Fan Cooled (TEFC)
Motor Efficiency	IEC Premium Efficiency (IE5) – Electronically Commutated Motor (EC Motor with Powerhead control)
Enclosure Construction	Cast Iron
Motor Protection Index	IP55
Insulation Class	F

Approval Stamp

# Submittal Data Sheet

Wilo-Helix EXCEL Complete- NSF 61/372 Pressure Boosting System



## Helix EXCEL Complete V50-07-1/5.6/VCE

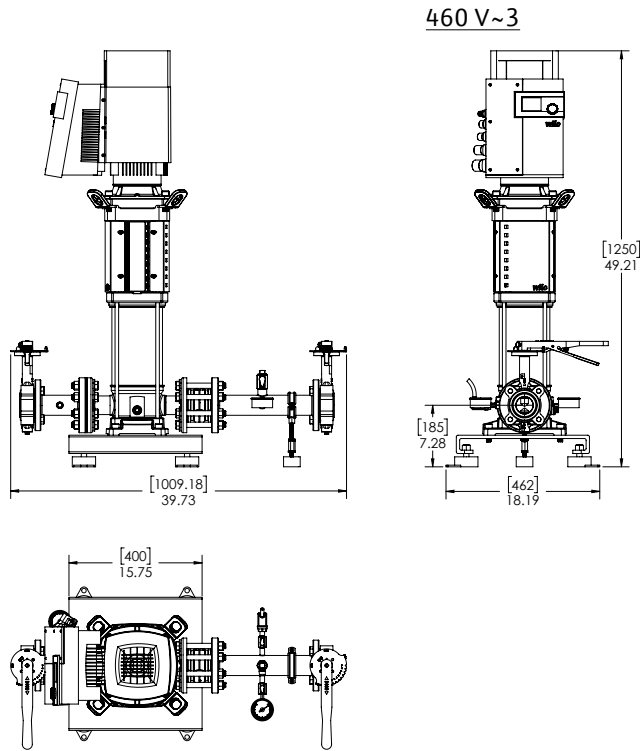

3313902

Special Note: All weights and dimensions are approximate and should not be used as exact rough-in dimensions

### Dimensions and Weights

Model	Voltage (V)	H (in)	W (in)	L (in)	Dimensions-inches				Hydronumatic Tank Valve on Manifold (Plugged)	Individual Pump Weight Pump Weight (lbs)	Package Weight (lbs)
					System Header Size	Suction / Discharge Pump Size (300 Class ANSI)	Gauge Tap Size	Transducer Tap Size			
Helix EXCEL Complete V50-07-1/5.6/460	460 V	49-1/4	18-1/4	39-3/4	2" 150# ANSI	2"	1/4" FNPT	1/4" FNPT	3/4" MNPT x 3/4" FNPT	154	214

### EC Motor Data (Single Motor Operation)

Model	P2		Phase (-)	Voltage (V)	FLA (per pump) (A)	Efficiency η <sub>m</sub> 100%	P <sub>max</sub> (PSI)
	(HP)	(KW)					
Helix EXCEL Complete V50-07-1/5.6/460	5.6	4.2	3	460 (±10%)	6.5	95.8	232



# Submittal Data Sheet

Wilo-Helix EXCEL Complete- NSF 61/372 Pressure Boosting System



## Helix EXCEL Complete V50-09-1/7.4/VCE

	Project:							
	Engineer:							
	Contractor:							
	Submitted By:				Date:			
	Approved By:				Date:			
Tag #	Model #	Flow	BOOST PSI	Min. Inlet PSI	HP/Pump	Phase	Voltage	RPM
	Helix EXCEL Complete V50-09-1/7.4/460				7.4			3600

### Article Number: 3313903

Helix EXCEL Complete V50-09-1/7.4/460

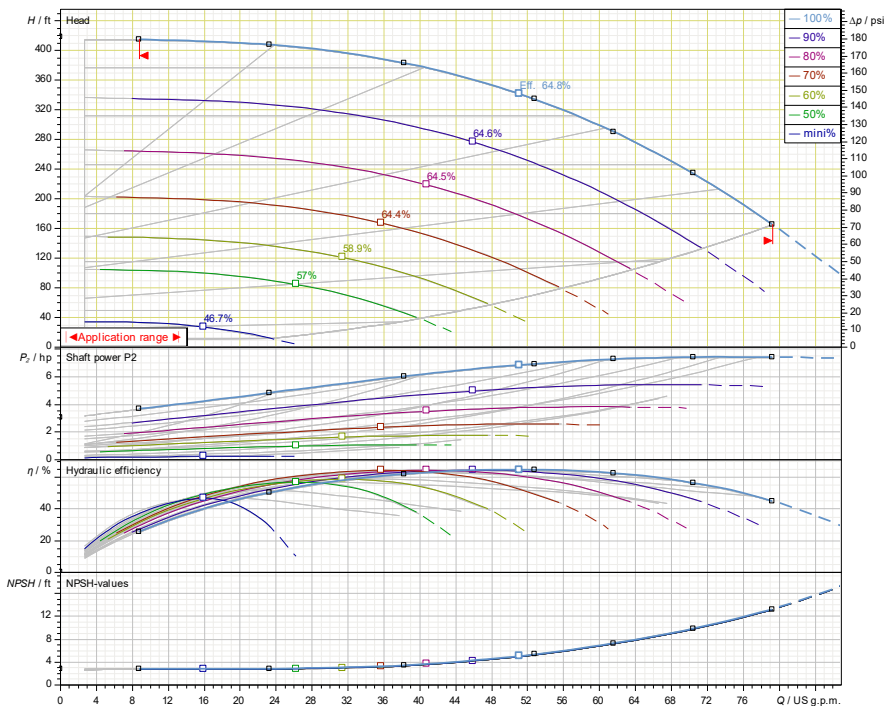

### Applications

- Water Supply
- Pressure Boosting
- Agriculture
- Cooling Circuits
- Washing / Sprinkling Systems
- Condensate Return

### Materials of Construction

Pump Volute	AISI304 stainless steel with ANSI flanges
Impeller	3D Laser welded AISI 304 Stainless Steel
Shaft	AISI304, AISI318 LN, or AISI431 Stainless Steel
Elastomers	EPDM
Isolation Valves	Cast Iron with 316 Stainless Steel Interl Disc and Stem Butterfly Valve
Suction/Discharge Manifolds	AISI304 Stainless Steel with Flanged System Connections
Check Valves	Wafer Style, 316 Stainless Steel internals, Non-slam, Plunger-type with EPDM seal/ Cast Iron Body
Mechanical Seal	Cartridge Seal: Sleeve AISI316L / Spring Clips AISI304
Pressure Transducers	316 Stainless Steel
Pressure Guages	304 Stainless Steel Housing with 316 Stainless Steel wetted parts
System base	Steel (S235JR)
Vibration Isolators	Neoprene, Height Adjustable

### Technical Data – Operational Ranges

Liquid Temp Range	-4°F to +180°F (Min. 32 °F for Domestic Water)
Ambient Temp Range	+32°F to +104 °F
Max Inlet Pressure	145 PSI
Max System Pressure	232 PSI/363 PSI

### Technical Data – Panel

Power Supply	460V~3
Enclosure	NEMA 12 (3R Available Upon Request)
Standard	Meets UL 508A

### Technical Data – Power Head

User Interface	3" Diagonal LCD with Green Button selection
Supply Voltage	24VDC
Number of Analog Inputs	2 (1 External set value/1 Pressure sensor)
Number of Analog Outputs	0
Number of Digital Inputs	1 (External On/Off)
Number of Digital Outputs	0
Optional Communications	Gateways for Modbus, BacNET, and LonWorks
Dip Switches	4

### Motor Data

Power Supply	460V~3
Motor Enclosure	Totally Enclosed Fan Cooled (TEFC)
Motor Efficiency	IEC Premium Efficiency (IE5) – Electronically Commutated Motor (EC Motor with Powerhead control)
Enclosure Construction	Cast Iron
Motor Protection Index	IP55
Insulation Class	F

Approval Stamp

# Submittal Data Sheet

Wilo-Helix EXCEL Complete- NSF 61/372 Pressure Boosting System



## Helix EXCEL Complete V50-09-1/7.4/VCE

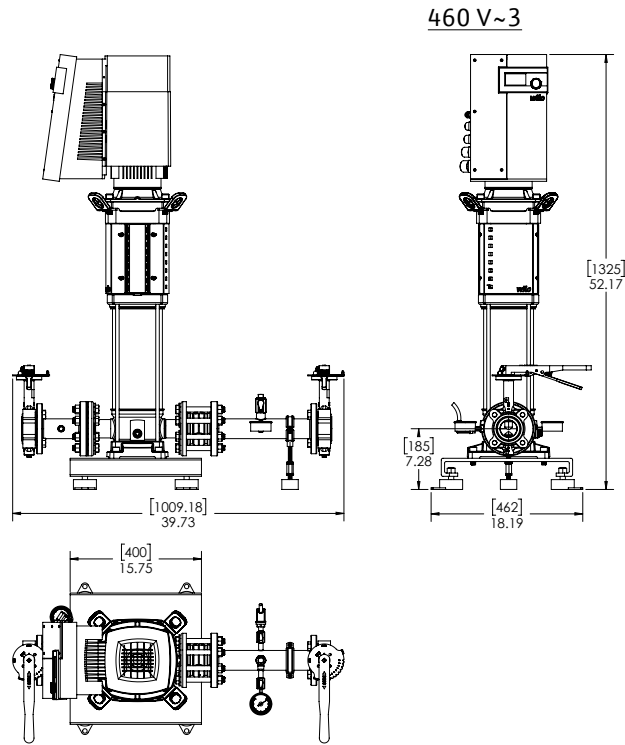

3313903

Special Note: All weights and dimensions are approximate and should not be used as exact rough-in dimensions

### Dimensions and Weights

Model	Voltage (V)	H (in)	W (in)	L (in)	Dimensions-inches				Hydronumatic Tank Valve on Manifold (Plugged)	Individual Pump Weight	Package Weight
					System Header Size	Suction / Discharge Pump Size (300 Class ANSI)	Gauge Tap Size	Transducer Tap Size		Pump Weight (lbs)	Package Weight (lbs)
Helix EXCEL Complete V50-09-1/7.4/460	460 V	52-1/4	18-1/4	39-3/4	2" 150# ANSI	2"	1/4" FNPT	1/4" FNPT	3/4" MNPT x 3/4" FNPT	190	250

### EC Motor Data (Single Motor Operation)

Model	P2		Phase (-)	Voltage (V)	FLA (per pump) (A)	Efficiency $\eta_{100\%}$	Pmax (PSI)
	(HP)	(KW)					
Helix EXCEL Complete V50-09-1/7.4/460	7.4	5.5	3	460 ( $\pm 10\%$ )	8.2	95.8	232

# Submittal Data Sheet

Wilo-Helix EXCEL Complete- NSF 61/372 Pressure Boosting System



## Helix EXCEL Complete V50-10-1/8.7/VCE

	Project:							
	Engineer:							
	Contractor:							
	Submitted By:				Date:			
	Approved By:				Date:			
Tag #	Model #	Flow	BOOST PSI	Min. Inlet PSI	HP/pump	Phase	Voltage	RPM
	Helix EXCEL Complete V50-10-1/8.7/460				8.7			3600

### Article Number: 3313904

Helix EXCEL Complete V50-10-1/8.7/460

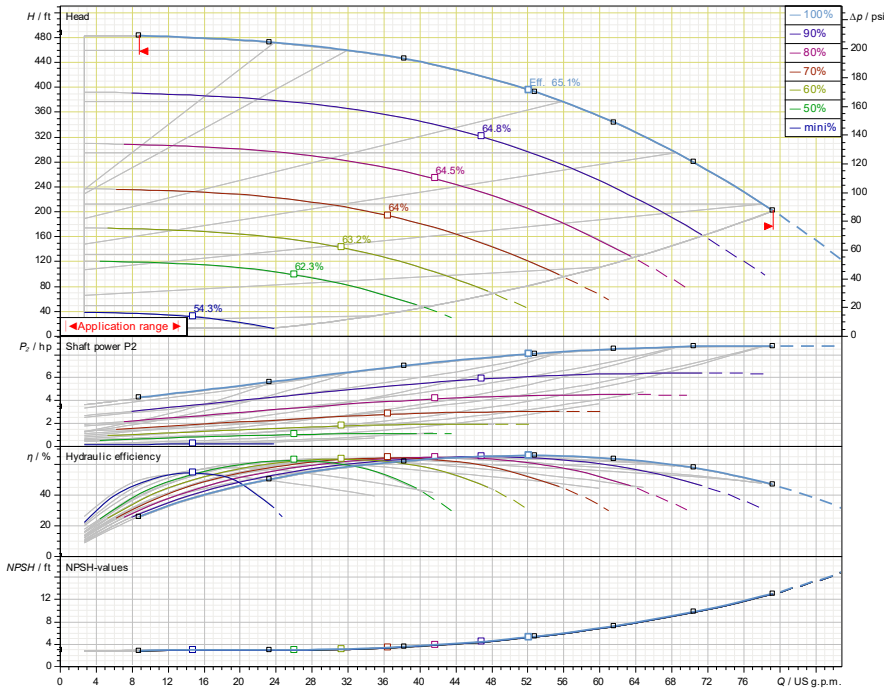

### Applications

- Water Supply
- Pressure Boosting
- Agriculture
- Cooling Circuits
- Washing / Sprinkling Systems
- Condensate Return

### Materials of Construction

Pump Volute	AISI304 stainless steel with ANSI flanges
Impeller	3D Laser welded AISI 304 Stainless Steel
Shaft	AISI304, AISI318 LN, or AISI431 Stainless Steel
Elastomers	EPDM
Isolation Valves	Cast Iron with 316 Stainless Steel Interl Disc and Stem Butterfly Valve
Suction/Discharge Manifolds	AISI304 Stainless Steel with Flanged System Connections
Check Valves	Wafer Style, 316 Stainless Steel internals, Non-slam, Plunger-type with EPDM seal/ Cast Iron Body
Mechanical Seal	Cartridge Seal: Sleeve AISI316L / Spring Clips AISI304
Pressure Transducers	316 Stainless Steel
Pressure Guages	304 Stainless Steel Housing with 316 Stainless Steel wetted parts
System base	Steel (S235JR)
Vibration Isolators	Neoprene, Height Adjustable

### Technical Data – Operational Ranges

Liquid Temp Range	-4°F to +180°F (Min. 32 °F for Domestic Water)
Ambient Temp Range	+32°F to +104 °F
Max Inlet Pressure	145 PSI
Max System Pressure	232 PSI/363 PSI

### Technical Data – Panel

Power Supply	460V~3
Enclosure	NEMA 12 (3R Available Upon Request)
Standard	Meets UL 508A

### Technical Data – Power Head

User Interface	3" Diagonal LCD with Green Button selection
Supply Voltage	24VDC
Number of Analog Inputs	2 (1 External set value/1 Pressure sensor)
Number of Analog Outputs	0
Number of Digital Inputs	1 (External On/Off)
Number of Digital Outputs	0
Optional Communications	Gateways for Modbus, BacNET, and LonWorks
Dip Switches	4

### Motor Data

Power Supply	460V~3
Motor Enclosure	Totally Enclosed Fan Cooled (TEFC)
Motor Efficiency	IEC Premium Efficiency (IE5) – Electronically Commutated Motor (EC Motor with Powerhead control)
Enclosure Construction	Cast Iron
Motor Protection Index	IP55
Insulation Class	F

Approval Stamp

# Submittal Data Sheet

Wilo-Helix EXCEL Complete- NSF 61/372 Pressure Boosting System



## Helix EXCEL Complete V50-10-1/8.7/VCE

460 V~3

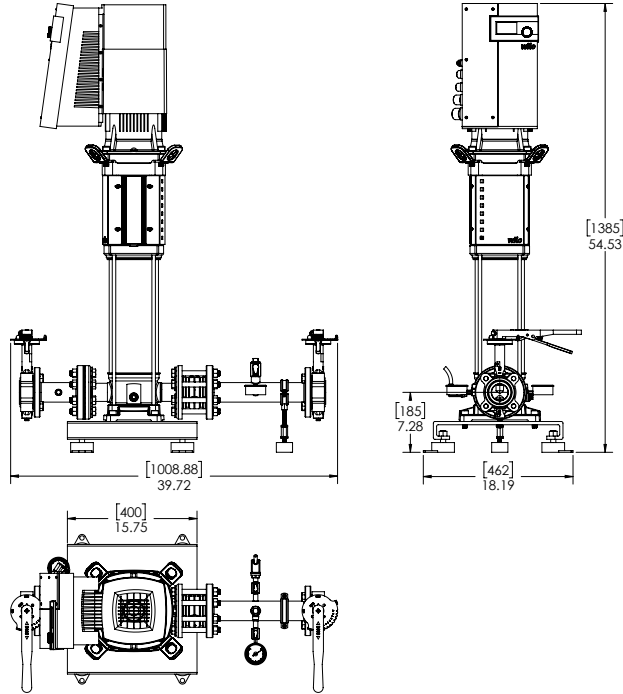

3313904

Special Note: All weights and dimensions are approximate and should not be used as exact rough-in dimensions

### Dimensions and Weights

Model	Voltage (V)	H (in)	W (in)	L (in)	Dimensions-inches				Hydronumatic Tank Valve on Manifold (Plugged)	Individual Pump Weight	Package Weight
					System Header Size	Suction / Discharge Pump Size (300 Class ANSI)	Gauge Tap Size	Transducer Tap Size		Pump Weight (lbs)	Package Weight (lbs)
Helix EXCEL Complete V50-10-1/8.7/460	460 V	54-1/2	18-1/4	39-3/4	2" 150# ANSI	2"	1/4" FNPT	1/4" FNPT	3/4" MNPT x 3/4" FNPT	203	263

### EC Motor Data (Single Motor Operation)

Model	P2		Phase (-)	Voltage (V)	FLA (per pump) (A)	Efficiency η <sub>m</sub> 100%	P <sub>max</sub> (PSI)
	(HP)	(KW)					
Helix EXCEL Complete V50-10-1/8.7/460	8.7	6.5	3	460 (±10%)	9.7	96.5	232