

Submittal Data Sheet

Wilo-Helix EXCEL Complete- NSF 61/372 Pressure Boosting System



Helix EXCEL Complete V270-01/5.7/460



Project:	
Engineer:	
Contractor:	
Submitted By:	Date:
Approved By:	Date:

Tag #	Model #	Flow	BOOST PSI	Min. Inlet PSI	HP/Pump	Phase	Voltage	RPM
	Helix EXCEL Complete V270-01/5.7/460				5.7			3600

Article Number: 2700964

Helix_EXCEL_Complete_V270-01_5.7_460V

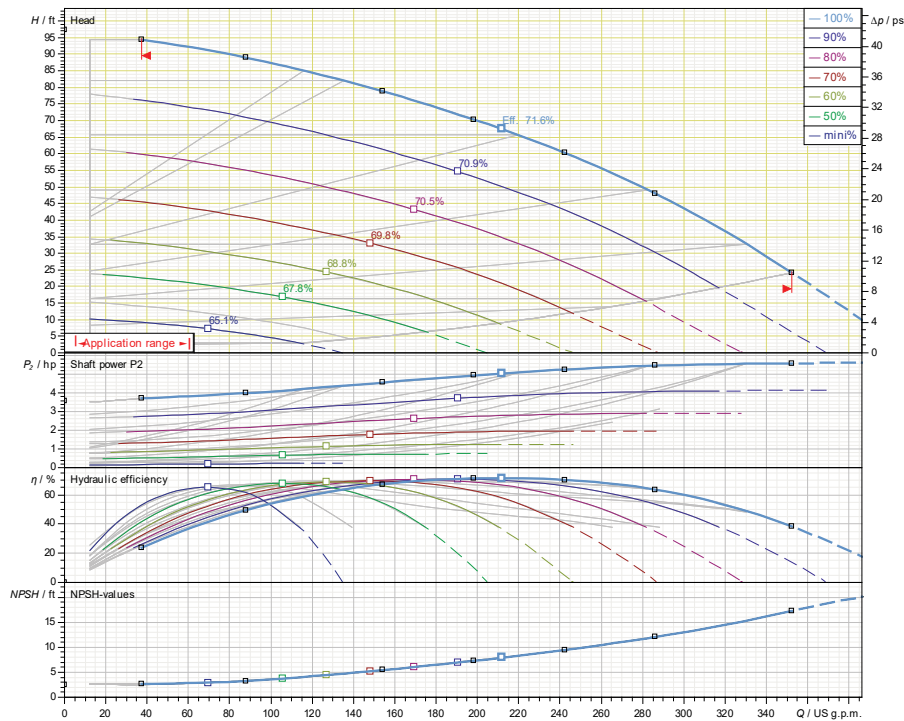

Applications

- Water Supply
- Pressure Boosting
- Agriculture
- Cooling Circuits
- Washing / Sprinkling Systems
- Condensate Return

Materials of Construction

Pump Volute	AISI304 stainless steel with ANSI flanges
Impeller	3D Laser welded AISI 304 Stainless Steel
Shaft	AISI304, AISI318 LN, or AISI431 Stainless Steel
Elastomers	EPDM
Isolation Valves	304 Stainless Steel Ball Valves
Suction/Discharge Manifolds	AISI304 Stainless Steel with Grooved System Connections
Check Valves	Wafer Style, 316 Stainless Steel internals, Non-slam, Plunger-type with EPDM seal/ Cast Iron Body
Mechanical Seal	Cartridge Seal: Sleeve AISI316L / Spring Clips AISI304
Pressure Transducers	316 Stainless Steel
Pressure Guages	304 Stainless Steel Housing with 316 Stainless Steel wetted parts
System base	Steel (S235JR)
Vibration Isolators	Neoprene, Height Adjustable

Technical Data – Operational Ranges

Liquid Temp Range	-4°F to +180°F (Min. 32 °F for Domestic Water)
Ambient Temp Range	+32°F to +104 °F
Max Inlet Pressure	145 PSI
Max System Pressure	232 PSI

Technical Data – Panel

Power Supply	460~3
Enclosure	NEMA 12 (3R Available Upon Request)
Standard	Meets UL 508A

Technical Data – Power Head

User Interface	3" Diagonal LCD with Green Button selection
Supply Voltage	24VDC
Number of Analog Inputs	2 (1 External set value/1 Pressure sensor)
Number of Analog Outputs	0
Number of Digital Inputs	1 (External On/Off)
Number of Digital Outputs	0
Optional Communications	Gateways for Modbus, BacNET, and LonWorks
Dip Switches	4

Motor Data

Power Supply	460V-3
Motor Enclosure	Totally Enclosed Fan Cooled (TEFC)
Motor Efficiency	IEC Premium Efficiency (IE5) – Electronically Commutated Motor (EC Motor with Powerhead control)
Enclosure Construction	Cast Iron
Motor Protection Index	IP55
Insulation Class	F

Approval Stamp

Submittal Data Sheet

Wilo-Helix EXCEL Complete- NSF 61/372 Pressure Boosting System



Helix EXCEL Complete V270-01/5.7/460

460 V~3

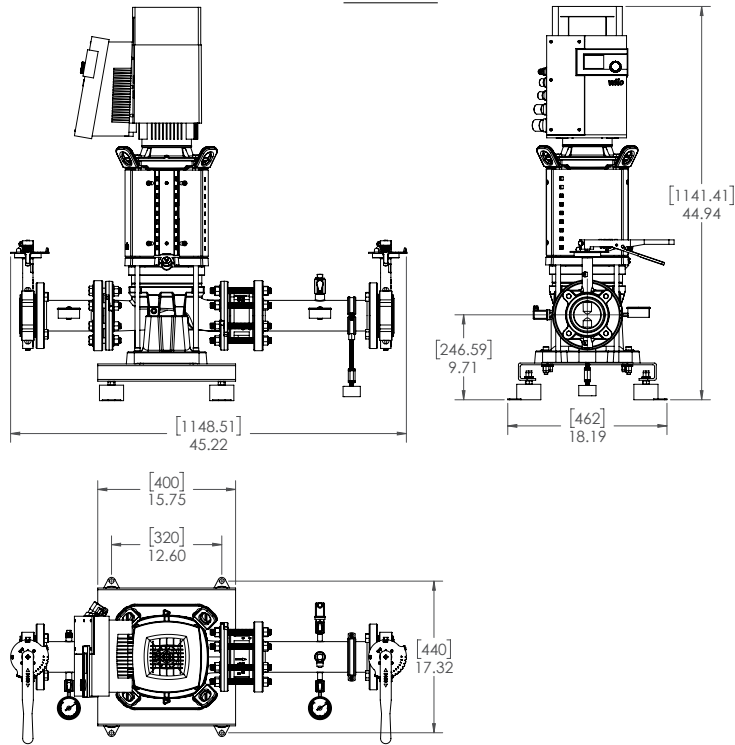

Special Note: All weights and dimensions are approximate and should not be used as exact rough-in dimensions

Dimensions and Weights

Model	Voltage (V)	System Header Size	Suction / Discharge Pump Size (150 Class ANSI)	Gauge Tap Size	Transducer Tap Size	Hydronumatic Tank Valve on Manifold (Plugged)	Pump Weight (lbs)	Package Weight (lbs)
Helix EXCEL Complete V270-01/5.7/460	460 V	3"	3"	1/4" FNPT	1/4" FNPT	3/4" MNPT x 3/4" FNPT	239	333

EC Motor Data (Single Motor Operation)

Model	P2 (HP)	P2 (KW)	Phase (-)	Voltage (V)	FLA (per pump) (A)	Efficiency η_m 100%	Pmax (PSI)
Helix EXCEL Complete V270-01/5.7/460	5.7	4.20	3	460 ($\pm 10\%$)	6.5	95.8	232.1

Submittal Data Sheet

Wilo-Helix EXCEL Complete- NSF 61/372 Pressure Boosting System



Helix EXCEL Complete V270-02/1/7.4/460



Project:	
Engineer:	
Contractor:	
Submitted By:	Date:
Approved By:	Date:

Tag #	Model #	Flow	BOOST PSI	Min. Inlet PSI	HP/Pump	Phase	Voltage	RPM
	Helix EXCEL Complete V270-02/1/7.4/460				7.4			3600

Article Number: 2700965

Helix_EXCEL_Complete_V270-02_1_7.4_460V

Applications

- Water Supply
- Pressure Boosting
- Agriculture
- Cooling Circuits
- Washing / Sprinkling Systems
- Condensate Return

Materials of Construction

Pump Volute	AISI304 stainless steel with ANSI flanges
Impeller	3D Laser welded AISI 304 Stainless Steel
Shaft	AISI304, AISI318 LN, or AISI431 Stainless Steel
Elastomers	EPDM
Isolation Valves	304 Stainless Steel Ball Valves
Suction/Discharge Manifolds	AISI304 Stainless Steel with Grooved System Connections
Check Valves	Wafer Style, 316 Stainless Steel internals, Non-slam, Plunger-type with EPDM seal/ Cast Iron Body
Mechanical Seal	Cartridge Seal: Sleeve AISI316L / Spring Clips AISI304
Pressure Transducers	316 Stainless Steel
Pressure Guages	304 Stainless Steel Housing with 316 Stainless Steel wetted parts
System base	Steel (S235JR)
Vibration Isolators	Neoprene, Height Adjustable

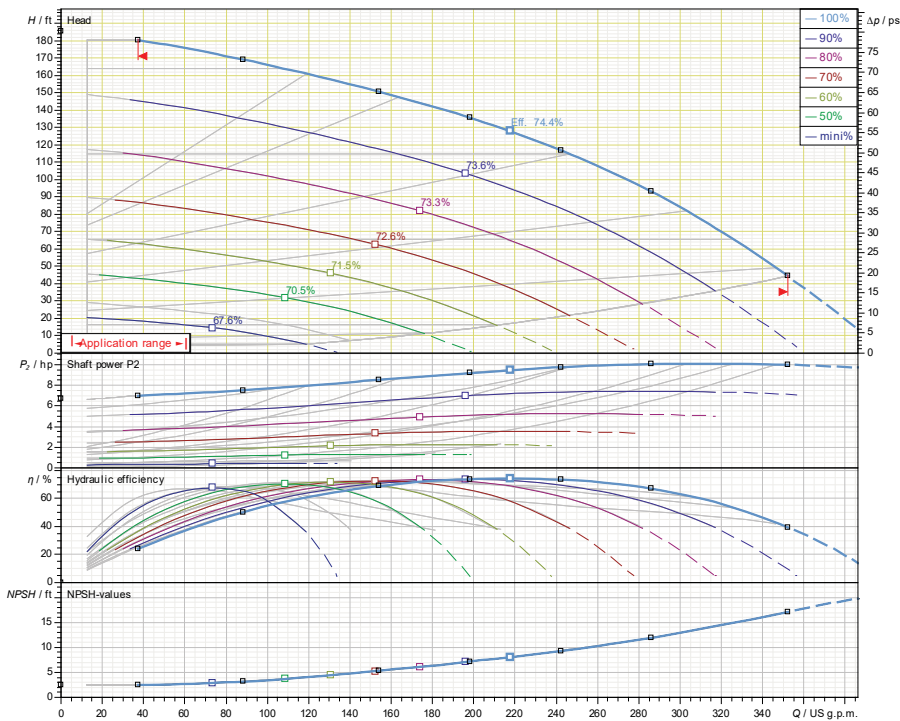

Technical Data – Operational Ranges

Liquid Temp Range	-4°F to +180°F (Min. 32 °F for Domestic Water)
Ambient Temp Range	+32°F to +104 °F
Max Inlet Pressure	145 PSI
Max System Pressure	232 PSI

Technical Data – Panel

Power Supply	460~3
Enclosure	NEMA 12 (3R Available Upon Request)
Standard	Meets UL 508A

Technical Data – Power Head

User Interface	3" Diagonal LCD with Green Button selection
Supply Voltage	24VDC
Number of Analog Inputs	2 (1 External set value/1 Pressure sensor)
Number of Analog Outputs	0
Number of Digital Inputs	1 (External On/Off)
Number of Digital Outputs	0
Optional Communications	Gateways for Modbus, BacNET, and LonWorks
Dip Switches	4

Motor Data

Power Supply	460V-3
Motor Enclosure	Totally Enclosed Fan Cooled (TEFC)
Motor Efficiency	IEC Premium Efficiency (IE5) – Electronically Commutated Motor (EC Motor with Powerhead control)
Enclosure Construction	Cast Iron
Motor Protection Index	IP55
Insulation Class	F

Approval Stamp

Submittal Data Sheet

Wilo-Helix EXCEL Complete- NSF 61/372 Pressure Boosting System



Helix EXCEL Complete V270-02/1/7.5/460

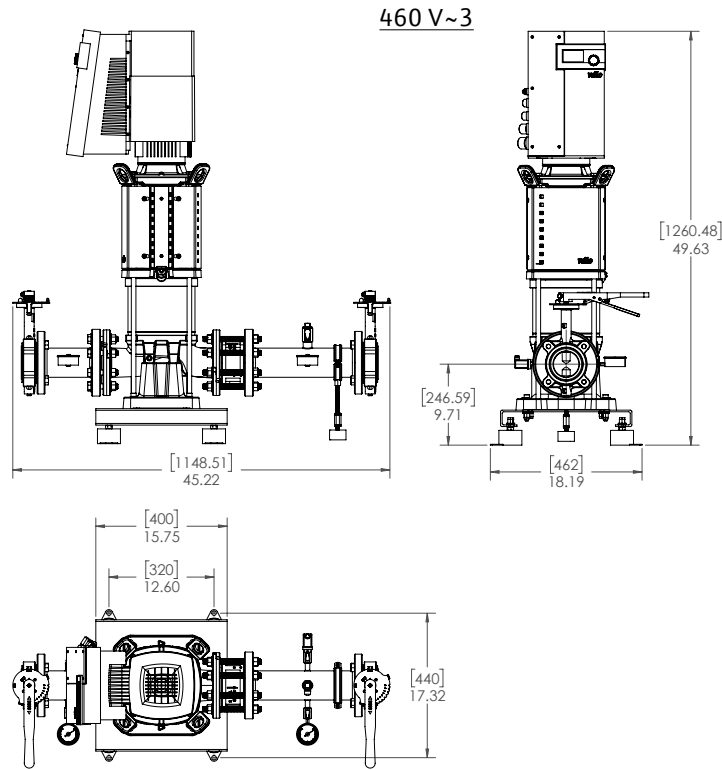

Special Note: All weights and dimensions are approximate and should not be used as exact rough-in dimensions

Dimensions and Weights

Model	Voltage (V)	System Header Size	Suction / Discharge Pump Size (150 Class ANSI)	Gauge Tap Size	Transducer Tap Size	Hydronumatic Tank Valve on Manifold (Plugged)	Pump Weight (lbs)	Package Weight (lbs)
Helix EXCEL Complete V270-02/1/7.5/460	460 V	3"	3"	1/4" FNPT	1/4" FNPT	3/4" MNPT x 3/4" FNPT	256	350

EC Motor Data (Single Motor Operation)

Model	P2 (HP)	P2 (KW)	Phase (-)	Voltage (V)	FLA (per pump) (A)	Efficiency η_m 100%	Pmax (PSI)
Helix EXCEL Complete V270-02/1/7.5/460	7.4	5.50	3	460 ($\pm 10\%$)	10.9	96.4	232.1

Submittal Data Sheet

Wilo-Helix EXCEL Complete- NSF 61/372 Pressure Boosting System



Helix EXCEL Complete V270-02/10/460

	Project:							
	Engineer:							
	Contractor:							
	Submitted By:				Date:			
	Approved By:				Date:			
Tag #	Model #	Flow	BOOST PSI	Min. Inlet PSI	HP/Pump	Phase	Voltage	RPM
	Helix EXCEL Complete V270-02/10/460				10			3600

Article Number: 2700966

Helix_EXCEL_Complete_V270-02_10.1_460V

Applications

- Water Supply
- Pressure Boosting
- Agriculture
- Cooling Circuits
- Washing / Sprinkling Systems
- Condensate Return

Materials of Construction

Pump Volute	AISI304 stainless steel with ANSI flanges
Impeller	3D Laser welded AISI 304 Stainless Steel
Shaft	AISI304, AISI318 LN, or AISI431 Stainless Steel
Elastomers	EPDM
Isolation Valves	304 Stainless Steel Ball Valves
Suction/Discharge Manifolds	AISI304 Stainless Steel with Grooved System Connections
Check Valves	Wafer Style, 316 Stainless Steel internals, Non-slam, Plunger-type with EPDM seal/ Cast Iron Body
Mechanical Seal	Cartridge Seal: Sleeve AISI316L / Spring Clips AISI304
Pressure Transducers	316 Stainless Steel
Pressure Guages	304 Stainless Steel Housing with 316 Stainless Steel wetted parts
System base	Steel (S235JR)
Vibration Isolators	Neoprene, Height Adjustable

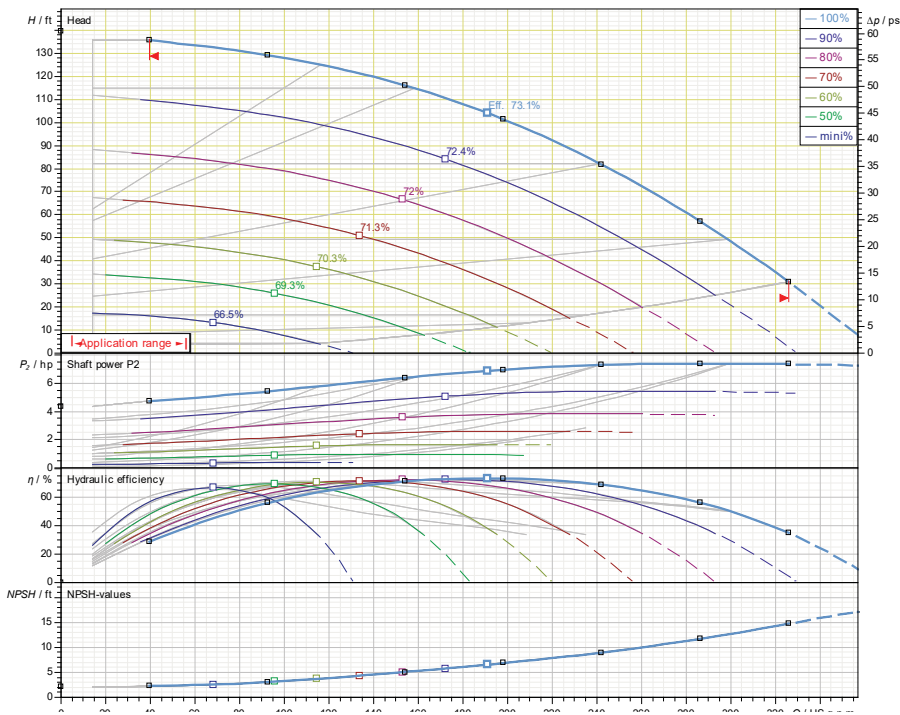

Technical Data – Operational Ranges

Liquid Temp Range	-4°F to +180°F (Min. 32 °F for Domestic Water)
Ambient Temp Range	+32°F to +104 °F
Max Inlet Pressure	145 PSI
Max System Pressure	232 PSI

Technical Data – Panel

Power Supply	460~3
Enclosure	NEMA 12 (3R Available Upon Request)
Standard	Meets UL 508A

Technical Data – Power Head

User Interface	3" Diagonal LCD with Green Button selection
Supply Voltage	24VDC
Number of Analog Inputs	2 (1 External set value/1 Pressure sensor)
Number of Analog Outputs	0
Number of Digital Inputs	1 (External On/Off)
Number of Digital Outputs	0
Optional Communications	Gateways for Modbus, BacNET, and LonWorks
Dip Switches	4

Motor Data

Power Supply	460V-3
Motor Enclosure	Totally Enclosed Fan Cooled (TEFC)
Motor Efficiency	IEC Premium Efficiency (IE5) – Electronically Commutated Motor (EC Motor with Powerhead control)
Enclosure Construction	Cast Iron
Motor Protection Index	IP55
Insulation Class	F

Approval Stamp

Submittal Data Sheet

Wilo-Helix EXCEL Complete- NSF 61/372 Pressure Boosting System



Helix EXCEL Complete V270-02/10/460

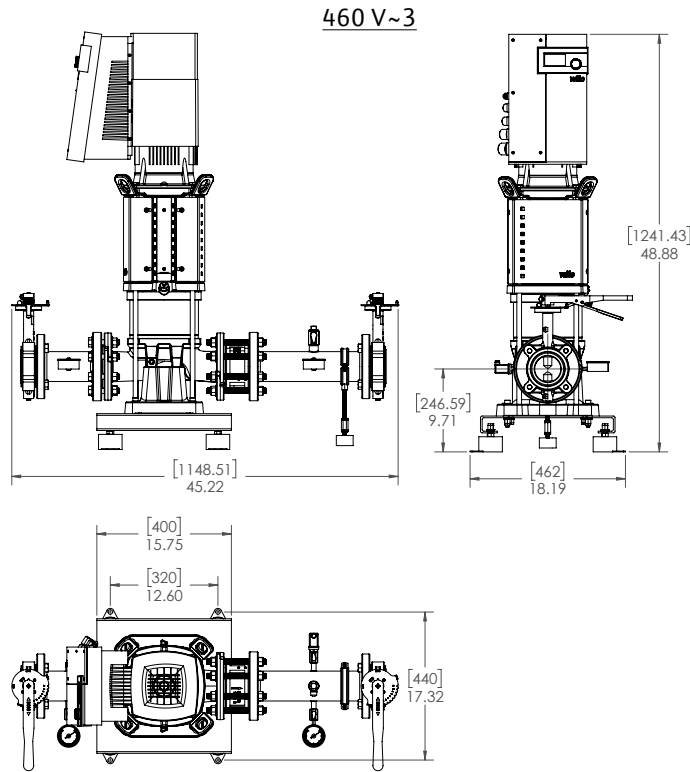

Special Note: All weights and dimensions are approximate and should not be used as exact rough-in dimensions

Dimensions and Weights

Model	Voltage (V)	System Header Size	Suction / Discharge Pump Size (150 Class ANSI)	Gauge Tap Size	Transducer Tap Size	Hydronumatic Tank Valve on Manifold (Plugged)	Pump Weight (lbs)	Package Weight (lbs)
Helix EXCEL Complete V270-02/10/460	460 V	3"	3"	1/4" FNPT	1/4" FNPT	3/4" MNPT x 3/4" FNPT	265	359

EC Motor Data (Single Motor Operation)

Model	P2 (HP)	P2 (KW)	Phase (-)	Voltage (V)	FLA (per pump) (A)	Efficiency η_m 100%	Pmax (PSI)
Helix EXCEL Complete V270-02/10/460	10.1	7.50	3	460 ($\pm 10\%$)	9.7	96.4	232.1