

Submittal Data Sheet

Vertical Multistage Pumps

Wilo-Helix



Project:	
Engineer:	
Contractor:	
Submitted By:	Date:
Approved By:	Date:

Tag #	Model #	Flow	Head	Volute	Control Mode	HP	Phase	Voltage
	Helix V 50							

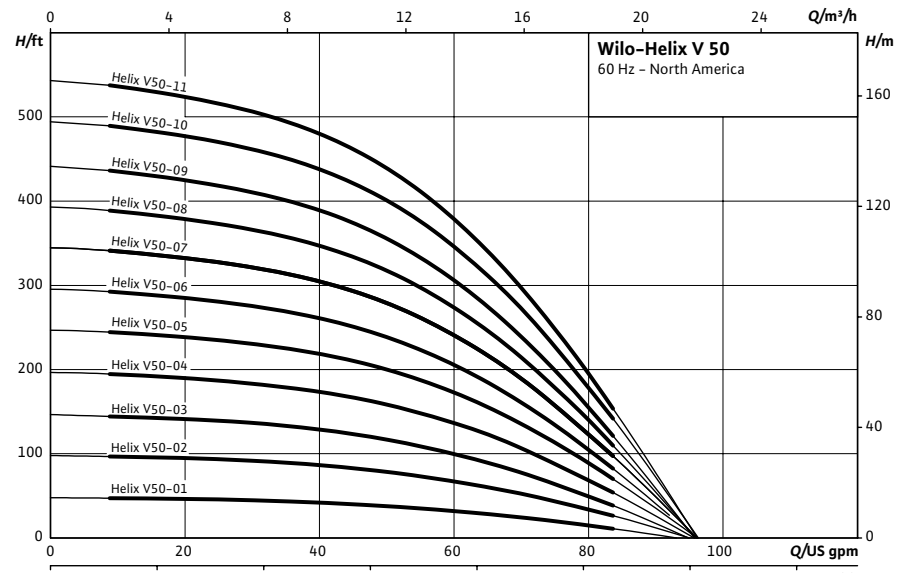

Product Info

Brand	Wilo
Product Description	Helix V 50

Technical Data

PEI	(See page 2)
Certification	NSF 61 Approved (EPDM)
Liquid Temp Range	-4°F to +248°F
Power Supply	3~ 208-230v, 3~ 460v, 3~ 575v
Ambient Temperature	+5°F to +104°F
Flange Connection	ANSI CLASS 300
Max Operating Pressure	232/363 PSI
Protection Class	IP 55

Construction Materials

Pump Volute, flanges, impeller, stage housing, diffusers	Stainless steel AISI 304
Shaft	Stainless steel AISI 304 or AISI 316LN (Depending on version)
Shaft sleeves	Stainless Steel AISI 316L
Baseplate & lantern	Cast Iron Cataphoresis Coated ASTM A 48 Class 35/40
O-ring	EPDM (FKM upon request)
Jacket pipe	Stainless Steel AISI 304

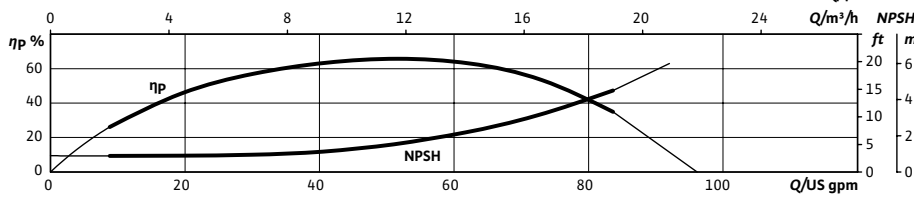

Applications

- | | |
|-------------------------------------|----------------------------------|
| • Water supply & pressure boosting | • Industrial circulation systems |
| • Cooling water circulation systems | • Process water |
| • Washing systems | • Irrigation |

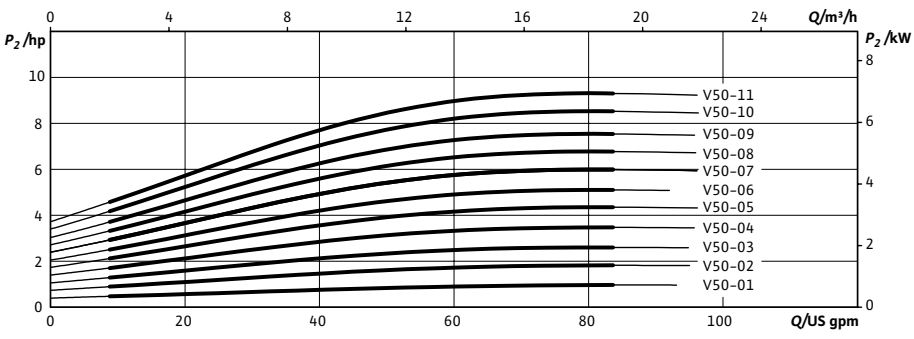

Approval Stamp

Submittal Data Sheet

Vertical Multistage Pumps

Wilo-Helix

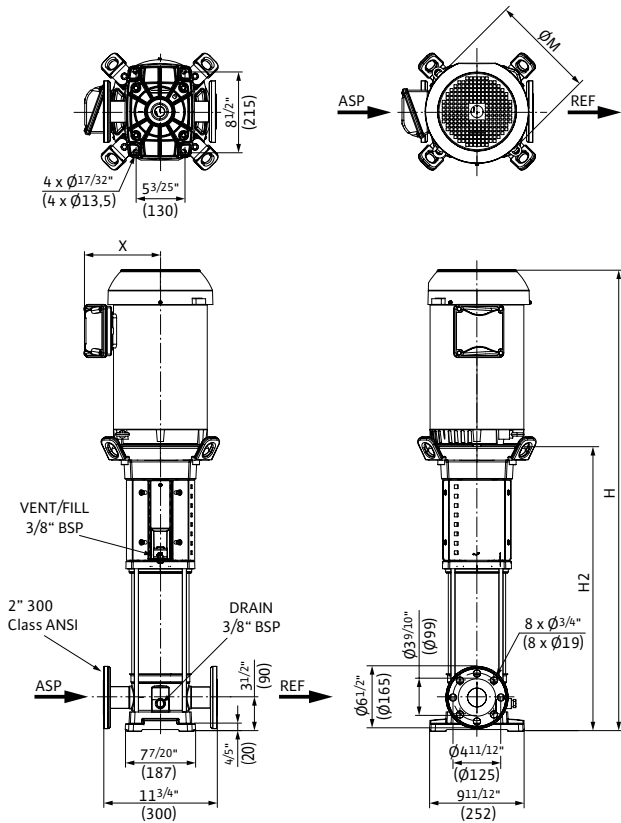

Dimensions and Weights

Model	PEI	H		H ₂	Ø M		X		Weight		
		in	mm		in	mm	in	mm	lbs	kg	
Helix V 50-1	-	26 ^{1/16}	662	17	432	6 ^{11/16}	170	9	229	72	32.66
Helix V 50-2	0.94	28 ^{13/16}	732	17	432	7 ^{5/8}	194	10	254	93	42.18
Helix V 50-3	0.94	31 ^{1/2}	800	19	483	7 ^{3/8}	187	10	254	101	45.81
Helix V 50-4	0.91	37 ^{5/8}	956	21	533	9 ^{7/16}	240	11	279	133	60.33
Helix V 50-5	0.90	39 ^{1/8}	994	22	559	9 ^{7/16}	240	11	279	142	64.41
Helix V 50-6	0.90	40 ^{9/16}	1030	24	610	9 ^{7/16}	240	11	279	144	65.32
Helix V 50-7	0.91	48 ^{11/16}	1237	30	762	10 ^{15/16}	278	13	330	199	90.26
Helix V 50-8	0.90	50 ^{3/16}	1275	31	787	10 ^{15/16}	278	13	330	223	101.15
Helix V 50-9	0.90	51 ^{5/8}	1311	33	838	10 ^{15/16}	278	13	330	226	102.51
Helix V 50-10	0.90	53 ^{1/8}	1349	34	864	10 ^{15/16}	278	13	330	226	102.51
Helix V 50-11	0.90	57 ^{11/16}	1465	37	940	10 ^{15/16}	278	13	330	258	117.03

TEFC Motor Data

P2	1-115/230 V		3-208-230/460 V		3-575 V	
	FLA	FLA	FLA	FLA	FLA	FLA
1	16	3.32-3/1.5	1.2			
2	23	5.46-4.94/2.47	1.98			
3	-	7.76-7.02/3.51	2.81			
5	-	13.1-11.8/5.9	4.72			
5	-	13.1-11.8/5.9	4.72			
5	-	13.1-11.8/5.9	4.72			
7.5	-	19.2-17.3/8.67	6.94			
7.5	-	19.2-17.3/8.67	6.94			
7.5	-	19.2-17.3/8.67	6.94			
7.5	-	19.2-17.3/8.67	6.94			
10	-	25.4-23/11.5	9.2			