

**480 Series Vertical Turbine  
Open & Enclosed Lineshaft, Submersible, Axial & Mixed Flow Pumps**

**Installation and Operating Manual**

## Contents

5	Safety considerations
6	Pump identification
6	Manufacturer
6	Type of pump
6	Date of manufacture
6	Installation, operation & maintenance manual identification
6	Warranty
6	General instructions
7	Handling and transport
7	Method of transport
7	Storage
8	Introduction
9	Receiving the pump
9	Unloading the pump
10	The sump
10	The suction vessel
11	Well (or sump) requirements
11	Recommended procedure for baseplate installation
12	General precautions
13	Installing the pump factory assembled unit
13	Parts preparation and cleaning
14	Installing the pump factory unassembled unit
14	Baseplate
15	Suction pipe and strainer
15	Bowl assembly
16	Large bowl assemblies
16	Column-open lineshaft
18	Column-enclosed lineshaft
19	Discharge head
20	Alignment
21	Stuffing box
21	Driver and drive coupling
21	Vertical hollow shaft
23	Vertical solid shaft
24	Miscellaneous equipment
24	Lubricating devices
25	Air release valve
25	Miscellaneous accessories
25	Electrical connections
26	Air line

26	Connecting the piping
26	Starting the pump
26	Initial start up
28	Normal operation and maintenance
28	Troubleshooting
33	Spare parts
33	Recommended spare parts
33	How to order spare parts

## SAFETY CONSIDERATIONS

The American-Marsh 480 Series Vertical Turbine pumps have been designed and manufactured for safe operation. In order to ensure safe operation, it is very important that this manual be read in its entirety prior to installing or operating the system. American-Marsh Pumps shall not be liable for physical injury, damage or delays caused by a failure to observe the instructions for installation, operation and maintenance contained in this manual.

Remember that every pump has the potential to be dangerous, because of the following factors:

- Parts are rotating at high speeds
- High pressures may be present
- High temperatures may be present
- Highly corrosive and/or toxic chemicals may be present

Paying constant attention to safety is always extremely important. However, there are often situations that require special attention. These situations are indicated throughout this book by the following symbols:



**DANGER** - Immediate hazards which **WILL** result in severe personal injury or death.



**WARNING** - Hazards or unsafe practices which **COULD** result in severe personal injury or death.



**CAUTION** - Hazards or unsafe practices which **COULD** result in minor personal injury or product or property damage.

Maximum Lifting Speed: 15 feet/second.

If in a climate where the fluid in the system could freeze, never leave liquid in the pump. Drain the system completely. During winter months and cold weather, the liquid could freeze and

damage the system components.

Do not run the equipment dry or start the pump without the proper prime (flooded system).

Never operate the pump(s) for more than a short interval with the discharge valve closed. The length of the interval depends on several factors including the nature of the fluid pumped and its temperature. Contact American-Marsh Engineering for additional support if required.

Never operate the system with a closed suction valve.

Excessive pump noise or vibration may indicate a dangerous operating condition. The pump(s) must be shutdown immediately.

Do not operate the pump and/or the system for an extended period of time below the recommended minimum flow.

It is absolutely essential that the rotation of the motor be checked before starting any pump in the system. Incorrect rotation of the pump(s) for even a short period of time can cause severe damage to the pumping assembly.

If the liquid is hazardous, take all necessary precautions to avoid damage and injury before emptying the pump casing.

Always lockout power to the driver before performing pump maintenance.

Never operate the pump without the coupling guard (if supplied) and all other safety devices correctly installed.

Do not apply heat to disassemble the pump or to remove the impeller. Entrapped liquid could cause an explosion.

If any external leaks are found while pumping hazardous product, immediately stop operations and repair.

## PUMP IDENTIFICATION

### MANUFACTURER

American-Marsh Pumps  
550 E. South St.  
Collierville, TN 38017  
United States of America

### TYPE OF PUMP

The American-Marsh vertical turbine pump is a multistage, centrifugal.

### DATE OF MANUFACTURE

The date of manufacture is indicated on the pump data plate.

## INSTALLATION, OPERATION & MAINTENANCE MANUAL IDENTIFICATION

Prepared: October, 2021      Edition: 02  
Revision: A Wilo Brand      Date of Revision:  
11-10-22

### NAMEPLATE INFORMATION

The image shows a rectangular nameplate with a black border. At the top left, there are three input fields labeled 'SER. NO.', 'MODEL', and 'TYPE'. In the center, there is a logo for 'AMERICAN-MARSH PUMPS' with a stylized bird above it and 'A WILCO COMPANY' below it. Below the logo, there are three input fields labeled 'RPM', 'GPM', and 'TDH'. At the bottom left, there are two input fields labeled 'Imp. Dia.(in)' and 'PEI'. At the bottom right, there is a small input field labeled 'PEI'. At the very bottom, there is a website address 'www.american-marsh.com' and a phone number '(800) 888-7167'. There are also two small circular symbols with a crosshair inside, one on the left and one on the right, flanking the 'TYPE' field.

FIGURE 1 – Pump Data Plate (Discharge Head & Suction Bell/Case Tag)

MODEL:	Model of pump bowl
SERIAL NUMBER:	Serial Number of pump unit (issued by Production Control)
STAGES:	Number of pump bowls
GPM:	Rated capacity of pump
TDH:	Rated Total Dynamic Head of pump
RPM:	Rotational speed of pump
BHP:	Brake horsepower required
IMPELLER:	Impeller diameter in inches
DISCHARGE:	Discharge size of pump in inches
SUCTION:	Suction size of pump in inches

## WARRANTY

American-Marsh Pumps guarantees that only high quality materials are used in the construction of our pumps and that machining and assembly are carried out to high standards.

The pumps are guaranteed against defective materials and/or faulty craftsmanship for a period of one year from the date of shipment unless specifically stated otherwise.

Replacement of parts or of the pump itself can only be carried out after careful examination of the pump by qualified personnel.

The warranty is not valid if third parties have tampered with the pump.

This warranty does not cover parts subject to deterioration or wear and tear (mechanical seals, pressure and vacuum gauges, rubber or plastic items, bearings, etc.) or damage caused by misuse or improper handling of the pump by the end user.

Parts replaced under warranty become the property of American-Marsh Pumps.

Contact the American-Marsh Pumps' factory:

American-Marsh Pumps  
550 E. South St.  
Collierville, TN 38017  
United States Of America

Phone: (901) 860-2300  
Fax: (901) 860-2323

# GENERAL INSTRUCTIONS

The pump and motor unit must be examined upon arrival to ascertain any damage caused during shipment. If damaged immediately notify the carrier and/or the sender. Check that the goods correspond exactly to the description on the shipping documents and report any differences as soon as possible to the sender. Always quote the pump type and serial number stamped on the data plate.

The pumps must be used only for applications for which the manufacturers have specified:

- The construction materials
- The operating conditions (flow, pressure, temperature, etc.)
- The field of application

In case of doubt, contact the manufacturer.

## HANDLING AND TRANSPORT

### METHOD OF TRANSPORT

The pump must be transported in the horizontal position

### INSTALLATION

During installation and maintenance, all components must be handled and transported securely by using suitable slings. Handling must be carried out by specialized personnel to avoid damage to the pump and persons. The lifting rings attached to



various components should be used exclusively to lift the components for which they have been supplied.

*Maximum lifting speed: 15 feet/second*

It is important to exercise extreme care in handling and installing all parts. Certain items are precision machined for proper alignment and, if dropped, banged, sprung, or mistreated in any way, misalignment and malfunction will result. Other components, such as the electrical cable, may be vulnerable to gouging or scuffing. Parts which are too heavy to be lifted from the transporting car or truck should be skidded slowly and carefully to the ground to prevent damage. Never unload by dropping parts directly from the carrier to the ground and never use shipping crates for skids.

If job site conditions permit, you may be able to install directly

from the truck that delivered the pump. If not, move the components to the installation area and lay them out in a clean and protected space convenient to the work location. Column pipe sections should be placed on suitable timbers to keep them out of the dirt, arranged so that the coupling ends point toward the wellhead. The bowl/motor assembly should be left on the skids until lifted for installation. The power cable and motor leads must receive special protection to avoid damage to jacket or insulation.

If installation cannot begin within a few days after delivery, segregate and identify all components of the shipment so they won't be confused with other equipment arriving at the job site.

Read and follow the storage instructions carefully because care of the pump during this period before installation can be as important as maintenance after operation has begun.

Check all parts against the packing list to make sure nothing is missing. It is much better to find out now than during the installation.

## STORAGE

### SHORT-TERM STORAGE

Normal packaging is designed to protect the pump during shipment and for dry, indoor storage for up to two months or less. The procedure followed for this short-term storage is summarized below:

Standard Protection for Shipment :

a. Loose unmounted items, including, but not limited to, oilers, packing, coupling spacers, stilts, and mechanical seals are packaged in a water proof plastic bag and placed under the coupling guard. Larger items are cartoned and metal banded to the base plate. For pumps not mounted on a base plate, the bag and/or carton is placed inside the shipping carton. All parts bags and cartons are identified with the American-Marsh sales order number, the customer purchase order number, and the pump item number (if applicable).

b. Inner surfaces of the bearing housing, shaft (area through bearing housing), and bearings are coated with Cortec VCI-329 rust inhibitor, or equal.

*Note: Bearing housings are not filled with oil prior to shipment.*

c. Regreasable bearings are packed with grease (Exxon Mobile Polyrex EM).

d. After a performance test, if required, the pump is

tipped on the suction flange for drainage (some residual water may remain in the casing). Then, internal surfaces of ferrous casings, covers, flange faces, and the impeller surface are sprayed with Calgon Vestal Labs RP-743m, or equal. Exposed shafts are taped with Polywrap.

e. Flange faces are protected with plastic covers secured with plastic drive bolts. 3/16 in (7.8 mm) steel or 1/4 in (6.3 mm) wood covers with rubber gaskets, steel bolts, and nuts are available at extra cost.

f. All assemblies are bolted to a wood skid which confines the assembly within the perimeter of the skid.

g. Assemblies with special paint are protected with a plastic wrap.

h. Bare pumps, when not mounted on base plates, are bolted to wood skids.

i. All assemblies having external piping (seal flush and cooling water plans), etc. are packaged and braced to withstand normal handling during shipment. In some cases components may be disassembled for shipment. The pump must be stored in a covered, dry location.

## LONG-TERM STORAGE

Long-term storage is defined as more than two months, but less than 12 months. The procedure American-Marsh follows for long-term storage of pumps is given below. These procedures are in addition to the short-term procedure.

Solid wood skids are utilized. Holes are drilled in the skid to accommodate the anchor bolt holes in the base plate, or the casing and bearing housing feet holes on assemblies less base plate. Tackwrap sheeting is then placed on top of the skid and the pump assembly is placed on top of the Tackwrap. Metal bolts with washers and rubber bushings are inserted through the skid, the Tackwrap, and the assembly from the bottom of the skid and are then secured with hex nuts. When the nuts are “snugged” down to the top of the base plate or casing and bearing housing feet, the rubber bushing is expanded, sealing the hole from the atmosphere. Desiccant bags are placed on the Tackwrap. The Tackwrap is drawn up around the assembly and hermetically (heat) sealed across the top. The assembly is completely sealed from the atmosphere and the desiccant will absorb any entrapped moisture. A solid wood box is then used to cover the assembly to provide protection from the elements and handling. This packaging will provide protection up to twelve months without damage to mechanical seals, bearings, lip seals, etc. due to humidity, salt laden air, dust, etc. After unpacking, protection will be the responsibility of the user. Addition of oil to the bearing housing will remove the inhibitor. If units are to be idle

for extended periods after addition of lubricants, inhibitor oils and greases should be used.

Every three months, the shaft should be rotated approximately 10 revolutions.

## INSTALLATION

### INTRODUCTION

Efficient performance, satisfactory operation and dependable service.

We know these are the things you want from your vertical turbine pump and we've designed it accordingly. We've prepared this booklet to help you assure continuance of these features by implementing a careful and proper installation, operation and maintenance program. If you want further assistance, you might consider contracting for the services of a factory service representative to supervise your installation and/or startup.

Because of variations in jobsite environments and installation requirements, we've had to be somewhat general. However, we have listed what we believe are the most important guidelines. Your installer must still use sound judgment to adapt the methods we've outlined to the specific site circumstances and pump design features in each particular installation. It is in your interest that he does, since failure to comply with recommended procedures may void your warranty.

If any question should arise during the course of the work, we urge you to see your local representative immediately. Please be able to identify the unit by its serial number. We stamp the number on the nameplate that can be found on the discharge head and on the bowl assembly.

Figure 2 will show you the relationship of all the parts after installation is complete. The nomenclature we've used here will identify the items throughout the instructions. Before starting the installation procedure, please read through the entire process we've described in this book, omitting material not applicable to your particular pump.

Then, when you do start the work, refer to the instructions for each individual step. After the equipment is in operation, we suggest you keep a manual available at the site for future use in maintenance programs. It can be used in conjunction with the disassembly, assembly and troubleshooting manuals.

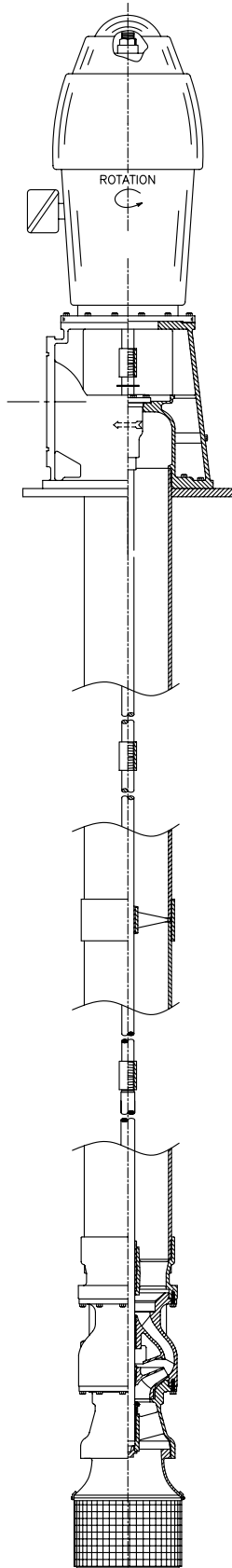

Hoisting equipment capable of controlled hoisting and lowering of the combined weight of the pump, motor, drop cable, column pipe, and discharge head.

## **WARNING**

FIGURE 2 – Overall Pump Layout

*The height of the equipment must be sufficient to accommodate the longest component to be installed.*

Pipe elevators (or equivalent) and lifting bail (or equivalent) for handling and installing sections of column pipe. The eleva-

## **CAUTION**

tors and lifting bail must be capable of carrying the combined weight of the pump, motor, drop cable, and column pipe.\*

*Equipment for removal of the pump after it has been in operation must be capable of lifting the above weight plus the weight of the water in the column pipe.*

### RECEIVING THE PUMP

Immediately upon receipt, check that the number of boxes and pieces received is the same as shown on the freight bills. Check for shipping damage. Note any shortages or damages on the carrier's copy of the freight bill prior to signing. Report these damages or shortages to the factory or your local factory representative immediately.

If facilities are not available for lifting the materials off the carrier's vehicle, use skids for unloading rather than allowing the parts to drop to the ground. Even though a pump is made up of heavy steel parts, it is a piece of machinery and it is essential that its parts be handled with care. It is extremely easy to damage shafting, threaded parts, and mating surfaces of parts which must fit together. Even a minor bend in one piece of shafting can cause a pump to vibrate excessively; thus shortening the life of the pump drastically.

Also check that the parts received are all of the parts required for the installation. Report any shortages or errors to the factory or your local factory representative immediately.



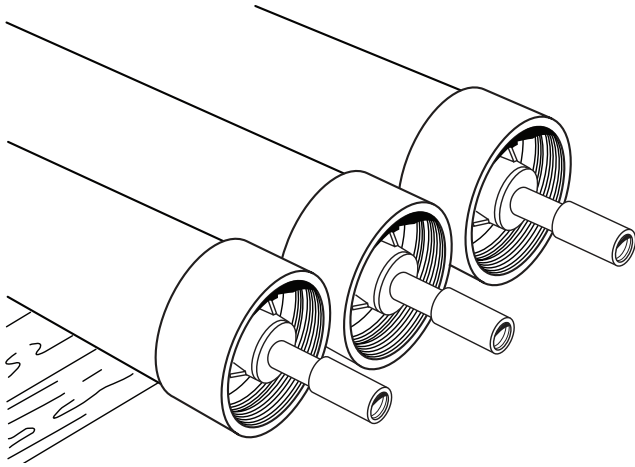

FIGURE 3 – Supported Pipe

Follow the Manufacturer's instructions for handling and storing the driver and any other special equipment.

## UNLOADING THE PUMP

It is important to exercise extreme care in handling and installing all parts, particularly the shaft and enclosing tube. All items are precision machined for proper alignment and, if dropped, banged, sprung or mistreated in any way, misalignment and malfunction will result. Parts which are too heavy to be lifted from the transporting car or truck should be skidded slowly and carefully to the ground so as to prevent injury. Never unload by dropping parts directly from the carrier to the ground and never use shipping crates for skids.

If your pump is short enough, say a hundred foot setting or less, you might be able to install directly from the truck that brought it to you. If the truck driver has the time and if he can back his vehicle in close to the wellhead the parts can be handled directly from the truck bed by the pump rig as the installation progresses.

For longer units, layout column pipe and bowl assembly on suitable timbers or staging to keep all material out of the dirt. See Figure 3. Position coupling ends toward the wellhead. Inner column joints consisting of shafting and/or tubing with line shaft bearings will have been preassembled for you at the factory into proper lengths to match the column pipe. Insert these assemblies into the matching pipe sections, with the projecting line shaft bearing pointing toward the well. See Figure 4 for enclosed line shaft and Figure 5 for open line shaft.

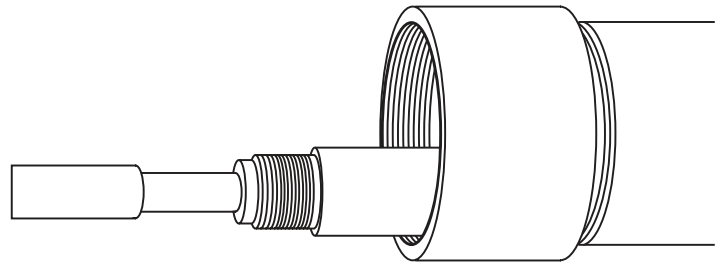

FIGURE 4 – Enclosed Line Shaft

Tube faces should be inspected to see that they are free from burrs or nicks and, in the process, should be wiped clean. Sections that have been assembled at the factory should be checked for tightness by your installer to insure none have loosened in transit. He should also check each joint for straightness as a bent tube cannot be used. Keep ends covered until each is ready for installation.

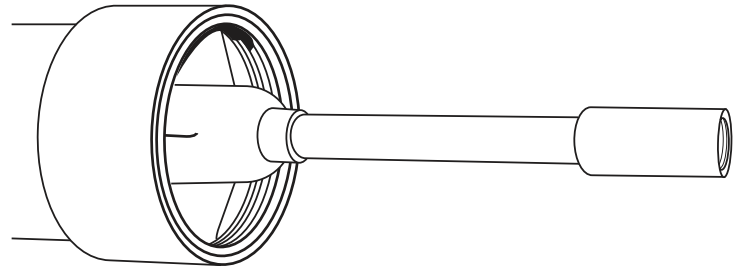

FIGURE 5 – Open Line Shaft

If the line shaft was received in a crate, we suggest you handle it directly from the crate. If not, place each length on timbers and clean with solvent to remove rust preventive, oil, or flushing compound. In either case, inspect each joint to make sure the faces are undamaged and that the piece is absolutely straight. Each was straightened before shipment from the factory and if any were bent in transit, they cannot be used. Keep ends covered until ready for installation.

All other parts should be cleaned and laid out on a suitable surface in the order in which you'll want to use them. Check all parts against your packing list to be sure none are missing. It's much better to find out now, than during the installation.

## THE SUMP

The sump you provide can influence both the mechanical and hydraulic performance of your pump. The intake configuration should be designed to deliver an evenly distributed flow of water to the pump suction since uneven flow patterns tend to create vortices. Vortexing can be submerged and completely invisible, or, it can appear on the surface. It can introduce air into the pump, can increase or decrease power consumption, can influence submergence requirement, and can produce objectionable noise and vibration, among other things.

It's easy to be misled by low calculated average velocities across an intake channel, but keep in mind these figures can often mean absolutely nothing. It's the localized velocities that start the vortex. Actually, vortices are more easily sustained in flows of lower average velocities where a calm slowly moving surface does nothing to interfere with a gradual buildup in vortex size. A more turbulent surface can tend to break up these disturbances before they grow large enough to cause harm.

The Standards of the Hydraulic Institute offers certain guidelines for good pit design and we subscribe to these general principles. However, we recommend you put your sump design questions in the hands of an experienced sump design engineer who can match intake configuration with pump requirements in the plant design phase and make it possible for you to realize optimum performance from each.

Before starting installation, inspect the completed sump carefully. You'll want to make sure it's dimensionally adequate to receive the pump. You'll also want to see that it has been cleared of all trash and debris. Your inspection should include any pipelines or conduits feeding into the pit. It's a good idea to have the basin screened to prevent future entrance of foreign material which can damage or clog the pump, possibly even rendering it inoperative.

If a suction vessel is used, see additional instruction labeled **THE SUCTION VESSEL** below.

## THE SUCTION VESSEL

Not applicable for pumps installed in an open sump. See **THE SUMP** above.

If your pump is a suction cased booster, your suction vessel may have been furnished with the pump or you may have procured it from another source. In either event, the vessel should be lowered into the pit, leveled, and grouted or otherwise secured in place, after which the nuts may be tightened firmly on the vessel anchor bolts. These bolts may be similar to those discussed in **RECOMMENDED PROCEDURE FOR BASEPLATE INSTALLATION** on page 20.

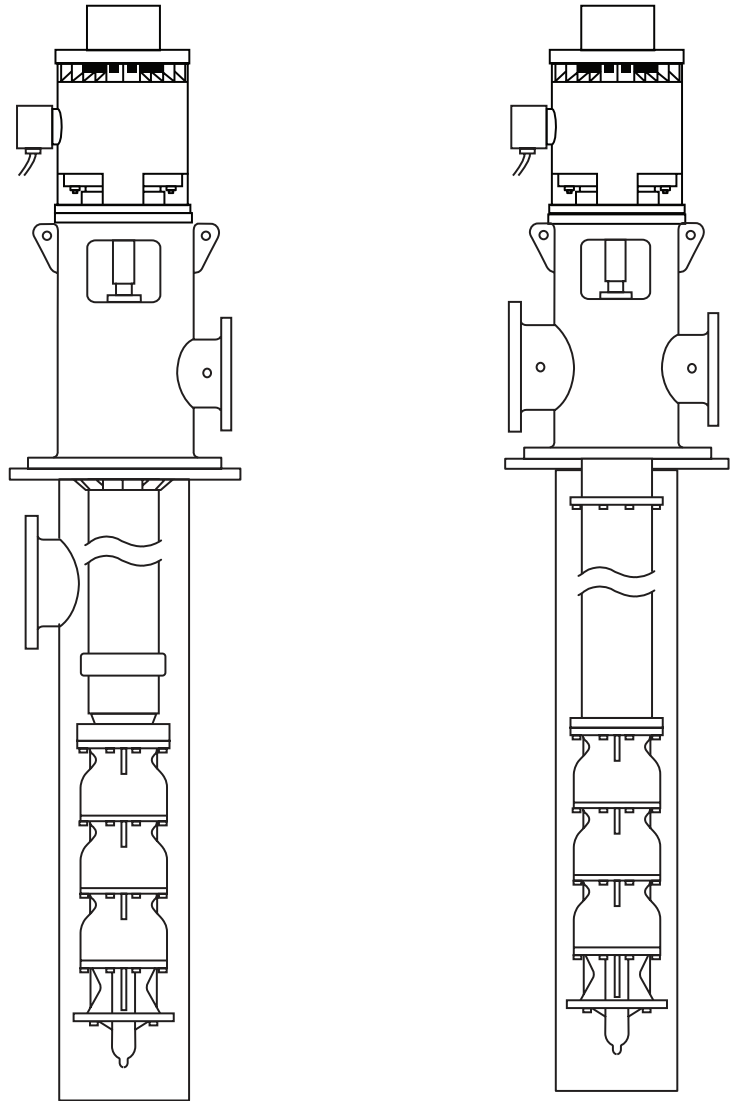

FIGURE 6 – Suction Vessel Assemblies

You must set the vessel so that the machined portion of the top flange is level within a maximum of 0.007 inches per linear foot across the flange face. Bolt holes must be located so that the suction and discharge nozzles are in proper orientation for your jobsite piping.

In some installations, concrete is poured around the outside of the vessel after positioning. In other instances, the tank may be set in the ground with a higher water table surrounding. In these or similar situations, you must take proper measures to prevent the barrel from floating out of position. You may use any suitable means, including firm anchoring and bracing, or you may want to fill the vessel itself with water to eliminate its buoyancy.

Velocities and flow patterns in the vessel can be critical to the operation of the pump. If the tank is designed and/or furnished by any source other than the factory, the configuration must be

approved by factory authorized engineers before the pump warranty will be validated.

After you've set the vessel, and during the installation of the pump, you must provide protective cover for the machined surface of the barrel flange.

Typical assemblies of this type are illustrated in Figure 6.

## WELL (OR SUMP) REQUIREMENTS

The well must comply with applicable codes.

The well should be developed with a test pump prior to installation. Test pumping the well serves several purposes. It removes the excess sand encountered during the initial pumping of the well. Attempting to pump mud or sand with a vertical turbine pump can damage the pumping unit. Test pumping also provides a means of determining the capacity and drawdown (lowering of the water level in the well during pumping). Pumping sand or other abrasives with a turbine pump will shorten the life of the pump and can void the warranty.

The well capacity should equal or exceed the pump capacity. If the pump removes water at a higher rate than the well produces, the drawdown will be excessive and the pump will cavitate or "starve" resulting in damage to the pump and motor.

The well must be deep enough so that the pump suction is at least 10 feet below the expected drawdown level. The lower end of the pump should be at least 10 feet from the bottom of the well.

The flow rate must be adequate to cool the motor. If the pump is set below the well screen openings or other conditions exist that cause the water to be supplied from above the pump, a flow inducer sleeve may be required. Flow inducer sleeves are generally required for all pit or tank applications. Detailed information concerning the required flow rate around the motor and the design of flow inducer sleeves is given in the motor manual.

Water temperature in excess of 80 degrees F. may require special considerations concerning the pump motor. See the motor manual and, if necessary, contact the factory.

The inside diameter of the well casing must be large enough to allow lowering the unit into the well without damaging the drop cable, the splice between the drop cable and the motor leads, or the motor leads. A slightly enlarged area may be required immediately underneath the discharge head to prevent pinching the cable against the well casing. The drop cable must be pulled away from the column pipe in this area to allow it to pass through the threaded opening in the surface plate of the discharge head.

## RECOMMENDED PROCEDURE FOR BASEPLATE INSTALLATION

### NEW GROUTED BASE PLATES

1. There should be adequate space for workers to install, operate, and maintain the pump. The foundation should be sufficient to absorb any vibration and should provide a rigid support for the pump and motor. Recommended mass of a concrete foundation should be three times that of the pump, motor and base. Note that foundation bolts are imbedded in the concrete inside a sleeve to allow some movement of the bolt.

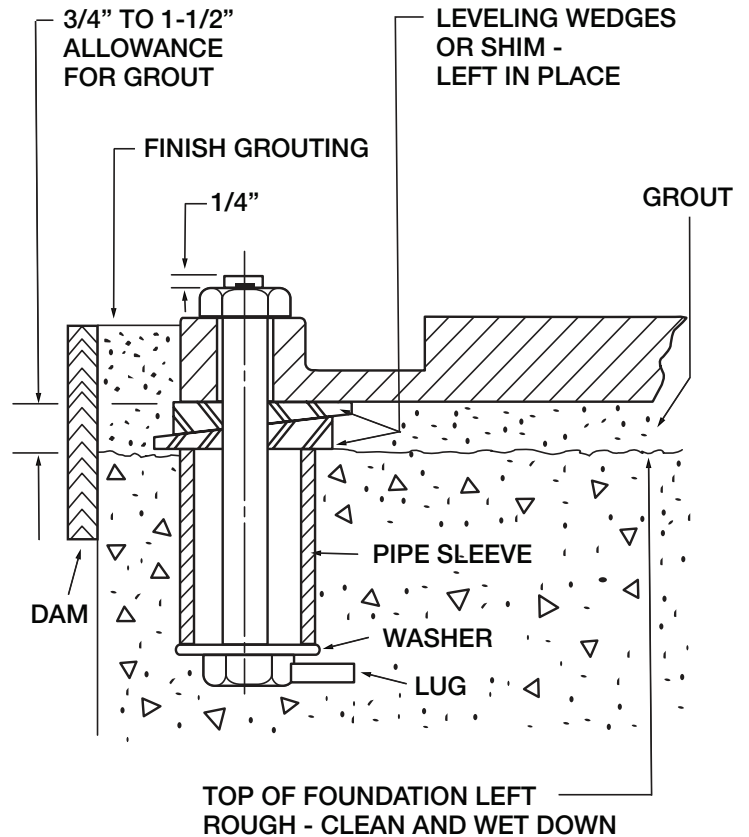

FIGURE 7 – Anchor Bolt Installation

2. Level the pump base plate assembly. If the base plate has machined coplanar mounting surfaces, these machined surfaces are to be referenced when leveling the base plate. This may require that the pump and motor be removed from the base plate in order to reference the machined faces. If the base plate is without machined coplanar mounting surfaces, the pump and motor are to be left on the base plate. The proper surfaces to reference when leveling the pump base plate assembly are the pump suction and discharge flanges. **DO NOT** stress the base plate. Do not bolt the discharge flanges of the pump to the piping until the base plate

foundation is completely installed. If equipped, use leveling jackscrews to level the base plate. If jackscrews are not provided, shims and wedges should be used. Check for levelness in both the longitudinal and lateral directions. Shims should be placed at all base anchor bolt locations, and in the middle edge of the base if the base is more than five feet long. Do not rely on the bottom of the base plate to be flat. Standard base plate bottoms are not machined, and it is not likely that the field mounting surface is flat.

3. After leveling the base plate, tighten the anchor bolts. If shims were used, make sure that the base plate was shimmed near each anchor bolt before tightening. Failure to do this may result in a twist of the base plate, which could make it impossible to obtain final alignment. Check the level of the base plate to make sure that tightening the anchor bolts did not disturb the level of the base plate. If the anchor bolts did change the level, adjust the jackscrews or shims as needed to level the base plate. Continue adjusting the jackscrews or shims and tightening the anchor bolts until the base plate is level.

4. Grout the base plate. A non-shrinking grout should be used. Make sure that the grout fills the area under the base plate. After the grout has cured, check for voids and repair them. Jackscrews, shims and wedges should be removed from under the base plate at this time. If they were to be left in place, they could rust, swell, and cause distortion in the base plate.

5. Run piping to the discharge of the pump. There should be no piping loads transmitted to the pump after connection is made.

## EXISTING GROUTED BASE PLATES

When a pump is being installed on an existing grouted base plate, the procedure is somewhat different from the previous section NEW GROUTED BASE PLATES.

1. Mount the pump on the existing base plate.
2. Level the pump by putting a level on the discharge flange. If not level, add or delete shims between the foot piece and the bearing housing.
3. Run piping to the discharge flange of the pump. (Step 5 above)

All piping must be independently supported, accurately aligned and preferably connected to the pump by a short length of flexible piping. The pump should not have to support the weight of the pipe or compensate for misalignment. It should be possible to install suction and discharge bolts through mating flanges without pulling or prying either of the flanges. All piping must

be tight. Pumps may air-bind if air is allowed to leak into the piping. If the pump flange(s) have tapped holes, select flange fasteners with thread engagement at least equal to the fastener diameter but that do not bottom out in the tapped holes before the joint is tight.

## GENERAL PRECAUTIONS

Cleanliness is essential for a good installation. Threads and other mating surfaces will not function as required if they are not clean when assembled.

Make certain that no rags, wood scraps or other foreign material is lodged in any exposed openings.

Keep the well opening covered whenever possible to prevent dropping small parts, tools, or any other foreign material into the well.

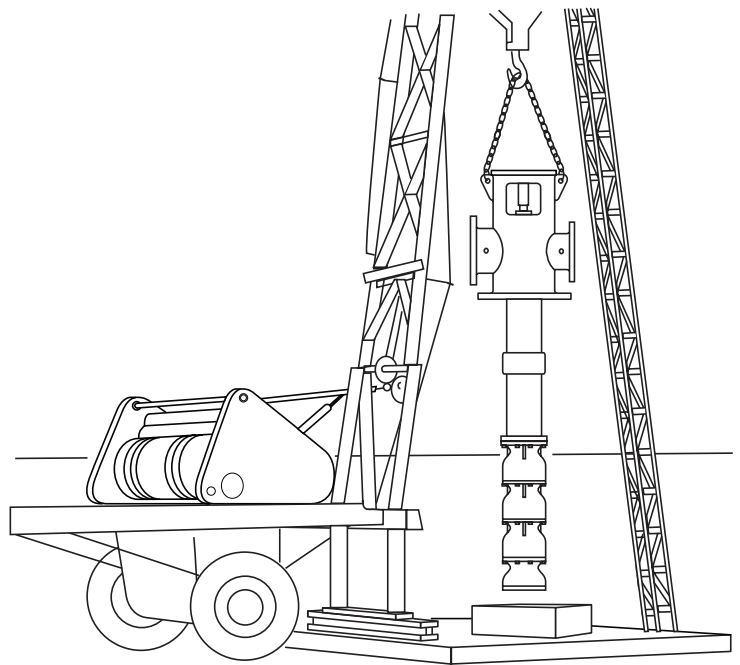

FIGURE 8 – Short Set Installation

Lift and handle the unit carefully to prevent damage caused by excessive strain being imposed on any part.

Do not allow pipe compound, solvent or any petroleum products to come in contact with rubber bearings.

**NEVER USE THREAD COMPOUND ON LINE SHAFT THREADS OR SHAFT COUPLINGS.** (Use anti-seize compound on stainless steel shaft and coupling threads.)

Always use anti-seize compound to prevent galling of the threads on steel column joints, stainless steel fasteners and stainless steel shaft couplings.

Never use gaskets between flanges, column joints, flange-to-bowl connections or head connections.

Special care must be taken to prevent damage to the threads and end faces of shafting, column pipe and tubing.

Exercise special care when handling parts which have special coatings. If the coating is damaged (nicks, scrapes, wrench marks, etc.), the damaged spots should be repaired before the installation is completed.

If during installation the pump is observed to bind or will not rotate freely on the hook swivel, then either there is an obstruction in the well or the well is crooked. In either case, the well is not acceptable for a proper pump installation and continuing with the installation will void the warranty.

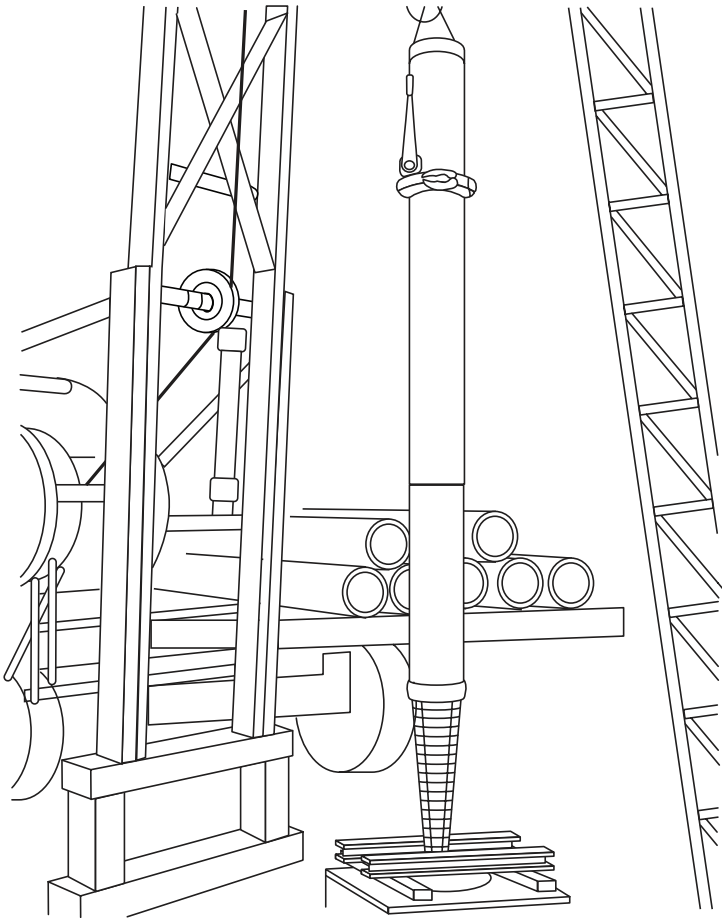

FIGURE 9 – Deep Set Installation

## INSTALLING THE PUMP FACTORY ASSEMBLED UNIT

You're now ready to start actual installation. Clear the work area at and around the mounting position so installers can move freely and with maximum safety. This will also decrease the chances for foreign material or objects to enter the pump as it is lowered into position and secured. If this is a suction cased unit, clean the top flange of the suction vessel and install the gasket or O-ring provided. Examine the vessel and be sure it has been completely cleared of all trash and debris.

During the course of the work, you must never lose sight of the fact that you are handling precision components no matter how awkward they may be to manipulate. All threads should be engaged by hand and checked before tightening. Damage resulting from cross threading or dirt must be repaired with a file before applying force. If not repairable, the part must be replaced so it's clearly worth your while to use the utmost care.

If your pump was shipped not assembled due to its length or space limitations, skip over to the section on assembly of pump components.

With a sling around the lifting trunnions on the discharge head, raise the entire unit as shipped to a vertical position over its mounting base. Take care to avoid putting any strain on the column or any exposed shafting. Also be careful not to damage the strainer during the lifting operation. Clean the bottom of the pump base and lower the assembly gently into place in its operating position with full contact, base to mounting surface. Assemble base or flange mounting bolts and/or nuts.

Examine the position of the pump. The suction bell must hang the proper distance from the bottom and be unobstructed in any direction. Piping connections must be in the right orientation with respect to jobsite plumbing.

## PARTS PREPARATION AND CLEANING

Prior to mating up threaded column joints, remove the thread protectors and thoroughly clean threads with wire brush and solvent. If necessary, repair any damaged threads with a three cornered file and remove any burrs. **THE PROTECTIVE COATINGS ON THE PARTS IS A RUST PREVENTATIVE AND IS NOT SUITABLE AS A THREAD LUBRICANT. THIS COATING MUST BE CLEANED OFF THREADS.**

Clean all shafting and couplings using a rag soaked with solvent.

Make certain that all bearings are clean (do not use solvent on rubber).

Remove rust preventative from all flange faces with solvent and if necessary, smooth the flange face with a flat file.

If tubing is furnished, check the tube ends for nicks, burrs, etc. Sections of tubing which were assembled at the factory should be checked for tightness.

Check the shaft ends for nicks, burrs, etc. The shaft ends at each coupling must butt squarely against each other in order for the shaft to be aligned properly. Check all loose shafting for straightness using "V" blocks and a dial indicator, as follows:

Do not attempt to check shaft straightness in direct sunlight. Place the shaft in "V" blocks. Rotate the shaft and observe the dial indicator. The dial indicator should not vary more than 0.001" times the number of feet to the nearest "V" block. Checks should be made at approximately 2 ft. intervals along the shaft. If necessary, the shaft can be straightened by applying a load on the high side of the shaft at the point on the shaft having the greatest deviation from the allowable values. The shaft must meet the above conditions after all straightening has been performed. Therefore, if straightening is required, the positions checked prior to the straightening operation must be rechecked.

Check the runout of the impeller shaft extension by placing a dial indicator toward the outer end of the shaft and turning the shaft slowly making certain that it stays to one side of the uppermost bowl bearing. The indicator reading should not vary by more than 0.002" as the shaft is turned (.002 TIR).

Measure and record the pump lateral (shaft end play). This information will be required when making lateral adjustments outlined later.

Remove the stuffing box from the pump head. Check that the base plate fits the foundation properly.

## INSTALLING THE PUMP FACTORY UNASSEMBLED UNIT

The pump must be equipped with enough column pipe to assure that the bowls remain submerged during operation. **THE FACTORY DOES NOT RECOMMEND OR GUARANTEE SATISFACTORY OPERATION WITH A SUCTION LIFT.** It is desirable to determine the pumping level of the well prior to installation of the pump so that the pump can be provided with the proper amount of column.

The well should be developed and test pumped prior to installation of the permanent pump. Sand should not be pumped with the pump intended for permanent installation. **PUMPING SAND OR OTHER ABRASIVES VOIDS THE WARRANTY.**

## BASEPLATE

### DEEP SET VERTICAL TURBINES

If the pump is to be equipped with a base plate, the base plate can be installed separately or it can be installed as an integral part of the head. Installing the base plate separately as outlined below is generally preferred since this method allows using the base plate as a working surface for the friction clamps or elevators.

Assure that the strainer, bowl assembly and column assembly will pass through the opening in the base plate. If these parts of the pump will not pass through the base plate, then the base plate must be installed as an integral part of the head.

- Note that if the strainer, bowl assembly, and column will not pass through the base plate, this will complicate service and maintenance operations which require the pump to be pulled out of the well. Each time the pump is pulled, the base plate will have to be removed and then realigned and re-grouted when the pump is reinstalled. If the strainer, bowl assembly and column will pass through the base plate, then the base plate (and therefore the alignment) need not be disturbed when the pump is pulled.

Place the two setting beams on the base plate. Use plywood under the beams to protect the machined surface of the base plate.

If the base plate is to be installed as an integral part of the head, proceed as follows:

Same as step above.

Place the setting beams directly on the foundation in an approximately level position.

### SHORT SET VERTICAL TURBINES

Accurate base plate leveling and alignment is the key to proper pump installation and optimum pump operation. Proceed with extreme care.

Place base plate over anchor bolts and allow to rest on at least 4 wood or metal spacers about 1/4" thick.

Place a minimum of 8 wedges, two per side, around base plate and force in until they are tight. Check level of base plate with a machinist's level and carefully hammer in wedges until plate is level within 0.003 thousands of an inch in all directions. If the elevation of the plate is critical, this should be taken into account prior to and during leveling.

Attach hex nuts to anchor bolts and tighten against base-plate.

Mix up a sufficient quantity of rather dry non-shrink grout. Force as much grout under base plate as possible. If grout holes are provided, grout can be pressure fed thru the grout holes until all cavities are filled. Grout around the perimeter of the base plate to hide the wedges. Recheck level of plate then do not disturb until grout has completely set.

## SUCTION PIPE AND STRAINER

If the overall length of the assembled strainer, suction pipe and bowl assembly does not exceed the maximum hook height of the derrick or hoist, the suction pipe can be assembled to the bowl while they are on the ground. The bowls and suction pipe can then be installed as one unit per the instructions given in BOWL ASSEMBLY on page 15. If the travel of the derrick or hoist being used is not sufficient, it will be necessary to install the suction pipe and bowl assembly separately, as follows:

Attach a pipe clamp to the upper end of the first piece of suction pipe (with strainer attached, if strainer is required), as shown in Figure 9.

Attach a sling to the clamp and hoist the pipe and strainer assembly to the vertical position taking care not to damage the strainer. Push the bottom of the pipe away from the well opening and tap the side of the pipe to remove any loose matter.

Center the suction pipe and strainer assembly over the well opening and carefully lower it until the clamp ears are resting squarely on the setting beams. Remove the sling.

Apply thread compound to the exposed threads.

If there are no additional sections of suction pipe, proceed with the installation of the bowl assembly as described in BOWL ASSEMBLY on page 16. If there are additional sections, install the clamps and sling to the next section to be installed, hoist it to the vertical position, then slowly lower the hoist and screw the pipe into the coupling. Using chain tongs, tighten the pipe connection securely. Remove the chain tongs, raise the hoist slightly, remove the clamp from the lower piece of pipe, secure the airline (if required) to the upper piece of pipe, and slowly lower the assembly until the upper clamp is resting on the setting beams. Repeat the above until all of the suction pipe has been installed.

## BOWL ASSEMBLY



# CAUTION

*Do not lift or handle the pump bowl by the shaft.*

1. Inspect the bowl assembly as follows:

- Make sure no rags, wood or other foreign material is in the suction or discharge.
- Rotate the impeller shaft to make sure it does not bind.
- If the discharge nozzle has bleed ports (used if enclosed line shaft type column is to be used), make sure that these ports are free of obstructions.
- Measure and record the available pump lateral (impeller shaft end play) if not already done.

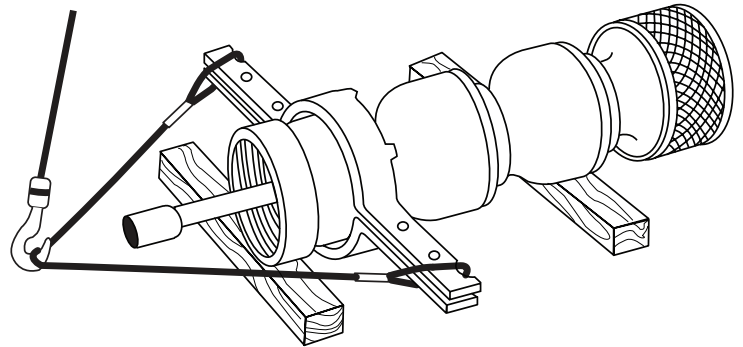

FIGURE 10 – Attaching Lifting Sling (Short Set)

2. If not already installed, place the two setting beams on the foundation (or base plate).
3. Install a friction clamp to the upper end of the bowl assembly beneath a convenient shoulder. Attach a cable sling to the friction clamp far enough out on the ears to allow removal of the sling after the friction clamp is resting on the setting beams. Also, make sure that the sling is long enough for the load hook to clear the shaft when the bowl assembly is up righted. See Figures 10 and 11. Care must be taken to prevent the cable from wrapping around the shaft to prevent the bending of shaft or oil tubing.
4. Hoist the bowl assembly to a vertical position being careful not to damage the pump suction or strainer. Use a rope to tail in the bowl assembly preventing it from swinging into the suction pipe, foundation or derrick.

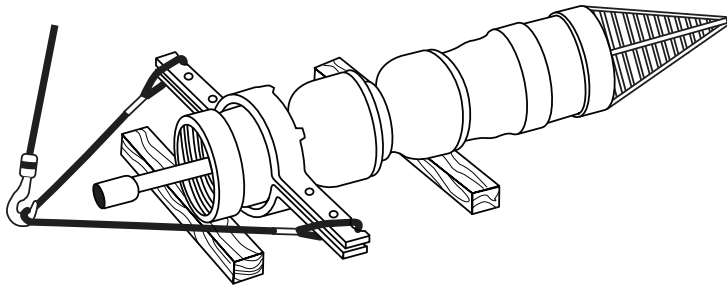

FIGURE 11 – Attaching Lifting Sling (Deep Set)

5. If the suction pipe was installed apply thread compound to the threads of the suction pipe and then carefully lower the bowl assembly so that the suction pipe engages with the suction nozzle. Screw the bowl onto the suction pipe by hand, assuring that the connection is properly aligned and is not cross threaded. Use chain tongs to tighten the connection. After the connection is tightened, raise the pump slightly, remove the friction clamps from the suction pipe and lower the unit until the friction clamp around the bowl rests on the setting beams. Remove the sling.

6. If the suction pipe and bowl assembly are being installed as one unit, center the unit over the installation opening then carefully lower it until the clamp ears are resting on the setting beams. Remove the sling.

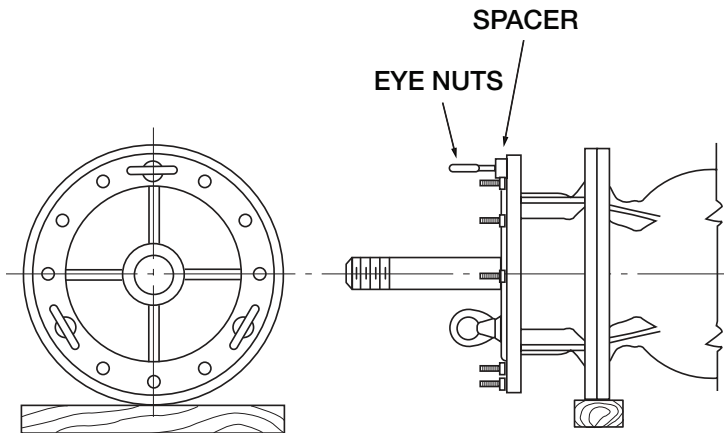

FIGURE 12 – Slinging With Eye Nuts

7. On oil lube pumps check that the exposed bearing box is tight.

8. Remove the shaft coupling, clean the shaft and coupling threads, the bowl assembly threads and butt face, and the main bearing box threads and face (if enclosing tubing is furnished). Lightly oil the shaft threads and screw the shaft coupling on half way. Place a rag over the coupling to prevent entrance of trash when installing the first section of column.

## LARGE BOWL ASSEMBLIES

Place the two setting beams on the foundation (or base plate) opening. If a base plate is used, place cardboard or thin plywood beneath the beams to protect the machined surface.

Attach the three spacers and three eye nuts to three studs about 120 degrees apart. Attach 3 legs of the 4 leg sling to eye nuts. See Figure 12.

If the bowl is equipped with a strainer, first remove strainer, hoist bowl to vertical position being careful not to drag suction across floor, then reinstall strainer.

If there is any auxiliary piping to the tail bearing, make certain that the bowl portion is assembled to the bowl at this time.

Center bowl over installation opening then carefully lower until the underside of the top flange is resting squarely on the setting beams. Remove sling, eye nuts and spacers.

Clean the shaft threads, the discharge threads and butt face or flange face and the tube adapter threads and face if enclosing tubing is furnished. Lightly oil the shaft threads and screw coupling on half way. Place a rag over the coupling to prevent entrance of foreign matter during the next step in assembly.

## COLUMN-OPEN LINESHAFT

Assemble open line shaft column as follows.

Determine the correct sequence of installation of the column sections. Refer to the Installation Plan. The top and bottom sections may be special lengths and the top section has welded lugs approximately two feet from the top end.

Secure a friction clamp immediately beneath the column coupling (if column is flanged, secure the clamp about 6" below the bottom of the flange) on the first section of column to be installed. See Figure 13.

Screw a shaft coupling onto the upper end of the shaft to protect the shaft threads and face while sliding it into the column pipe (on smaller column sizes where there is not enough clearance to allow removal of the shaft coupling after the shaft is in the pipe, wrap a rag around the end of the shaft). Slide the shaft into the column pipe until it protrudes approximately 12" past the bottom end of the pipe. Remove the coupling (or rag) installed above. Make certain that shaft sleeve, if furnished, is toward the upper end of the pipe. Tie a series of half hitches to the column pipe and to the shaft with a 3/4" rope, so as to prevent the shaft from sliding out of the column pipe when the assembly is hoisted to the vertical position.

Attach a sling to the clamp ears. See Figure 13. Screw a shaft coupling onto the lower end of the shaft to protect the shaft face



and threads in case the shaft slips during handling.

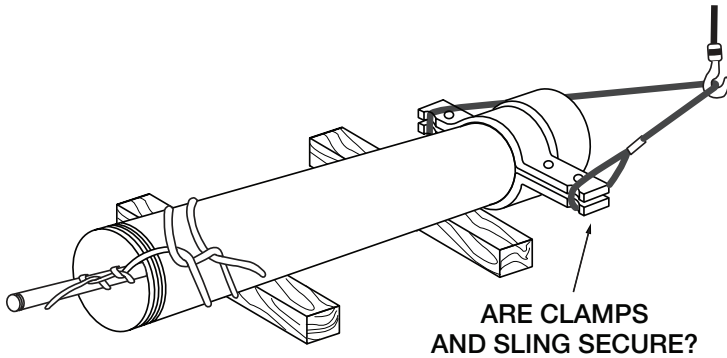

FIGURE 13 – Attaching Lifting Sling

Hoist the column assembly to the vertical position taking care not to strain the shaft or damage the shaft or pipe threads. The shaft should be supported by hand or with a pipe wrench to prevent it from slipping. Before centering the column assembly over the bowl, tap the side of the column pipe to remove any loose matter.

Swing the column assembly over the bowl, remove the extra shaft coupling from the lower end of the shaft being installed, align the shafts, remove the rag from the shaft coupling on the bowl and lower the column assembly until the shaft contacts the coupling, then remove the rope. Hold the coupling and turn the shaft by hand (left hand threads) until the shaft ends butt. **DO NOT FORCE THE SHAFT INTO THE COUPLING.** If the shaft will not screw into the coupling by hand, the threads are either damaged or dirty, or the shafts are not properly aligned. This problem must be corrected before proceeding. Place one pipe wrench on the coupling and one on the top piece shaft and tighten. Both wrenches should be handled by one man so that the push on one wrench will be balanced by the pull on the other wrench. See Figure 14. The shafts should show equal amounts of threads above and below the coupling, indicating that the shaft butt is centered in the coupling. Remove any wrench marks from the shaft and the coupling with a flat file and emery cloth. Cover the opening with a rag to prevent the metal filings from falling on bearings below.

If the bowl to column connection is threaded, apply thread compound to the bowl (pipe coupling on subsequent sections) assembly threads and butt face and to the pipe threads. Lower the column (making certain that on combination type couplings with integral spiders the shaft feeds smoothly through the bearing in the spider) until the column engages the bowl adapter. Using chain tongs, tighten the pipe into the bowl while slowly lowering the derrick hoist. Tighten the pipe into the bowl so that it seats securely against the mating shoulder in the bowl. See Figure 14.

SHAFT THREADS  
ARE LEFT HAND!

TUBING THREADS  
ARE RIGHT HAND!

PIPE THREADS  
ARE RIGHT HAND!

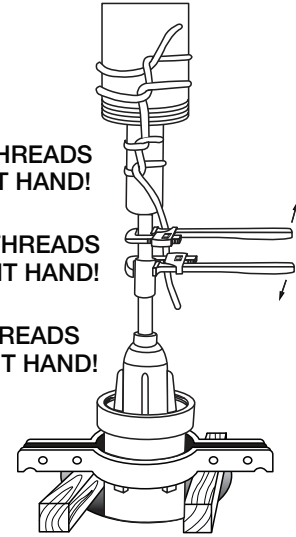

FIGURE 14 – Tightening Line Shaft

If the bowl to column connection is flanged, spread a thin even film of thread compound on the bowl discharge flange. Lower the pipe, align the studs in the bowl with the holes in flanges, seat the column flange against the bowl flange, and then install and tighten the hex nuts evenly. If a lubrication line is being installed, secure the line to the column pipe just above the column pipe joint.

Hoist the unit slightly, remove the bowl clamp and slide the setting beams out enough to allow passage of the unit.

If the bowl and column are coated with any special application, any required touch up work should be done before lowering the unit.

Lower the unit, slide the setting beams in close to the column and continue lowering the unit until the clamp ears rest on the setting beams. Remove the sling. If an airline is being installed, be careful not to crush or otherwise damage it as the unit is being lowered.

If a separate spider is used, clean the flange recess and the spider ring O.D. and faces thoroughly, slip the spider over the shaft and seat it in the flange recess or coupling I.D. Since threaded compound dries fairly quickly, wait until the next column section is in the vertical position and the shaft connection is made, then apply thread compound to both flange faces or coupling I.D. and to the butt faces of the spider.

Check that the shaft sleeve is approximately centered in the bearing. Move the shaft around slightly so as to center it in its bearing. Only a slight amount of force should be required. If an excessive amount of force is required the pipe or shaft may not be butted properly or the shaft may be bent. In any case, the trouble must be corrected prior to proceeding further.

Remove the exposed shaft coupling, clean the coupling threads

and the shaft threads and face thoroughly. Thread the coupling on for half its length. Cover the coupling with a rag to prevent entrance of foreign matter.

Repeat the above outlined procedure for each additional section of column until all of the column has been assembled. Two welded lugs are provided on the O.D. of the top section of column pipe. The friction clamp should be installed immediately under these lugs. Clean the top column flange face (or end of pipe if head connection is threaded) and the shaft projection thoroughly. Do not assemble the shaft coupling to the top piece of shaft.

## COLUMN-ENCLOSED LINESHAFT

Assemble enclosed line shaft column as follows.

Determine the correct sequence of installation of the column sections. The top section of column has welded lugs approximately two feet from the top end. The top special tubing is tagged for identification by the factory. If this tag is lost, the top special tubing can still be identified by the smooth O.D. and chamfer on one end. This end also has longer threads inside the tube.

Secure a friction clamp immediately beneath the coupling on the first section of column to be installed. If the column is flanged, secure the clamp about 6" below the bottom of the flange. See Figure 15.

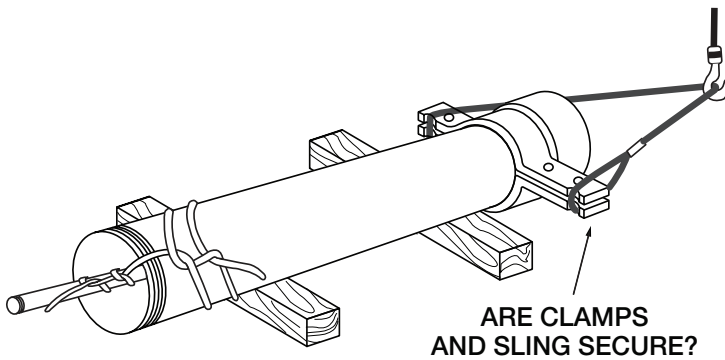

FIGURE 15 – Securing And Slings Column & Shaft

If the protective rubber cap has been removed from the end of the tubing to be inserted in the pipe, reinstall it. Slide the tubing and shaft assembly into the lower end of the pipe, allowing the tubing to protrude about 15" past the lower end of the column pipe and allowing the shaft to protrude about 9" past the end of the tubing. See Figure 16. If the tubing is 5" or larger, ensure that the end with the machined section goes toward the top. Tie a series of half hitches to the pipe tubing and shaft with a 3/4" rope so as to prevent the shaft and tubing from sliding out of the pipe when the assembly is hoisted to the vertical position. Attach a sling to the clamp ears. See Figure 16.

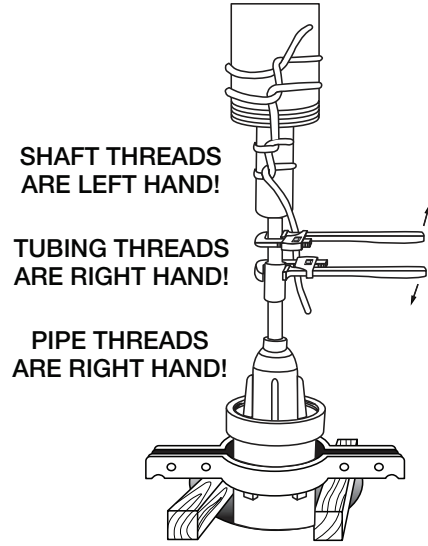

FIGURE 16 – Tightening Line Shaft

Hoist the column to the vertical position taking care not to strain or damage the shaft. The shaft and tubing should be supported by hand or with two pipe wrenches to prevent slippage. Before centering the column over the bowl, tap the side of the column to remove any loose matter from the pipe.

Make up the shaft joint as described in COLUMN on page 17.

Lower the assembly until the tubing contacts the main bearing box (line shaft bearing on subsequent sections) and then remove the rope. Apply a small amount of thread compound to the outside diameter of the exposed bearing threads. Place one pipe wrench on the main bearing box shoulder (place wrench on lower piece of tubing on succeeding column joints) and the second wrench on the tubing and tighten firmly. If the tubing is coated with any special application, any touch up required resulting from using the pipe wrench should be done now.

After each piece of column has been lowered and is resting on the setting beams, remove the exposed line shaft bearing, pour oil into the tubing and reinstall the bearing. This is not necessary if the unit is to be force water lubricated. The amount of oil to be poured is given in the table below.

TUBE SIZE	AMOUNT OF OIL PER SECTION	
	10 FOOT SECTION	20 FOOT SECTION
1-1/4, 1-1/2, 2	½ CUP	1 CUP
2-1/2, 3, 3-1/2	1 CUP	½ QUART
4 and Larger	½ QUART	1 QUART

TABLE 1

If the column is threaded and utilizes sleeve construction (steel coupling and separate rubber spider), clean the tubing O.D.,

slip the spider over the tubing, and force it approximately 2” into the pipe. The spiders should be located approximately 20’ from the bowl and from the head and at 40’ intervals along the tubing. The spiders should fit snugly in the column pipe or on the tubing (or both places), otherwise they will slide to the bottom of the well. If the column is flanged, clean the flange recess and O.D. with a file to remove any foreign matter, nicks and burrs. Since thread compound dries fairly quickly, wait until the next column section is in the vertical position and the tubing connection has been made before applying to column coupling threads or flange faces if fabricated column is used.

Repeat the procedure outlined above for each additional section of column until all of the column has been assembled.

Special precautions for sleeve type column.

Because of the tendency of the threads to gall when steel pipe is screwed into steel couplings, the following special precautions should be taken when assembling sleeve column.

- Inspect and thoroughly clean the coupling threads (on the section set in the well) and repair any damaged threads as required. Liberally coat the threads with anti-seize compound (NOT thread compound).
- Before centering the column assembly over the installation opening, clean, inspect and repair any damaged threads.
- Recheck pipe threads for cleanliness or damage after pipe is hoisted to vertical position, and then apply a liberal coat of anti-seize compound to the threads.
- When lowering the pipe into the coupling, do not back thread the pipe.
- Align the coupling and pipe threads using a straight edge about 3 to 4 feet long. Lay the straight edge vertically against the coupling O.D. Align the pipe so that the distance between the pipe and the straight edge is equal along the full length of the straight edge in two positions 90° apart (i.e. until the pipe is parallel to the straight edge).
- Carefully screw the pipe into the coupling as far as possible by hand. Do not use a power driven mechanism to spin the connection together. If at any time the threads are suspected of galling, unscrew the pipe and inspect, clean and repair as necessary the pipe and coupling threads. Apply a fresh coat of anti-seize compound and repeat the above assembly procedure exercising special care in aligning the pipe with the coupling.

## DISCHARGE HEAD

If a steel lifting plate is provided for use under the discharge head and this plate is not already attached to the head, attached the plate as described below.

### SIMPLE LIFTING PLATE

- Clean the mating surfaces of the head and the lift plate.
- Place the head on the plate. Orient the head so that the holes (including any auxiliary holes) in the head line up with the holes in the plate.
- Bolt the head to the plate by installing two bolts in diagonally opposite holes in the base of the head.

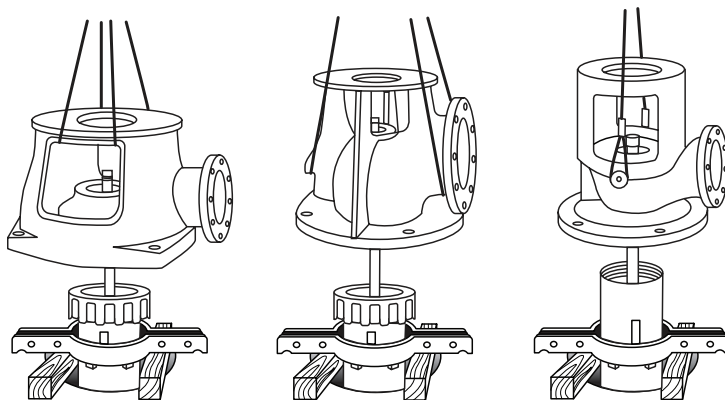

FIGURE 17 – Assembling Pipe Head to Column Pipe

### FULL LIFTING PLATE

- Install studs in the threaded holes near the large hole in the plate. Drive the studs into the plate as deep as the threads will allow. Also assure that the stud protrudes from the same side of the lifting plate as the female register.
- Clean the mating surfaces of the head and the lifting plate and install the O-ring.
- Place the discharge head on the lifting plate. Orient the head to the desired position, making sure that the auxiliary holes in the head line up with the auxiliary holes in the plate.
- Install the socket head cap screws provided to secure the plate to the head.

If a top column flange is to be used and it is not already installed, install it on the top section of column pipe as follows:

### BUTT TYPE FLANGE

- Clean the pipe and flange threads and butt surfaces and apply a thin coat of thread compound.

Screw the flange onto the pipe and tighten securely.

## ADJUSTABLE TYPE FLANGE

- Clean the threads on the column pipe, the flange and the packing ring.
- Screw the packing ring onto the pipe. Make sure that the chamfer is on top.
- Screw the flange onto the pipe.

Attach slings to the head for lifting as shown in Figure 17 which ever is applicable.

Lift the head (and lifting plate if used), remove the hex nuts from the studs (if studs are used), and clean the mating surfaces on the bottom of the head (or lifting plate) and on the column pipe. Apply a thin coat of thread compound to all of the head-to-column mating surfaces.

If the head-to-column pipe connection is flanged, align the head with flange holes, lower the head until it is seated squarely on the flange, and then install and tighten the fasteners. If a butt type flange is used, orient the head so that its outlet is as close as possible to its final position.

If the head-to-column pipe connection is threaded, lower the head until it contacts the pipe, apply a set of chain tongs to the pipe and turn the head until the pipe seats. To tighten the head further, place a long pipe through the head windows or into the discharge (being careful not to damage the shaft).

## ALIGNMENT

In order to prevent undue bearing loads and excessive vibration, the pump head and line shaft must be aligned properly and must remain aligned during operation. The pump head should be placed at the approximate elevation desired by shimming equally under the wedges installed in RECOMMENDED PROCEDURE FOR BASE PLATE INSTALLATION on page 11, if necessary, and the discharge flange should be oriented properly (this is limited if anchor bolts are used) prior to commencement of the head alignment. Once the head has been aligned, any connections made must be fitted so that no strain is placed on the pump head when the connections are tightened. **DO NOT ATTEMPT TO ALIGN THE HEAD WITH THE DISCHARGE PIPING CONNECTED.** When properly aligned the line shaft will be in the center of the head and will be perpendicular to the driver mounting flange on the head. The alignment should be performed as described below.

Remove the stuffing box (if installed). Using calipers, check the distance “R” between the shaft O.D. and the stuffing box bore of the head in four places approximately 90° apart. If these distances are all equal, the shaft is properly centered. If not, the shaft must be centered by shimming between the foundation

and the base plate until these distances are equal. This is done by loosening the anchor bolts driving in the wedges or inserting shims under the side where the shaft is farthest from the bore and withdrawing the wedges or removing shims from the side where the shaft is closest to the bore. Tighten the anchor bolts and check to see that the shaft remains centered.

Install the drive shaft or a short dummy shaft. Using a carpenter’s square, determine whether or not the shaft is perpendicular to the motor mounting flange. Check four places 90° apart. If the shaft is not perpendicular, adjust the wedges as described above. (A bent carpenter’s square will give a false indication. If the direction of indicated out of perpendicularity changes as the square is shifted between positions 180° apart, then the square is bent.) After adjusting the wedges, check that the shaft is still in the center of the stuffing box bore.

Rotate the shaft approximately 90° and repeat the two above steps.



*The shaft can be turned on shallow settings by temporarily installing the stuffing box (without packing rings, etc.) connecting a dummy shaft (not necessary if line shaft to head shaft connection is below the stuffing box) and turning the shaft with a wrench. Remove the stuffing box prior to doing any alignment checks.*

On deeper settings it will be necessary to connect a lifting device such as shown in Figure 5 to the upper end of the shaft and then carefully raise the shaft and impellers using the hoist on the derrick. A wrench can then be used to turn the shaft. Lower the hoist and remove the lifting device prior to doing any alignment checks.

When a wrench is to be used on a shaft that is a permanent part of the installation, wrap the shaft for protection.

If the shaft did not remain in the center of the stuffing box or did not remain perpendicular to the motor mounting flange, then it is likely that either the top shaft is bent or the first shaft joint below the head is not installed properly (not butted, trash or burrs on butt faces, etc.). In order for the alignment to be acceptable the shaft must remain in the center of the stuffing box bore and remain perpendicular to the motor mounting flange for two shaft positions 90° apart.

Note that the discharge head may not be exactly level when the alignment is completed. This is normal and **NO ATTEMPT SHOULD BE MADE TO LEVEL THE DISCHARGE HEAD.** The head is aligned so that the shaft will run true in the stuffing box bearing (i.e. head is aligned perpendicular to the

shaft). If the well is drilled at a slight angle then the pump may lay against one side of the casing, resulting in the column pipe and shaft laying at a slight angle away from vertical. When the head is aligned to this shaft it also will sit at this same angle.

## STUFFING BOX

### OPEN LINE SHAFT

Remove any paint and burrs from the underside of the machined flange of the stuffing box and from its mating surface on the pump head. Remove the lantern ring and separator rings which are shipped in the bottom of the stuffing box cavity.

Slide the stuffing box over the shaft and orient it so that its ports are in the position desired. Hold the stuffing box off its mating surface on the head and apply a liberal amount of thread compound to the head. Lower the stuffing box into position and bolt it down firmly in place with cap screws. If it is necessary to push the shaft sideways in order to get the stuffing box register to go into the bore, then the head is not properly aligned.

Complete assembly of the stuffing box per the “Stuffing Box Assembly” instructions in your Owner’s Manual pack. Retain these instructions for reference when repacking the stuffing box.

### ENCLOSED LINE SHAFT

Complete assembly of the stuffing box per the “Stuffing Box Assembly” instructions (furnished with your Owner’s Manual packet).

## DRIVER AND DRIVE COUPLING

Uncrate the driver but leave it attached to the bottom skid on which it arrived. Move it to a convenient location beside the pump head, keeping it vertical at all times. Set down on firm and level footing.

When ready for installation, raise the driver off its skid to a comfortable working height, lifting it with the lugs provided on the frame.



*Don't work under the load while it's hanging from the hoist. Clean the top of the pump head and inspect it also, making any necessary repairs.*

If your pump is equipped with a vertical hollow shaft driver, illustrated in Figure 21, continue right on here with subsection Vertical Hollow Shaft. If you have a solid shaft driver as in Figure 22, skip this portion and be guided by subsection Vertical Solid Shaft.

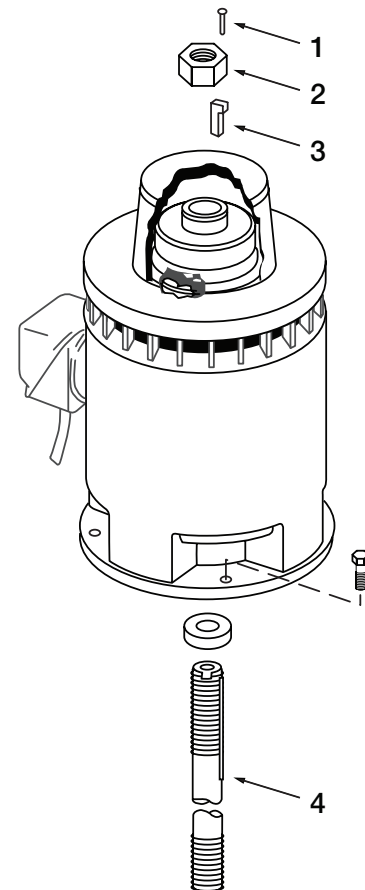

FIGURE 18 – Vertical Hollow Shaft Motor

## VERTICAL HOLLOW SHAFT

Remove the driver cover cap screws and the canopy itself, as in Figure 19. Remove the drive coupling and any other parts packed in the top for shipment. Place them in a clean, safe place for later use. Cover all openings in the top to prevent anything from dropping into the driver. If this should happen, the object must be retrieved before proceeding.



*Stand beside the load as it hangs in the sling, never under it. Inspect and clean the mounting flange and register. If you find any burrs or nicks, set the driver on two beam supports and repair with a file.*

Lower the driver slowly to the head until the register fit is engaged, but with the weight still on the hoist. In the case of an electric motor, swing it around so the junction box is in the desired orientation. If you have a gear drive, as depicted in Figure 20, your positioning criterion is the horizontal input shaft. Align the mounting holes and start the attaching cap screws in by hand. Transfer the weight gently from hoist to head and secure the cap screws, tightening them uniformly.

Please note that the lifting lugs on the driver are for handling the driver only. Never attempt to use these lugs to hoist the pump. The pump must be handled with its own lifting trunnions.

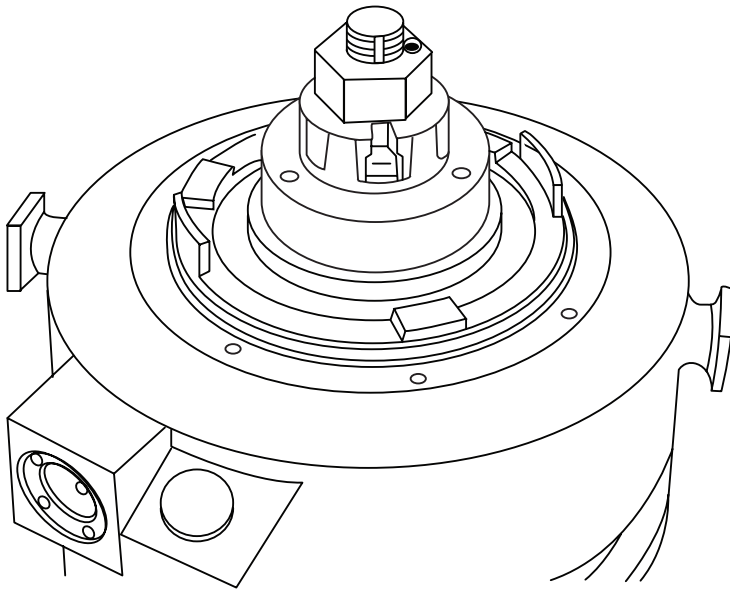

FIGURE 19 – VHS Motor Canopy Removed

If you have a VHS electric motor open the main breaker or pump disconnect switch and make a temporary connection between the motor terminals and the leads from the starter panel. Since many electric motors are built as dual voltage machines, it is important that the proper connections be made to suit the voltage of your power source. Therefore, you must check both power characteristic and motor rating for compatibility, then see the motor nameplate for correct wiring hookup.

While scanning the nameplate, determine the type of thrust bearing with which you've been furnished. If it's a spherical roller bearing, proceed with utmost caution as it must never be run at normal speed without an appreciable thrust load. For this reason, when establishing rotation as we're about to do, be very careful to just bump or tap the switch. Never close it fully until the pump is completely operational.

Otherwise, you may now energize the starter panel and buzz start the motor by switching it very quickly on and off, observing for direction of rotation and watching to see that it spins freely and is in apparent balance. Driver shaft must turn coun-

terclockwise when viewed from the top. If rotation is clockwise, kill the power to the starter panel and interchange any two leads on three phase motors. With single phase machines, follow manufacturer's instructions.

After reconnection, energize the starter and again buzz start the motor. When you're sure you have counter-clockwise rotation, mark the motor terminals and the leads from the starter box to match. De-energize the starter at the main breaker or pump disconnect switch and make the permanent power connections. Naturally, these connections must be made in accordance with all applicable electrical codes and regulations.

If your pump is equipped with a right angle gear drive, as shown in Figure 20, instead of an electric motor, the rotation check must wait until later when the pump is completely installed and connected to the prime mover. At that time, rotation is verified in a manner similar to that just described with allowances for the type of power equipment. One thing you can do right now is match up the rotation arrows on your gear and your prime mover to determine compatibility, at least as far as the nameplates are concerned.

Your heads haft was probably shipped to you in a separate box. Find it and clean it thoroughly throughout its length, threads, keyway, and end faces. Now, slide it down through the driver hollow shaft without bumping or scraping, keyway end up. If you were furnished with a slinger ring, assemble it to the shaft as the shaft bottom end emerges from the bottom of the driver.

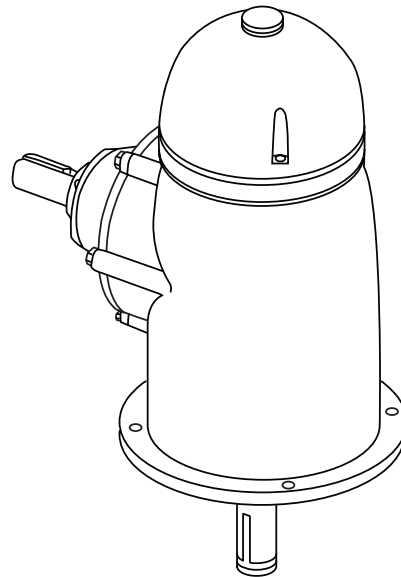

FIGURE 20 – Right Angle Gear Drive

Remove the cap screws securing the packing box or tension nut flange. The shaft coupling may be above or below the packing box/tension nut location. If above, make the connection in the usual manner, mindful of the left hand threads. If below and in the elbow itself, loosen the packing if any and continue lower-

ing the head shaft through the packing box or tension nut until you encounter the coupling below. If possible, hold the shaft coupling by reaching in through the discharge opening. In any case, start the shaft into the coupling very carefully and snap to a firm butt.

Looking down on the driver, check to see that the head- shaft stands in the center of the hollow shaft and that the driver shaft rotates freely by hand. If the shaft stands to one side of the quill, rotate the shaft from below. If the top of the bar moves around the quill, you have a bent shaft or a bad coupling joint. If, however, the shaft remains in the same off center spot during rotation, the problem is with one of the stationary parts, perhaps the column or head assembly or, just as likely, the mounting structure. Wherever it is, it must be rectified before proceeding. If in doubt, call your factory representative.

When all is well, replace the packing box or tension nut flange capscrews, tightening them uniformly and securely. Retrieve the drive coupling and other parts you set aside, together with the pump parts.

Try the drive key, Figure 18, Item 3, in both head shaft and drive coupling keyways. They should produce a sliding fit. If necessary, dress the key until a free but not loose fit is obtained. Do not file the keyways. Slide the drive coupling over the head shaft, Figure 18, Item 4, into proper position onto its register, firmly seated perfectly flat without cocking. It should slide easily and smoothly without tendency to drag or hang up when lowered or rotated.

Insert the drive key, Figure 18, Item 3. Again it should be a free, but not loose, fit. If necessary dress the key but never the keyways. The top of the key must be below the adjusting nut seat when in place.

Thread the adjusting nut, Figure 18, Item 2, onto the head shaft remembering the left hand threads, and raise the shaft until all its weight is on the nut. This is the break free point and may be recognized as that point at which the impeller can first be turned by hand. With a very slight lowering of the shaft, the impellers are felt to drag on the bowl seal rings. Mark the break free point, adjusting nut to driver coupling. Set lateral per Table 4. Assemble the lock screw, Figure 18, Item 1.

If your pump is equipped with electric drive, energize the starter and just bump the switch very lightly. With an engine or other type of drive, you must go through the entire first startup procedure, then take the unit barely up to speed and immediately release the power. This will firm up all the shaft joints. However, keep in mind our warning regarding a spherical roller thrust bearing. If your driver came equipped with one, omit this step until you can apply the full thrust of the pump to the bearing.

De-energize the starter for electric drives. Remove the adjusting nut lock screw and lower the impellers to the original break

free point as marked. Determine that this has not changed or, if it has, establish a new break free point, punch marking the nut and driver coupling for permanent reference. This would conclude your adjustment procedure for startup and early period operation of an electrically driven pump. Replace the lock screw and secure.

After completing the adjustment procedure, replace the driver canopy and secure the cap screws. Keep it that way all the time that you aren't actually working under the cover. Check driver lubricant and follow directions from manufacturer. If your driver requires provision for coolant flow, take necessary measures as instructed. Do not run equipment until all these considerations have been satisfied. Leave the power circuit open to the starter panel while performing remaining work except when it requires pump operation.

## VERTICAL SOLID SHAFT

Lower your vertical solid shaft driver to a firm and stable position atop a pair of beams or blocks placed on the discharge head to provide ample clearance between driver shaft and pump shaft. If you have an electric motor to deal with, secure it firmly against re- active torque with chain or cable restraints. Open the main breaker or pump disconnect switch and make a temporary connection between the motor terminals and the leads from the starter panel. Since many electric motors are built as dual voltage machines, it is important that proper connections be made to suit the voltage of your power source. You must check both power characteristic and motor rating for compatibility, then see the motor nameplate for correct wiring hookup.

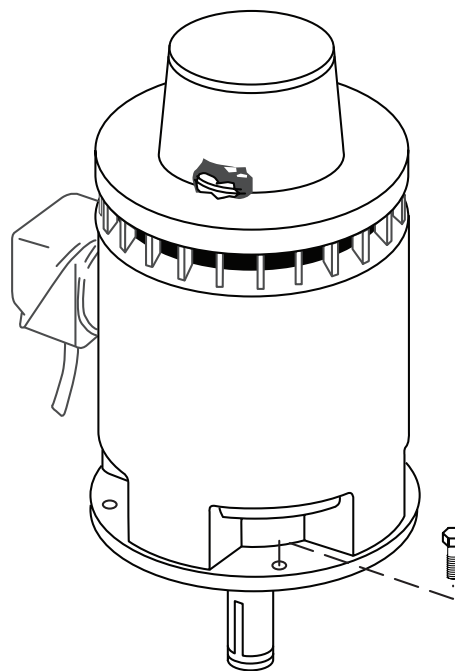

FIGURE 21 – VHS Mounting Bolts

While scanning the nameplate, determine the type of thrust bearing with which you've been furnished. If it's a spherical roller bearing, proceed with utmost caution as it must never be run at normal speed without an appreciable thrust load. For this reason, when establishing rotation as we're about to do, be very careful to just bump or tap the switch. Never close it fully until the pump is completely operational.

You may now energize the starter panel and buzz start the motor by switching it very quickly on and off, observing for direction of rotation and watching to see that it spins freely and is in apparent balance. Driver shaft must turn counterclockwise when viewed from the top. If rotation is clockwise, kill the power to the starter panel and interchange any two leads on three phase motors. With single phase machines, follow manufacturer's instructions.

After reconnection, energize the starter and again buzz start the motor. When you're sure you have counterclockwise rotation, mark the motor terminals and the leads from the starter box to match. De-energize the starter at the main breaker or pump disconnect switch.

If your pump is equipped with a right angle gear drive instead of an electric motor, the rotation check must wait until later when the pump is completely installed and connected to the prime mover. At that time, rotation is verified in a manner similar to that just described with allowances for the type of power equipment involved. One thing you can do right now is match up the rotation arrows on your gear and your prime mover to determine compatibility, at least as far as nameplates are concerned.

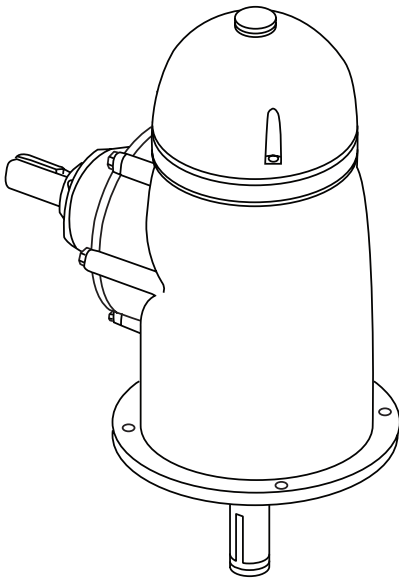

FIGURE 22 – Right Angle Gear Drive

While the driver is still sitting on the blocks, examine the protruding driver shaft for any burrs or nicks. If necessary, repair very cautiously with a small file. Clean the shaft and oil it very

lightly. Find the shaft flanged-coupling parts, and clean them all thoroughly.

Try the driver shaft key, in both driver shaft and upper coupling half keyways. You should find a very close sliding fit. If necessary, dress the key but not the keyways until you obtain a free, but not loose, fit. Now try the thrust collar in the shaft groove. It too, should be a very close fit and may be dressed to obtain this if necessary. Try the top half coupling on the shaft.

When you have the proper fits and while the driver still sits on the blocks, insert the key in the shaft keyway and slide the coupling half up on the shaft flange face down. With the flange above the drive shaft ring groove, assemble both halves of the thrust collar in the groove and slide the coupling back down until it rests firmly on the thrust collar, retaining the collar halves in place in the coupling recess. Assemble and tighten setscrew securely.

If your coupling is furnished with a spacer spool, assemble the spacer to the driver coupling half. If parts are match marked, install them accordingly. Use only the nuts and bolts shipped with the pump as some couplings are balanced as assemblies. Tighten all flange bolts securely and uniformly throughout the coupling.

Inspect and clean the pump shaft threads, painting lightly with a good thread lubricant. After trying keys and parts as described above, insert key in the pump shaft keyway and slip the pump shaft coupling half well down over shaft, flange face up, leaving shaft threads projecting above coupling. Screw adjusting nut onto pump shaft with the rimmed end up, turning counterclockwise until pump shaft protrudes through threaded portion of nut by at least two threads. Remove the cap screws securing the packing box or tension nut flange.

Raise the driver just enough to remove the blocks, then lower it slowly to the head until the register fit is engaged but keeping the weight on the hoist. In the case of an electric motor, swing it around so that the junction box is in the desired orientation. If you have a gear drive your positioning criterion is the horizontal input shaft. Align the mounting holes and start the attaching cap screws in by hand. Transfer the weight gently from hoist to head and secure the cap screws, tightening them uniformly.

Please note the lifting lugs on the driver are for handling the driver only. Never attempt to use these lugs to hoist the pump. The pump must be handled with its own lifting trunnions.

With the pump shaft all the way down so the impellers are firmly seated in the bowls, screw the adjusting nut up by turning it clockwise until the face of the driver coupling flange or spacer lower flange, if you have a spacer spool, equals the lateral setting. See Table 4. Pull the pump coupling up and insert flange bolts through both flanges. Assemble the nuts and tighten by



hand until they are snug, using a light machine oil on the bolt threads.

Check for shaft alignment at the outer edges of all the flanges. They must meet evenly both at the faces and at the outer circumferences. True alignment can be further verified by using dial indicators on both the driver and the pump shafts. If you cannot obtain an alignment within 0.003 inches T.I.R., call your local factory representative.

When satisfactory alignment is achieved, put all bolts under uniform tension, using a torque wrench. Five hundred inch pounds should be sufficient torque; i.e., a fifty pound pull on a ten inch wrench or the equivalent. Make sure pump shaft key is flush with coupling hub and tighten setscrew securely to lock the key in place.

Now replace the packing box or tension nut flange cap- screws. Tighten them uniformly and securely.

## MISCELLANEOUS EQUIPMENT

### LUBRICATING DEVICES

#### Oil Lubricated Pumps

Install the lubricator and bracket to the discharge head. Refer to the lubricator assembly drawing.

Connect the 1/4" copper line from the lubricator to the stuffing box inlet port.

#### Water Lube Pumps.

Connect the line from the pre-lube system to the pre-lube connections on the stuffing box. (Some heads have a pre-lube connection at the back of the head.) The following items should be taken in consideration for the pre-lube system.

Do not use pipe that is smaller than the pre-lube connection furnished in the stuffing box.

If the system is to be subjected to low temperatures, adequate precautions must be taken to prevent freezing.

The pre-lube system should supply a flow of water for approximately 15 seconds plus 15 sec. per 100' of column above the static water level. Pumps operating at a static water level of greater than 100 ft. and which are not equipped with a non-reverse mechanism must be post-lubricated during the time that the pump is spinning backward after it is shut down. The post lubrication should start immediately when the pump is shut down and should continue for as long as the shaft is turning. It is desirable that the post-lube be initiated automatically, so that loss of power to an unattended pump will not result in damage due to lack of post lubrication.

If automatic controls are used on the pre-lube system, the control system should be designed so that it provides maximum assurance that pre-lube (and post lube if required) is supplied when the pump needs it. Special consideration should be given to such situations as loss of electric power to the pre-lube control system without an accompanying loss of power to the driver itself. One of the most foolproof systems is a continuous running system taking its supply from a pressurized header or a large reservoir. If a tank type pre-lube system is used precautions must be taken to assure that an adequate supply of water is always available to provide the required lubrication.

The minimum pre-lube tank capacities are given in Table 2.

COLUMN SIZE	REQUIRED CAPACITY
3	10 Gal. Per 100 feet depth to static water level
4, 5, 6	25 Gal. Per 100 feet depth to static water level
8, 10, 12, 14	50 Gal. Per 100 feet depth to static water level

TABLE 2

Use 1-1/2 times the above capacity if post lube is required.

### DISCHARGE PIPING

The head and discharge pipe flange faces should be clean and free of nicks and burrs. If a grooved type flange is used, make certain that the groove is clean and free of obstructions.

Do not attempt to use a flat gasket on discharge head outlet flanges, which are not machined. These flanges are grooved to accept the square packing furnished with the head. Since these flange faces are not flat, tightening the bolts in an attempt to seal a flat gasket will usually result in a broken discharge flange.

The discharge piping should be installed and supported in such a manner as to eliminate the possibility of the head being placed in a strain. The pump head can easily be thrown out of alignment by "drawing up" the bolts in a discharge flange connection that is not "fitted up" properly.

If a flexible connection such as a Dresser coupling is to be used, a joint harness should be installed across this connection. The tie bolts for such a harness should be designed so that they do not elongate more than 0.005" when restraining the hydraulic force which tries to separate the joint. This force is equal to the discharge pressure in psi times the cross sectional area of the bore of the pipe in square inches. The tie bolts should be snugged up carefully by applying approximately the same amount of torque to each bolt, otherwise, the purpose of the coupling will be defeated.

## AIR RELEASE VALVE

Install the air release valve, piping and manual valve (if furnished), to the pump head or just beyond the head flange on the discharge piping. It is recommended that a throttling device be used on the discharge side of the air release valve to restrict the discharge of air ensuring that a cushion of air is available in the discharge head during start up. Exhausting the air too quickly can cause damage to the head.

An air release valve is imperative on water lubricated pumps with underground outlets. It eliminates trapped air in the column above the underground outlet which would cause the bearings and stuffing box to run dry.

## MISCELLANEOUS ACCESSORIES

Connect the pressure gauge, and/or gauge cock, if furnished to the tapped hole at the top of the discharge flange on the head. Position the dial face to facilitate reading.

## ELECTRICAL CONNECTIONS

All connections to the motor such as main leads, space heater leads, thermocouple leads, etc. should be made in accordance with motor manufacturer's recommendations and local codes.

Make necessary connections to lubricator solenoid if oil lubricated. Ensure that the solenoid is supplied with the proper voltage.

## AIR LINE

When required, the water level in the well can be determined by attaching a bicycle tire pump to the air valve and forcing air into the air line until the pressure gauge reading is constant. This reading (converted to ft. of water) indicates the number feet of submergence of the end of the air line. The water level in the well is determined by subtracting the amount of submergence from the known length of the air line. (The air line length was recorded during installation.)

## CONNECTING THE PIPING

You will be connecting your pump to your piping of course, since the pump is there to energize your system. Depending on details of installation, you will certainly be joining at the discharge flange and there may be a connection at the suction also. Whatever your particular system is, it must be independently supported. It must not be allowed to impose stresses on the discharge head due to weight, thermal expansion, misalignment, or any other condition.

When bolting the system flange to the pump head discharge

flange, determine that the flanges fit face to face and hole to hole before inserting bolts. Do not draw the flanges together with the flange bolts.

Above the floor piping should be installed in such a manner as to eliminate the possibility of the discharge ell (head) being placed in a strain or being thrown out of alignment.

Below ground discharge connection should be made in such a manner that no strain or misalignment is imposed on the column pipe. Alignment between the pump discharge and the outside should have already been achieved as instructed.

If a flexible joint such as a dresser coupling is to be used, sufficiently strong tie bolts and lugs should be used to span the flexible joint capable of resisting the force created by the discharge pressure at the pump head. None of this force should be imposed on the head. Tension should be taken carefully on these tie bolts so that any amount of forward movement induced to the head will be counteracted during operation so that alignment is maintained during operation.

On an underground discharge the above procedure can also be used. However, it might be more convenient to construct a simple brace from directly behind the discharge outlet to the pit wall to counteract any forces created by discharge pressure.

Flange faces should be thoroughly clean and free of all nicks or burrs and should be in perfect alignment before tightening bolts.

You may have some small pipes or tubes to accommodate if you are supplying coolant to the driver, for example. In such cases, it is well to protect the small lines from vibration by using a hose connection in strategic locations.

## STARTING THE PUMP

### INITIAL START UP

Ensure that all of the pump installation as described in preceding sections of this manual is complete.

Ensure that auxiliary equipment has been installed, serviced, and is ready for operation. Automatic control systems should have been checked per prior to making the driver-to-drive shaft connection. Automatic controls that do not function properly can cause serious damage to the pump.

Service the driver as recommended by the manufacturer.

Open the air release system isolation valve. Adjust the air release system throttling device so that it is partially open. It should not be closed or fully open. Not exhausting the air, or exhausting it too quickly can damage the pump.

On oil lubricated units, clean and fill the lubricator tank with oil meeting the specifications at the beginning of this manual. Manually open the lubricator valve and allow oil to run into the tube line for at least 20 minutes for each 100 feet of setting prior to start-up. Assure that the oil is in fact flowing into the tubing before timing is commenced and that the flow rate is at least as much as given in Table 2, Page 27. On systems equipped with a solenoid operated lubricator valve that cannot be energized independently, it will be necessary to remove the valve stem to allow the oil to flow. Replace the valve stem before starting the pump. The pump should be started shortly after allowing the oil to flow into the tube line. If the start up is delayed, the lubrication procedure must be repeated just prior to the actual on startup.

Ensure that the system to which the pump is connected is ready to receive flow from the pump. For most well pumps the position of the discharge valve at start up is not critical and the general practice is to start the pump with the valve in a partially open position. Special consideration must be given to the following conditions:

If the pump is to discharge into a system that is already pressurized, ensure that the system pressure will not cause reverse flow through the pump during start-up. This can be accomplished by installing a check valve between the pump and the system, or by starting the pump with the discharge valve shut and then opening the valve after all of the air is exhausted and the pump is developing a discharge pressure equal to or greater than the system pressure.

A pump is designed to run at specific head and flow conditions. Operating at conditions other than design can damage the pump.

Operating at low head and high flow conditions can cause the impellers on some pumps to “float”. This can occur if a pump which is designed to operate at system pressure is used to fill the system without throttling the discharge valve to create head (back pressure) on the pump.

Operating some pumps at high head and low flow conditions will cause the pump shaft to stretch sufficiently to allow the impellers to drag on the bowl.

The water hammer created when starting a shallow setting high pressure pump can damage the pump. Special consideration must be given to the rate of releasing the air from these pumps and to the operation of the discharge valve.

If the pump is discharging into a pressurized system it may be necessary to install an automatically operated discharge valve that opens at approximately the same time that the pump develops a discharge head equal to that of the system.

On open line shaft units equipped with pre-lube systems sup-

plied from a pressurized header, open the supply valve and allow the pre-lube water to flow for 15 seconds plus 15 seconds per 100’ of pump setting. The pre-lube system should be left running until after the pump has been started (unless the discharge pressure of the pump will damage the pre-lube system).

On open line shaft units equipped with a tank type pre lube system, clean the tank and fill it with clean water. Open the valve between the pre-lube tank and the pump and allow approximately half of the water in the tank to run into the well. The pump should be started immediately and the pre-lube valve should remain open during the start up.

Upon completion of the above preparations, energize the starter. If any abnormal noises, jerking or vibration is noted, stop the pump immediately, determine the cause of the abnormalities and correct them.

After the pump has come up to speed, and all of the air has been exhausted, regulate the discharge valve to achieve the desired discharge pressure.

If the air release valve is manually operated, close it.

On oil lubricated units adjust the lubricator valve for the flow given in Table 3.

SHAFT SIZE	“A” BASIC SETTING IN DROPS/MINUTE	“B” ADDITIONAL DROPS/MINUTE PER EACH 100 FEET SETTING
7/8 – 1-3/16	5	2
1-1/2 – 1-11/16	7	3
1-15/16 – 2-7/16	10	4

TABLE 3

$$\text{Total Drops/Min.} = \text{“A”} + (\text{Setting} \times \text{“8”}) / 100$$

Example: 500 Feet of 11/16” x 2-1/2”

$$\text{Total Drops/Min.} = 7 + (500 \times 3) / 100 = 22$$

On open line shaft pumps equipped with a stuffing box, adjust the stuffing box packing gland to allow a liberal amount of leakage past the packing. A small trickle is desirable. On units where the pressure at the stuffing box is very low, it may be necessary to plug the “R” port on the stuffing box as shown in Figure XX in order to obtain leakage through the top rings of packing. On high pressure units where leakage through the

gland is excessive, it may be necessary to move the grease cup to the “R” port and install a throttle valve in the “G” port. The pressure on the gland can then be regulated using the throttle valve. Do not reverse the ports if a reverse ported stuffing box was supplied by the factory. During the first four or five hours of operation, periodically observe the leakage and feel of the gland. If necessary, loosen the gland to restore the leakage to the desired rate or to prevent the gland from overheating. The water leaking past the packing should not be allowed to become hot enough to steam. If the packing is allowed to overheat, it will score the shaft, requiring replacement of the packing and the shaft. After five or six hours of operation gradually tighten the gland (do not tighten the gland follower nuts more than 1/6 turn in ten minutes) to reduce the leakage. **DO NOT COMPLETELY STOP THE LEAKAGE PAST THE PACKING and DO NOT ALLOW THE GLAND TO OVERHEAT.** Check periodically to see that the gland is not leaking excessively and that it is not overheating.

If the unit is equipped with a pre-lube water tank and a manual valve, close the valve to the tank after the tank has filled with water.

Assure that the driver and auxiliary equipment is operating satisfactorily by performing the checks recommended by the manufacturer.

Check all fittings and joints for leakage

Check the pumping level of the well to assure that the pump bowl remains submerged when it is operating.

If no trouble is encountered the pump should be allowed to run until the water from the well is clear and free of all solids. Short ON-OFF cycles at initial startup or at startup on a pump which has been idle for an extended period can cause “sand-locking” of the pump if the pump is not allowed to run long enough to obtain clear water.

On open line shaft pumps requiring post-lube, assure that post-lube is provided when the pump is stopped. (Post lube is required on open line shaft pumps which operate at a static water level of greater than 100 ft. and which are not equipped with a non-reverse mechanism.)

After the pump is shut down for the first time, repeat the impeller adjustment procedure given in VERTICAL HOLLOW SHAFT or VERTICAL SOLID SHAFT adjustments on pages 23 or 24. This is necessary because some of the shaft joints may have tightened during initial start up, thus changing the initial adjustment.

## NORMAL OPERATION AND MAINTENANCE

Subsequent normal start ups are essentially the same as the initial start up described above, consisting of:

- Checking that the driver, the auxiliary equipment and the system into which the pump is discharging are ready for operation.
- Pre-lubing the pump as recommended.
- Pressing the “Start” button.
- Checking or adjusting system for desired flow.
- Check for proper oil drip rate or stuffing box leakage whichever is applicable.
- Initiate post-lube (if required) when the pump is shut down.

On oil lubricated units, periodically check the oil level in the lubricator tank. Refill the tank if it is less than 1/4 full.

On water lubricated units, periodically check the packing for overheating or excess flow. The amount of adjusting done on the packing gland should be held to a minimum.

Apply grease to the stuffing box at the rate of one pump of the grease gun for each 24 hours of operation. Usually up to two additional rings of packing can be installed in the stuffing box to compensate for wear and compression of the packing. However, if difficulty is encountered in adjusting the packing gland after the packing ring has been added, then all of the packing should be removed and the stuffing box completely repacked.

To repack the stuffing box, remove all the old packing, separator rings and lantern ring. The packing can be removed using packing hooks which are designed for this purpose. The separator rings and lantern ring can be removed by forming a small hook at the end of a piece of small stiff wire and inserting this hook into the holes provided in the lantern ring and separator rings. A mirror will be useful for looking into the stuffing box cavity since the amount of working space is minimal. Also, some soft wire or string can be used to tie the separator rings and lantern rings up out of the way. Clean the stuffing box cavity, inspect the shaft for scoring and install the new packing using the instructions given on the “Stuffing Box Assembly” sheet originally supplied with the pump. Adjust the packing gland per the instructions given above on page 29.

# TROUBLESHOOTING

When properly installed and operating in non-abrasive, non-corrosive water a pump is a relatively long lived piece of machinery, requiring a minimum of attention. However, machinery is subject to wear. The most common causes of improper operation are given below.

These include problems created by wear and other adverse conditions. Note that most of these problems require removal of the pump from the well in order to correct the problem. Contact the factory or your representative for this type of service.

PROBLEM	POSSIBLE CAUSE	RECOMMENDED REMEDY
Problem #1 Pump not reaching design flow rate.	1.1 Insufficient NPSHA. (Noise may not be present)	Recalculate NPSH available. It must be greater than the NPSH required by pump at desired flow. If not, redesign suction piping, holding number of elbows and number of planes to a minimum to avoid adverse flow rotation as it approaches the impeller.
	1.2 System head greater than anticipated.	Reduce system head by increasing pipe size and/ than or reducing number of fittings. Increase impeller diameter. NOTE: Increasing impeller diameter may require use of a larger motor.
	1.3 Entrained air.	Air leak from atmosphere on suction side. 1. Check suction line gaskets and threads for tightness. 2. If vortex formation is observed in suction tank, install vortex breaker. 3. Check for minimum submergence.
	1.4 Entrained gas from process.	Process generated gases may require larger pumps.
	1.5 Speed too low.	Check motor speed against design speed.
	1.6 Direction of rotation wrong.	After confirming wrong rotation, reverse any two of three leads on a three phase motor. The pump should be disassembled and inspected before it is restarted.
	1.7 Impeller too small.	Replace with proper diameter impeller. NOTE: Increasing impeller diameter may require use of a larger motor.
	1.8 Impeller clearance too large.	Replace impeller and/or case wear rings.
	1.9 Plugged impeller, suction line or casing which may be due to a product or large solids.	1. Reduce length of fiber when possible. 2. Reduce solids in the process fluid when possible. 3. Consider larger pump.
	1.10 Wet end parts (casing cover, impeller) worn, corroded or missing.	Replace part or parts.
Problem #2.0 Pump not reaching design head (TDH).	2.1 Refer to possible causes under Problem #1.0.	Refer to remedies listed under Problem #1.0 and #3.0.
Problem #3.0 No discharge or flow	3.1 Not properly primed.	Repeat priming operation, recheck instructions. If pump has run dry, disassemble and inspect the pump before operation.

PROBLEM	POSSIBLE CAUSE	RECOMMENDED REMEDY
Cont. Problem #3.0 No discharge or flow	3.2 Direction of rotation wrong.	After confirming wrong rotation, reverse any two of three leads on a three phase motor. The pump should be disassembled and inspected before operation.
	3.3 Entrained air.	Air leak from atmosphere on suction side. Refer to recommended remedy under Problem #1.0, Item #1.3.
	3.4 Plugged impeller, suction line or casing which may be due to a fibrous product or large solids.	Refer to recommended remedy under Problem #1.0, Item #1.9.
	3.5 Damaged pump shaft, impeller.	Replace damaged parts.
Problem #4.0 Pump operates for short period, then loses prime.	4.1 Insufficient NPSH.	Refer to recommended remedy under Problem #1.0, Item #1.1.
	4.2 Entrained air.	Air leak from atmosphere on suction side. Refer to recommended remedy under Problem #1.0, Item #1.1.
Problem #5.0 Excessive noise from wet end.	5.1 Cavitation - insufficient NPSH available.	Refer to recommended remedy under Problem #1.0, Item #1.1.
	5.2 Abnormal fluid rotation due to complex suction piping.	Redesign suction piping, holder number of elbows and number of planes to a minimum to avoid adverse fluid rotation as it approaches the impeller.
	5.3 Impeller rubbing.	1. Replace impeller and/or case wear rings. 2. Check outboard bearing assembly for axial end play.
Problem #6.0 Excessive noise from bearings.	6.1 Bearing contamination appearing on the raceways as scoring, pitting, scratching, or rusting caused by adverse environment and entrance of abrasive contaminants from atmosphere.	1. Work with clean tools in clean surroundings. 2. Remove all outside dirt from housing before exposing bearings. 3. Handle with clean dry hands. 4. Treat a used bearing as carefully as a new one. 5. Use clean solvent and flushing oil. 6. Protect disassembled bearing from dirt and moisture. 7. Keep bearings wrapped in paper or clean cloth while not in use. 8. Clean inside of housing before replacing bearings. 9. Check oil seals and replace as required. 10. Check all plugs and tapped openings to make sure that they are tight.

PROBLEM	POSSIBLE CAUSE	RECOMMENDED REMEDY
<p>Cont. Problem #6.0 Excessive noise from bearings.</p>	<p>6.2 Brinelling of bearing identified by indentation on the ball races, usually caused by incorrectly applied forces in assembling the bearing or by shock loading such as hitting the bearing or drive shaft with a hammer.</p>	<p>When mounting the bearing on the outboard end use a proper size ring and apply the pressure against the inner ring only. Be sure when mounting a bearing to apply the mounting pressure slowly and evenly.</p>
	<p>6.3 False brinelling of bearing identified again by either axial or circumferential indentations usually caused by vibration of the balls between the races in a stationary bearing.</p>	<ol style="list-style-type: none"> <li>1. Correct the source of vibration.</li> <li>2. Where bearings are oil lubricated and employed in units that may be out of service for extended periods, the drive shaft should be turned over periodically to re-lubricate all bearing surfaces at intervals of one-to three months.</li> </ol>
	<p>6.4 Thrust overload on bearing identified by flaking ball path on one side of the outer race or in the case of maximum capacity bearings, may appear as a spalling of the races in the vicinity of the loading slot. (Please note: maximum capacity bearings are not recommended in HD pumps.) These thrust failures are caused by improper mounting of the bearing or excessive thrust loads.</p>	<ol style="list-style-type: none"> <li>1. Follow correct mounting procedures for bearings.</li> </ol>
	<p>6.5 Misalignment identified by fracture of ball retainer or a wide ball path on the inner race and a narrower cocked ball path on the outer race. Misalignment is caused by poor mounting practices or defective drive shaft. For example bearing not square with the centerline or possibly a bent shaft due to improper handling.</p>	<p>Handle parts carefully and follow recommended mounting procedures. Check all parts for proper fit and alignment.</p>
	<p>6.6 Bearing damaged by electric arcing identified as electro-etching of both inner and outer ring as a pitting or cratering. Electrical arcing is caused by a static electrical charge emanating from belt drives, electrical leakage or short circuiting.</p>	<ol style="list-style-type: none"> <li>1. Where current shunting through the bearing cannot be corrected, a shunt in the form of a slip ring assembly should be incorporated.</li> <li>2. Check all wiring, insulation and rotor windings to be sure that they are sound and all connections are properly made.</li> <li>3. Where pumps are belt driven, consider the elimination of static charges by proper grounding or consider belt material that is less generative.</li> </ol>



PROBLEM	POSSIBLE CAUSE	RECOMMENDED REMEDY
<p>Cont. Problem #6.0 Excessive noise from bearings.</p>	<p>6.7 Bearing damage due to improper lubrication, identified by one or more of the following:</p> <ol style="list-style-type: none"> <li>1. Abnormal bearing temperature rise.</li> <li>2. A stiff cracked grease appearance.</li> <li>3. A brown or bluish discoloration of the bearing races.</li> </ol>	<ol style="list-style-type: none"> <li>1. Be sure the lubricant is clean.</li> <li>2. Be sure proper amount of lubricant is used. The constant level oiler supplied with HD pumps will maintain the proper oil level if it is installed and operating properly. In the case of greased lubricated bearings, be sure that there is space adjacent to the bearing into which it can rid itself of excessive lubricant, otherwise the bearing may overheat and fail prematurely.</li> <li>3. Be sure the proper grade of lubricant is used.</li> </ol>

## SPARE PARTS

### RECOMMENDED SPARE PARTS

The decision about what spare parts you may wish to stock varies greatly depending upon many factors. Major factors in this decision process are criticality of the application, delivery timing for needed spares, the erosive/corrosive nature of the application, cost of potential spares and inventory/handling costs. For assistance with identifying recommended spare parts please contact the American-Marsh Aftermarket team, or send an email to [amp.parts@wilo.com](mailto:amp.parts@wilo.com).

### HOW TO ORDER SPARE PARTS

Spare parts can be ordered from your local American-Marsh Authorized Distributor or Service Center. The unit model and serial number information can be found on the factory Serial Tag, and will be needed to ensure the correct replacement parts are identified. You may contact [amp.parts@wilo.com](mailto:amp.parts@wilo.com) for additional support and technical questions.

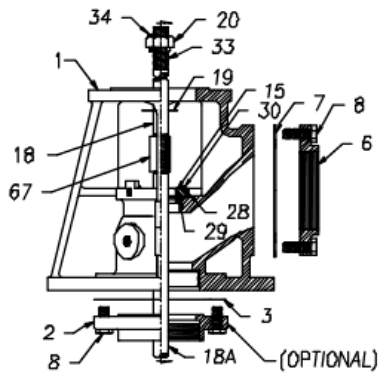

TYPICAL STANDARD HEAD

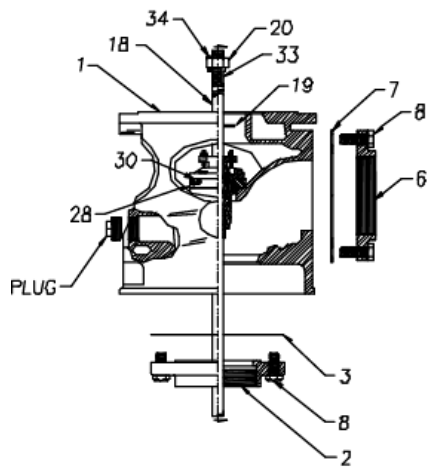

TYPICAL HEAVY DUTY HEAD

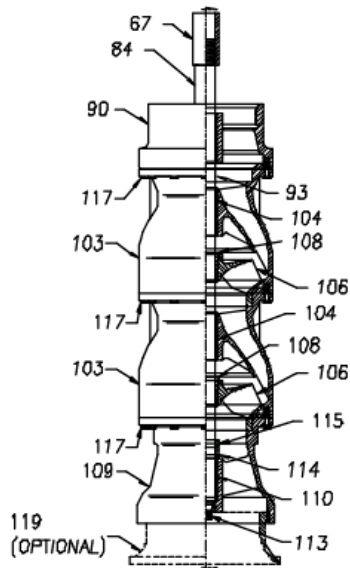

BOWL ASSEMBLY

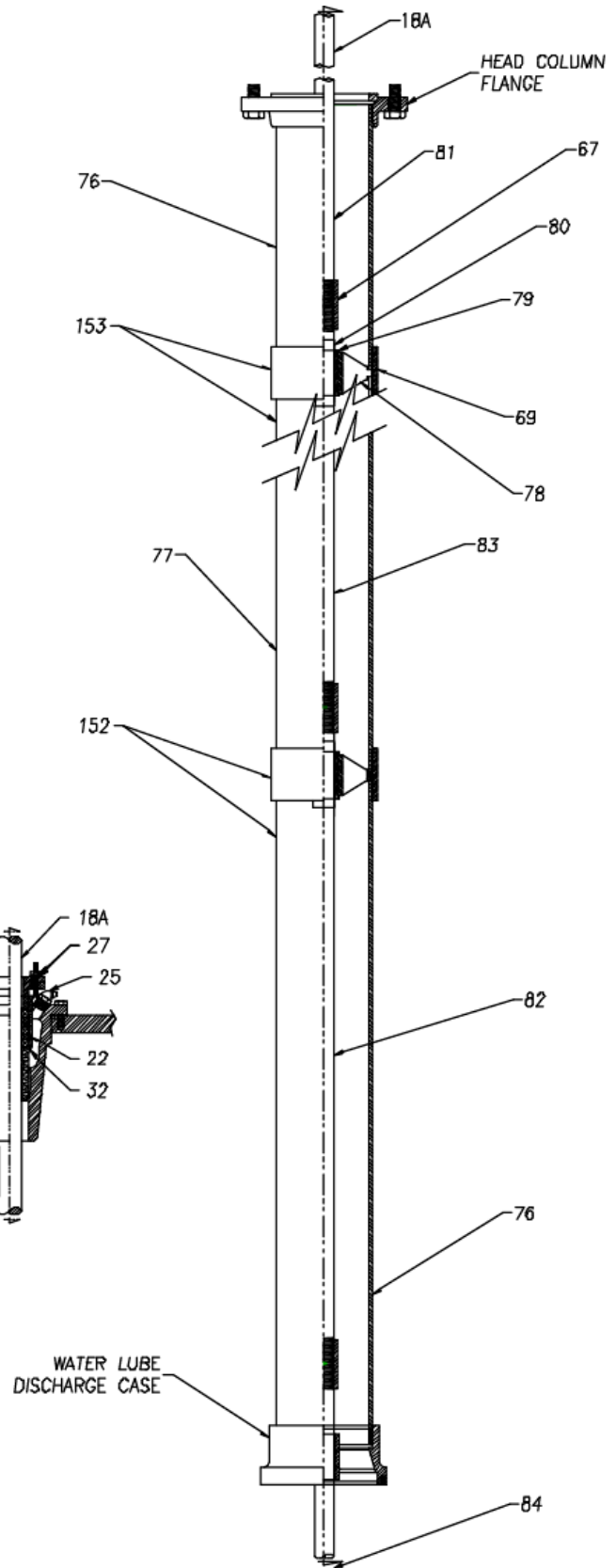
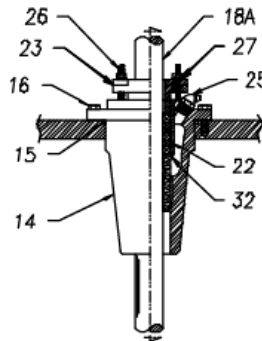

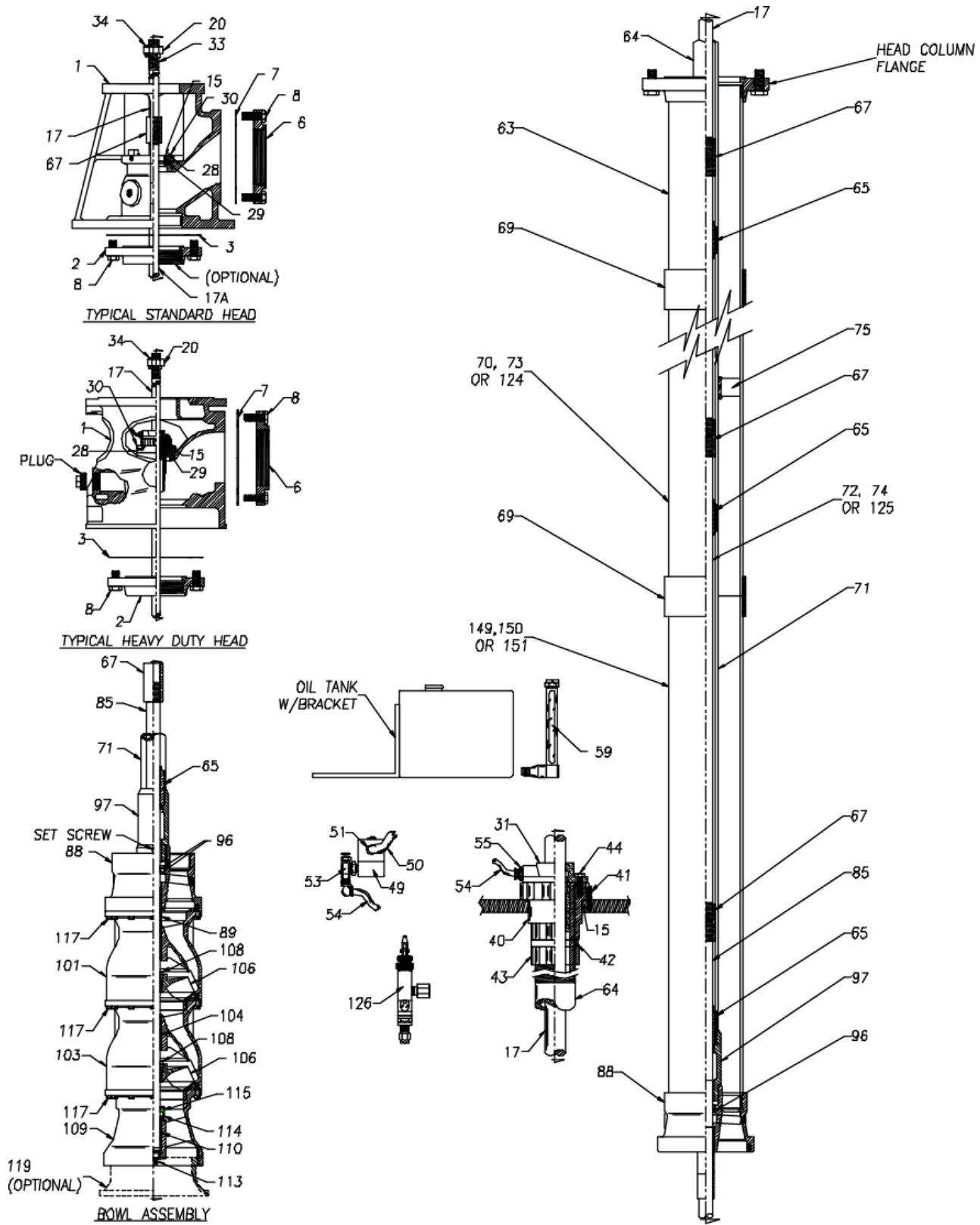

## VERTICAL TURBINE SECTIONALS

Item Number	Item Description	Item Number	Item Description
1	Discharge Head	70	Oil Lubricated O/C Section (10' 0" long) TBE
2	Head Column Flange	71	I/C Section (5' 0" long)
3	Head Column Flange Gasket	72	Oil Lubricated L/S Section (10' 0" long)
4	Studs	73	Oil Lubricated O/C Section (5' 0" long) TBE
5	Nuts	74	Oil Lubricated L/S Section (5' 0" long) TBE
6	Head Discharge Flange	75	I/C Stabilizing Spider
7	Head Discharge Flange Gasket	76	Water Lubricated O/C Section
8	Discharge Flange Assembly Cap Screws	77	Water Lubricated O/C Section
9	Discharge Flange Assembly Nuts	78	Water Lubricated L/S Bearing Spider
10	Head Discharge Flange Assembly Studs	79	Water Lubricated L/S Bearing
11	Head Discharge Flange Assembly Nuts	80	Water Lubricated L/S Sleeve
14	Head Packing Housing with Bearing	81	Water Lubricated L/S Extension (3' 9-7/8" long)
15	O-Ring	82	Water Lubricated L/S Section (5' 0" long)
16	Head Packing Housing Cap Screws	83	Water Lubricated L/S Section (10' 0" long)
17	Oil Lubricated Headshaft	84	Water Lubricated Bowl Shaft
18	Water Lubricated Headshaft	85	Oil Lubricated Bowl Shaft
18A	Top Shaft	88	Oil Lubricated Discharge Case
19	Headshaft Flinger	89	Oil Lubricated Discharge Case Bearing
20	Headshaft Adjusting Nut	90	Water Lubricated Case Bearing
22	Packing (Set)	91	Water Lubricated Case Bearing
23	Packing Follower	93	Water Lubricated Case Bearing
25	Head Packing Housing Grease Fittings	94	Sand Cap Set Screws
26	Packing Follower Studs	96	Shaft Seal
27	Packing Follower Retainer Nuts	97	I/C Adapter Coupling
28	Adapter Flange	101	Top Bowl Assembly
29	Adapter Flange O-Ring	102	Top Bowl Bearing
30	Adapter Flange Assembly Cap Screws	103	Bowl Assembly (Enclosed Type)
31	Oil Lubricated Headshaft Bearing	104	Bowl Bearing
32	Water Lubricated Headshaft Bearing	105	Bowl Assembly (Semi-Open Type)
33	Water Lubricated Headshaft Bearing	106	Impeller (Enclosed Type)
34	Adjusting Nut Machine Screw	107	Impeller (Semi-Open Type)
40	I/C Tension Nut	108	Taper Lock
41	Tension Nut Set Screw	109	Suction Case Assembly (Enclosed Type)
42	I/C Seal Ring	110	Suction Case Bearing
43	I/C Seal Ring Nut	111	Suction Case Assembly
44	Headshaft Bearing Assembly Cap Screws	113	Suction Case End Plug
45	Headshaft Bearing Dust Seal	114	Suction Case Sand Cap
49	Solenoids Valve	115	Optional Set Screws for Brass Sand Cap
53	Vented Sight Drip Valve	116	Bowl Suction Flange
54	Tubing for Oil Lubrication	117	Bowl Assembly Cap Screws
55	Oil Line Connector for Headshaft Bearing	119	Suction Bell (Optional)
59	Oil Level Sight Glass	124	Oil Lubricated O/C Section (20' 0" long)
63	2' Long O/C Adapter Nipple TBE Top Section	125	Oil Lubricated L/S Section (20' 0" long)
64	Inner Column Adapter 2' 4" Long Stretch Nipple	126	Vented Toggle Valve
65	Oil Lubricated Lineshaft Bearing	149	Oil Lubricated O/C Assembly T&C (10' 0" long)
66	Oil Lubricated Lineshaft Adapter Bearing	150	Oil Lubricated O/C Assembly T&C (5' 0" long)
67	Shaft Coupling	151	Oil Lubricated O/C Assembly T&C (20' 0" long)
68	Shaft Adapter Coupling	152	Water Lubricated O/C Assembly T&C (10' 0" long)
69	O/C Coupling	153	Water Lubricated O/C Assembly T&C (5' 0" long)