

340 Series HD Double Suction Split Case Pumps

Installation and Operating Manual

Contents

4	Safety considerations
5	Pump identification
5	Manufacturer
5	Type of pump
5	Date of manufacture
5	Installation, operation & maintenance manual identification
5	Warranty
5	General instructions
6	Handling and transport
6	Method of transport
6	Storage
7	Installation & alignment
7	Factory preliminary alignment procedure
7	Recommended procedure for base plate installation & final field alignment
9	Piping connection – suction & discharge
10	Suction piping
11	Discharge piping
12	Pump and shaft alignment check
12	Mechanical seal
12	Packing
12	Piping connection –seal/packing support system
12	Bearing lubrication
13	Coupling
13	Pump operation
13	Rotation check
14	Pre-start-up checks
14	Priming
14	Ensuring proper npsha
14	Minimum flow
15	Starting the pump and adjusting flow
15	Operation in sub-freezing conditions
15	Shutdown considerations
16	Troubleshooting
21	Maintenance
21	Preventive maintenance
21	Need for maintenance records
21	Need for cleanliness
21	Maintenance of pump due to flood damage
21	Disassembly
23	Re-assembly
29	Appendix A

SAFETY CONSIDERATIONS

The American-Marsh 340 Series Horizontal Splitcase pumps have been designed and manufactured for safe operation. In order to ensure safe operation, it is very important that this manual be read in its entirety prior to installing or operating the system. American-Marsh Pumps shall not be liable for physical injury, damage or delays caused by a failure to observe the instructions for installation, operation and maintenance contained in this manual.

Remember that every pump has the potential to be dangerous, because of the following factors:

- Parts are rotating at high speeds
- High pressures may be present
- High temperatures may be present
- Highly corrosive and/or toxic chemicals may be present

Paying constant attention to safety is always extremely important. However, there are often situations that require special attention. These situations are indicated throughout this book by the following symbols:



DANGER - Immediate hazards which **WILL** result in severe personal injury or death.



WARNING – Hazards or unsafe practices which **COULD** result in severe personal injury or death.



CAUTION – Hazards or unsafe practices which **COULD** result in minor personal injury or product or property damage.

Maximum Lifting Speed: 15 feet/second.

If in a climate where the fluid in the system could freeze, never

leave liquid in the booster system. Drain the system completely. During winter months and cold weather, the liquid could freeze and damage the system components.

Do not run the equipment dry or start the pump without the proper prime (flooded system).

Never operate the pump(s) for more than a short interval with the discharge valve closed. The length of the interval depends on several factors including the nature of the fluid pumped and its temperature. Contact American-Marsh Engineering for additional support if required.

Never operate the system with a closed suction valve.

Excessive pump noise or vibration may indicate a dangerous operating condition. The pump(s) must be shutdown immediately.

Do not operate the pump and/or the system for an extended period of time below the recommended minimum flow.

It is absolutely essential that the rotation of the motor be checked before starting any pump in the system. Incorrect rotation of the pump(s) for even a short period of time can cause severe damage to the pumping assembly.

If the liquid is hazardous, take all necessary precautions to avoid damage and injury before emptying the pump casing.

Residual liquid may be found in the pump casing, suction and discharge manifolds. Take the necessary precautions if the liquid is hazardous, flammable, corrosive, poisonous, infected, etc.

Always lockout power to the driver before performing pump maintenance.

Never operate the pump without the coupling guard (if supplied) and all other safety devices correctly installed.

Do not apply heat to disassemble the pump or to remove the impeller. Entrapped liquid could cause an explosion.

If any external leaks are found while pumping hazardous product, immediately stop operations and repair.

PUMP IDENTIFICATION

MANUFACTURER

American-Marsh Pumps
550 E. South St.
Collierville, TN 38017

United States of America

TYPE OF PUMP

The American-Marsh HD split case pump is a horizontal, double suction, single stage, axially split centrifugal pump.

DATE OF MANUFACTURE

The date of manufacture is indicated on the pump data plate.

INSTALLATION, OPERATION & MAINTENANCE MANUAL IDENTIFICATION

Prepared: October 1, 2021 Edition: 01
Revision: Date of Revision:

NAMEPLATE INFORMATION

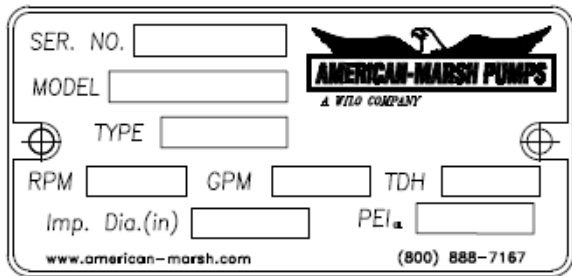

FIGURE 1 – Pump Data Plate

SERIAL NUMBER

: Serial Number of pump unit (issued by Production Control)

SIZE

: Size designation of pump (4x6-10)

TYPE

: Pump type (HD)

RPM

: Speed of pump

GPM

: Rated capacity of pump

TDH

: Rated Total Dynamic Head of pump

WARRANTY

American-Marsh Pumps guarantees that only high quality materials are used in the construction of our pumps and that machining and assembly are carried out to high standards.

The pumps are guaranteed against defective materials and/or faulty craftsmanship for a period of one year from the date of shipment unless specifically stated otherwise.

Replacement of parts or of the pump itself can only be carried out after careful examination of the pump by qualified personnel.

The warranty is not valid if third parties have tampered with the pump.

This warranty does not cover parts subject to deterioration or wear and tear (mechanical seals, pressure and vacuum gauges, rubber or plastic items, bearings, etc.) or damage caused by misuse or improper handling of the pump by the end user.

Parts replaced under warranty become the property of American-Marsh Pumps.

Contact the American-Marsh Pumps' factory:

American-Marsh Pumps
550 E. South St.
Collierville, TN 38017
United States Of America

Phone: (901) 860-2300

Fax: (901) 860-2323

www.american-marsh.com

GENERAL INSTRUCTIONS

The pump and motor unit must be examined upon arrival to ascertain any damage caused during shipment. If damaged immediately notify the carrier and/or the sender. Check that the goods correspond exactly to the description on the shipping documents and report any differences as soon as possible to the sender. Always quote the pump type and serial number stamped on the data plate.

The pumps must be used only for applications for which the manufacturers have specified:

- The construction materials
- The operating conditions (flow, pressure, temperature, etc.)
- The field of application

In case of doubt, contact the manufacturer.

HANDLING AND TRANSPORT

METHOD OF TRANSPORT

The pump must be transported in the horizontal position

INSTALLATION

During installation and maintenance, all components must be handled and transported securely by using suitable slings. Handling must be carried out by specialized personnel to avoid damage to the pump and persons. The lifting rings attached to various components should be used exclusively to lift the components for which they have been supplied.



Maximum lifting speed: 15 feet/second

It is important to exercise extreme care in handling and installing all parts. Certain items are precision machined for proper alignment and, if dropped, banged, sprung, or mistreated in any way, misalignment and malfunction will result. Other components, such as the electrical cable, may be vulnerable to gouging or scuffing. Parts which are too heavy to be lifted from the transporting car or truck should be skidded slowly and carefully to the ground to prevent damage. Never unload by dropping parts directly from the carrier to the ground and never use shipping crates for skids.

If job site conditions permit, you may be able to install directly from the truck that delivered the pump. If not, move the components to the installation area and lay them out in a clean and protected space convenient to the work location. Column pipe sections should be placed on suitable timbers to keep them out of the dirt, arranged so that the coupling ends point toward the wellhead. The bowl/motor assembly should be left on the skids until lifted for installation. The power cable and motor leads must receive special protection to avoid damage to jacket or insulation.

If installation cannot begin within a few days after delivery, segregate and identify all components of the shipment so they won't be confused with other equipment arriving at the job site.

Read and follow the storage instructions carefully because care of the pump during this period before installation can be as important as maintenance after operation has begun.

Check all parts against the packing list to make sure nothing is missing. It is much better to find out now than during the

installation.

STORAGE

SHORT-TERM STORAGE

Normal packaging is designed to protect the pump during shipment and for dry, indoor storage for up to two months or less. The procedure followed for this short-term storage is summarized below:

Standard Protection for Shipment :

a. Loose unmounted items, including, but not limited to, oilers, packing, coupling spacers, stilts, and mechanical seals are packaged in a water proof plastic bag and placed under the coupling guard. Larger items are cartoned and metal banded to the base plate. For pumps not mounted on a base plate, the bag and/or carton is placed inside the shipping carton. All parts bags and cartons are identified with the American-Marsh sales order number, the customer purchase order number, and the pump item number (if applicable).

b. Inner surfaces of the bearing housing, shaft (area through bearing housing), and bearings are coated with Cortec VCI-329 rust inhibitor, or equal.

Note: Bearing housings are not filled with oil prior to shipment.

c. Regreasable bearings are packed with grease (Royal Purple NLGI#2).

d. After a performance test, if required, the pump is tipped on the suction flange for drainage (some residual water may remain in the casing). Then, internal surfaces of ferrous casings, covers, flange faces, and the impeller surface are sprayed with Calgon Vestal Labs RP-743m, or equal. Exposed shafts are taped with Polywrap.

e. Flange faces are protected with plastic covers secured with plastic drive bolts. 3/16 in (7.8 mm) steel or 1/4 in (6.3 mm) wood covers with rubber gaskets, steel bolts, and nuts are available at extra cost.

f. All assemblies are bolted to a wood skid which confines the assembly within the perimeter of the skid.

g. Assemblies with special paint are protected with a plastic wrap.

h. Bare pumps, when not mounted on base plates, are bolted to wood skids.

i. All assemblies having external piping (seal flush and cooling water plans), etc. are packaged and braced to withstand normal handling during shipment. In some cases components may be disassembled for shipment. The pump must be stored in a covered, dry location.

LONG-TERM STORAGE

Long-term storage is defined as more than two months, but less than 12 months. The procedure American-Marsh follows for long-term storage of pumps is given below. These procedures are in addition to the short-term procedure.

Solid wood skids are utilized. Holes are drilled in the skid to accommodate the anchor bolt holes in the base plate, or the casing and bearing housing feet holes on assemblies less base plate. Tackwrap sheeting is then placed on top of the skid and the pump assembly is placed on top of the Tackwrap. Metal bolts with washers and rubber bushings are inserted through the skid, the Tackwrap, and the assembly from the bottom of the skid and are then secured with hex nuts. When the nuts are “snugged” down to the top of the base plate or casing and bearing housing feet, the rubber bushing is expanded, sealing the hole from the atmosphere. Desiccant bags are placed on the Tackwrap. The Tackwrap is drawn up around the assembly and hermetically (heat) sealed across the top. The assembly is completely sealed from the atmosphere and the desiccant will absorb any entrapped moisture. A solid wood box is then used to cover the assembly to provide protection from the elements and handling. This packaging will provide protection up to twelve months without damage to mechanical seals, bearings, lip seals, etc. due to humidity, salt laden air, dust, etc. After unpacking, protection will be the responsibility of the user. Addition of oil to the bearing housing will remove the inhibitor. If units are to be idle for extended periods after addition of lubricants, inhibitor oils and greases should be used.

Every three months, the shaft should be rotated approximately 10 revolutions.

INSTALLATION & ALIGNMENT

FACTORY PRELIMINARY ALIGNMENT PROCEDURE

The purpose of factory alignment is to ensure that the user will have full utilization of the clearance in the motor holes for final job-site alignment. To achieve this, the factory alignment procedure specifies that the pump be aligned in the horizontal plane to the motor, with the motor foot bolts centered in the motor holes. This procedure ensures that there is sufficient clearance in the motor holes for the customer to field align the motor to the pump, to zero tolerance. This philosophy requires that the customer be able to place the base in the same condition as the factory. Thus the factory alignment will be done with

the base sitting in an unrestrained condition on a flat and level surface. This standard also emphasizes the need to ensure the shaft spacing is adequate to accept the specified coupling spacer. The factory alignment procedure is summarized below:

1. The base plate is placed on a flat and level work bench in a free and unstressed position.
2. The base plate is leveled as necessary. Leveling is accomplished by placing shims under the rails (or, feet) of the base at the appropriate anchor bolt hole locations. Levelness is checked in both the longitudinal and lateral directions.
3. The motor and appropriate motor mounting hardware is placed on the base plate and the motor is checked for any planar soft-foot condition. If any is present it is eliminated by shimming.
4. The motor feet holes are centered around the motor mounting fasteners.
5. The motor is fastened in place by tightening the nuts on two diagonal motor mounting studs.
6. The pump is put onto the base plate and leveled. If an adjustment is necessary, we add or delete shims between the pump foot and the base plate.
7. The spacer coupling gap is verified.
8. The parallel and angular vertical alignment is made by shimming under the motor.
9. All four motor feet are tightened down.
10. The pump and motor shafts are then aligned *horizontally*, both parallel and angular, by *moving the pump* to the fixed motor. The pump feet are tightened down.
11. Both horizontal and vertical alignment are again final checked as is the coupling spacer gap.

RECOMMENDED PROCEDURE FOR BASE PLATE INSTALLATION & FINAL FIELD ALIGNMENT

NEW GROUTED BASE PLATES

1. The pump foundation should be located as close to the source of the fluid to be pumped as practical. There should be adequate space for workers to install, operate, and maintain the pump. The foundation should be sufficient to absorb any vibration and should provide a rigid support for the pump and motor. Recommended

mass of a concrete foundation should be three times that of the pump, motor and base. Note that foundation bolts are imbedded in the concrete inside a sleeve to allow some movement of the bolt.

2. Level the pump base plate assembly. If the base plate has machined coplanar mounting surfaces, these machined surfaces are to be referenced when leveling the base plate. This may require that the pump and motor be removed from the base plate in order to reference the machined faces. If the base plate is without machined coplanar mounting surfaces, the pump and motor are to be left on the base plate. The proper surfaces to reference when leveling the pump base plate assembly are the pump suction and discharge flanges. DO NOT stress the base plate. Do not bolt the suction or discharge flanges of the pump to the piping until the base plate foundation is completely installed. If equipped, use leveling jackscrews to level the base plate. If jackscrews are not provided, shims and wedges should be used. See Figure 2. Check for levelness in both the longitudinal and lateral directions. Shims should be placed at all base anchor bolt locations, and in the middle edge of the base if the base is more than five feet long. Do not rely on the bottom of the base plate to be flat. Standard base plate bottoms are not machined, and it is not likely that the field mounting surface is flat.

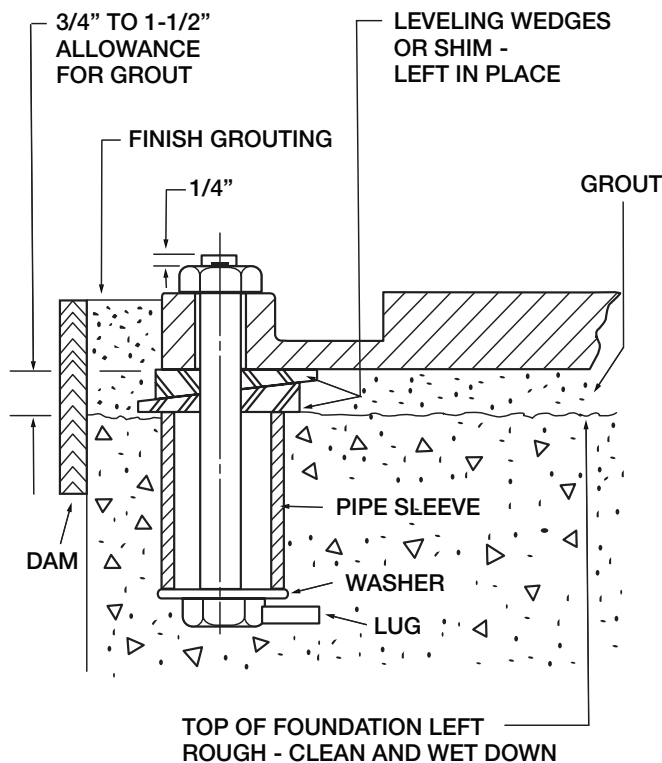

FIGURE 2 – Base Plate Foundation

3. After leveling the base plate, tighten the anchor bolts. If shims were used, make sure that the base plate was shimmed near each anchor bolt before tightening. Failure to do this may result in a twist of the base plate, which could make it impossible to obtain final alignment. Check the level of the base plate to make sure that tightening the anchor bolts did not disturb the level of the base plate. If the anchor bolts did change the level, adjust the jackscrews or shims as needed to level the base plate. Continue adjusting the jackscrews or shims and tightening the anchor bolts until the base plate is level.

4. Check initial alignment. If the pump and motor were removed from the base plate proceed with step 5 first, then the pump and motor should be reinstalled onto the base plate using American-Marsh's Factory Preliminary Alignment Procedure, and then continue with the following. As described above, pumps are given a preliminary alignment at the factory. This preliminary alignment is done in a way that ensures that, if the installer duplicates the factory conditions, there will be sufficient clearance between the motor hold down bolts and motor foot holes to move the motor into final alignment. If the pump and motor were properly reinstalled to the base plate or if they were not removed from the base plate and there has been no transit damage, and also if the above steps were done properly, the pump and driver should be within 0.015 in (0.38 mm) FIM (Full Indicator Movement) parallel, and 0.0025 in/in (0.0025 mm/mm) FIM angular. If this is not the case first check to see if the driver mounting fasteners are centered in the driver feet holes. If not, re-center the fasteners and perform a preliminary alignment to the above tolerances by shimming under the motor for vertical alignment, and by moving the pump for horizontal alignment.

5. *Grout the base plate.* A non-shrinking grout should be used. Grout compensates for uneven foundation, distributes weight of unit, and prevents shifting. Use an approved, non-shrinking grout, after setting and leveling unit.

- a. Build strong form around the foundation to contain grout.
- b. Soak top of concrete foundation thoroughly, then remove surface water.
- c. Under pedestal should be completely filled with grout.
- d. After the grout has thoroughly hardened, check the foundation bolts and tighten if necessary.

e. Approximately 14 days after the grout has been poured or when the grout has thoroughly dried, apply an oil base paint to the exposed edges of the grout to prevent air and moisture from coming in contact with the grout.

Make sure that the grout fills the area under the base plate. After the grout has cured, check for voids and repair them.

6. Run piping to the suction and discharge of the pump. There should be no piping loads transmitted to the pump after connection is made. Recheck the alignment to verify that there are no significant loads.

7. Perform final alignment. Check for soft-foot under the driver. An indicator placed on the coupling, reading in the vertical direction, should not indicate more than 0.002 in (0.05 mm) movement when any driver fastener is loosened. Align the driver first in the vertical direction by shimming underneath its feet. When satisfactory alignment is obtained the number of shims in the pack should be minimized. It is recommended that no more than five shims be used under any foot. Final horizontal alignment is made by moving the driver. Maximum pump reliability is obtained by having near perfect alignment. American-Marsh recommends no more than 0.002 in (0.05mm) parallel, and 0.0005 in/in (0.0005 mm/mm) angular misalignment.

8. Operate the pump for at least an hour or until it reaches final operating temperature. Shut the pump down and recheck alignment while the pump is hot. Piping thermal expansion may change the alignment. Realign pump as necessary.

EXISTING GROUDED BASE PLATES

When a pump is being installed on an existing grouted base plate, the procedure is somewhat different from the previous section “New Grouted Base Plates.”

1. Mount the pump on the existing base plate.
2. Level the pump by putting a level on the discharge flange. If not level, add or delete shims between the pump foot and the base plate.
3. Check initial alignment. (Step 4 above)
4. Run piping to the suction and discharge flanges of the pump. (Step 6 above)
5. Perform final alignment. (Step 7 above)
6. Recheck alignment after pump is hot. (Step 8 above)

All piping must be independently supported, accurately aligned and preferably connected to the pump by a short length of flexible piping. The pump should not have to support the weight of the pipe or compensate for misalignment. It should be possible to install suction and discharge bolts through mating flanges without pulling or prying either of the flanges. All piping must be tight. Pumps may air-bind if air is allowed to leak into the piping. If the pump flange(s) have tapped holes, select flange fasteners with thread engagement at least equal to the fastener diameter but that do not bottom out in the tapped holes before the joint is tight.

PIPING CONNECTION – SUCTION & DISCHARGE

When installing the pump piping, be sure to observe the following precautions:

Piping should always be run to the pump.

Do not move pump to pipe. This could make final alignment impossible.

Both the suction and discharge piping should be supported independently near the pump and properly aligned, so that no strain is transmitted to the pump when the flange bolts are tightened. Use pipe hangers or other supports at necessary intervals to provide support. When expansion joints are used in the piping system, they must be installed beyond the piping supports closest to the pump. Tie bolts should be used with expansion joints to prevent pipe strain. Do not install expansion joints next to the pump or in any way that would cause a strain on the pump resulting from system pressure changes. It is usually advisable to increase the size of both suction and discharge pipes at the pump connections to decrease the loss of head from friction.



Piping Forces: Take care during installation and operation to minimize pipe forces and/or moments on the pump casing.

Install piping as straight as possible, avoiding unnecessary bends. Where necessary, use 45-degree or long sweep 90-degree fitting to decrease friction losses.

Make sure that all piping joints are air-tight.

Where flanged joints are used, assure that inside diameters match properly.

Remove burrs and sharp edges when making up joints.

Do not “spring” piping when making any connections.

Provide for pipe expansion when hot fluids are to be pumped.

SUCTION PIPING

When installing the suction piping, observe the following precautions. See Figure 3.

The sizing and installation of the suction piping is extremely important. It must be selected and installed so that pressure losses are minimized and sufficient liquid will flow into the pump when started and operated. Many NPSH (Net Positive

Suction Head) problems can be attributed directly to improper suction piping systems.

Friction losses caused by undersized suction piping can increase the fluid’s velocity into the pump. As recommended by the Hydraulic Institute Standard ANSI/HI 1.1-1.5-1994, suction pipe velocity should not exceed the velocity in the pump suction nozzle. In some situations pipe velocity may need to be further reduced to satisfy pump NPSH requirements and to control suction line losses. Pipe friction can be reduced by using pipes that are one to two sizes larger than the pump suction nozzle in order to maintain pipe velocities less than 5 feet/second.

Suction piping should be short in length, as direct as possible, and never smaller in diameter than the pump suction opening.

If the suction pipe is short, the pipe diameter can be the same size as the suction opening. If longer suction pipe is required, pipes should be one or two sizes larger than the opening, depending on piping length.

Suction piping for horizontal double suction pumps should not be installed with an elbow close to the suction flange of the pump, except when the suction elbow is in the vertical plane.

A suction pipe of the same size as the suction nozzle, approaching at any angle other than straight up or straight down, must have the elbow located 10 pipe diameters from the suction flange of the pump. Vertical mounted pumps and other space limitations require special piping.

There is always an uneven turbulent flow around an elbow. When it is in a position other than the vertical it causes more liquid to enter one side of the impeller than the other. See Figure 4. This results in high un-equalized thrust loads that will overheat the bearings and cause rapid wear, in addition to affecting hydraulic performance.

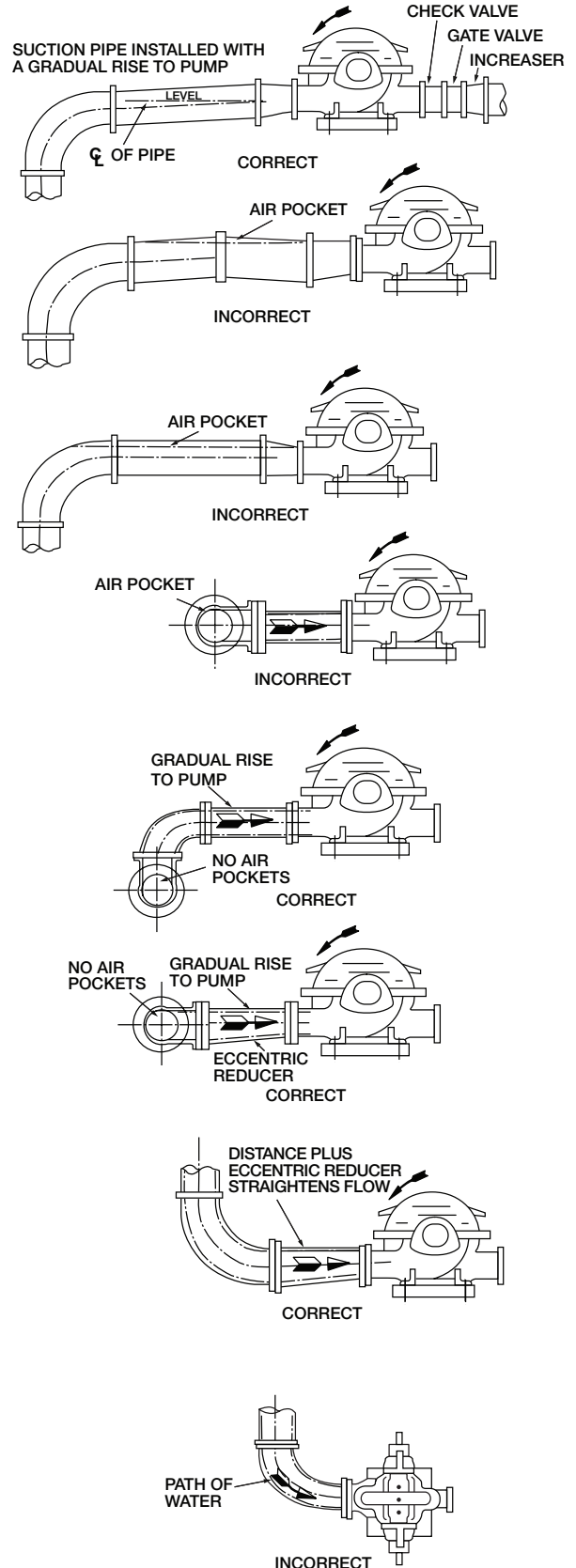

FIGURE 3 – Good Piping Practices

When operating on a suction lift, the suction pipe should slope upward to the pump nozzle. A horizontal suction line must have a gradual rise to the pump. Any high point in the pipe will become filled with air and thus prevent proper operation on the pump. When reducing the piping to the suction opening diameter, use an eccentric reducer with the eccentric side down to avoid air pockets.

NOTE: When operating on suction lift, never use a straight taper reducer in a horizontal suction line, as it tends to form an air pocket in the top of the reducer and the pipe.

To facilitate cleaning pump liquid passage without dismantling pump, a short section of pipe (Dutchman or spool piece), so designed that it can be readily dropped out of the line, can be installed adjacent to the suction flange. With this arrangement, any matter clogging the impeller is accessible by removing the nozzle (or pipe section).

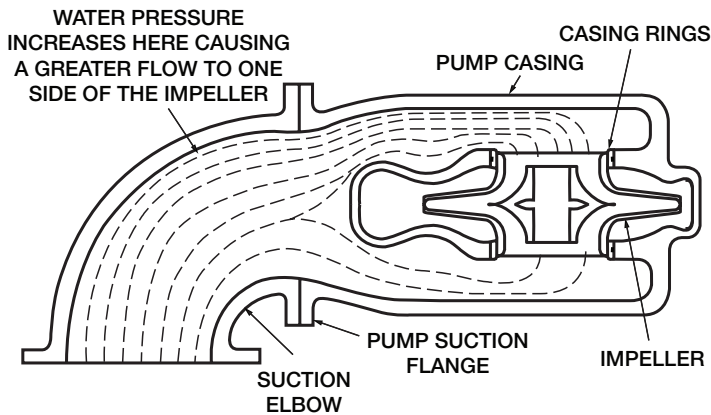

FIGURE 4 – Good Piping Practices

Valves in Suction Piping

When installing valves in the suction piping, observe the following precautions:

- If the pump is operating under static suction lift conditions, a foot valve may be installed in the suction line to avoid the necessity of priming each time the pump is started. This valve should be of the flapper type, rather than the multiple spring type, sized to avoid excessive friction in the suction line. (Under all other conditions, a check valve, if used, should be installed in the discharge line (See “Valves in Discharge Piping” below).
- When foot valves are used, or where there are other possibilities of “water hammer,” close the discharge valve slowly before shutting down the pump.
- Where two or more pumps are connected to the

same suction line, install gate valves so that any pump can be isolated from the line. Gate valves should be installed on the suction side of all pumps with a positive pressure for maintenance purposes. Install gate valves with stems horizontal to avoid air pockets. Globe valves should not be used, particularly where NPSH is critical.

d. The pump must never be throttled by the use of a valve on the suction side of the pump. Suction valves should be used only to isolate the pump for maintenance purposes, and should always be installed in positions to avoid air pockets.

e. A pump drain valve should be installed in the suction piping between the isolation valve and the pump.

DISCHARGE PIPING

If the discharge piping is short, the pipe diameter can be the same as the discharge opening. If the piping is long, pipe diameter should be one or two sizes larger than the discharge opening. On long horizontal runs, it is desirable to maintain as even a grade as possible. Avoid high spots, such as loops, which will collect air and throttle the system or lead to erratic pumping.

Valves in Discharge Piping

A triple duty valve should be installed in the discharge. The triple duty valve placed on the pump protects the pump from excessive back pressure, and prevents liquid from running back through the pump in case of power failure.



When fluid velocity in the pipe is high, for example, 10 ft/s (3 m/s) or higher, a rapidly closing discharge valve can cause a damaging pressure surge. A dampening arrangement should be provided in the piping.

Pressure Gauges

Properly sized pressure gauges should be installed in both the suction and discharge nozzles in the gauge taps (which are provided on request). The gauges will enable the operator to easily observe the operation of the pump, and also determine if the pump is operating in conformance with the performance curve. If cavitation, vapor binding, or other unstable operation should occur, widely fluctuating discharge pressure will be noted.

Pump Insulation

On chilled water applications most pumps are insulated. As part of this practice, the pump bearing housings should not be insulated since this would tend to “trap” heat inside the housing.

This could lead to increased bearing temperatures and premature bearing failures.

PUMP AND SHAFT ALIGNMENT CHECK

After connecting piping, rotate the pump drive shaft clockwise (view from motor end) by hand several complete revolutions to be sure there is no binding and that all parts are free. Recheck shaft alignment. If piping caused unit to be out of alignment, correct piping to relieve strain on the pump.

MECHANICAL SEAL

When the pump is intended to be equipped with a mechanical seal, it is American-Marsh’s standard practice to install the mechanical seal in the pump prior to shipment. Specific order requirements may specify that the seal be shipped separately, or none be supplied. It is the pump installer’s responsibility to determine if a seal was installed. If a seal was supplied but not installed, the seal and installation instructions will be shipped with the pump.



Failure to ensure that a seal is installed may result in serious leakage of the pumped fluid.

Seal and seal support system must be installed and operational as specified by the seal manufacturer.

Mechanical seals are preferred over packing on some applications because of better sealing qualities and longer serviceability.

Leakage is eliminated when a seal is properly installed, and normal life is much greater than that of packing on similar applications.

Pumps containing single mechanical seals normally utilize the pumped liquid to lubricate the seal faces. This method is preferred when the pumped liquid is neither abrasive nor corrosive.

PACKING

When the pump is intended to be equipped with shaft packing, it is not American-Marsh’s standard practice to install the packing in the stuffing box prior to shipment. The packing is shipped with the pump. It is the pump installer’s responsibility to install the packing in the stuffing box.



Failure to ensure that packing is installed may result in serious leakage of the pumped fluid.

PIPING CONNECTION –SEAL/ PACKING SUPPORT SYSTEM



If the pump has a seal support system, it is mandatory that this system be fully installed and operational before the pump is started.

If packing is used:

Packing Lubrication – Water, when compatible with the pumpage, should be introduced into the packing box at pressure 10 to 15 lbf/in² (69 to 103 kPa) above the stuffing box pressure.

The gland should be adjusted to give a flow rate of 20 to 30 drops per minute for clean fluid. For abrasive applications, the regulated flow rate should be 1-2 gpm (0.06-0.13 l/s).

Grease lubrication, when compatible with the pumpage, may be used. In non-abrasive applications the pumpage itself may be sufficient to lubricate the packing without need for external lines. The internal flush line should be plugged.

Abrasive Packing Arrangement – The installation procedures are the same as the standard packing with some exceptions. A special lip seal is installed first, followed by two lantern ring assemblies, then two of the packing rings provided.

A flush line from a clean external source should be connected to the top of the stuffing box.

BEARING LUBRICATION

Grease lubricated ball bearings are packed with grease at the

factory and ordinarily will require no attention before starting, provided the pump has been stored in a clean, dry place prior to its first operation. The bearings should be watched the first hour or so after the pump has been started to see that they are operating properly.

The importance of proper lubrication cannot be over emphasized. It is difficult to say how often a bearing should be greased, since that depends on the conditions of operation. It is well to add one ounce of grease at regular intervals, but it is equally important to avoid adding too much grease. For average operating conditions, it is recommended that 1 oz. of grease be added at intervals of three to six months, and only clean grease be used. It is always best if unit can be stopped while grease is added to avoid overloading.



Excess grease is the most common cause of overheating.

A lithium based NLGI-2 grade grease should be used for lubricating bearings where the ambient temperature is above -20°F. Grease lubricated bearings are packed at the factory with Royal Purple NLGI #2. Other recommended greases are Texaco Multifak 2, Shell Alvania 2 and Mobilux No. 2 grease. Greases made from animal or vegetable oils are not recommended due to the danger of deterioration and forming of acid. Do not use graphite. Use of an ISO VG 100 mineral base oil with rust and oxidation inhibitors is recommended.

The maximum desirable operating temperature for ball bearings is 180°F. Should the temperature of the bearing frame rise above 180°F, the pump should be shut down to determine the cause.

Mineral Oil	Quality mineral oil with rust and oxidation inhibitors. Mobil DTE Heavy/Medium ISO VG 68 or equivalent.
Synthetic	Royal Purple SynFilm 68, Conoco SYN-CON 68 or equivalent. Some synthetic lubricants require Viton O-rings.
Grease	Royal Purple NLGI #2, Chevron SRI #2 (or compatible).

FIGURE 5 – Recommended Lubricants

Maximum Oil Temperature	ISO Viscosity Grade	Minimum Viscosity Index
Up to 160°F (71°C)	46	95
160-175°F (71°-80°C)	68	95
175-200°F (80°-94°C)	100	95

FIGURE 6 – Oil Viscosity Grades

Lubricant	Under 60°F (71°C)	160-175°F (71-80°C)	175-200°F (80-94°C)
Grease	6 mo	3 mo	1.5 mo
Mineral Oil	6 mo	3 mo	1.5 mo
Synthetic Oil**	18 mo	18 mo	18 mo

FIGURE 7 – Re-lubrication Intervals

COUPLING

A direction arrow is cast on the casing. Make sure the motor rotates in the same direction before coupling the motor to the Pump.

It is absolutely essential that the rotation of the motor be checked before connecting the shaft coupling. Incorrect rotation of the pump, for even a short time, can dislodge the shaft sleeves which may cause serious damage to the pump.

The coupling should be installed as advised by the coupling manufacturer. Pumps are shipped without the spacer installed. If the spacer has been installed to facilitate alignment, then it must be removed prior to checking rotation. Remove protective material from the coupling and any exposed portions of the shaft before installing the coupling.

PUMP OPERATION

ROTATION CHECK



It is absolutely essential that the rotation of the motor be checked before connecting the shaft coupling. Incorrect rotation of the pump, for even a short time, can dislodge and damage the shaft sleeves, impeller, casing, shaft and shaft seal.

HD pumps can turn clockwise or counter-clockwise and therefore rotation must be specified at time of order.

PRE START-UP CHECKS

Prior to starting the pump it is essential that the following checks are made. These checks are all described in detail in the Maintenance Section of this booklet.

- Pump and Motor properly secured to the base plate
- Check alignment of pump and motor
- Coupling guard in place and not rubbing
- Rotation check, see above

THIS IS ABSOLUTELY ESSENTIAL

- Shaft seal and/or packing properly installed
- Seal support system operational
- Bearing lubrication
- Pump instrumentation is operational
- Pump is primed
- Rotation of shaft by hand

As a final step in preparation for operation, it is important to rotate the shaft by hand to be certain that all rotating parts move freely, and that there are no foreign objects in the pump.

PRIMING

If the pump is installed with a positive head on the suction, it can be primed by opening the suction and vent valve and allowing the liquid to enter the casing. If the pump is installed with a suction lift, priming must be done by other methods such as foot valves, ejectors, or by manually filling the casing and suction line.

ENSURING PROPER NPSHA

Net Positive Suction Head – Available (NPSHA) is the measure of the energy in a liquid above the vapor pressure. It is used to determine the likelihood that a fluid will vaporize in the pump. It is critical because a centrifugal pump is designed to pump a liquid, not a vapor. Vaporization in a pump will result in damage to the pump, deterioration of the Total Differential Head (TDH), and possibly a complete stopping of pumping.

Net Positive Suction Head – Required (NPSHR) is the decrease of fluid energy between the inlet of the pump, and the point of lowest pressure in the pump. This decrease occurs because of friction losses and fluid accelerations in the inlet region of the pump, and particularly accelerations as the fluid enters the impeller vanes. The value for NPSHR for the specific pump purchased is given in the pump data sheet, and on the pump performance curve.

For a pump to operate properly the NPSHA must be greater than the NPSHR. Good practice dictates that this margin should be at least 5 ft (1.5 m) or 20%, whichever is greater.



Ensuring that NPSHA is larger than NPSHR by the suggested margin will greatly enhance pump performance and reliability. It will also reduce the likelihood of cavitation, which can severely damage the pump.

MINIMUM FLOW

Minimum continuous stable flow is the lowest flow at which the pump can operate and still conform to the bearing life, shaft deflection and bearing housing vibration limits of the ASME standard. Pumps may be operated at lower flows, but it must be recognized that the pump may not conform to one or more of these limits. For example, vibration may exceed the limit set by the ASME standard. The size of the pump, the energy absorbed, and the liquid pumped are some of the considerations in determining the minimum flow.

Typically, limitations of 20% of the capacity at the best efficiency point (BEP) should be specified as the minimum flow. However, American-Marsh has determined that several pumps must be limited to higher minimum flows to provide optimum service. The following are the recommended minimum flows for these specific pumps:

Pump Size	60 Hz		50 Hz	
	RPM	Minimum Flow (% of BEP)	RPM	Minimum Flow (% of BEP)
Module 1	3500	25%	2900	21%
Module 1	1750	25%	1450	21%
Module 2	3500	25%	2900	21%
Module 2	1750	33%	1450	28%
All Other Sizes	ANY	15%	ANY	15%

FIGURE 8 - Minimum Continuous Safe Flow

Note: “Minimum intermittent flow” value of 50% of the “minimum continuous flow” as long as that flow is greater than the “minimum thermal flow.”

All HD pumps also have a “Minimum Thermal Flow.” This is defined as the minimum flow that will not cause an excessive temperature rise. Minimum Thermal Flow is application

dependent.



Do not operate the pump below Minimum Thermal Flow, as this could cause an excessive temperature rise. Contact an American-Marsh Sales Engineer for determination of Minimum Thermal flow.

STARTING THE PUMP AND ADJUSTING FLOW

1. Open the suction valve to full open position. It is very important to leave the suction valve open while the pump is operating. Any throttling or adjusting of flow must be done through the discharge valve. Partially closing the suction valve can create serious NPSH and pump performance problems.



Never operate pump with both the suction and discharge valves closed. This could cause an explosion.

2. A standard centrifugal pump will not move liquid unless the pump is primed. A pump is said to be “primed” when the casing and the suction piping are completely filled with liquid. Open discharge valve a slight amount. This will allow any entrapped air to escape and will normally allow the pump to prime, if the suction source is above the pump. When a condition exists where the suction pressure may drop below the pump’s capability, it is advisable to add a low pressure control device to shut the pump down when the pressure drops below a predetermined minimum.

3. All cooling, heating, and flush lines must be started and regulated.

4. Start the driver (typically, the electric motor).

5. Slowly open the discharge valve until the desired flow is reached, keeping in mind the minimum flow restrictions listed above.



It is important that the discharge valve be opened within a short interval after starting the driver. Failure to do this could cause a dangerous build up of heat, and possibly an explosion.

6. Reduced capacity

Avoid running a centrifugal pump at drastically reduced capacities or with discharge valve closed for extended periods of time. This can cause severe temperature rise and the liquid in the pump may reach its boiling point. If this occurs, the mechanical seal will be exposed to vapor, with no lubrication, and may score or seize to the stationary parts. Continued running under these conditions when the suction valve is also closed, can create an explosive condition due to the confined vapor at high pressure and temperature. Thermostats may be used to safeguard against over heating by shutting down the pump at a predetermined temperature.

Safeguards should also be taken against possible operation with a closed discharge valve, such as installing a bypass back to the suction source. The size of the bypass line and the required bypass flow rate is a function of the input horsepower and the allowable temperature rise.

7. Reduced Head

Note that when discharge head drops, the pump’s flow rate usually increases rapidly. Check motor for temperature rise as this may cause overload. If overloading occurs, throttle the discharge.

8. Surging Condition

A rapidly closing discharge valve can cause a damaging pressure surge. A dampening arrangement should be provided in the piping.

OPERATION IN SUB-FREEZING CONDITIONS

When using the pump in sub-freezing conditions where the pump is periodically idle, the pump should be properly drained or protected with thermal devices which will keep the liquid in the pump from freezing. High chrome iron pumps are not recommended for applications below 0°F (-18°C).

SHUTDOWN CONSIDERATIONS

When the pump is being shutdown, the procedure should be the reverse of the start-up procedure.

discharge valve, shutdown the driver, then close the suction valve. Remember, closing the suction valve while the pump is running is a safety hazard and could seriously damage the pump and other equipment.

TROUBLESHOOTING

The following is a guide to troubleshooting problems with American-Marsh pumps. Common problems are analyzed and solutions are offered. Obviously, it is impossible to cover every possible scenario. If a problem exists that is not covered by one of the examples, then contact a local American-Marsh Sales Engineer or Distributor/Representative for assistance.

PROBLEM	POSSIBLE CAUSE	RECOMMENDED REMEDY
Problem #1 Pump not reaching design flow rate.	1.1 Insufficient NPSHA. (Noise may not be present)	Recalculate NPSH available. It must be greater than the NPSH required by pump at desired flow. If not, redesign suction piping, holding number of elbows and number of planes to a minimum to avoid adverse flow rotation as it approaches the impeller.
	1.2 System head greater than anticipated.	Reduce system head by increasing pipe size and/ than or reducing number of fittings. Increase impeller diameter. NOTE: Increasing impeller diameter may require use of a larger motor.
	1.3 Entrained air.	Air leak from atmosphere on suction side. 1. Check suction line gaskets and threads for tightness. 2. If vortex formation is observed in suction tank, install vortex breaker. 3. Check for minimum submergence.
	1.4 Entrained gas from process.	Process generated gases may require larger pumps.
	1.5 Speed too low.	Check motor speed against design speed.
	1.6 Direction of rotation wrong.	After confirming wrong rotation, reverse any two of three leads on a three phase motor. The pump should be disassembled and inspected before it is restarted.
	1.7 Impeller too small.	Replace with proper diameter impeller. NOTE: Increasing impeller diameter may require use of a larger motor.
	1.8 Impeller clearance too large.	Replace impeller and/or case wear rings.
	1.9 Plugged impeller, suction line or casing which may be due to a product or large solids.	1. Reduce length of fiber when possible. 2. Reduce solids in the process fluid when possible. 3. Consider larger pump.
	1.10 Wet end parts (casing cover, impeller) worn, corroded or missing.	Replace part or parts.
Problem #2.0 Pump not reaching design head (TDH).	2.1 Refer to possible causes under Problem #1.0.	Refer to remedies listed under Problem #1.0 and #3.0.
Problem #3.0 No discharge or flow	3.1 Not properly primed.	Repeat priming operation, recheck instructions. If pump has run dry, disassemble and inspect the pump before operation.

PROBLEM	POSSIBLE CAUSE	RECOMMENDED REMEDY
Cont. Problem #3.0 No discharge or flow	3.2 Direction of rotation wrong.	After confirming wrong rotation, reverse any two of three leads on a three phase motor. The pump should be disassembled and inspected before operation.
	3.3 Entrained air.	Air leak from atmosphere on suction side. Refer to recommended remedy under Problem #1.0, Item #1.3.
	3.4 Plugged impeller, suction line or casing which may be due to a fibrous product or large solids.	Refer to recommended remedy under Problem #1.0, Item #1.9.
	3.5 Damaged pump shaft, impeller.	Replace damaged parts.
Problem #4.0 Pump operates for short period, then loses prime.	4.1 Insufficient NPSH.	Refer to recommended remedy under Problem #1.0, Item #1.1.
	4.2 Entrained air.	Air leak from atmosphere on suction side. Refer to recommended remedy under Problem #1.0, Item #1.1.
Problem #5.0 Excessive noise from wet end.	5.1 Cavitation - insufficient NPSH available.	Refer to recommended remedy under Problem #1.0, Item #1.1.
	5.2 Abnormal fluid rotation due to complex suction piping.	Redesign suction piping, holder number of elbows and number of planes to a minimum to avoid adverse fluid rotation as it approaches the impeller.
	5.3 Impeller rubbing.	1. Replace impeller and/or case wear rings. 2. Check outboard bearing assembly for axial end play.
Problem #6.0 Excessive noise from bearings.	6.1 Bearing contamination appearing on the raceways as scoring, pitting, scratching, or rusting caused by adverse environment and entrance of abrasive contaminants from atmosphere.	1. Work with clean tools in clean surroundings. 2. Remove all outside dirt from housing before exposing bearings. 3. Handle with clean dry hands. 4. Treat a used bearing as carefully as a new one. 5. Use clean solvent and flushing oil. 6. Protect disassembled bearing from dirt and moisture. 7. Keep bearings wrapped in paper or clean cloth while not in use. 8. Clean inside of housing before replacing bearings. 9. Check oil seals and replace as required. 10. Check all plugs and tapped openings to make sure that they are tight.

PROBLEM	POSSIBLE CAUSE	RECOMMENDED REMEDY
<p>Cont. Problem #6.0 Excessive noise from bearings.</p>	<p>6.2 Brinelling of bearing identified by indentation on the ball races, usually caused by incorrectly applied forces in assembling the bearing or by shock loading such as hitting the bearing or drive shaft with a hammer.</p>	<p>When mounting the bearing on the outboard end use a proper size ring and apply the pressure against the inner ring only. Be sure when mounting a bearing to apply the mounting pressure slowly and evenly.</p>
	<p>6.3 False brinelling of bearing identified again by either axial or circumferential indentations usually caused by vibration of the balls between the races in a stationary bearing.</p>	<ol style="list-style-type: none"> 1. Correct the source of vibration. 2. Where bearings are oil lubricated and employed in units that may be out of service for extended periods, the drive shaft should be turned over periodically to re-lubricate all bearing surfaces at intervals of one-to three months.
	<p>6.4 Thrust overload on bearing identified by flaking ball path on one side of the outer race or in the case of maximum capacity bearings, may appear as a spalling of the races in the vicinity of the loading slot. (Please note: maximum capacity bearings are not recommended in HD pumps.) These thrust failures are caused by improper mounting of the bearing or excessive thrust loads.</p>	<ol style="list-style-type: none"> 1. Follow correct mounting procedures for bearings.
	<p>6.5 Misalignment identified by fracture of ball retainer or a wide ball path on the inner race and a narrower cocked ball path on the outer race. Misalignment is caused by poor mounting practices or defective drive shaft. For example bearing not square with the centerline or possibly a bent shaft due to improper handling.</p>	<p>Handle parts carefully and follow recommended mounting procedures. Check all parts for proper fit and alignment.</p>
	<p>6.6 Bearing damaged by electric arcing identified as electro-etching of both inner and outer ring as a pitting or cratering. Electrical arcing is caused by a static electrical charge emanating from belt drives, electrical leakage or short circuiting.</p>	<ol style="list-style-type: none"> 1. Where current shunting through the bearing cannot be corrected, a shunt in the form of a slip ring assembly should be incorporated. 2. Check all wiring, insulation and rotor windings to be sure that they are sound and all connections are properly made. 3. Where pumps are belt driven, consider the elimination of static charges by proper grounding or consider belt material that is less generative.

PROBLEM	POSSIBLE CAUSE	RECOMMENDED REMEDY
<p>Cont. Problem #6.0 Excessive noise from bearings.</p>	<p>6.7 Bearing damage due to improper lubrication, identified by one or more of the following:</p> <ol style="list-style-type: none"> 1. Abnormal bearing temperature rise. 2. A stiff cracked grease appearance. 3. A brown or bluish discoloration of the bearing races. 	<ol style="list-style-type: none"> 1. Be sure the lubricant is clean. 2. Be sure proper amount of lubricant is used. The constant level oiler supplied with HD pumps will maintain the proper oil level if it is installed and operating properly. In the case of greased lubricated bearings, be sure that there is space adjacent to the bearing into which it can rid itself of excessive lubricant, otherwise the bearing may overheat and fail prematurely. 3. Be sure the proper grade of lubricant is used.

MAINTENANCE

PREVENTIVE MAINTENANCE

The following sections of this manual give instructions on how to perform a complete maintenance overhaul. However, it is also important to periodically repeat the “Pre start-up checks” listed on page 14. These checks will help extend pump life as well as the length of time between major overhauls.

NEED FOR MAINTENANCE RECORDS

A procedure for keeping accurate maintenance records is a critical part of any program to improve pump reliability. There are many variables that can contribute to pump failures. Often long term and repetitive problems can only be solved by analyzing these variables through pump maintenance records.

NEED FOR CLEANLINESS

One of the major causes of pump failure is the presence of contaminants in the bearing housing. This contamination can be in the form of moisture, dust, dirt and other solid particles such as metal chips. Contamination can also be harmful to the mechanical seal (especially the seal faces) as well as other parts of the pumps. For example, dirt in the shaft threads could cause the impeller to not be seated properly against the shaft sleeve. This, in turn, could cause a series of other problems. For these reasons, it is very important that proper cleanliness be maintained. Some guidelines are listed below.

If it is contaminated, determine the cause and correct. The work area should be clean and free from dust, dirt, oil, grease, etc. Hands and gloves should be clean. Only clean towels, rags, and tools should be used.

MAINTENANCE OF PUMP DUE TO FLOOD DAMAGE

The servicing of centrifugal pumps after a flooded condition is a comparatively simple matter under normal conditions.

Bearings are a primary concern on pumping units. First, dismantle the bearings; clean and inspect them for any rusted or badly worn surfaces. If bearings are free from rust and wear, re-assemble and re-lubricate them with one of the recommended pump lubricants. Depending on the length of time the pump has remained in the flooded area, it is unlikely that bearing replacement is necessary; however, in the event that rust or worn surfaces appear, it may be necessary to replace the bearings.

Next, inspect the stuffing box, and clean out any foreign matter

that might clog the box. Mechanical seals should be cleaned and thoroughly flushed.

Couplings should be dismantled and thoroughly cleaned.

Any pump that is properly sealed at all joints and connected to both the suction and discharge should exclude outside liquid.

Therefore, it should not be necessary to go beyond the bearings, stuffing box, and coupling when servicing the pump.

ROUTINE MAINTENANCE CHART	
Every Week	Visually check for leaks Check for lubrication Adjust glands as necessary to maintain proper leakage Hand test bearing housing for any sign of temperature rise
Every Month	Check bearing temperature with a thermometer
Every 6 Months	Check the packing and replace if necessary Check alignment of the pump and motor Check holding down bolts for tightness Check coupling for wear
Every Year	Check rotating element for wear Check wear ring clearances Check and regrease bearings Measure total dynamic suction and discharge head

FIGURE 9 - Routine Maintenance Chart

DISASSEMBLY

Refer to the parts list shown in Figure 19 for item number references used throughout this section.

1. Before performing any maintenance, disconnect the driver from its power supply and lock it off line.



Lock out power to driver to prevent personal injury.

2. Close the discharge and suction valves, and drain all liquid from the pump.
3. Close all valves on auxiliary equipment and piping, then disconnect all auxiliary piping.
4. Decontaminate the pump as necessary. If American-Marsh pumps contain dangerous chemicals, it is important to follow plant safety guidelines to avoid personal injury or death.
5. Remove the coupling guard.
6. Remove the spacer coupling and drive key.
7. Drain the pump by removing the vent plug at the top of the casing (#1A).
8. Remove the fasteners holding the upper casing (#1A) to the lower casing (#1A). Remove any external piping if supplied. Remove the two (2) casing dowel pins from the casing assembly.
9. Insert a screwdriver or pry bar into the slots between the upper (#1A) and lower (#1A) casing halves and separate the halves, lifting off the upper (#1A) casing half. Discard the casing gasket (#353A).

14. Remove outboard lip seal (#104N) and discard. Remove inboard lip seal (#104P) and discard.
15. Remove the outboard and inboard bearing spacers (#45A).

DISASSEMBLY OF PACKED PUMPS

16. Remove four cap screws that hold the outboard bearing arm (#86N) and inboard bearing arm (#86P) to the stuffing box (#1B). Loosen and remove gland nuts (#72C) from the outboard and inboard locations. Remove bearing arms (#86N & #86P) and gland assemblies (#71A) from outboard and inboard locations.
17. Slide outboard and inboard stuffing boxes (#1B) off of shaft assembly.
18. Remove and discard all rings of packing (#331A), since replacement with new packing is recommended whenever pump is disassembled. Be sure to remove all packing from the stuffing box. Remember there are rings of packing behind the lantern ring (#73A). Inspect the lantern ring (#73A) for damage and replace if necessary.
19. Remove both casing wear rings (#15A) from impeller (#11D).

Right-Hand Rotation

20. Unscrew shaft sleeve (#42A) from the outboard end and slide off of shaft (#41A). Discard shaft sleeve o-ring (#331C).

Left-Hand Rotation

21. Unscrew shaft sleeve (#42A) from the inboard end and slide off of shaft (#41A). Discard shaft sleeve o-ring (#331C).
22. Remove the impeller (#11D), slide back the impeller key (#24A) and remove the other shaft sleeve (#42A). Discard shaft sleeve o-ring (#331C). Remove the impeller key (#24A) from shaft (#41).

DISASSEMBLY OF MECHANICALLY SEALED PUMPS

23. Slide outboard and inboard seal chambers (#1B) off of shaft assembly.
24. Drive the mechanical seal stationary out of seal chamber (#1B).
25. Slide the rotating elements of the mechanical seal



The upper casing (#1A) is heavy. It is important to follow plant safety guidelines when lifting it.

10. Lightly tap the stuffing boxes (#1B) with a soft headed hammer to break the seal between the stuffing box (#1B) and the lower casing (#1A). Lift the rotating assembly out of the lower casing half (#1A). Discard the stuffing box o-rings (#331D).
11. Remove the four cap screws (384B) from each bearing housing cap (#82N & #82P).
12. Remove the locknut (#89N) and lockwasher (#91N) from the outboard end of the shaft (#41). Using a puller, pull the outboard bearing (#81N) from the shaft (#41) and discard.
13. Using a puller, pull the inboard bearing (#81P) from the shaft (#41) and discard.

NOTE: Locknut and lockwasher are not used on inboard end of shaft.

(#331B) off of the shaft (#41A).

26. Remove both casing wear rings (#15A) from impeller (#11D).

Right-Hand Rotation

27. Unscrew shaft sleeve (#42A) from the outboard end and slide off of shaft (#41A).

Left-Hand Rotation

28. Unscrew shaft sleeve (#42A) from the inboard end and slide off of shaft (#41A). Discard shaft sleeve o-ring (#331C).

29. Remove the impeller (#11D), slide back the impeller key (#24A) and remove the other shaft sleeve (#42A). Discard shaft sleeve o-ring (#331C). Remove the impeller key (#24A) from shaft (#41).

RE-ASSEMBLY

BEARING INSTALLATION

Mounting of bearings on shafts must be done in a clean environment. Bearing and power end life can be drastically reduced if even very small foreign particles work their way into the bearings.

Bearings should be removed from their protective packaging only immediately before assembly to limit exposure to possible contamination. After removing the packaging they should only come in contact with clean hands, fixtures, tools and work surfaces.

The chart shown in Figure 10 gives the SKF part numbers for bearings in American-Marsh HD pumps. Note that the term “inboard bearing” refers to the bearing nearest to the motor. “Outboard bearing” refers to the bearing farthest from the motor.

Module	Type of Bearings	Inboard Single Row, Deep Groove ^⑤	Outboard Single Deep Groove ^⑤
1, 2, 3	Oil bath/mist – Open ^① Regreasable – Single Shielded ^② Greased for life – Double Shielded ^③ Sealed for life – Double Sealed ^④	6306-C3 6306-ZC3 6306-2ZC3 6306-2RSIC3	6306-C3 6306-ZC3 6306-2ZC3 6306-2RSIC3
4, 5, 6	Oil bath/mist – Open ^① Regreasable – Single Shielded ^② Greased for life – Double Shielded ^③ Sealed for life – Double Sealed ^④	6309-C3 6309-ZC3 6309-2ZC3 6309-2RSIC3	6309-C3 6309-ZC3 6309-2ZC3 6309-2RSIC3
7	Oil bath/mist – Open ^① Regreasable – Single Shielded ^② Greased for life – Double Shielded ^③ Sealed for life – Double Sealed ^④	6312-C3 6312-ZC3 6312-2ZC3 6312-2RSIC3	6312-C3 6312-ZC3 6312-2ZC3 6312-2RSIC3

FIGURE 10 – AMP HD Bearings

①These bearings are open on both sides. They are lubricated by oil bath or oil mist.

②These bearings are pre-greased by American-Marsh. Replacement bearings will generally not be pre-greased, so grease must be applied by the user. They have a single shield, which is located on the side next to the grease buffer, or reservoir. The bearings draw grease from the reservoir as it is needed. The shield protects the bearing from getting too much grease, which would generate heat. The grease reservoir is initially filled with grease by American-Marsh. Lubrication fittings are provided, to allow the customer to periodically replenish the grease, as recommended by the bearing and/or grease manufacturer.

③These bearings are shielded on both sides. They come pre-greased by the bearing manufacturer. The user does not need to re-grease these bearings. The shields do not actually contact the bearing race, so no heat is generated.

④These bearings are sealed on both sides. They come pre-greased by the bearing manufacturer. The user does not need to re-grease these bearings. The seals physically contact and rub against the bearing race, which generates heat. These bearings are not recommended at speeds above 1750 RPM.

⑤The codes shown are SKF codes. Inboard and outboard bearings have the C3, greater than “Normal” clearance. These clearances are recommended by SKF to maximize bearing life.

⑥Re-greasable – Single Shielded bearings are not available in the duplex configuration; however, open oil bath-type bearings can be used for the re-greasable configuration. These bearings must be pre-greased during assembly. Lubrication fittings are provided, to allow the user to periodically replenish the grease, as recommended by the bearing and/or grease manufacturer.

⑦Not available.

RE-ASSEMBLY OF PUMPS

RIGHT-HAND ROTATION

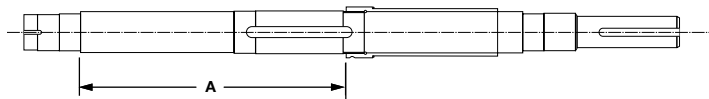

Pump Model	Mechanical Seal	Packed
	A – Inches	
2.5x3-10 HD	7.813	11.125
3x4-10 HD	7.813	11.125
4x6-10 HD	10.000	14.000
5x6-10 HD	9.938	13.250
6x8-10 HD	9.938	13.250
10x10-10 HD	12.500	16.313
5x6-11 HD	7.813	11.125
3x4-12 HD	7.813	11.125
4x5-12 HD	7.813	11.125
5x6-12 HD	9.938	13.250
6x8-12 HD	10.063	14.000
8x10-12 HD	12.500	16.313
10x10-12 HD	12.500	16.313
2x3-15 HD	7.813	11.125
3x4-15 HD	7.813	11.125
4x5-15 HD	10.063	14.000
5x6-15 HD	10.063	14.000
6x8-15 HD	10.063	14.000
8x10-15 HD	13.000	16.500
10x12-15 HD	13.000	16.500
4x5-18 HD	10.000	14.000
5x6-18 HD	13.000	16.500
6x8-18 HD	13.000	16.500
8x10-18 HD	13.000	16.500
10x12-18 HD	15.688	16.500

FIGURE 11 - Right-Hand Shaft Sleeve Dimensions

1. Place new shaft sleeve o-rings (#331C) onto shaft sleeves (#41A).
2. Wipe over shaft (#41A) with clean light oil. Screw shaft sleeve (#42A) onto shaft (#41A) at the inboard location until the non threaded end of the shaft sleeve (#41A) is properly lined up with the step on the shaft (#41A). See Figure 11.
3. Place impeller key (#24A) into shaft keyway and tap milled-down end under the shaft sleeve (#42A).

4. Check impeller (#11D) for correct rotation (See Figure 12) and slide onto shaft (#41A) from outboard end.

5. Screw the second shaft sleeve (#42A) onto the shaft (#41A) locking it tight up against the impeller (#11D) and the first shaft sleeve (#42A).

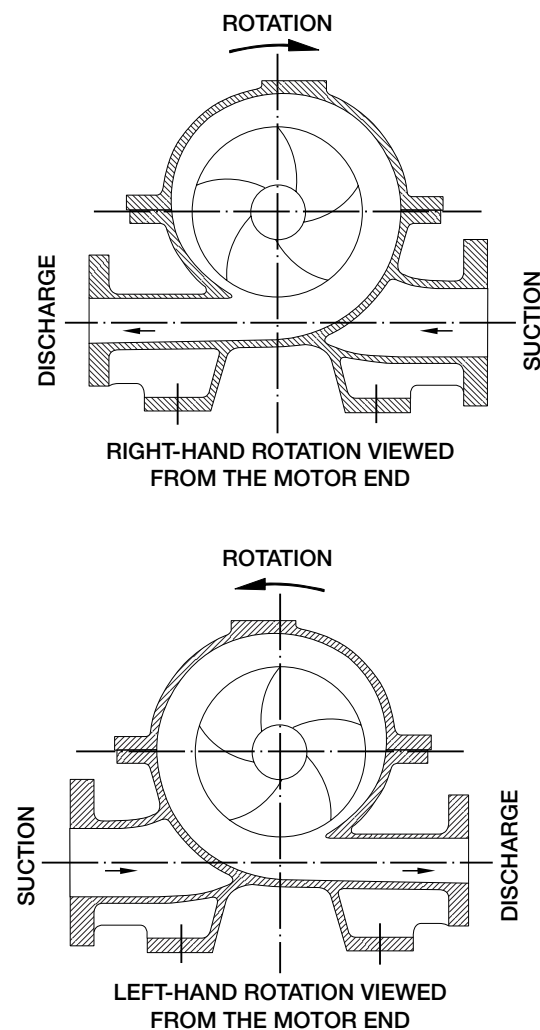

FIGURE 12 - Proper Impeller Rotation

6. Slide both case wear rings (#15A) onto the impeller (#11D).
7. Lubricate and roll the seal chamber o-ring (#331D) into the groove of the seal chamber (#1B).
8. Pre-lubricate the rotary part of the mechanical seal (#331B) and slide the mechanical seals onto the shaft (#41) from both the outboard and inboard locations.
9. Press the stationary seal face (#331B) into the seal chamber (#1B).

IF USING MECHANICAL SEALS

10. Slide the seal chamber (#1B) up onto the shaft assembly, taking care not to damage the shaft sleeves (#42A) or the stationary seal face keeping the vortex suppressor at the top, 12 o'clock position.

IF USING PACKING

11. Lubricate and roll the stuffing box o-ring (#331D) into the groove of the stuffing box (#1B).

12. Slide the stuffing boxes (#1B) up onto the shaft assembly, taking care not to damage the shaft sleeves (#42A) keeping the vortex suppressor at the top, 12 o'clock position. Install packing per **INSTALLING STUFFING BOX PACKING** on Page 26.

13. Slide the gland assemblies (#71A) and the bearing arms (#86N & #86P) onto the shaft (#41A) simultaneously and secure bearing arm (#86N) to stuffing boxes (#1B) with four cap screws. Secure and tighten the glands (#71A) with the gland nuts (#72C) as described in Section **INSTALLING STUFFING BOX PACK-**

ING on Page 26.

14. Slide the bearing adapters (#45A) onto the shaft. Press the oil lipseals (#104N & #104P) into the seal chambers (#1B).

15. Heat the outboard ball bearing (#81N) to approximately 212°F (100°C) using a bearing hot plate or lubricating oil bath.

Do not exceed 248°F (120°C). Temperatures in excess of this will permanently damage ball bearing.

16. Slide the heated bearing (#81N) onto the shaft (#41A) until it abuts the bearing adapter (#45A). Place the lockwasher (#91N) onto the shaft (#41A) and lock the bearing locknut (#89N) tight against the bearing (#81N).

17. Cool the bearing to room temperature and coat both sides with two to three ounces of recommended grease.

18. Coat the inside of the bearing housing (#82N) with



grease and slide into place over the bearing (#81N). Slight tapping of the bearing housing may be necessary as there are fairly tight tolerances between the bearing (#81N) and the bearing housing (#82N). Secure the bearing housing (#82N) to the bearing arm (#86N) with the four hex head capscrews (#384B).

19. Heat the inboard ball bearing (#81P) to approximately 212°F (100°C) using a bearing hot plate or lubricating oil bath.

Do not exceed 248°F (120°C). Temperatures in excess of this will permanently damage ball bearing.

20. Cool the bearing (#81P) to room temperature and coat both sides with two to three ounces of recommended grease.

21. Coat the inside of the bearing housing (#82N) with grease and slide into place over the bearing (#81N). Slight tapping of the bearing housing may be necessary as there are fairly tight tolerances between the bearing (#81N) and the bearing housing (#82N). Secure the bearing housing (#82N) to the bearing arm (#86N) with the four hex head capscrews (384B).

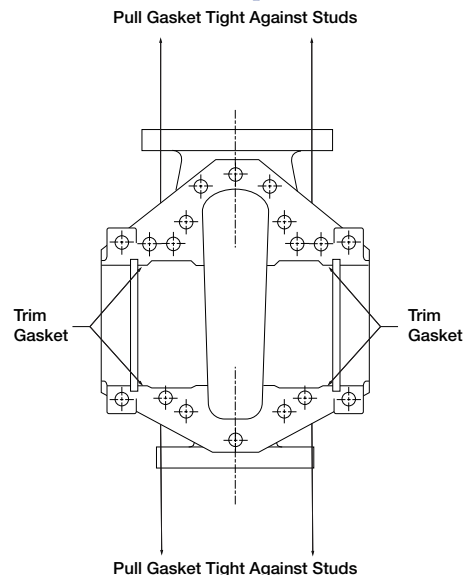

22. Place the casing gaskets (#353A) on the pump casing half (#1A). Pull the gaskets tight against the casing studs (#381B). Trim the four areas of the gasket (#353A) where the stuffing box o-ring (#331D) meets the gasket (#353A) flush with the casing (#1A). See Figure 13. Remove the gaskets.



FIGURE 13 – Casing Gasket Orientation

23. Set the rotating assembly into the bottom half of the casing (#1A). Align the pins (#16A) for the case wear rings (#15A) and the pins (#16B) for the stuffing boxes (#1B) so the rotor assembly drops down into the lower half of the casing (#1A). Ensure that the stuffing box o-rings (#331D) are not pinched or buckled. Check to make sure the impeller (#11D) is located in a central position within the casing (#1A) and between the case wear rings (#15A). The rotor assembly should rotate freely at this point. If this is not the case, the binding point must be located and eliminated. Disassembly of the rotor assembly may need to occur. If the impeller (#11D) is not located properly within the casing (#1A), the shaft sleeves (#42A) may need to be shifted to reorient the impeller (#11D) (left or right).

24. Install the gaskets (#353A) with a light spot of RTV fast curing silicone at the inner edge where the casing gasket (#353A) meets the stuffing box o-ring (#331D). This will assure a good seal. It is imperative that the case gasket (#353A) is cut flush with the bore in the casing (#1A). If the case gasket (#353A) is not cut and installed in contact with the stuffing box o-ring (#331D) water could leak around this o-ring (#331D).

25. Lower the upper half of the casing (#1A) into place and install the casing nuts (#381B).

26. Insert the casing joint dowels. Tighten the casing nuts (#381B) to the proper torque rating per the following table.

BOLT SIZE		TIGHTENING TORQUE	
Metric	Standard	Lbf-ft	Nm
4 mm	5/32"	2.7	3.6
5 mm	3/16"	5.2	7.0
6 mm	1/4"	8.9	12.0
7 mm	9/32"	14.6	19.8
8 mm	5/16"	21.8	29.6
9 mm	11/32"	28.0	38.0
10 mm	3/8"	38.7	52.5
12 mm	1/2"	65.6	89.0
14 mm	9/16"	99.6	135
16 mm	5/8"	151	205
18 mm	11/16"	190	257
20 mm	3/4"	264	358
22 mm	7/8"	321	435
24 mm	15/16"	411	557

FIGURE 14 – Casing Nut Torque Values

27. Install external flush piping, if supplied. Rotate the shaft by hand to assure smooth turning and that it is free from rubbing or binding.

INSTALLING STUFFING BOX PACKING

Refer to Figure 15 for number of packing rings required by pump model.

If packing is to be cut from a coil or long length:

1. Wrap the packing around a dummy shaft, equal to the shaft sleeve diameter.
2. To assist in cutting rings, two guides lines parallel to the shaft axis and separated by a distance equal to the packing section may be drawn on the spiral.
3. Cut the rings from the spiral at an angle of 45° diagonally across the guide lines. No gap is left between the ends.

Insert the first ring and tap it to the bottom of the stuffing box. Each following ring should be installed in the same manner and positioned in the stuffing box so that the split is advanced 90°.

Install the lantern ring in its proper position to align with the internal flush connection allowing for movement of the ring deeper into the box as the packing is compressed.

When the correct number of rings have been inserted, the last packing ring should not protrude past the stuffing box face, so that the gland may be properly started in the stuffing box bore.

Bring the gland follower up squarely against the last packing ring and tighten the nuts evenly to finger pressure. Turn the shaft to ensure it does not bind on the bore of the gland assembly.

Pressurize the stuffing box, ensuring air is not trapped. A packed gland must leak and leakage should take place commencing soon after the stuffing box is pressurized.

Until steady leakage takes place, the pump may overheat. If this happens, the pump must be stopped and allowed to cool and, when re-started, leakage should take place. If it does not, this operation should be repeated. Gland nuts (#72C) should not be slackened.

After the pump has been running for ten (10) minutes with steady leakage, tighten the gland nuts (#72C) by one sixth of a full turn. Continue to adjust at ten (10) minutes intervals, each time evenly by one sixth of a full turn, until the leaking is reduced to an acceptable level.

Pump Model	Stuffing Box Information		
	Bore	Depth	Packing
2.5x3-10 HD	2.559	2.362	8 - 3/8" SQ
3x4-10 HD	2.559	2.362	8 - 3/8" SQ
4x6-10 HD	3.347	2.756	8 - 1/2" SQ
5x6-10 HD	2.559	2.362	8 - 3/8" SQ
6x8-10 HD	2.559	2.362	8 - 3/8" SQ
10x10-10 HD	3.347	2.795	8 - 1/2" SQ
5x6-11 HD	2.559	2.362	8 - 3/8" SQ
3x4-12 HD	2.559	2.362	8 - 3/8" SQ
4x5-12 HD	2.559	2.362	8 - 3/8" SQ
5x6-12 HD	2.559	2.362	8 - 3/8" SQ
6x8-12 HD	3.347	2.795	8 - 1/2" SQ
8x10-12 HD	3.347	2.795	8 - 1/2" SQ
10x10-12 HD	3.347	2.795	8 - 1/2" SQ
2x3-15 HD	2.559	2.362	8 - 3/8" SQ
3x4-15 HD	2.559	2.362	8 - 3/8" SQ
4x5-15 HD	3.347	2.756	8 - 1/2" SQ
5x6-15 HD	3.347	2.795	8 - 1/2" SQ
6x8-15 HD	3.347	2.795	8 - 1/2" SQ
8x10-15 HD	3.937	2.913	8 - 1/2" SQ
10x12-15 HD	3.937	2.913	8 - 1/2" SQ
4x5-18 HD	3.347	2.795	8 - 1/2" SQ
5x6-18 HD	3.937	2.913	8 - 1/2" SQ
6x8-18 HD	3.937	2.913	8 - 1/2" SQ
8x10-18 HD	3.937	2.913	8 - 1/2" SQ
10x12-18 HD	3.937	2.913	8 - 1/2" SQ

To change rotation, the changes in the assembly procedure are as follows:

1. Place new shaft sleeve o-rings (#331C) onto shaft sleeves (#41A).
2. Wipe over shaft (#41A) with clean light oil. Screw shaft sleeve (#42A) onto shaft (#41A) at the outboard location until the non threaded end of the shaft sleeve (#41A) is properly lined up with the step on the shaft (#41A). See Figure 16.
3. Place impeller key (#24A) into shaft keyway and tap milled-down end under the shaft sleeve (#42A).
4. Check impeller (#11D) for correct rotation (See Figure 11 or 15) and slide onto shaft (#41A) from inboard end.
5. Screw the second shaft sleeve (#42A) onto the shaft (#41A) locking it tight up against the impeller (#11D) and the first shaft sleeve (#42A).

The rest of the assembly procedure remains unchanged from the Right-Hand procedure above.

FIGURE 15 – Stuffing Box Information



Excessive gland pressure will cause damage by cutting off lubrication to the packing and packing will burn and damage the shaft sleeve.

LEFT-HAND ROTATION

Reversing rotation of pumps from right-hand to left-hand puts the suction and discharge of the pump on opposite sides with respect to the inboard end. The reversing of rotation DOES NOT change how and in what direction the impeller rotates with respect to the volute of the casing.

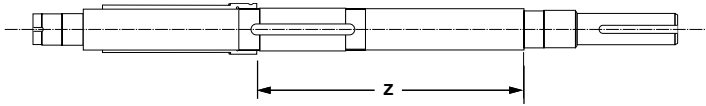

Pump Model	Mechanical Seal	Packed
	A – Inches	
2.5x3-10 HD	8.000	11.312
3x4-10 HD	8.000	11.312
4x6-10 HD	10.188	14.188
5x6-10 HD	10.125	13.438
6x8-10 HD	10.125	13.438
10x10-10 HD	12.625	16.500
5x6-11 HD	8.000	11.312
3x4-12 HD	8.000	11.312
4x5-12 HD	8.000	11.312
5x6-12 HD	10.125	13.438
6x8-12 HD	10.188	14.188
8x10-12 HD	12.625	16.500
10x10-12 HD	12.625	16.500
2x3-15 HD	8.000	11.312
3x4-15 HD	8.000	11.312
4x5-15 HD	10.188	14.188
5x6-15 HD	10.188	14.188
6x8-15 HD	10.188	14.188
8x10-15 HD	13.188	16.688
10x12-15 HD	13.188	16.688
4x5-18 HD	10.188	14.188
5x6-18 HD	13.125	16.688
6x8-18 HD	12.938	16.688
8x10-18 HD	13.188	16.688
10x12-18 HD	15.688	16.688

FIGURE 16 – Left-Hand Shaft Sleeve Dimensions

APPENDIX A

AMERICAN-MARSH HD MAINTENANCE INSTRUCTIONS BEARING HOUSING OIL SEALS (LABYRINTH TYPE) INPRO/SEAL® VBXX BEARING ISOLATORS

INTRODUCTION

American-Marsh Pumps provides pumps fitted with a variety of labyrinth oil seals. While these instructions are written specifically for the Inpro/Seal VBXX labyrinth, they also apply to seals of other manufacturers. Specific installation instructions included with the seal, regardless of manufacturer, should be observed.

The Inpro “VBXX” Bearing Isolator is a labyrinth type seal which isolates the bearings from the environment (uncontaminated), and retains the oil in the bearing housing. The bearing isolator consists of a rotor and a stator. The rotor revolves with the shaft, driven by a close fitted drive ring that rotates with the shaft. The stator is a stationary component that fits into the housing bore with a press fit (nominal 0.002 in (0.05 mm) interference) and with an “O” ring gasket seal. The two pieces are assembled as a single unit, and are axially locked together by an “O” ring. There is no mechanical contact between the rotor and stator when the isolator is running.

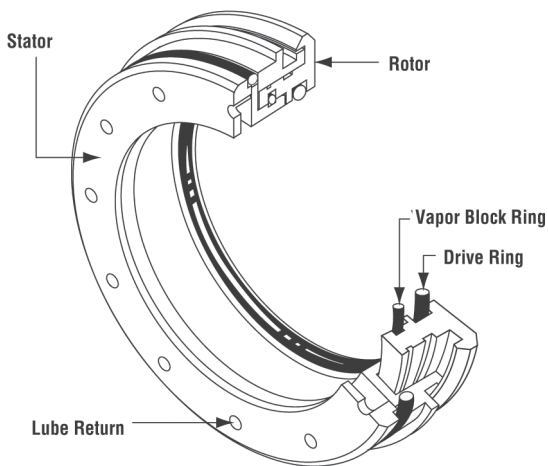

FIGURE 17 – Bearing Isolator

The VBXX is not intended to be separated from the bearing arm unless being replaced.

1. If the VBXX is removed from the housing, for any reason, it must be replaced with a new VBXX to ensure a perfect seal with the housing bore.

2. Repair or replacement of the seals is only necessary when excessive oil leakage is evident. However, if for any other reason, the bearing housing is to be disassembled or the pump shaft removed, it is recommended that the rotor “O” rings (which seal on the shaft) be replaced. Spare or replacement “O” rings may be obtained from “Inpro” distributors.

The “Inpro” VBXX bearing isolator is a one piece assembly. The rotor must not pull out of the stator. If the rotor can be removed, the complete seal assembly must be replaced.

3. If the bearing arm with bronze VBXX seals is washed or cleaned using a caustic type bath, the bronze material may discolor (turn black). If this happens, the complete seal assembly must be replaced. Note: This may occur if the housing is left in a caustic bath over a long period of time (more than 8 hours).

4. To remove the VBXX bearing isolator:

- A. Remove the pump shaft as described in the pump disassembly instructions.

- B. From the inside of the bearing arm (#86N & 86P), place a bar (made from a soft material such as wood or plastic) against the inside face of the seal. Push the seal out by tapping the bar with a soft mallet or an arbor press.

5. To install a new VBXX bearing isolator, in the outboard or inboard bearing arm:

- A. Position the outboard seal in the bore of the bearing arm (#86N & 86P) with the single expulsion port at the 6 o'clock position, (carefully keep aligned with the bore).

- B. The seal stator O.D. press fits into the bore. Use an arbor press. Place a block or bar (large enough to protect the rotor flange) between the arbor press ram and seal face. Press the seal down into the bore stopping at the shoulder on the stator O.D.

The elastomer “O” ring acts as a gasket to ensure damming up of small imperfections in the housing bore. The “O” ring is designed to be compressed to the point of overfilling its groove. The overfilled material is sheared off during assembly. Remove any sheared “O” ring material which may extrude from the bore.

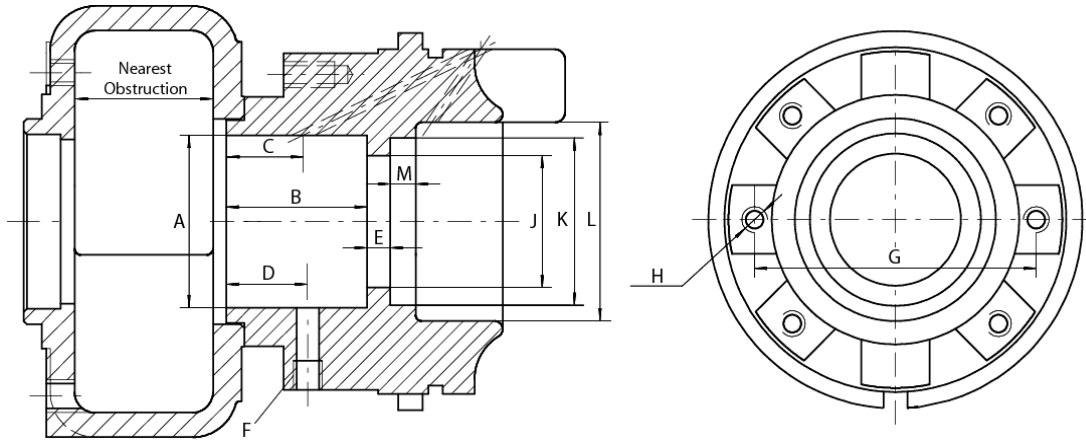

Pump Model	Module	Sleeve Diameter	Packed Orientation							Mechanically Sealed Orientation					
			Nearest Obstruction	A	B	C	D	E	F	G	H	J	K	L	M
2.5x3-10 HD	1	1.750	2.250	2.559	2.362	1.329	1.299	0.276	¼" - 18	4.330	3/8" - 16	1.937	2.500	2.953	0.437
3x4-10 HD	1	1.750	2.250	559	2.362	1.329	1.299	0.276	¼" - 18	4.330	3/8" - 16	1.937	2.500	2.953	0.437
4x6-10 HD	4	2.375	2.625	3.346	2.755	1.496	1.594	0.453	¼" - 18	5.512	½" - 13	2.563	3.250	3.858	0.500
5x6-10 HD	3	1.750	2.250	2.559	2.362	1.329	1.280	0.591	¼" - 18	4.330	3/8" - 16	1.937	2.500	2.953	0.437
6x8-10 HD	3	1.750	2.250	2.559	2.362	1.329	1.280	0.591	¼" - 18	4.330	3/8" - 16	1.937	2.500	2.953	0.437
10x10-10 HD	6	2.375	2.625	3.346	2.795	1.496	1.575	0.846	¼" - 18	5.512	½" - 13	2.563	3.250	3.565	0.500
5x6-11 HD	2	1.750	2.250	2.559	2.362	1.329	1.329	0.276	¼" - 18	4.330	3/8" - 16	1.937	2.500	2.953	0.437
3x4-12 HD	1	1.750	2.250	2.559	2.362	1.329	1.299	0.276	¼" - 18	4.330	3/8" - 16	1.937	2.500	2.953	0.437
4x5-12 HD	2	1.750	2.250	2.559	2.362	1.329	1.329	0.276	¼" - 18	4.330	3/8" - 16	1.937	2.500	2.953	0.437
5x6-12 HD	3	1.750	2.250	2.559	2.362	1.329	1.280	0.591	¼" - 18	4.330	3/8" - 16	1.937	2.500	2.953	0.437
6x8-12 HD	5	2.375	2.625	3.346	2.795	1.575	1.574	0.414	¼" - 18	5.512	½" - 13	2.563	3.250	3.858	0.500
8x10-12 HD	6	2.375	2.625	3.346	2.795	1.496	1.575	0.846	¼" - 18	5.512	½" - 13	2.563	3.250	3.565	0.500
10x10-12 HD	6	2.375	2.625	3.346	2.795	1.496	1.575	0.846	¼" - 18	5.512	½" - 13	2.563	3.250	3.565	0.500
2x3-15 HD	2	1.750	2.250	2.559	2.362	1.329	1.329	0.276	¼" - 18	4.330	3/8" - 16	1.937	2.500	2.953	0.437
3x4-15 HD	2	1.750	2.250	2.559	2.362	1.329	1.329	0.276	¼" - 18	4.330	3/8" - 16	1.937	2.500	2.953	0.437
4x5-15 HD	4	2.375	2.625	3.346	2.755	1.496	1.594	0.453	¼" - 18	5.512	½" - 13	2.563	3.250	3.858	0.500
5x6-15 HD	5	2.375	2.625	3.346	2.795	1.575	1.574	0.414	¼" - 18	5.512	½" - 13	2.563	3.250	3.858	0.500
6x8-15 HD	5	2.375	2.625	3.346	2.795	1.575	1.574	0.414	¼" - 18	5.512	½" - 13	2.563	3.250	3.858	0.500
4x5-18 HD	5	2.375	2.750	3.346	2.795	1.575	1.574	0.414	¼" - 18	5.512	½" - 13	2.563	3.250	3.858	0.500

Figure 18A – Packing/Seal Chamber Details

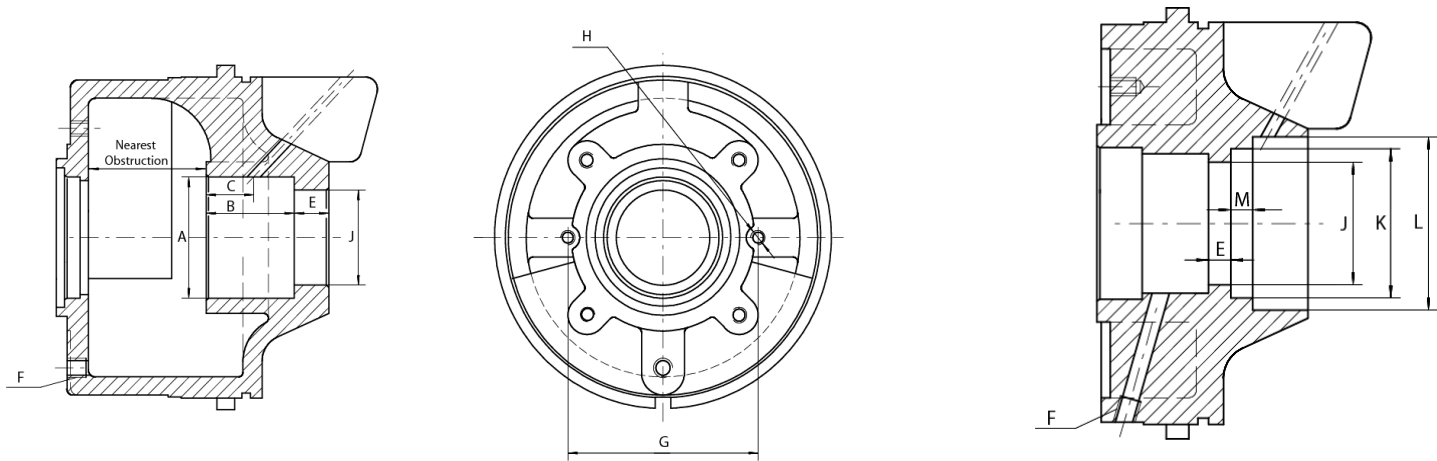

Pump Model	Module	Sleeve Diameter	Packed Orientation							Mechanically Sealed Orientation					
			Nearest Obstruction	A	B	C	D	E	F	G	H	J	K	L	M
8x10-15 HD	7	3.000	3.750	3.937	2.913	1.574	N/A	1.142	3/8" -18	6.299	1/2" - 13	3.187	3.875	4.500	0.562
10x12-15 HD	7	3.000	3.750	3.937	2.913	1.574	N/A	1.142	3/8" -18	6.299	1/2" - 13	3.187	3.875	4.500	0.562
5x8-18 HD	7	3.000	3.750	3.937	2.913	1.574	N/A	1.142	3/8" -18	6.299	1/2" - 13	3.187	3.875	4.500	0.562
6x8-18 HD	7	3.000	3.750	3.937	2.913	1.574	N/A	1.142	3/8" -18	6.299	1/2" - 13	3.187	3.875	4.500	0.562
8x10-18 HD	7	3.000	3.750	3.937	2.913	1.574	N/A	1.142	3/8" -18	6.299	1/2" - 13	3.187	3.875	4.500	0.562

Figure 18B – Packing/Seal Chamber Details

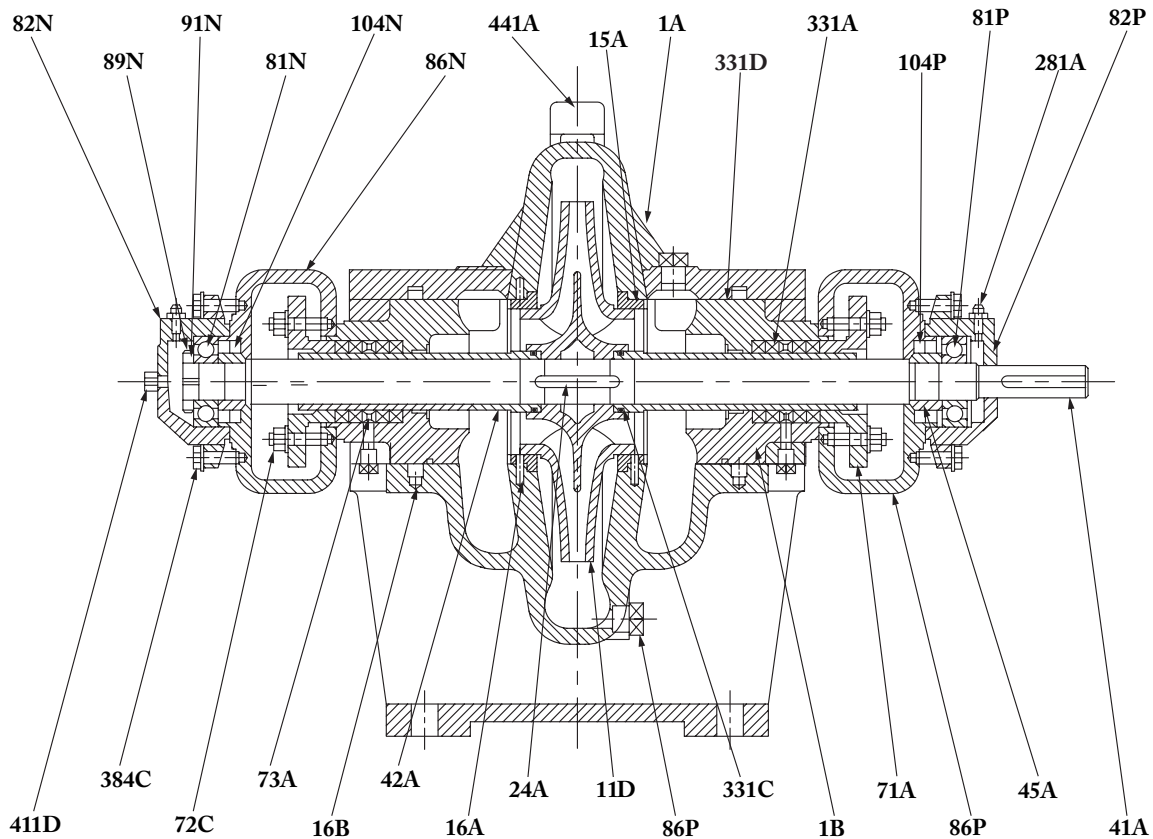

HD Packed Sectional Drawing

Item Number	Item Description	Number Required	Item Number	Item Description	Number Required
1A	Casing, Complete	1	86N	Bearing Arm, Outboard	1
1B	Stuffing Box	2	86P	Bearing Arm, Inboard	1
11D	Impeller	1	89N	Locknut, Outboard	1
15A	Case Wear Ring	2	91N*	Lockwasher, Outboard	1
16A	Dowel Pin	2	104N	Lip Seal, Outboard	1
16B	Dowel Pin	2	104P	Lip Seal, Inboard	1
24A	Impeller Key	1	281A	Zerk Fitting	2
41A	Shaft	1	331A	Packing	1 Set
42A	Shaft Sleeve	2	331B	Mechanical Seal	2
45A	Bearing Adapter	2	331C	Shaft Sleeve O-Ring	2
71A	Gland Assembly, Complete	2	331D	Stuffing Box O-Ring	2
72C	Hinge Bolt	4	353A*	Case Gasket	1
73A	Lantern Ring	2	381B*	Casing Capscrew	Varies
81N	Outboard Bearing, Thrust	1	384B	Bearing Housing Capscrews	8
81P	Inboard Bearing, Radial	1	411A	Plug, Vent	1
82N	Bearing Housing, Outboard	1	411B	Plug, Drain	1
82P	Bearing Housing, Inboard	1	411D	Plug, Bearing Housing	1

* Not shown in sectional.

Recommended spare parts are in BOLD.

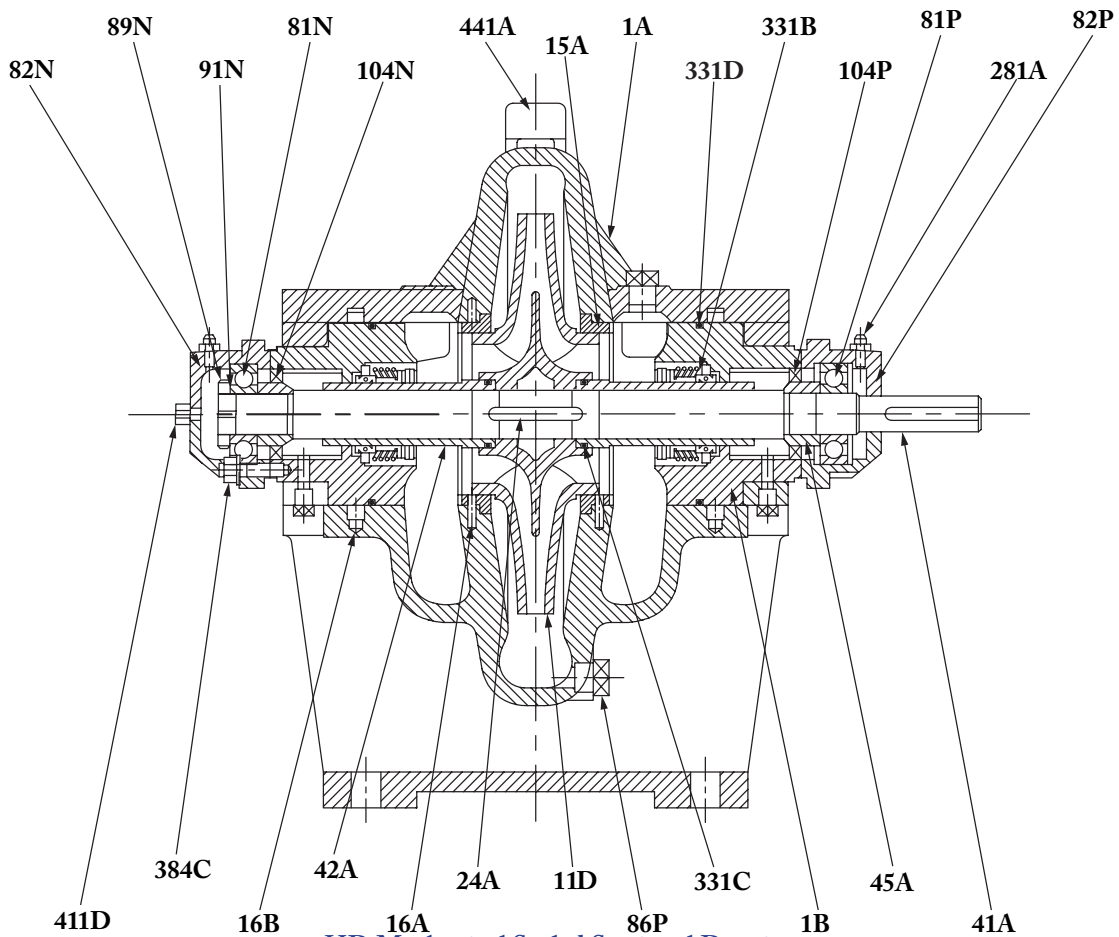

HD Mechanical Sealed Sectional Drawing

Item Number	Item Description	Number Required	Item Number	Item Description	Number Required
1A	Casing, Complete	1	86N	Bearing Arm, Outboard	1
1B	Stuffing Box	2	86P	Bearing Arm, Inboard	1
11D	Impeller	1	89N	Locknut, Outboard	1
15A	Case Wear Ring	2	91N*	Lockwasher, Outboard	1
16A	Dowel Pin	2	104N	Lip Seal, Outboard	1
16B	Dowel Pin	2	104P	Lip Seal, Inboard	1
24A	Impeller Key	1	281A	Zerk Fitting	2
41A	Shaft	1	331A	Packing	1 Set
42A	Shaft Sleeve	2	331B	Mechanical Seal	2
45A	Bearing Adapter	2	331C	Shaft Sleeve O-Ring	2
71A	Gland Assembly, Complete	2	331D	Stuffing Box O-Ring	2
72C	Hinge Bolt	4	353A*	Case Gasket	1
73A	Lantern Ring	2	381B*	Casing Capscrew	Varies
81N	Outboard Bearing, Thrust	1	384B	Bearing Housing Capscrews	8
81P	Inboard Bearing, Radial	1	411A	Plug, Vent	1
82N	Bearing Housing, Outboard	1	411B	Plug, Drain	1
82P	Bearing Housing, Inboard	1	411D	Plug, Bearing Housing	1

* Not shown in sectional.
Recommended spare parts are in BOLD.