

Durability By Design Since 1873



2023 Product Brochure

340 Series HD

Double Suction Split Case Pumps

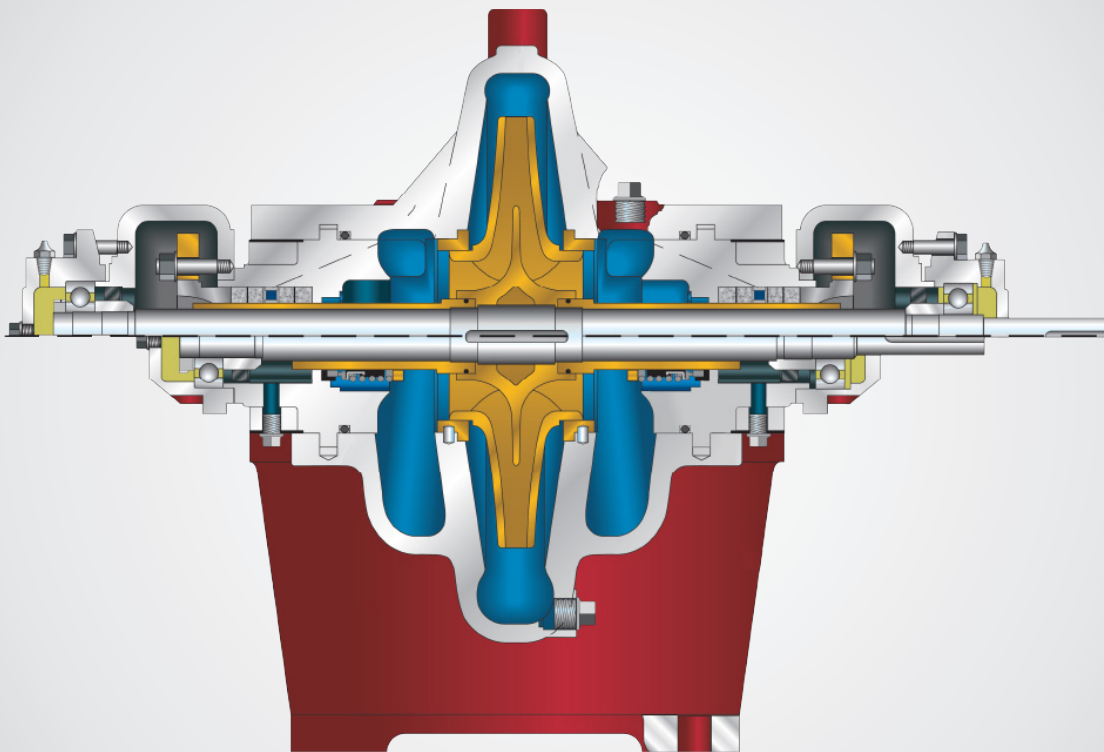

340 Series HD

Double Suction Split Case Pumps

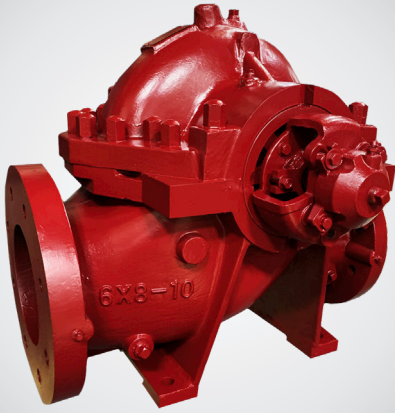

Applications

- Circulation
- Booster
- HVAC
- Transfer
- Cooling Tower
- Agriculture & Irrigation

Max Head: 550 feet

Max. Flow: 16,000 GPM

Features & Benefits

- Double suction impellers
- Heavy-duty construction
- Replaceable bearings without full disassembly
- Case wear rings
- Internal plan 1 flush

Technical Data

- Temperature up to 180°F
- Base mounted, flex-coupled
- Discharge sizes: 2.5"–14"

Materials of Construction

- Cast Iron
- Bronze fitted
- Packed or mechanical seal
- Optional metallurgies available

