

Durability By Design Since 1873



*2021 Product Brochure*

## **340 Series HD**

Double Suction Split Case Pumps

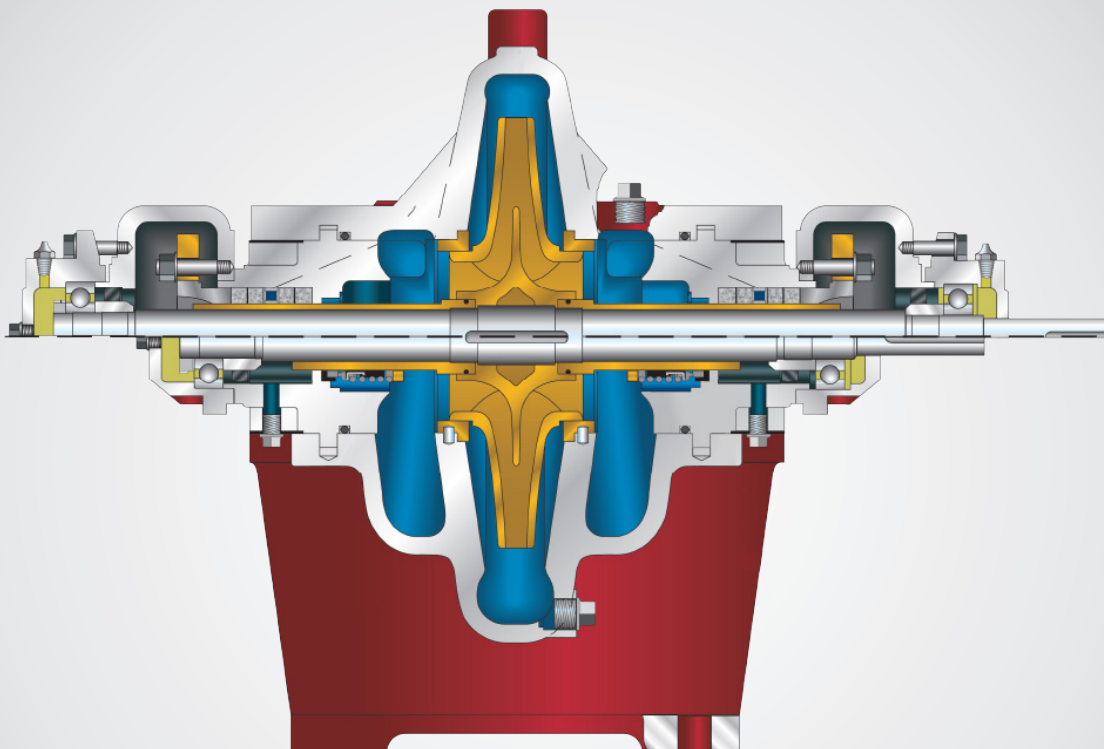

## 340 Series HD

### Double Suction Split Case Pumps

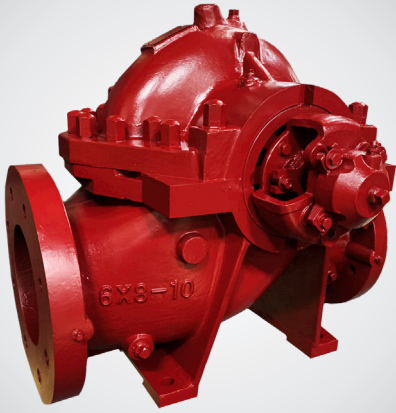

#### Applications

- Circulation
- Booster
- HVAC
- Transfer
- Cooling tower
- Agriculture & Irrigation

**Max Head:** 550 feet

**Max. Flow:** 16,000 GPM

#### Features & Benefits

- Double suction impellers
- Heavy-duty construction
- Replaceable bearings without full disassembly
- Replaceable case wear rings
- Internal plan 1 flush

#### Technical Data

- Temperature up to 180°F
- Base mounted, flex-coupled
- Discharge sizes: 2.5"–14"

#### Materials of Construction

- Cast iron
- Bronze fitted
- Packed or mechanical seal
- Optional metallurgies available

