

Wilo-WiBooster

		Project:					
		Engineer:					
		Contractor:					
		Submitted By:			Date:		
		Approved By:			Date:		
Tag #	Model #	Flow	Head	HP/Pump	Cycle	Phase	Voltage
	WiBooster 3/327/A1/TEFC			20	60Hz		

Article Number: 3311247

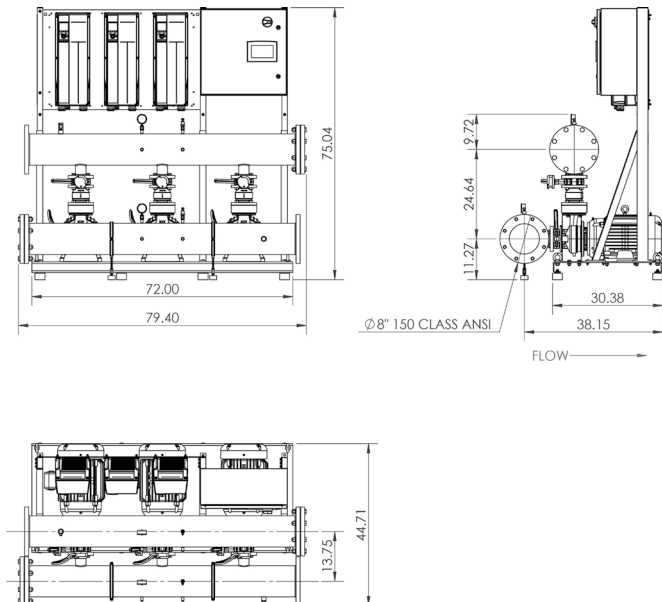
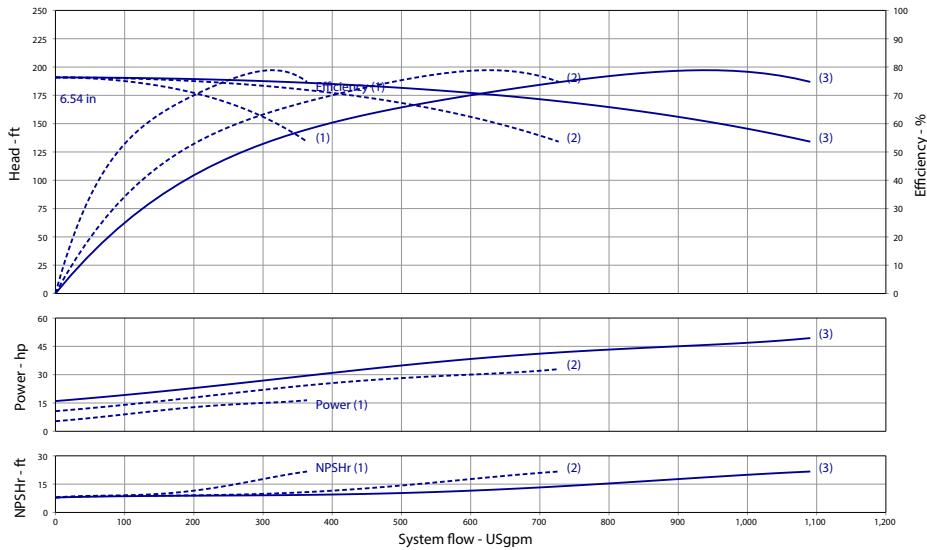

Product Info

Brand	Wilo
Product Description	WiBooster 3/327/A1/315/TEFC

Construction Materials

Pump Volute	304 Stainless Steel
Impeller	304 Stainless Steel
Shaft	304 Stainless Steel
Elastomers	EPDM
Isolation Valves	Butterfly, SS Stem/Disc, EPDM Seal
Manifolds	304 Stainless Steel, ANSI-Flanged
Check Valves	Stainless Steel, Non-Slam, Plunger Type with EPDM Seal
Mechanical Seal	Type 21
Pressure Transducers	316 Stainless Steel
Pressure Gauges	304/316 Stainless Steel
System Base	Plated Steel
Vibration Isolators	Neoprene, Height-Adjustable

Motor Data

Motor Power Supply	3-208-230V
Enclosure	TEFC
Efficiency	NEMA Premium
Horsepower/Pump	20
Enclosure Material	Rolled Steel/Cast Iron
Motor Protection Class	IP54
Insulation Class	F

Hydraulic Data

Max Operating Pressure	150 PSI
Max Inlet Pressure	75 PSI
Min. Fluid Temp.	40°F
Max Fluid Temp.	140°F
Min. Ambient Temp	32°F
Max. Ambient Temp	104°F

Panel Info

Power Supply	3-208-230
Enclosure	NEMA 12 (3R Available on Request)
Standard	Meets UL 508A
VFD's	Danfoss FC-101/FC-202

PLC Info

User Interface	7" Color Touchscreen
Display Resolution	800 x 480 Pixels
Supply Voltage	24VDC
Max Current	320mA @24V
Analog Inputs/Outputs	9/2
Digital Inputs/Outputs	18/17
Communications	ModBUS Standard (BacNET, LONWorks Optional)
Ethernet Port	RJ45 (10/100Mbps)
Additional Ports	USB 2.0, Micro-SD



Triplex Phase and Voltage	Full Flow Connection (in)			Half Flow Connection (in)		
	3~208-230V	3~460V	3~575V	3~575V	3~460	3~575
Panel Dimensions (HxWxD)	24x24x8	30x39x12	24x24x8	24x24x8	4	4
Full Load Amps (Per Pump)	47	23.5	19	47	23.5	19
Panel Weight (lbs)	100	164.5	92	100	164.5	92
External VFD Weight (ea - lbs)	60	X	50	60	X	50
Pump Weight (ea - lbs)	260	260	260	260	260	260
System Weight (lbs)	1990	1870	2095	1860	1740	1960

Wilo-WiBooster

		Project:					
		Engineer:					
		Contractor:					
		Submitted By:			Date:		
		Approved By:			Date:		
Tag #	Model #	Flow	Head	HP/Pump	Cycle	Phase	Voltage
	WiBooster 3/327/A1/TEFC			20	60Hz		

Article Number: 3311265

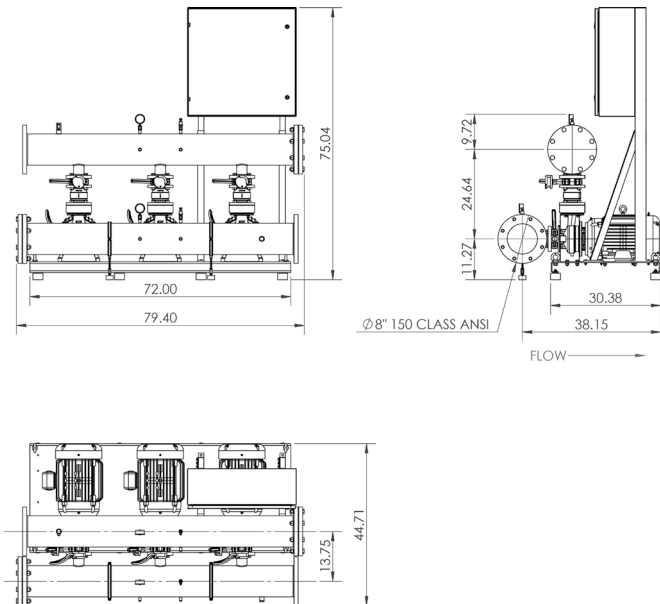
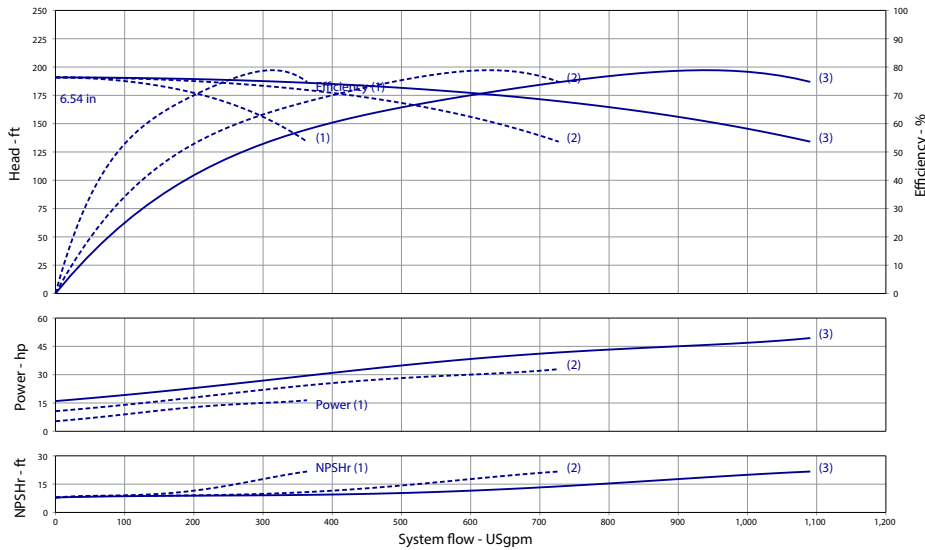

Product Info

Brand	Wilo
Product Description	WiBooster 3/327/A1/315/TEFC

Construction Materials

Pump Volute	304 Stainless Steel
Impeller	304 Stainless Steel
Shaft	304 Stainless Steel
Elastomers	EPDM
Isolation Valves	Butterfly, SS Stem/Disc, EPDM Seal
Manifolds	304 Stainless Steel, ANSI-Flanged
Check Valves	Stainless Steel, Non-Slam, Plunger Type with EPDM Seal
Mechanical Seal	Type 21
Pressure Transducers	316 Stainless Steel
Pressure Gauges	304/316 Stainless Steel
System Base	Plated Steel
Vibration Isolators	Neoprene, Height-Adjustable

Motor Data

Motor Power Supply	3-460V
Enclosure	TEFC
Efficiency	NEMA Premium
Horsepower/Pump	20
Enclosure Material	Rolled Steel/Cast Iron
Motor Protection Class	IP54
Insulation Class	F

Hydraulic Data

Max Operating Pressure	150 PSI
Max Inlet Pressure	75 PSI
Min. Fluid Temp.	40°F
Max Fluid Temp.	140°F
Min. Ambient Temp	32°F
Max. Ambient Temp	104°F

Panel Info

Power Supply	3-460
Enclosure	NEMA 12 (3R Available on Request)
Standard	Meets UL 508A
VFD's	Danfoss FC-101/FC-202

PLC Info

User Interface	7" Color Touchscreen
Display Resolution	800 x 480 Pixels
Supply Voltage	24VDC
Max Current	320mA @24V
Analog Inputs/Outputs	9/2
Digital Inputs/Outputs	18/17
Communications	ModBUS Standard (BacNET, LONWorks Optional)
Ethernet Port	RJ45 (10/100Mbps)
Additional Ports	USB 2.0, Micro-SD



Triplex Phase and Voltage	Full Flow Connection (in)			Half Flow Connection (in)		
	3~208-230V	3~460V	3~575V	3~575V	3~460	3~575
Panel Dimensions (HxWxD)	24x24x8	30x39x12	24x24x8	24x24x8	4	4
Full Load Amps (Per Pump)	47	23.5	19	47	23.5	19
Panel Weight (lbs)	100	164.5	92	100	164.5	92
External VFD Weight (ea - lbs)	60	X	50	60	X	50
Pump Weight (ea - lbs)	260	260	260	260	260	260
System Weight (lbs)	1990	1870	2095	1860	1740	1960

Wilo-WiBooster

		Project:					
		Engineer:					
		Contractor:					
		Submitted By:			Date:		
		Approved By:			Date:		
Tag #	Model #	Flow	Head	HP/Pump	Cycle	Phase	Voltage
	WiBooster 3/327/A1/TEFC			20	60Hz		

Article Number: 3311283

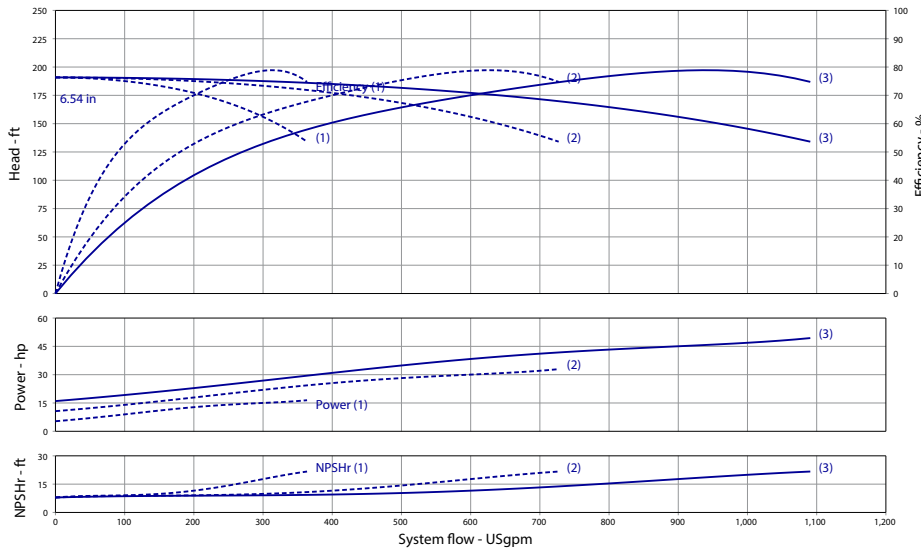

Product Info

Brand	Wilo
Product Description	WiBooster 3/327/A1/315/TEFC

Construction Materials

Pump Volute	304 Stainless Steel
Impeller	304 Stainless Steel
Shaft	304 Stainless Steel
Elastomers	EPDM
Isolation Valves	Butterfly, SS Stem/Disc, EPDM Seal
Manifolds	304 Stainless Steel, ANSI-Flanged
Check Valves	Stainless Steel, Non-Slam, Plunger Type with EPDM Seal
Mechanical Seal	Type 21
Pressure Transducers	316 Stainless Steel
Pressure Gauges	304/316 Stainless Steel
System Base	Plated Steel
Vibration Isolators	Neoprene, Height-Adjustable

Motor Data

Motor Power Supply	3-575V
Enclosure	TEFC
Efficiency	NEMA Premium
Horsepower/Pump	20
Enclosure Material	Rolled Steel/Cast Iron
Motor Protection Class	IP54
Insulation Class	F

Hydraulic Data

Max Operating Pressure	150 PSI
Max Inlet Pressure	75 PSI
Min. Fluid Temp.	40°F
Max Fluid Temp.	140°F
Min. Ambient Temp	32°F
Max. Ambient Temp	104°F

Panel Info

Power Supply	3-575
Enclosure	NEMA 12 (3R Available on Request)
Standard	Meets UL 508A
VFD's	Danfoss FC-101/FC-202

PLC Info

User Interface	7" Color Touchscreen
Display Resolution	800 x 480 Pixels
Supply Voltage	24VDC
Max Current	320mA @24V
Analog Inputs/Outputs	9/2
Digital Inputs/Outputs	18/17
Communications	ModBUS Standard (BacNET, LONWorks Optional)
Ethernet Port	RJ45 (10/100Mbps)
Additional Ports	USB 2.0, Micro-SD

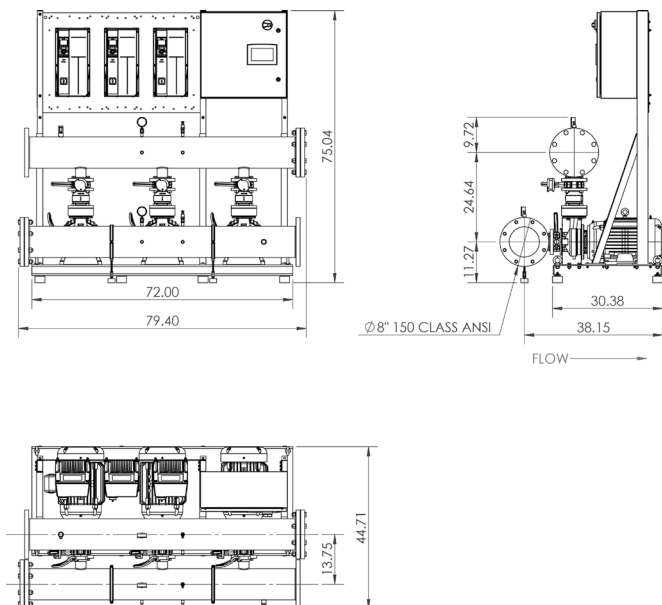

Triplex Phase and Voltage	Full Flow Connection (in)			Half Flow Connection (in)		
	3~208-230V	3~460V	3~575V	3~575V	3~460	3~575
Panel Dimensions (HxWxD)	24x24x8	30x39x12	24x24x8	24x24x8	4	4
Full Load Amps (Per Pump)	47	23.5	19	47	23.5	19
Panel Weight (lbs)	100	164.5	92	100	164.5	92
External VFD Weight (ea - lbs)	60	X	50	60	X	50
Pump Weight (ea - lbs)	260	260	260	260	260	260
System Weight (lbs)	1990	1870	2095	1860	1740	1960



Wilo-WiBooster

		Project:					
		Engineer:					
		Contractor:					
		Submitted By:			Date:		
		Approved By:			Date:		
Tag #	Model #	Flow	Head	HP/Pump	Cycle	Phase	Voltage
	WiBooster 3/327/A2/TEFC			20	60Hz		

Article Number: 3313244

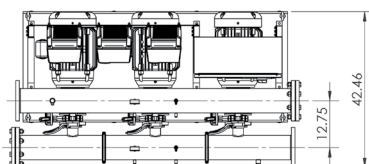
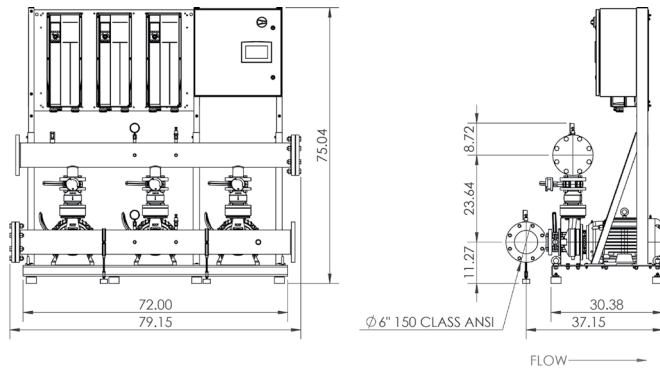
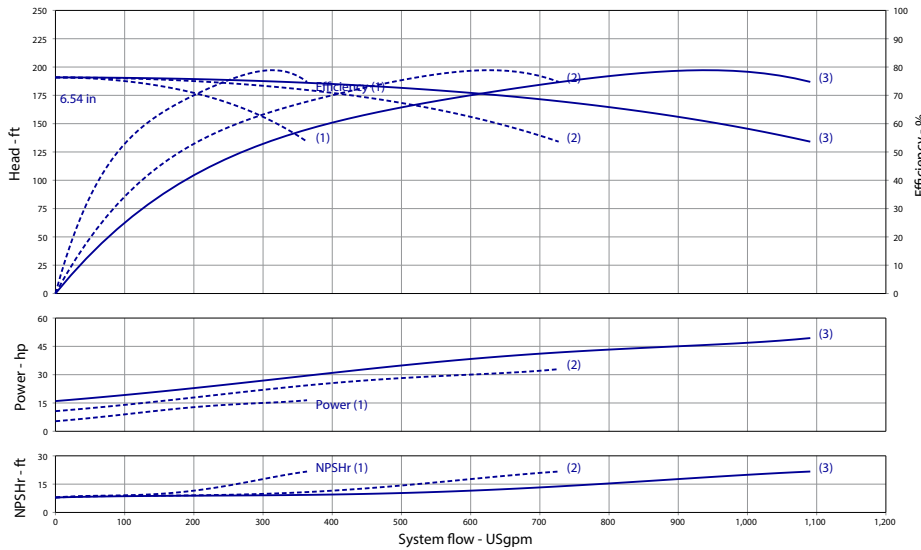

Product Info

Brand	Wilo
Product Description	WiBooster 3/327/A2/315/TEFC

Construction Materials

Pump Volute	304 Stainless Steel
Impeller	304 Stainless Steel
Shaft	304 Stainless Steel
Elastomers	EPDM
Isolation Valves	Butterfly, SS Stem/Disc, EPDM Seal
Manifolds	304 Stainless Steel, ANSI-Flanged
Check Valves	Stainless Steel, Non-Slam, Plunger Type with EPDM Seal
Mechanical Seal	Type 21
Pressure Transducers	316 Stainless Steel
Pressure Gauges	304/316 Stainless Steel
System Base	Plated Steel
Vibration Isolators	Neoprene, Height-Adjustable

Motor Data

Motor Power Supply	3~208-230V
Enclosure	TEFC
Efficiency	NEMA Premium
Horsepower/Pump	20
Enclosure Material	Rolled Steel/Cast Iron
Motor Protection Class	IP54
Insulation Class	F

Hydraulic Data

Max Operating Pressure	150 PSI
Max Inlet Pressure	75 PSI
Min. Fluid Temp.	40°F
Max Fluid Temp.	140°F
Min. Ambient Temp	32°F
Max. Ambient Temp	104°F

Panel Info

Power Supply	3~208-230
Enclosure	NEMA 12 (3R Available on Request)
Standard	Meets UL 508A
VFD's	Danfoss FC-101/FC-202

PLC Info

User Interface	7" Color Touchscreen
Display Resolution	800 x 480 Pixels
Supply Voltage	24VDC
Max Current	320mA @24V
Analog Inputs/Outputs	9/2
Digital Inputs/Outputs	18/17
Communications	ModBUS Standard (BacNET, LONWorks Optional)
Ethernet Port	RJ45 (10/100Mbps)
Additional Ports	USB 2.0, Micro-SD



Triplex Phase and Voltage	Full Flow Connection (in)			Half Flow Connection (in)		
	3~208-230V	3~460V	3~575V	3~575V	3~460	3~575
Panel Dimensions (HxWxD)	24x24x8	30x39x12	24x24x8	24x24x8	4	4
Full Load Amps (Per Pump)	47	23.5	19	47	23.5	19
Panel Weight (lbs)	100	164.5	92	100	164.5	92
External VFD Weight (ea - lbs)	60	X	50	60	X	50
Pump Weight (ea - lbs)	260	260	260	260	260	260
System Weight (lbs)	1990	1870	2095	1860	1740	1960

Wilo-WiBooster

		Project:					
		Engineer:					
		Contractor:					
		Submitted By:			Date:		
		Approved By:			Date:		
Tag #	Model #	Flow	Head	HP/Pump	Cycle	Phase	Voltage
	WiBooster 3/327/A2/TEFC			20	60Hz		

Article Number: 3313262

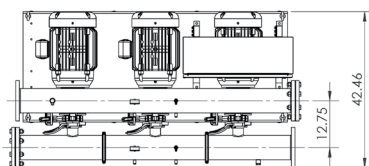
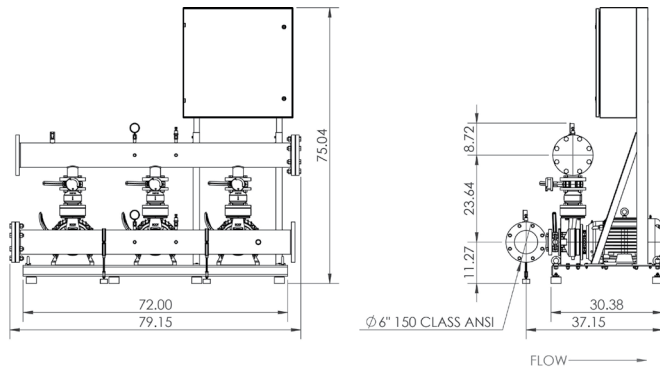
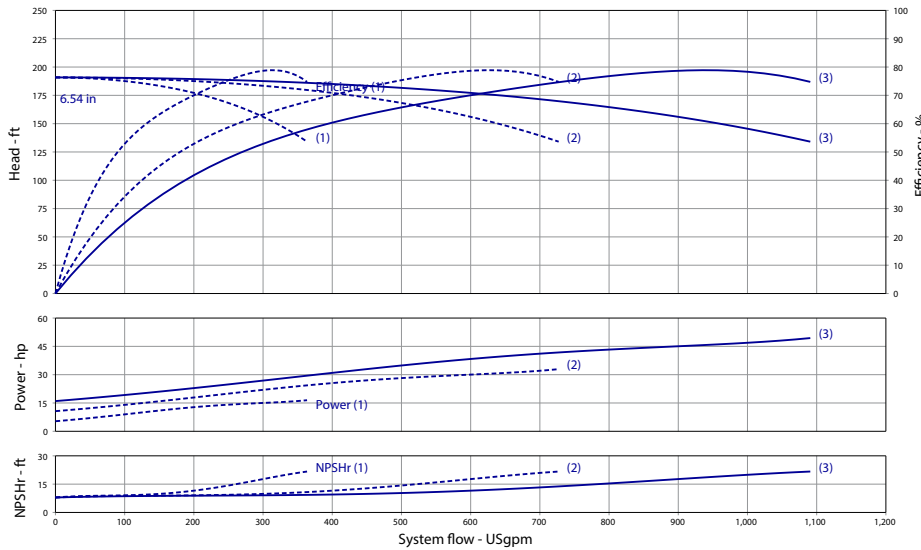

Product Info

Brand	Wilo
Product Description	WiBooster 3/327/A2/315/TEFC

Construction Materials

Pump Volute	304 Stainless Steel
Impeller	304 Stainless Steel
Shaft	304 Stainless Steel
Elastomers	EPDM
Isolation Valves	Butterfly, SS Stem/Disc, EPDM Seal
Manifolds	304 Stainless Steel, ANSI-Flanged
Check Valves	Stainless Steel, Non-Slam, Plunger Type with EPDM Seal
Mechanical Seal	Type 21
Pressure Transducers	316 Stainless Steel
Pressure Gauges	304/316 Stainless Steel
System Base	Plated Steel
Vibration Isolators	Neoprene, Height-Adjustable

Motor Data

Motor Power Supply	3-460V
Enclosure	TEFC
Efficiency	NEMA Premium
Horsepower/Pump	20
Enclosure Material	Rolled Steel/Cast Iron
Motor Protection Class	IP54
Insulation Class	F

Hydraulic Data

Max Operating Pressure	150 PSI
Max Inlet Pressure	75 PSI
Min. Fluid Temp.	40°F
Max Fluid Temp.	140°F
Min. Ambient Temp	32°F
Max. Ambient Temp	104°F

Panel Info

Power Supply	3-460
Enclosure	NEMA 12 (3R Available on Request)
Standard	Meets UL 508A
VFD's	Danfoss FC-101/FC-202

PLC Info

User Interface	7" Color Touchscreen
Display Resolution	800 x 480 Pixels
Supply Voltage	24VDC
Max Current	320mA @24V
Analog Inputs/Outputs	9/2
Digital Inputs/Outputs	18/17
Communications	ModBUS Standard (BacNET, LONWorks Optional)
Ethernet Port	RJ45 (10/100Mbps)
Additional Ports	USB 2.0, Micro-SD



Triplex	Full Flow Connection (in)			Half Flow Connection (in)		
	3~208-230V	3~460V	3~575V	3~575V	3~460	3~575
Panel Dimensions (HxWxD)	24x24x8	30x39x12	24x24x8	24x24x8	4	4
Full Load Amps (Per Pump)	47	23.5	19	47	23.5	19
Panel Weight (lbs)	100	164.5	92	100	164.5	92
External VFD Weight (ea - lbs)	60	X	50	60	X	50
Pump Weight (ea - lbs)	260	260	260	260	260	260
System Weight (lbs)	1990	1870	2095	1860	1740	1960

Wilo-WiBooster

		Project:					
		Engineer:					
		Contractor:					
		Submitted By:			Date:		
		Approved By:			Date:		
Tag #	Model #	Flow	Head	HP/Pump	Cycle	Phase	Voltage
	WiBooster 3/327/A2/TEFC			20	60Hz		

Article Number: 3313279

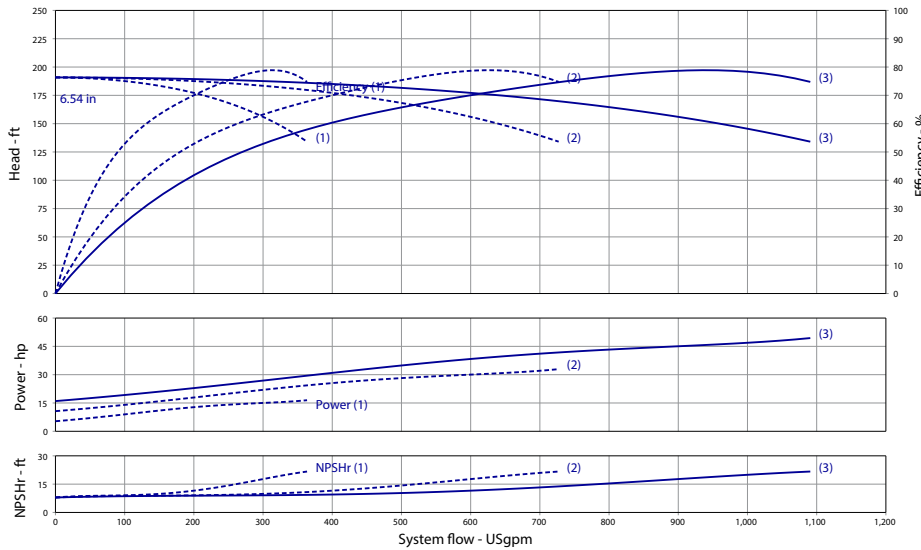

Product Info

Brand	Wilo
Product Description	WiBooster 3/327/A2/315/TEFC

Construction Materials

Pump Volute	304 Stainless Steel
Impeller	304 Stainless Steel
Shaft	304 Stainless Steel
Elastomers	EPDM
Isolation Valves	Butterfly, SS Stem/Disc, EPDM Seal
Manifolds	304 Stainless Steel, ANSI-Flanged
Check Valves	Stainless Steel, Non-Slam, Plunger Type with EPDM Seal
Mechanical Seal	Type 21
Pressure Transducers	316 Stainless Steel
Pressure Gauges	304/316 Stainless Steel
System Base	Plated Steel
Vibration Isolators	Neoprene, Height-Adjustable

Motor Data

Motor Power Supply	3-575V
Enclosure	TEFC
Efficiency	NEMA Premium
Horsepower/Pump	20
Enclosure Material	Rolled Steel/Cast Iron
Motor Protection Class	IP54
Insulation Class	F

Hydraulic Data

Max Operating Pressure	150 PSI
Max Inlet Pressure	75 PSI
Min. Fluid Temp.	40°F
Max Fluid Temp.	140°F
Min. Ambient Temp	32°F
Max. Ambient Temp	104°F

Panel Info

Power Supply	3-575
Enclosure	NEMA 12 (3R Available on Request)
Standard	Meets UL 508A
VFD's	Danfoss FC-101/FC-202

PLC Info

User Interface	7" Color Touchscreen
Display Resolution	800 x 480 Pixels
Supply Voltage	24VDC
Max Current	320mA @24V
Analog Inputs/Outputs	9/2
Digital Inputs/Outputs	18/17
Communications	ModBUS Standard (BacNET, LONWorks Optional)
Ethernet Port	RJ45 (10/100Mbps)
Additional Ports	USB 2.0, Micro-SD

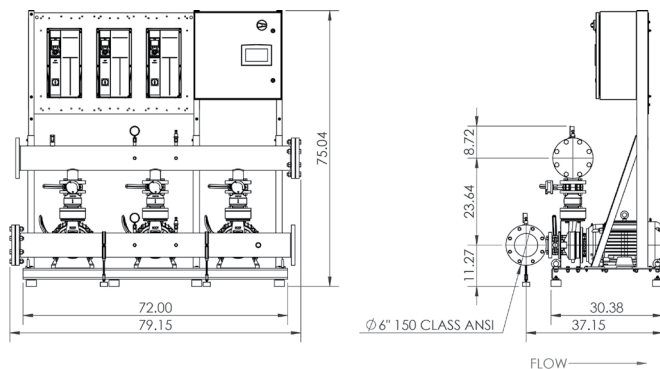

Triplex Phase and Voltage	Full Flow Connection (in)			Half Flow Connection (in)		
	3~208-230V	3~460V	3~575V	3~575V	3~460	3~575
Panel Dimensions (HxWxD)	24x24x8	30x39x12	24x24x8	24x24x8	4	4
Full Load Amps (Per Pump)	47	23.5	19	47	23.5	19
Panel Weight (lbs)	100	164.5	92	100	164.5	92
External VFD Weight (ea - lbs)	60	X	50	60	X	50
Pump Weight (ea - lbs)	260	260	260	260	260	260
System Weight (lbs)	1990	1870	2095	1860	1740	1960

