

Wilo-WiBooster

		Project:					
		Engineer:					
		Contractor:					
		Submitted By:			Date:		
		Approved By:			Date:		
Tag #	Model #	Flow	Head	HP/Pump	Cycle	Phase	Voltage
	WiBooster 2/324/B			7.5	60Hz		

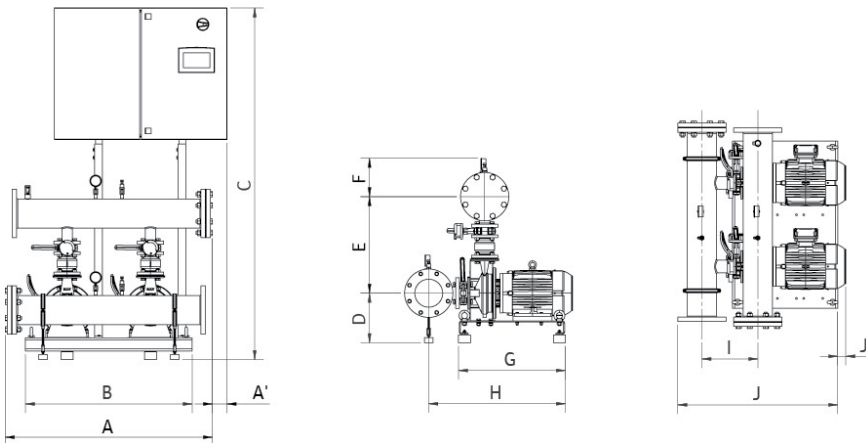
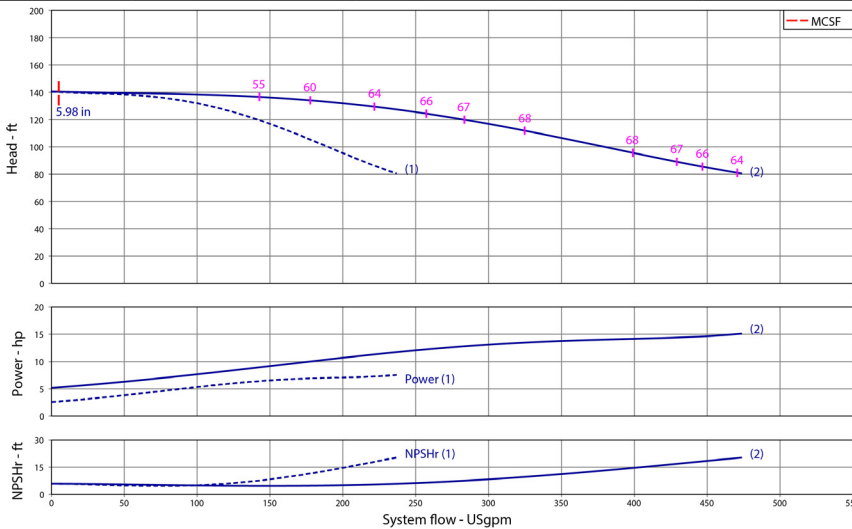

Product Info

Brand	Wilo
Product Description	WiBooster 2/324/B

Construction Materials

Pump Volute	304 Stainless Steel
Impeller	304 Stainless Steel
Shaft	304 Stainless Steel
Elastomers	EPDM
Isolation Valves	Butterfly, SS Stem/Disc, EPDM Seal
Manifolds	304 Stainless Steel, ANSI-Flanged
Check Valves	Stainless Steel, Non-Slam, Plunger Type with EPDM Seal
Mechanical Seal	Type 21
Pressure Transducers	316 Stainless Steel
Pressure Gauges	304/316 Stainless Steel
System Base	Plated Steel
Vibration Isolators	Neoprene, Height-Adjustable

Motor Data

Motor Power Supply	3~208-230/460/575V
Enclosure	ODP/TEFC
Efficiency	NEMA Premium
Horsepower/Pump	7.5
Enclosure Material	Rolled Steel/Cast Iron
Motor Protection Class	IP54
Insulation Class	F

Hydraulic Data

Max Operating Pressure	150 PSI
Max Inlet Pressure	75 PSI
Min. Fluid Temp.	40°F
Max Fluid Temp.	140°F
Min. Ambient Temp	32°F
Max. Ambient Temp	104°F

Panel Info

Power Supply	1~230, 3~208-230/460/575
Enclosure	NEMA 12 (3R Available on Request)
Standard	Meets UL 508A
VFD's	Danfoss FC-51 /FC-101

PLC Info

User Interface	7" Color Touchscreen
Display Resolution	800 x 480 Pixels
Supply Voltage	24VDC
Max Current	320mA @24V
Analog Inputs/Outputs	9/2
Digital Inputs/Outputs	18/17
Communications	ModBUS Standard (BacNET, LONWorks Optional)
Ethernet Port	RJ45 (10/100Mbps)
Additional Ports	USB 2.0, Micro-SD

Dimensions	Full Flow Connection (in)				Half Flow Connection (in)			
	1-3-230	3-208-230	3-460	3-575	1-3-230	3-208-230	3-460	3-575
System Connection (150#)	6	6	6	6	4	4	4	4
A	47.2	47.2	47.2	47.2	46.9	46.9	46.9	46.9
A ₁	3.3	x	x	x	3.5	x	x	x
B	38	38	38	38	38	38	38	38
C	75	75	75	75	75	75	75	75
D	10.2	10.2	10.2	10.2	10.2	10.2	10.2	10.2
E	22.2	22.2	22.2	22.2	20.2	20.2	20.2	20.2
F	8.7	8.7	8.7	10	7.7	7.7	7.7	9
G	24.4	24.4	24.4	24.4	24.4	24.4	24.4	24.4
H	31.1	31.1	31.1	31.1	29.1	29.1	29.1	29.1
I	12	12	12	12	10	10	10	10
J	36.4	36.4	36.4	36.4	33.4	33.4	33.4	33.4
J ₁	x	x	x	x	x	x	x	x
Panel Dimensions (HxWxD)	30x39x12	30X24X10	30X24X10	30X24X10	30x39x12	30X24X10	30X24X10	30X24X10
Full Load Amps (per pump)	18.7-17.0	18.7-17.0	8.5	6.8	18.7-17.0	18.7-17.0	8.5	6.8
Panel Weight (lbs)	125.7	125.7	105.3	130	125.7	125.7	105.3	130
Pump Weight (ea - lbs)	132	132	132	132	132	132	132	132
System Weight (lbs)	870	870	830	875	800	800	760	805

Approval Stamp