

Wilo-WiBooster

		Project:					
		Engineer:					
		Contractor:					
		Submitted By:			Date:		
		Approved By:			Date:		
Tag #	Model #	Flow	Head	HP/Pump	Cycle	Phase	Voltage
	WiBooster 4/327/A1/TEFC			20	60Hz		

Article Number: 3311250

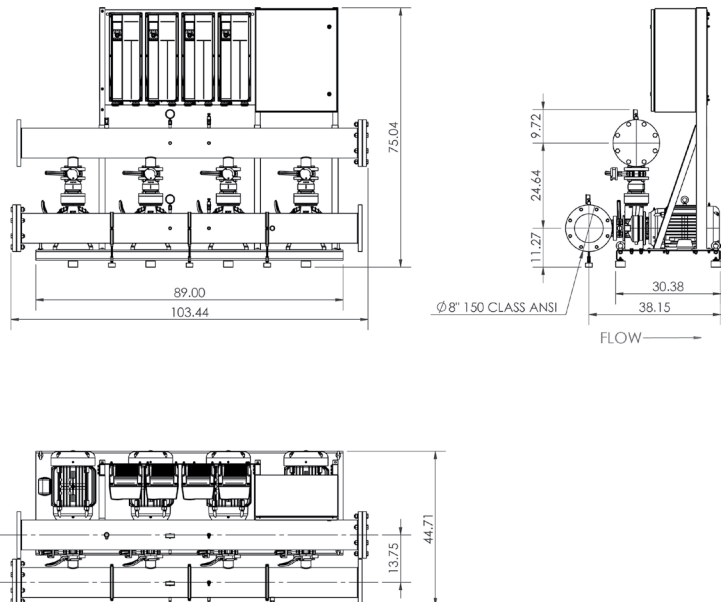
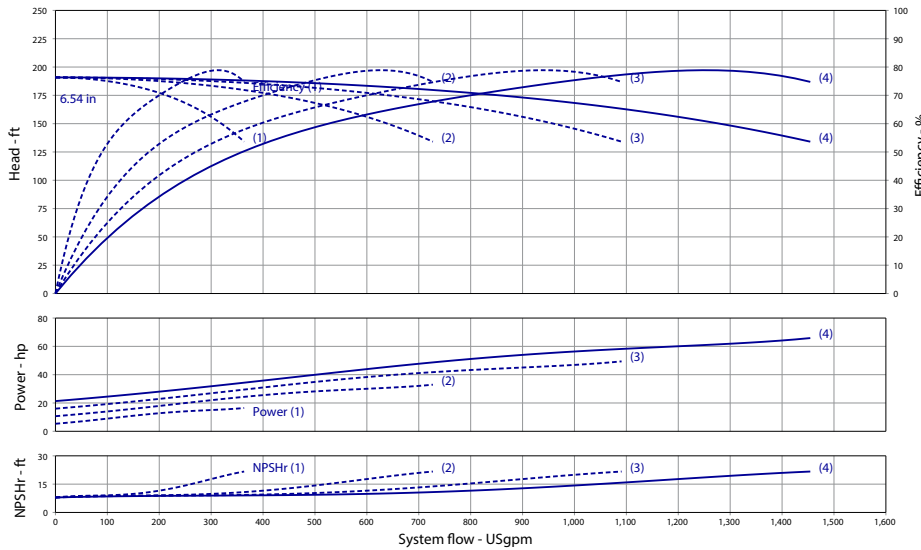

Product Info

Brand	Wilo
Product Description	WiBooster 4/327/A1/315/TEFC

Construction Materials

Pump Volute	304 Stainless Steel
Impeller	304 Stainless Steel
Shaft	304 Stainless Steel
Elastomers	EPDM
Isolation Valves	Butterfly, SS Stem/Disc, EPDM Seal
Manifolds	304 Stainless Steel, ANSI-Flanged
Check Valves	Stainless Steel, Non-Slam, Plunger Type with EPDM Seal
Mechanical Seal	Type 21
Pressure Transducers	316 Stainless Steel
Pressure Gauges	304/316 Stainless Steel
System Base	Plated Steel
Vibration Isolators	Neoprene, Height-Adjustable

Motor Data

Motor Power Supply	3-208-230V
Enclosure	TEFC
Efficiency	NEMA Premium
Horsepower/Pump	20
Enclosure Material	Rolled Steel/Cast Iron
Motor Protection Class	IP54
Insulation Class	F

Hydraulic Data

Max Operating Pressure	150 PSI
Max Inlet Pressure	75 PSI
Min. Fluid Temp.	40°F
Max Fluid Temp.	140°F
Min. Ambient Temp	32°F
Max. Ambient Temp	104°F

Panel Info

Power Supply	3-208-230
Enclosure	NEMA 12 (3R Available on Request)
Standard	Meets UL 508A
VFD's	Danfoss FC-101/FC-202

PLC Info

User Interface	7" Color Touchscreen
Display Resolution	800 x 480 Pixels
Supply Voltage	24VDC
Max Current	320mA @24V
Analog Inputs/Outputs	9/2
Digital Inputs/Outputs	18/17
Communications	ModBUS Standard (BacNET, LONWorks Optional)
Ethernet Port	RJ45 (10/100Mbps)
Additional Ports	USB 2.0, Micro-SD



Triplex Phase and Voltage	Full Flow Connection (in)			Half Flow Connection (in)		
	3-208-230V	3-460V	3-575V	3-575V	3-460	3-575
Panel Dimensions (HxWxD)	24x24x8	30x30x10	24x24x8	24x24x8	30x30x10	24x24x8
Full Load Amps (Per Pump)	47	23.5	19	47	23.5	19
Panel Weight (lbs)	120	209.7	96	120	209.7	96
External VFD Weight (ea - lbs)	60	X	50	60	X	50
Pump Weight (ea - lbs)	260	260	260	260	260	260
System Weight (lbs)	2615	2375	2555	2470	2225	2410

Wilo-WiBooster

		Project:					
		Engineer:					
		Contractor:					
		Submitted By:			Date:		
		Approved By:			Date:		
Tag #	Model #	Flow	Head	HP/Pump	Cycle	Phase	Voltage
	WiBooster 4/327/A1/TEFC			20	60Hz		

Article Number: 3311268

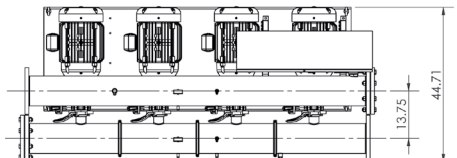
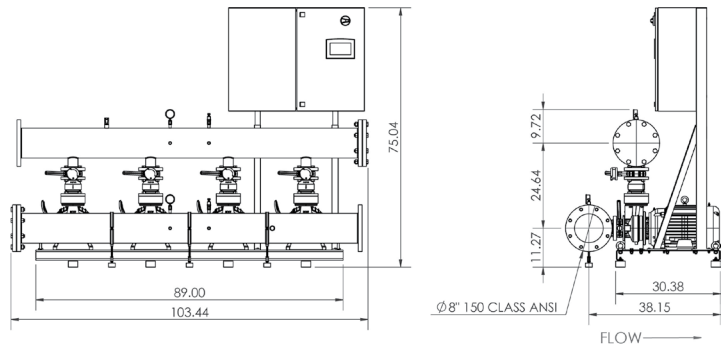
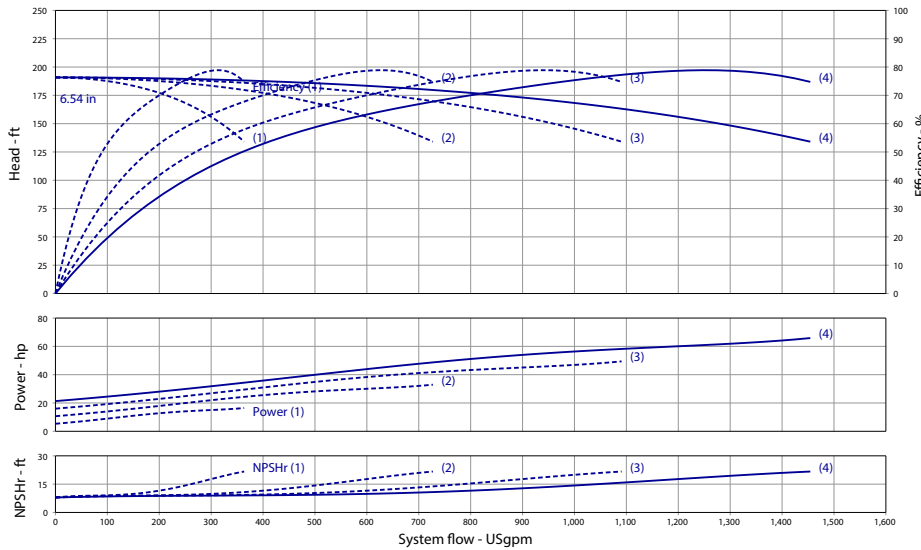

Product Info

Brand	Wilo
Product Description	WiBooster 4/327/A1/315/TEFC

Construction Materials

Pump Volute	304 Stainless Steel
Impeller	304 Stainless Steel
Shaft	304 Stainless Steel
Elastomers	EPDM
Isolation Valves	Butterfly, SS Stem/Disc, EPDM Seal
Manifolds	304 Stainless Steel, ANSI-Flanged
Check Valves	Stainless Steel, Non-Slam, Plunger Type with EPDM Seal
Mechanical Seal	Type 21
Pressure Transducers	316 Stainless Steel
Pressure Gauges	304/316 Stainless Steel
System Base	Plated Steel
Vibration Isolators	Neoprene, Height-Adjustable

Motor Data

Motor Power Supply	3-460V
Enclosure	TEFC
Efficiency	NEMA Premium
Horsepower/Pump	20
Enclosure Material	Rolled Steel/Cast Iron
Motor Protection Class	IP54
Insulation Class	F

Hydraulic Data

Max Operating Pressure	150 PSI
Max Inlet Pressure	75 PSI
Min. Fluid Temp.	40°F
Max Fluid Temp.	140°F
Min. Ambient Temp.	32°F
Max. Ambient Temp.	104°F

Panel Info

Power Supply	3-460
Enclosure	NEMA 12 (3R Available on Request)
Standard	Meets UL 508A
VFD's	Danfoss FC-101/FC-202

PLC Info

User Interface	7" Color Touchscreen
Display Resolution	800 x 480 Pixels
Supply Voltage	24VDC
Max Current	320mA @24V
Analog Inputs/Outputs	9/2
Digital Inputs/Outputs	18/17
Communications	ModBUS Standard (BacNET, LONWorks Optional)
Ethernet Port	RJ45 (10/100Mbps)
Additional Ports	USB 2.0, Micro-SD



Triplex Phase and Voltage	Full Flow Connection (in)			Half Flow Connection (in)		
	3~208-230V	3~460V	3~575V	3~575V	3~460	3~575
Panel Dimensions (HxWxD)	24x24x8	30x30x10	24x24x8	24x24x8	30x30x10	24x24x8
Full Load Amps (Per Pump)	47	23.5	19	47	23.5	19
Panel Weight (lbs)	120	209.7	96	120	209.7	96
External VFD Weight (ea - lbs)	60	X	50	60	X	50
Pump Weight (ea - lbs)	260	260	260	260	260	260
System Weight (lbs)	2615	2375	2555	2470	2225	2410

Wilo-WiBooster

		Project:					
		Engineer:					
		Contractor:					
		Submitted By:			Date:		
		Approved By:			Date:		
Tag #	Model #	Flow	Head	HP/Pump	Cycle	Phase	Voltage
	WiBooster 4/327/A1/TEFC			20	60Hz		

Article Number: 3311286

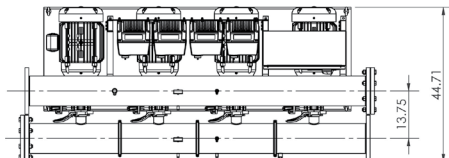
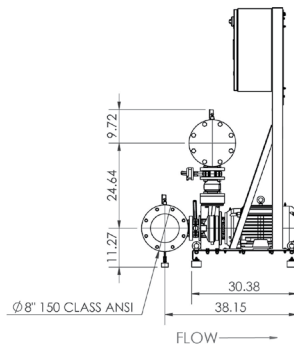
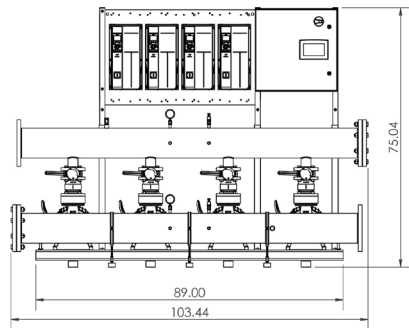
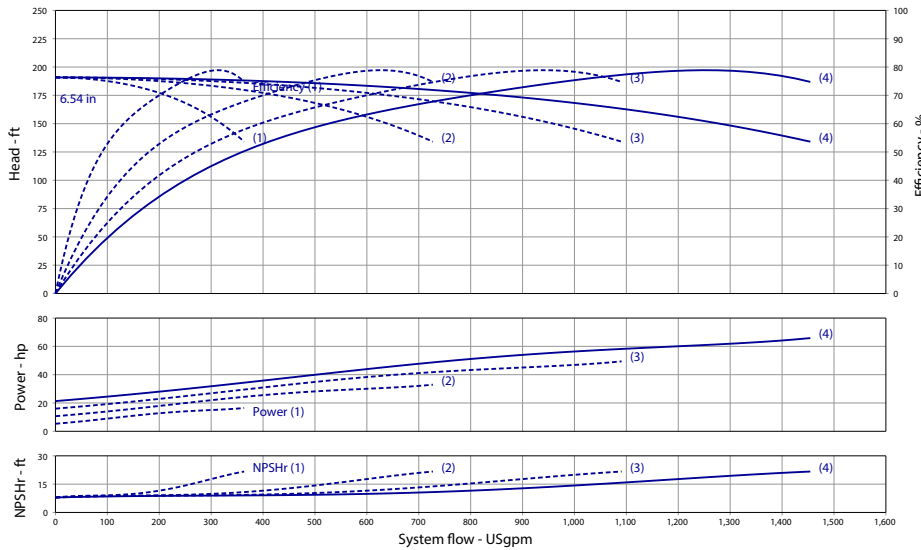

Product Info

Brand	Wilo
Product Description	WiBooster 4/327/A1/315/TEFC

Construction Materials

Pump Volute	304 Stainless Steel
Impeller	304 Stainless Steel
Shaft	304 Stainless Steel
Elastomers	EPDM
Isolation Valves	Butterfly, SS Stem/Disc, EPDM Seal
Manifolds	304 Stainless Steel, ANSI-Flanged
Check Valves	Stainless Steel, Non-Slam, Plunger Type with EPDM Seal
Mechanical Seal	Type 21
Pressure Transducers	316 Stainless Steel
Pressure Gauges	304/316 Stainless Steel
System Base	Plated Steel
Vibration Isolators	Neoprene, Height-Adjustable

Motor Data

Motor Power Supply	3-575V
Enclosure	TEFC
Efficiency	NEMA Premium
Horsepower/Pump	20
Enclosure Material	Rolled Steel/Cast Iron
Motor Protection Class	IP54
Insulation Class	F

Hydraulic Data

Max Operating Pressure	150 PSI
Max Inlet Pressure	75 PSI
Min. Fluid Temp.	40°F
Max Fluid Temp.	140°F
Min. Ambient Temp	32°F
Max. Ambient Temp	104°F

Panel Info

Power Supply	3-575
Enclosure	NEMA 12 (3R Available on Request)
Standard	Meets UL 508A
VFD's	Danfoss FC-101/FC-202

PLC Info

User Interface	7" Color Touchscreen
Display Resolution	800 x 480 Pixels
Supply Voltage	24VDC
Max Current	320mA @24V
Analog Inputs/Outputs	9/2
Digital Inputs/Outputs	18/17
Communications	ModBUS Standard (BacNET, LONWorks Optional)
Ethernet Port	RJ45 (10/100Mbps)
Additional Ports	USB 2.0, Micro-SD



Triplex Phase and Voltage	Full Flow Connection (in)			Half Flow Connection (in)		
	3~208-230V	3~460V	3~575V	3~575V	3~460	3~575
Panel Dimensions (HxWxD)	24x24x8	30x30x10	24x24x8	24x24x8	30x30x10	24x24x8
Full Load Amps (Per Pump)	47	23.5	19	47	23.5	19
Panel Weight (lbs)	120	209.7	96	120	209.7	96
External VFD Weight (ea - lbs)	60	X	50	60	X	50
Pump Weight (ea - lbs)	260	260	260	260	260	260
System Weight (lbs)	2615	2375	2555	2470	2225	2410

Wilo-WiBooster

		Project:					
		Engineer:					
		Contractor:					
		Submitted By:			Date:		
		Approved By:			Date:		
Tag #	Model #	Flow	Head	HP/Pump	Cycle	Phase	Voltage
	WiBooster 4/327/A2/TEFC			20	60Hz		

Article Number: 3313247

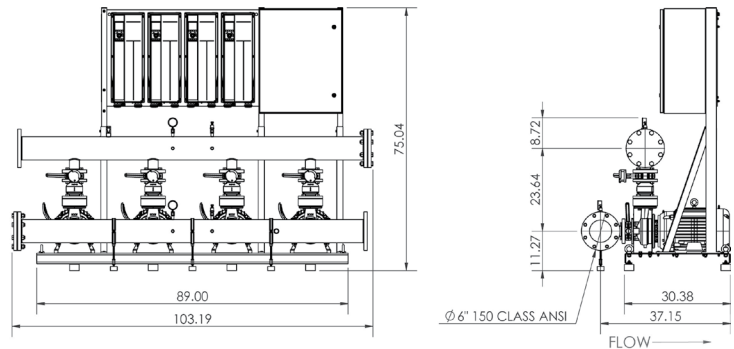
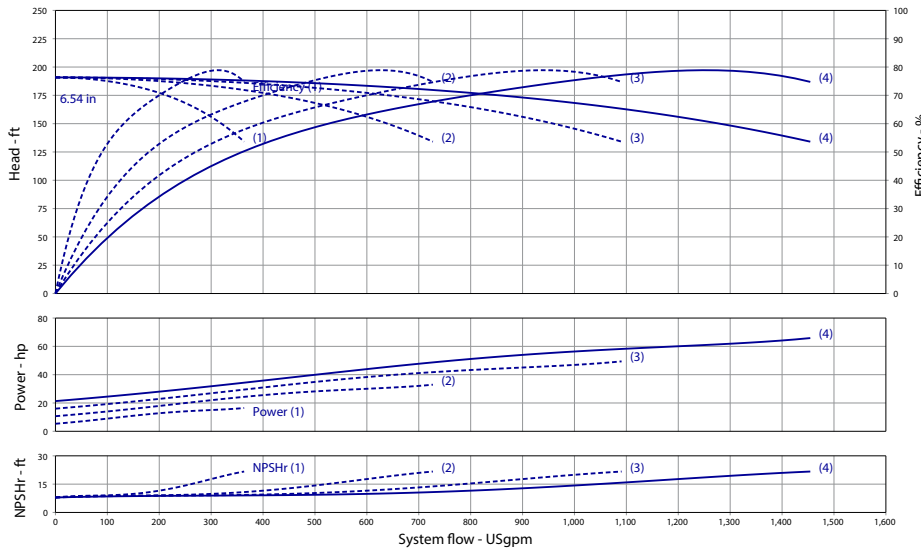

Product Info

Brand	Wilo
Product Description	WiBooster 4/327/A2/315/TEFC

Construction Materials

Pump Volute	304 Stainless Steel
Impeller	304 Stainless Steel
Shaft	304 Stainless Steel
Elastomers	EPDM
Isolation Valves	Butterfly, SS Stem/Disc, EPDM Seal
Manifolds	304 Stainless Steel, ANSI-Flanged
Check Valves	Stainless Steel, Non-Slam, Plunger Type with EPDM Seal
Mechanical Seal	Type 21
Pressure Transducers	316 Stainless Steel
Pressure Gauges	304/316 Stainless Steel
System Base	Plated Steel
Vibration Isolators	Neoprene, Height-Adjustable

Motor Data

Motor Power Supply	3~208-230V
Enclosure	TEFC
Efficiency	NEMA Premium
Horsepower/Pump	20
Enclosure Material	Rolled Steel/Cast Iron
Motor Protection Class	IP54
Insulation Class	F

Hydraulic Data

Max Operating Pressure	150 PSI
Max Inlet Pressure	75 PSI
Min. Fluid Temp.	40°F
Max Fluid Temp.	140°F
Min. Ambient Temp.	32°F
Max. Ambient Temp.	104°F

Panel Info

Power Supply	3~208-230
Enclosure	NEMA 12 (3R Available on Request)
Standard	Meets UL 508A
VFD's	Danfoss FC-101/FC-202

PLC Info

User Interface	7" Color Touchscreen
Display Resolution	800 x 480 Pixels
Supply Voltage	24VDC
Max Current	320mA @24V
Analog Inputs/Outputs	9/2
Digital Inputs/Outputs	18/17
Communications	ModBUS Standard (BacNET, LONWorks Optional)
Ethernet Port	RJ45 (10/100Mbps)
Additional Ports	USB 2.0, Micro-SD



Triplex Phase and Voltage	Full Flow Connection (in)			Half Flow Connection (in)		
	3~208-230V	3~460V	3~575V	3~575V	3~460	3~575
Panel Dimensions (HxWxD)	24x24x8	30x30x10	24x24x8	24x24x8	30x30x10	24x24x8
Full Load Amps (Per Pump)	47	23.5	19	47	23.5	19
Panel Weight (lbs)	120	209.7	96	120	209.7	96
External VFD Weight (ea - lbs)	60	X	50	60	X	50
Pump Weight (ea - lbs)	260	260	260	260	260	260
System Weight (lbs)	2615	2375	2555	2470	2225	2410

Wilo-WiBooster

		Project:					
		Engineer:					
		Contractor:					
		Submitted By:			Date:		
		Approved By:			Date:		
Tag #	Model #	Flow	Head	HP/Pump	Cycle	Phase	Voltage
	WiBooster 4/327/A2/TEFC			20	60Hz		

Article Number: 3313265

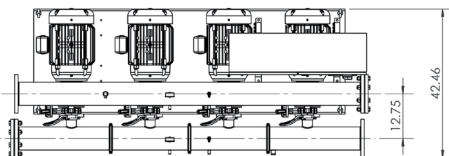
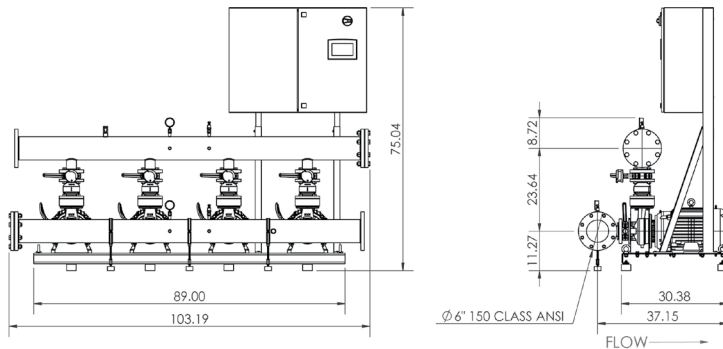
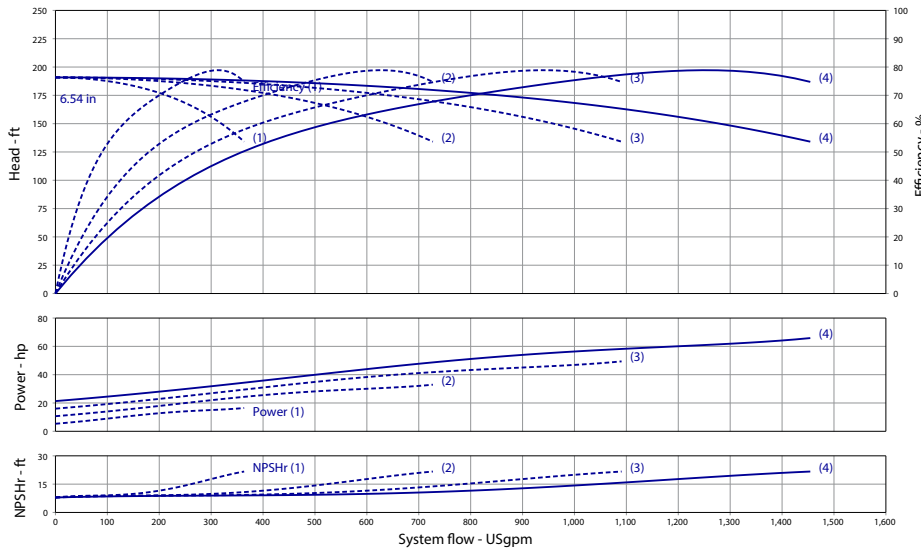

Product Info

Brand	Wilo
Product Description	WiBooster 4/327/A2/315/TEFC

Construction Materials

Pump Volute	304 Stainless Steel
Impeller	304 Stainless Steel
Shaft	304 Stainless Steel
Elastomers	EPDM
Isolation Valves	Butterfly, SS Stem/Disc, EPDM Seal
Manifolds	304 Stainless Steel, ANSI-Flanged
Check Valves	Stainless Steel, Non-Slam, Plunger Type with EPDM Seal
Mechanical Seal	Type 21
Pressure Transducers	316 Stainless Steel
Pressure Gauges	304/316 Stainless Steel
System Base	Plated Steel
Vibration Isolators	Neoprene, Height-Adjustable

Motor Data

Motor Power Supply	3-460V
Enclosure	TEFC
Efficiency	NEMA Premium
Horsepower/Pump	20
Enclosure Material	Rolled Steel/Cast Iron
Motor Protection Class	IP54
Insulation Class	F

Hydraulic Data

Max Operating Pressure	150 PSI
Max Inlet Pressure	75 PSI
Min. Fluid Temp.	40°F
Max Fluid Temp.	140°F
Min. Ambient Temp.	32°F
Max. Ambient Temp.	104°F

Panel Info

Power Supply	3-460
Enclosure	NEMA 12 (3R Available on Request)
Standard	Meets UL 508A
VFD's	Danfoss FC-101/FC-202

PLC Info

User Interface	7" Color Touchscreen
Display Resolution	800 x 480 Pixels
Supply Voltage	24VDC
Max Current	320mA @24V
Analog Inputs/Outputs	9/2
Digital Inputs/Outputs	18/17
Communications	ModBUS Standard (BacNET, LONWorks Optional)
Ethernet Port	RJ45 (10/100Mbps)
Additional Ports	USB 2.0, Micro-SD



Triplex Phase and Voltage	Full Flow Connection (in)			Half Flow Connection (in)		
	3~208-230V	3~460V	3~575V	3~575V	3~460	3~575
Panel Dimensions (HxWxD)	24x24x8	30x30x10	24x24x8	24x24x8	30x30x10	24x24x8
Full Load Amps (Per Pump)	47	23.5	19	47	23.5	19
Panel Weight (lbs)	120	209.7	96	120	209.7	96
External VFD Weight (ea - lbs)	60	X	50	60	X	50
Pump Weight (ea - lbs)	260	260	260	260	260	260
System Weight (lbs)	2615	2375	2555	2470	2225	2410

Wilo-WiBooster

		Project:					
		Engineer:					
		Contractor:					
		Submitted By:			Date:		
		Approved By:			Date:		
Tag #	Model #	Flow	Head	HP/Pump	Cycle	Phase	Voltage
	WiBooster 4/328/B2/TEFC			20	60Hz		

Article Number: 3313283

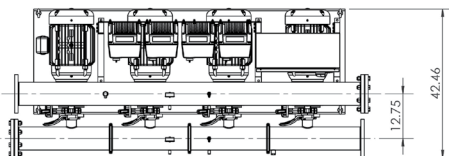
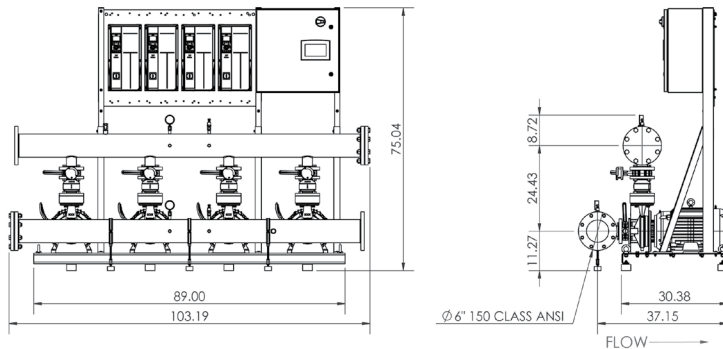
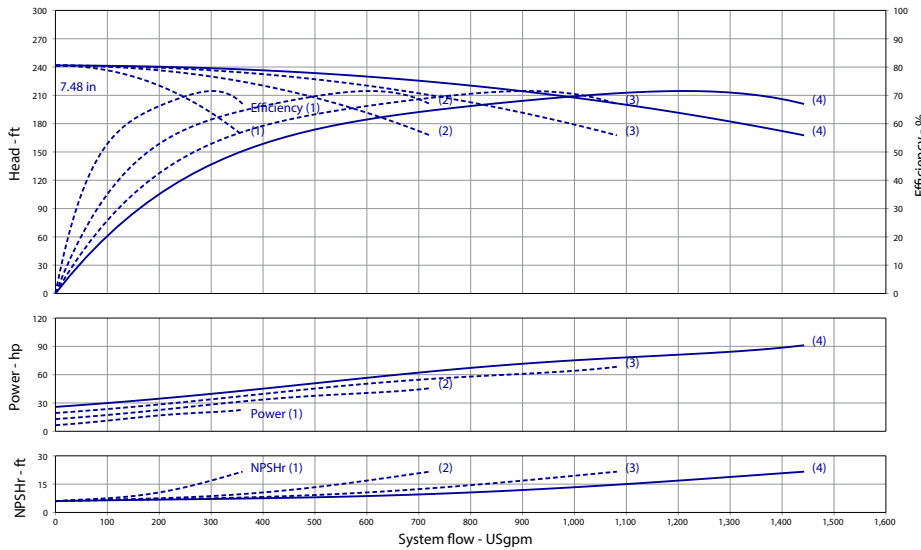

Product Info

Brand	Wilo
Product Description	WiBooster 4/328/B2/300/TEFC

Construction Materials

Pump Volute	304 Stainless Steel
Impeller	304 Stainless Steel
Shaft	304 Stainless Steel
Elastomers	EPDM
Isolation Valves	Butterfly, SS Stem/Disc, EPDM Seal
Manifolds	304 Stainless Steel, ANSI-Flanged
Check Valves	Stainless Steel, Non-Slam, Plunger Type with EPDM Seal
Mechanical Seal	Type 21
Pressure Transducers	316 Stainless Steel
Pressure Gauges	304/316 Stainless Steel
System Base	Plated Steel
Vibration Isolators	Neoprene, Height-Adjustable

Motor Data

Motor Power Supply	3-575V
Enclosure	TEFC
Efficiency	NEMA Premium
Horsepower/Pump	20
Enclosure Material	Rolled Steel/Cast Iron
Motor Protection Class	IP54
Insulation Class	F

Hydraulic Data

Max Operating Pressure	150 PSI
Max Inlet Pressure	75 PSI
Min. Fluid Temp.	40°F
Max Fluid Temp.	140°F
Min. Ambient Temp	32°F
Max. Ambient Temp	104°F

Panel Info

Power Supply	3-575
Enclosure	NEMA 12 (3R Available on Request)
Standard	Meets UL 508A
VFD's	Danfoss FC-101/FC-202

PLC Info

User Interface	7" Color Touchscreen
Display Resolution	800 x 480 Pixels
Supply Voltage	24VDC
Max Current	320mA @24V
Analog Inputs/Outputs	9/2
Digital Inputs/Outputs	18/17
Communications	ModBUS Standard (BacNET, LONWorks Optional)
Ethernet Port	RJ45 (10/100Mbps)
Additional Ports	USB 2.0, Micro-SD



Triplex Phase and Voltage	Full Flow Connection (in)			Half Flow Connection (in)		
	3~208-230V	3~460V	3~575V	3~575V	3~460	3~575
Panel Dimensions (HxWxD)	24x24x8	30x30x10	24x24x8	24x24x8	30x30x10	24x24x8
Full Load Amps (Per Pump)	47	23.5	19	47	23.5	19
Panel Weight (lbs)	120	209.7	96	120	209.7	96
External VFD Weight (ea - lbs)	60	X	50	60	X	50
Pump Weight (ea - lbs)	270	270	270	270	270	270
System Weight (lbs)	2650	2410	2590	2505	2265	2445