

Wilo-WiBooster

		Project:					
		Engineer:					
		Contractor:					
		Submitted By:			Date:		
		Approved By:			Date:		
Tag #	Model #	Flow	Head	HP/Pump	Cycle	Phase	Voltage
	WiBooster 4/326/A			10	60Hz		

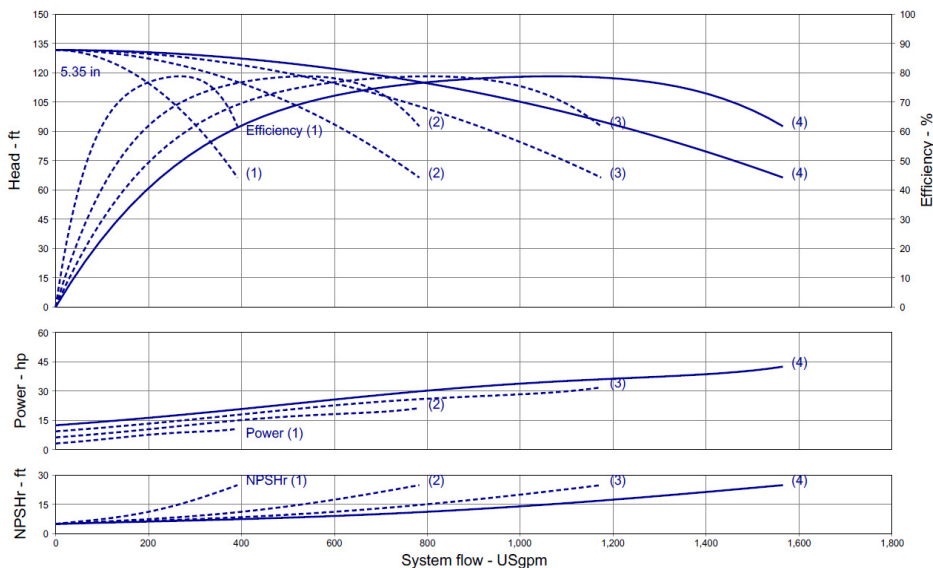

Product Info

Brand	Wilo
Product Description	WiBooster 4/326/A

Construction Materials

Pump Volute	304 Stainless Steel
Impeller	304 Stainless Steel
Shaft	304 Stainless Steel
Elastomers	EPDM
Isolation Valves	Butterfly, SS Stem/Disc, EPDM Seal
Manifolds	304 Stainless Steel, ANSI-Flanged
Check Valves	Stainless Steel, Non-Slam, Plunger Type with EPDM Seal
Mechanical Seal	Type 21
Pressure Transducers	316 Stainless Steel
Pressure Gauges	304/316 Stainless Steel
System Base	Plated Steel
Vibration Isolators	Neoprene, Height-Adjustable

Motor Data

Motor Power Supply	3~208-230/460/575V
Enclosure	ODP/TEFC
Efficiency	NEMA Premium
Horsepower/Pump	10
Enclosure Material	Rolled Steel/Cast Iron
Motor Protection Class	IP54
Insulation Class	F

Hydraulic Data

Max Operating Pressure	150 PSI
Max Inlet Pressure	75 PSI
Min. Fluid Temp.	40°F
Max Fluid Temp.	140°F
Min. Ambient Temp	32°F
Max. Ambient Temp	104°F

Panel Info

Power Supply	1~230, 3~208-230/460/575
Enclosure	NEMA 12 (3R Available on Request)
Standard	Meets UL 508A
VFD's	Danfoss FC-51 /FC-101

PLC Info

User Interface	7" Color Touchscreen
Display Resolution	800 x 480 Pixels
Supply Voltage	24VDC
Max Current	320mA @24V
Analog Inputs/Outputs	9/2
Digital Inputs/Outputs	18/17
Communications	ModBUS Standard (BacNET, LONWorks Optional)
Ethernet Port	RJ45 (10/100Mbps)
Additional Ports	USB 2.0, Micro-SD

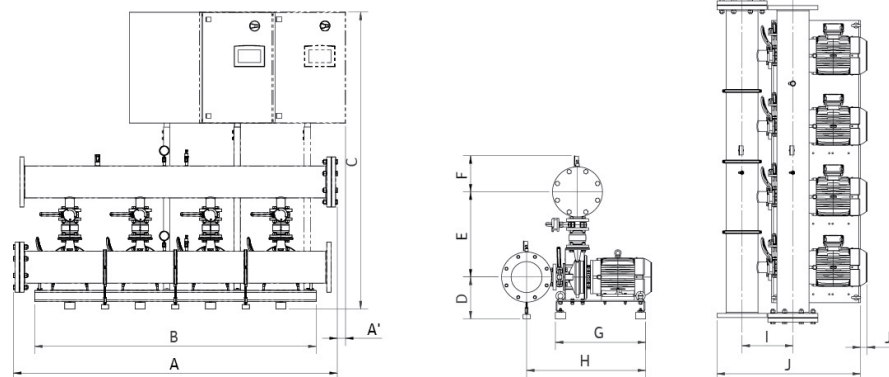

Dimensions

System Connection (150#)	Full Flow Connection (in)			Half Flow Connection (in)				
	1-3-230	3~208-230	3~460	3~575	1-3-230	3~208-230	3~460	3~575
A	x	87.4	87.4	87.4	x	87.2	87.2	87.2
A ₁	x	2.2	x	x	x	2.3	x	x
B	x	76	76	76	x	76	76	76
C	x	75	75	75	x	75	75	75
D	x	10.2	10.2	10.2	x	10.2	10.2	10.2
E	x	21.4	21.4	21.4	x	20.4	20.4	20.4
F	x	9.7	9.7	11	x	8.7	8.7	10
G	x	24.4	24.4	24.4	x	24.4	24.4	24.4
H	x	32.1	32.1	32.1	x	31.1	31.1	31.1
I	x	13.7	13.7	13.7	x	12.7	12.7	12.7
J	x	38.7	38.7	38.7	x	36.4	36.4	36.4
J ₁	x	2	2	2	x	2	2	2
Panel Dimensions (HxWxD)	x	30x39x12	30X30X10	30X30X10	x	30x39x12	30X30X10	30X30X10
Full Load Amps (per pump)	x	26.4-24.0	12.0	9.5	x	26.4-24.0	12.0	9.5
Panel Weight (lbs)	x	209.7	139	190	x	209.7	139	190
Pump Weight (ea - lbs)	x	201	201	201	x	201	201	201
System Weight (lbs)	x	1845	1770	1825	x	1730	1655	1710

Approval Stamp